



THIS IS PERCUSSION

CATALOG 2004



CATALOG 2004



THIS IS PERCUSSION



meinpercussion.com



**It's played from the heart.
It's played from the soul.
The real inner man.**

WHAT IS IT ALL ABOUT?

Even before birth, every human experiences it. Peacefully resting in the womb we feel it, 24 hours a day - 7 days a week for 9 months - mother's heartbeat. This inimitable phenomenon guides us through the seasons of life: Our heartbeat - breathing - seconds, minutes, hours, days, years - sunrise, sunset - winter, spring, summer, fall.

From our first breath to our last. It's about **RHYTHM!**

Human beings, regardless of their age, gender, cultural belonging, or historical background, consider rhythm as an elementary need. They have the urge to express rhythm in order to reflect and enhance their current spirit. Early civilizations discovered the power of rhythm by simply beating on trunks of trees or using simple drum-like instruments.

In the course of centuries, every civilization developed their own specific instruments reflecting various cultural imprints and applications. Early drums were used for communication purposes, tribal rituals and other cultural ceremonies.

In today's world however, there is a large variety of different rhythm instruments available, suitable for all different skills and types of playing or fields of applications.

All of these different kinds of human rhythmic expressions can be summed up in one word: "PERCUSSION"

Playing percussion effects our feelings directly. It helps us to find our inner peace.

It can relax- or thrill us.

And last but not least, playing percussion is always great fun!

MEINL - THIS IS PERCUSSION!





MEINL GLOBAL HEADQUARTER
GUTENSTETTEN, GERMANY

It is our mission to offer everybody, regardless of being a pro or first time player, the right instrument which matches her or his specific needs. As diverse as those players are, just as diverse are their individual demands.

MEINL
HEADLINER® RANGE

MEINL
PROFESSIONAL RANGE

NINO® PERCUSSION
BY MEINL

MEINL THIS IS:

VARIETY

Over the last 25 years we have created a specific portfolio of ranges to match the variety of our customers. Today we are proud to offer a wide assortment of high quality percussion instruments for players all around the world regardless of age, playing skills, or economic background. A large variety of colours, a well thought out assortment and trend setting ideas is what MEINL Percussion stands for.

COMPETENCE

As a modern and progressive company, MEINL has never been content with the status quo! By talking and listening to the people who play, we have developed many new and improved percussion instruments. Original MEINL innovations like the Free Ride System for Bongos (patented), the Floatune® Tuning System for Timbales and Djembes (patented), the revolutionary STEELY II Conga and Djembe Stands (patented), or the Professional Conga and Bongo Stands (patented) prove our leading position in Research and Development work and set the standard in the percussion world.



MEINL GLOBAL HEADQUARTER
Am Bahnhof 2
91468 Gutenstetten
GERMANY

MEINL USA L.C.
3354 Ambrose Avenue
Nashville, TN 37207
USA

RESPONSIBILITY

Our perception of what it means to be a global player tells us not to measure success in sales only; it is also the way how we achieve it! As a family owned and managed company, we conduct business with integrity, respecting our employees, customers, artists, and the environment around us. Therefore we strictly observe the CITES-regulations set forth in the "Convention on International Trade in Endangered Species of Wild Fauna and Flora" and only use wood from environmentally controlled forests or industrial wood plantations.

QUALITY

Since our formation, our main objective has been to offer percussion instruments which comply with the highest quality levels regarding manufacturing and materials used. Only by committing to the highest standards can we guarantee top quality instruments, the maximum of playing comfort, the best possible sounds, and therefore long lasting customer fulfilment.

As one of today's worldwide leading percussion manufacturer with the highest quality standards, a large variety of instruments available, innovative ideas, and a steadily growing roster of professional artists, we can confidently affirm:

MEINL - THIS IS PERCUSSION!





HEADLINER® RANGE

MY CHOICE

MEINL's Headliner® Range of Percussion features great quality, sound and workmanship at an affordable price.

It offers first time as well as advanced players percussion instruments which meet the highest standards.

Selected materials, accurate converting and stability guarantee a long lasting enjoyment of the MEINL Headliner® Range.

CHOICE
MY CHOICE
MY CHOICE



HEADLINER® RANGE CONGA SETS

Get started with the MEINL Headliner® Range Conga Sets. They offer outstanding quality and great value in the budget price range, yet are equipped with many features known from professional instruments. Ideal for the student and hobbyist.



Ray Yslas, USA (Christina Aguilera):
 "The MEINL Headliner Range Congas are by far the best in this price range. I wish I would have had them when I started to play."

HC555 WOOD CONGAS

- Sizes** 10" & 11" Conga Set
28" tall
- Material** Rubber Wood (*Hevea brasiliensis* Muell.-Arg.)
- Features** Hand selected buffalo heads
8 mm strong tuning lugs
Original MEINL style tuning brackets
2 mm rounded rims
Black powder coated hardware
- Includes** Height adjustable basket stands with quick set up system
Tuning key
- Colours** BSB = Blue Burst
NT = Natural
VSB = Vintage Sunburst
WR = Wine Red
- Finish** Hi Gloss



Height adjustable
 U-shaped notches allow quick set up and breakdown

HC555NT



HC512 WOOD CONGAS

- Sizes** 11" & 12" Conga Set
28" tall
- Material** Rubber Wood (*Hevea brasiliensis* Muell.-Arg.)
- Features** Hand selected buffalo heads
8 mm strong tuning lugs
Original MEINL style tuning brackets
2 mm rounded rims
Black powder coated hardware
- Includes** Height adjustable basket stands with quick set up system
Tuning key
- Colours** BSB = Blue Burst
NT = Natural
VSB = Vintage Sunburst
WR = Wine Red
- Finish** Hi Gloss



HC512WR



HC888 WOOD CONGAS

- Sizes** 10" & 11" Conga Set
28" tall
- Material** Rubber Wood (*Hevea brasiliensis* Muell.-Arg.)
- Features** Hand selected buffalo heads
8 mm strong tuning lugs
Original MEINL style tuning brackets
2 mm rounded rims
Black powder coated hardware
- Includes** Height adjustable double braced tripod stand
Tuning key
- Colours** BSB = Blue Burst
NT = Natural
VSB = Vintage Sunburst
WR = Wine Red
- Finish** Hi Gloss



Black powder coated 2 mm rounded rims
 Hand selected buffalo heads

HC888VSB



HC812 WOOD CONGAS

- Sizes** 11" & 12" Conga Set
28" tall
- Material** Rubber Wood (*Hevea brasiliensis* Muell.-Arg.)
- Features** Hand selected buffalo heads
8 mm strong tuning lugs
Original MEINL style tuning brackets
2 mm rounded rims
Black powder coated hardware
- Includes** Height adjustable double braced tripod stand
Tuning key
- Colours** BSB = Blue Burst
NT = Natural
VSB = Vintage Sunburst
WR = Wine Red
- Finish** Hi Gloss



HC812BSB





WOOD BONGOS

MEINL Headliner® Range Bongos are perfect for the student or hobbyist who is looking for a high quality instrument right from the beginning.

- Sizes** 6 3/4" Macho & 8" Hembra
Material Rubber Wood (*Hevea brasiliensis* Muell.-Arg.)
Features Hand selected buffalo heads
 8 mm strong tuning lugs
 2 mm rounded rims
 Black powder coated hardware
 Interior backing plates
Includes Tuning key
Colours BSB = Blue Burst
 NT = Natural
 VSB = Vintage Sunburst
 WR = Wine Red
Finish Hi Gloss



Interior backing plates add strength to construction



BONGO STAND

The MEINL Headliner® Range Bongo Stand ensures a stable and reliable placing of your bongo. A stress-free and quick setup solution at an affordable price. Fits other bongo brands as well.

- Material** Chrome plated steel
Features Height adjustable
 Double braced tripod stand
 Fits other brands
 Memory lock
Includes Wrench



A stable metal clamp holds the entire unit in place



TIMBALES

The MEINL Headliner® Range Timbales come in 13" and 14" sizes, are made from chrome plated steel and come with a heavy duty-, height adjustable tilting stand. They provide the classic timbale sound and are the perfect introduction to the joy and passion of timbale playing at an affordable price.

- Sizes** 13" & 14"
Material Chrome plated steel
Includes Height adjustable tilting double braced tripod stand
 Tuning key
 Wrench
 Cowbell holder



WOOD DJEMBES

If you are looking for an affordable djembe for drum circles or spontaneous jam sessions, don't look any further! The MEINL Headliner® Range Djembes have it all! Equipped with hand selected goat heads they produce the classic djembe sounds reaching from fat basses to rich open tones and cutting slaps.

- Size** 12"
 23 1/2" tall
Material Rubber Wood (*Hevea brasiliensis* Muell.-Arg.)
Features 8 mm strong tuning lugs
 2 mm rounded rims
 Original MEINL style tuning brackets
 Black powder coated hardware
 Hand selected goat heads
Includes Tuning key
Colours BSB = Blue Burst
 NT = Natural
 VSB = Vintage Sunburst
 WR = Wine Red
Finish Hi Gloss



WOOD CONGUITAS

The MEINL Headliner® Range Conguitas are a perfect addition to any percussion set up. They are made from high quality materials and produce a cutting and strong percussive tone which complements the congas in a harmonically supportive sound spectrum. A heavy duty stand which can be tilted holds the drums securely.

- Sizes** 8" & 9"
Material Rubber Wood (*Hevea brasiliensis* Muell.-Arg.)
Features 8 mm strong tuning lugs
 Original MEINL style tuning brackets
 Traditional rim
 Black powder coated hardware
 Hand selected buffalo heads
Includes Height adjustable tilting double braced tripod stand
 Tuning key
 Wrench
Colour NT = Natural
Finish Hi Gloss





HEADLINER® RANGE DANCING DRUMS

The MEINL Headliner® Range Dancing Drums are the perfect instruments for educational or street percussion. They are made from high quality materials and produce great sounds. A great gift idea as well.

FIBERGLASS DANCING DJEMBES

- Size** 12"
22 3/4" tall
- Material** Premium fiberglass
- Features** 7 mm strong tuning lugs
2.2 mm rounded rim
Black powder coated hardware
- Includes** Nylon strap
Tuning key
- Colours** BK = Black
R = Red



FIBERGLASS FAMILY DRUMS

- Sizes** 8"
13 1/2" / 11 1/4" / 9 3/4" tall
- Material** Premium fiberglass
- Features** 8 mm strong tuning lugs
Traditional rim
Black powder coated hardware
- Includes** Nylon strap
Tuning key



FIBERGLASS DANCING CONGAS

- Size** 8 1/2"
24" tall
- Material** Premium fiberglass
- Features** 7 mm strong tuning lugs
1.6 mm rounded rim
Black powder coated hardware
- Includes** Nylon strap
Tuning key
- Colours** BK = Black
R = Red



FIBERGLASS MINI DANCING DJEMBES

- Size** 8"
14 1/3" tall
- Material** Premium fiberglass
- Features** Traditional rim
Black powder coated hardware
Floatune® Tuning System
- Includes** Nylon strap
Tuning key
- Colours** B = Blue
G = Green
Y = Yellow



CHIMES

The MEINL Headliner® Range Chimes are a great and affordable addition to any percussion set up! They are made from high quality materials and produce a full and warm chime sound.

- Size** 27 bars
- Material** Silver anodized aluminum alloy
- Colour** R = Red



HCH1R

COWBELLS

Made from black powder coated steel, the MEINL Headliner® Range Cowbells produce a cutting and sharp sound. Whether used in a percussion set up or in a drum set configuration, they always add a special flavor to your groove.

- Sizes** 5"
8"
- Material** Black powder coated steel



HC04BK

HC02BK

JINGLE STICKS

The MEINL Headliner® Range Jingle Sticks are a nice and affordable alternative to a tambourine. It can be used in drum circles, gatherings, street percussion and educational fields. Nice sound effects are also achieved when used as a stick on a drum.

- Material** Jingles: Nickelsilver plated steel
Frame: ABS
- Colours** BK = Black
R = Red



HJS1R

HJS1BK

BASKET STANDS (patent pending)

The MEINL Headliner® Range Basket Stands for congas ensure a comfortable and stable placing of your congas. The innovative U-notch system allows a quick set-up and breakdown. It is height adjustable and suitable for other brands as well.

- Sizes** 10"
11"
12"
- Material** Black powder coated steel
- Features** Fully height adjustable
U-shaped notch for quick set up and breakdown
Twirled legs for more stability
Fits other brands



HSTAND

HDSTAND

DOUBLE STAND

The MEINL Headliner® Range Double Stand features a tripod stand with double braced legs and is height adjustable.

- Material** Steel
- Features** Height adjustable double braced tripod stand
Memory lock
- Includes** Wrench



NO COMPROMISES



PROFESSIONAL RANGE

NO COMPROMISES

MEINL's Professional Range of Percussion is designed for working musicians and professional players with the highest demands.

Only the finest quality materials are used to produce the best sounding and most functional percussion instruments.

MEINL's Research and Development Team, along with the expertise of top professional players, have raised the bar line with the MEINL Professional Range.

NO COMPROMISES



MEINL



MIPA AWARD FOR MEINL PROFESSIONAL SERIES CONGAS

The "Musikmesse International Press Award" is annually presented by 55 music magazines from all over the world who get together and vote the best products in certain categories. In 2002, the MEINL Professional Series Congas won the Mipa Award in the "best percussion product" category.



RUBBER WOOD (*Hevea brasiliensis* Muell.-Arg.)

Thailand is a logical manufacturing base for percussion instruments due to the fact that *Hevea brasiliensis*, which was indigenous to Brazil and later transported by way of England to Asia, has been commercially grown in Southeast Asia during the last century on plantation farms for the production of latex. The traditional plantation of rubber wood (*Hevea brasiliensis* Muell.-Arg.) meets all ecological requirements. In a natural evolution, new trees are planted and the older ones, which have ceased to provide latex, are harvested. In this way, plenty of raw material is available and the valuable rain forest eco-system is preserved. In addition to rubber wood (*Hevea brasiliensis* Muell.-Arg.), we also utilize American White Ash (*Fraxinus americana* L.) which also meets all the CITES-regulations set in the "Convention on International Trade in Endangered Species of Wild Fauna and Flora".



TRUE SKIN BUFFALO

MEINL True Skin Buffalo Heads are without a doubt the perfect choice for both wood and fiberglass congas due to their structure, thickness, and sonic characteristics. True Skin hides are selected by specialists. After the selection process, each skin is gently tanned using a special MEINL procedure and then mounted by hand to become a first class True Skin Head.



SSR

The MEINL Safe & Sound-Rim (SSR) for congas features a rounded profile to support a comfortable playing feel and prevents palm injuries.



TTR

The MEINL Traditional-Tuning-Rim (TTR) for congas represents the traditional "Cuban Style". It is narrowly placed around the shell and enhances the overall conga sound.



CONGA SAVER

The patented Conga Saver is truly a MEINL innovation. Available in 8 mm and 10 mm versions, they are placed over the conga lugs to prevent them from damaging and scratching the shell while the conga remains fully tuneable.



FLOATUNE® TUNING SYSTEM

The Floatune® Tuning System is an unique feature and truly another MEINL innovation. It is mounted without having to drill into the shells and allows them to vibrate freely.





MARATHON® CLASSIC SERIES

MARATHON® CLASSIC SERIES

The MEINL Marathon® Classic Series Congas set the standard in this price range by which other wood congas are judged. They combine professional features at a very attractive price price.

- Sizes** 11" Quinto, 11 3/4" Conga, 12 1/2" Tumba
30" tall
- Material** Two ply Rubber Wood (*Hevea brasiliensis* Muell.-Arg.)
- Features** True Skin Buffalo Heads
8 mm strong tuning lugs
2.6 mm rounded SSR-Rims
Black powder coated hardware
- Includes** Steely II Conga Stand (patented)
Accessory pouch
L-shaped tuning key
Tune Up Oil
- Colours** CN-M = Chest Nut
GSB-M = Gold Sunburst
SNT-M = Super Natural
Matt
- Finish** Matt



Luis Conte, USA (Phil Collins):
"The MEINL Marathon® Classic Congas have a very warm sound along with professional features. I've been using them on tour with Phil Collins for years."



Black powder coated
2.6 mm rounded SSR-
Rim



Metal spike attachment
on every rubber foot,
L-shaped legs (patented)



Height adjustable



U-shaped notches
allow quick set up and
breakdown (patent
pending)





MARATHON® EXCLUSIVE SERIES

The MEINL Marathon® Exclusive Series Wood Congas include many professional features. Ideal for the working percussionist who demands a great sound combined with quality and excellent craftsmanship.

- Sizes** 11" Quinto, 11 3/4" Conga, 12 1/2" Tumba
30" tall
- Material** Two ply Rubber Wood (*Hevea brasiliensis* Muell.-Arg.)
- Features** True Skin Buffalo Heads
8 mm strong tuning lugs
3.2 mm rounded SSR-Rims
Chrome plated hardware
- Includes** Steely II Conga Stand (patented)
MEINL Conga Saver (patented)
MEINL Soundpads
Accessory pouch
L-shaped tuning key
Tune Up Oil
- Colours** ARF = Aztec Red Fade
GAB = Gold Amber Sunburst
NT = Natural
- Finish** Hi Gloss



MEINL's professional conga bags provide a dependable protection and make transporting your instruments as hassle free as possible. (see page 90)



- 8 mm tuning lugs
Conga Saver (patented)
Soundpads
Chrome plated 3.2 mm rounded SSR-Rim
- Metal spike attachment on every rubber foot,
L-shaped legs (patented)
- Height adjustable
- U-shaped notches allow quick set up and breakdown (patent pending)





FIBERCRAFT® SERIES

MEINL Fibercraft® Congas offer great quality, durability, volume, and the resistance to climatic changes. They have a great presence and brilliancy in sound. Great for live playing and extensive road use.

- Sizes** 11" Quinto, 11 3/4" Conga, 12 1/2" Tumba
30" tall
- Material** Premium fiberglass
- Features** True Skin Buffalo Heads
4 mm rounded SSR-Rims
10 mm strong tuning lugs
Chrome plated hardware
- Includes** MEINL Conga Saver (patented)
MEINL Soundpads
Accessory pouch
Tuning key
Tune Up Oil
- Colours** BSP = Blue Sparkle
FR = Fire Red
JBK = Jet Black
STS = Sterling Silver



Ebenezer Da Silva, USA (Shakira):
"The MEINL Fibercraft® Congas rock!
I get the warmth in the studio and the presence on stage all in one drum."



FC11FR

FC1134FR

FC1212FR



FC11JBK

FC1134JBK

FC1212JBK



FC11BSP

FC1134BSP

FC1212BSP



FC11STS

FC1134STS

FC1212STS



10 mm tuning lugs
Conga Saver (patented)
Soundpads
Chrome plated 4 mm
rounded SSR-Rim





FLOATUNE® SERIES

The Floatune® Tuning System is a true and unique MEINL innovation. All mounting hardware is completely isolated from the shell and is secured without any drilling which allows the shell to vibrate freely.

- Sizes** 10" Nino, 11" Quinto, 12" Conga, 13" Tumba
30" tall
- Material** Two ply Rubber Wood (*Hevea brasiliensis* Muell.-Arg.)
- Features** Floatune® Tuning System
True Skin Buffalo Heads
4 mm rounded SSR-Rims
10 mm strong tuning lugs
Chrome plated hardware
- Includes** MEINL Conga Saver (patented)
MEINL Soundpads
Accessory pouch
L-shaped tuning key
Tune Up Oil
- Colours** NT = Natural
VSB = Vintage Sunburst
- Finish** Hi Gloss



10 mm tuning lugs
Conga Saver (patented)
Soundpads
Chrome plated 4 mm
rounded SSR-Rim

The Floatune® Tuning System allows the shell to vibrate freely



FL10NT

FL11NT

FL12NT

FL13NT



FL10VSB

FL11VSB

FL12VSB

FL13VSB



Manolo Badrena, USA (Zawinul Syndicate): "The Floatune® Tuning System is the most innovative conga feature I have ever seen."





PROFESSIONAL SERIES

Roland Meinl

The Roland Meinl Professional Series Congas - one of the finest instruments in the MEINL Percussion program and the preferred conga model by many top congueros. Outstanding in look and sound reaching from fat basses to cutting slaps with a great warm overall tone. They have set the standard in the professional conga ranges.



The MEINL Professional Conga Stand (patented) offers a reliable positioning within any percussion set up (see page 86).

- Sizes** 11" Quinto, 11 3/4" Conga, 12 1/2" Tumba
30" tall
- Material** Two ply Rubber Wood (*Hevea brasiliensis* Muell.-Arg.)
- Features** True Skin Buffalo Heads
10 mm strong tuning lugs
4 mm rounded SSR-Rims
Chrome plated hardware
- Includes** MEINL Conga Saver (patented)
MEINL Soundpads
Accessory pouch
L-shaped tuning key
Tune Up Oil
- Colours** CR = Cherry Red
GAB = Gold Amber Sunburst
NT = Natural
- Finish** Hi Gloss



10 mm tuning lugs
Conga Saver (patented)
Soundpads

Chrome plated 4 mm
rounded SSR-Rim



MP11GAB

MP1134GAB

MP1212GAB



MP11CR

MP1134CR

MP1212CR



MP11NT

MP1134NT

MP1212NT





ARTIST SERIES

Ramon "Mongo" Santamaria was without a doubt one of the most respected conga players ever and a pioneer of modern Latin Jazz. During the 50's his band "Black Cuban Diamonds" laid down the foundation for an outstanding career. He has recorded dozens of legendary percussion albums. Worldwide Jazz hits, such as "Watermelon Man" in 1963 and the album "Summertime" from 1980 are only two of the many recordings from this great master percussionist. Mongo has inspired more percussionists around the globe than any other conguero.

Mongo Santamaria died at the Baptist Hospital in Miami, USA in February 2003. He was 85 years old.

It is with great appreciation and deepest respect that we honour our friend and his life's work with his MEINL Artist Series Mongo Santamaria Congas.

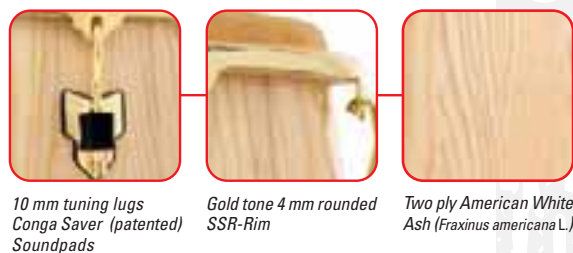

10 mm tuning lugs
Conga Saver (patented)
Soundpads

Gold tone 4 mm rounded
SSR-Rim

Two ply American White
Ash (*Fraxinus americana* L.)



MSA11AWA

MSA1134AWA

MSA1212AWA

Mongo Santamaria

- Sizes** 11" Quinto, 11 3/4" Conga, 12 1/2" Tumba
30" tall
- Material** Two ply American White Ash (*Fraxinus americana* L.)
- Features** True Skin Buffalo Heads
10 mm strong tuning lugs
4 mm rounded SSR-Rims
Gold tone hardware
- Includes** MEINL Conga Saver (patented)
MEINL Soundpads
Accessory pouch
L-shaped tuning key
Tune Up Oil
- Finish** Hi Gloss



WOODCRAFT® SERIES

The MEINL Woodcraft® Series Congas stand for tradition combined with exceptional workmanship. Only the finest hand selected materials are used to produce these premium drums. Their "Cuban Style" shaped shells provide a broad range of different tonal characteristics. It blends warm bass tones, soft open tones, and sharp slaps into one powerful drum and at the same time yields extraordinary projection.

- Sizes** 11" Quinto, 11 3/4" Conga, 12 1/2" Tumba
30" tall
- Material** Two ply American White Ash (*Fraxinus americana* L.)
- Features** True Skin Buffalo Heads
10 mm strong tuning lugs
4 mm traditional TTR-Rims
Chrome plated hardware
Handle welded to the rim
- Includes** MEINL Conga Saver (patented)
MEINL Soundpads
Accessory pouch
L-shaped tuning key
Tune Up Oil
ZFA-M = Zebra Finished Ash
- Colour** ZFA-M = Zebra Finished Ash
- Finish** Matt



Traditional, Cuban Style shell for enhanced volume



Two ply American White Ash (*Fraxinus americana* L.)



Chrome plated 4 mm traditional TTR-Rim
Handle welded to the rim



10 mm tuning lugs
Conga Saver (patented)
Soundpads



WC11ZFA-M

WC1134ZFA-M

WC1212ZFA-M



**MIPA AWARD FOR FREE RIDE SERIES
COLLECTION WOOD BONGOS**

The "Musikmesse International Press Award" is annually presented by 55 music magazines from all over the world who get together and vote the best products in certain categories. In 2001, the MEINL Collection Series Bongos won the Mipa Award in the "best percussion product" category.



**THE PATENTED MEINL
FREE RIDE SUSPENSION SYSTEM**

HAS REVOLUTIONIZED THE BONGO WORLD!



FREE RIDE SUSPENSION SYSTEM

The Macho and Hembra are no longer attached to each other by a wooden block mounted between the shells spoiling the resonance of the instrument. Whereas with the patented MEINL Free Ride Suspension System the two drums are firmly attached utilizing the bottom rims which results in not having to drill into the bongo shells. It allows for the first time ever, freely resonating bongo shells.



TRUE SKIN COW HEADS

The original MEINL True Skin Cow Heads are the perfect sounding hides for bongos and meet all requirements demanded by professional players. They have outstanding sound qualities, are easy to tune, resistant, and have a smooth surface for comfortable playing. True Skin hides are selected by specialists. After the selection process, each skin is gently tanned using a special MEINL procedure and then mounted by hand to become a first class True Skin Head.

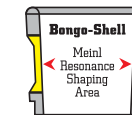

RESONANCE SHAPING AREA

The MEINL Resonance Shaping Area is a fine solution to enhance the resonance of the bongos. The center part of the two bongo shells are crafted thinner than usual while still maintaining its full stability. The result is a superior timbre and better resonance of the instrument.



SSR

The MEINL Safe & Sound-Rim (SSR) for bongos features a rounded profile to support a comfortable playing feel and to assist in the prevention of palm injuries.



TTR

The MEINL Traditional-Tuning-Rim (TTR) for bongos represents the traditional "Cuban Style". They are narrowly placed around the shells and enhance the overall bongo sound.

FREE RIDE SERIES (patented) COLLECTION WOOD BONGOS

MEINL Collection Series Wood Bongos are the finest bongos available today. They are made entirely by hand and exhibit unparalleled sound, charm, and workmanship. MEINL's expertise in wood selection enabled to study the sonic properties of a large variety of exclusive woods. These extensive studies now reflect in the excellence of these collectors item bongos. The patented MEINL Free Ride System allows freely resonating bongo shells.

- Sizes** 7" Macho & 8 1/2" Hembra
- Materials** AWA-M = American White Ash (*Fraxinus americana* L.)
ROW-M = Rose Wood (*Pterocarpus macrocarpus* Kurz)
TW-M = Teak Wood (*Tectona grandis* L.f.)
- Features** MEINL Free Ride Suspension System (patented)
Chrome plated hardware
True Skin Cow Heads
8 mm strong tuning lugs
3 mm rounded SSR-Rims
Resonance Shaping Area
- Includes** Accessory pouch
L-shaped tuning key
Tune Up Oil
- Finish** Matt



BONGOS



COLLECTION BONGOS WOODCRAFT® BONGO

FREE RIDE SERIES (patented) WOODCRAFT® BONGO

The MEINL Woodcraft® Bongo, just as the Woodcraft® Congas, stands for tradition combined with exceptional workmanship. Only the finest hand selected materials are used to produce this premium bongo which produces the authentic and typical loud slapping bongo sound. The patented MEINL Free Ride System allows freely resonating bongo shells.

- Sizes** 7" Macho & 9" Hembra
- Material** American White Ash (*Fraxinus americana* L.)
- Features** MEINL Free Ride Suspension System (patented)
Chrome plated hardware
True Skin Cow Heads
8 mm strong tuning lugs
4 mm traditional TTR-Rims
Resonance Shaping Area
- Includes** Accessory pouch
L-shaped tuning key
Tune Up Oil
- Colour** ZFA-M = Zebra Finished Ash
- Finish** Matt



Original True Skin Cow Heads
Chrome plated 4 mm traditional TTR-Rims

Free Ride Suspension System (patented)



WOOD EXPERTISE

WOOD EXPERTISE

Following years of research and development, MEINL presents a variety of exquisite collector items. Their expertise in wood selection enabled them to study the sonic properties of a variety of exclusive woods.

MEINL considers the preservation of each species of the utmost importance and the only wood that is chosen meets all the CITES-regulations set forth in the "Convention on International Trade in Endangered Species of Wild Fauna and Flora". These woods are harvested from environmentally controlled forests or from industrial wood plantations.

American White Ash (*Fraxinus americana* L.)

Rose Wood (*Pterocarpus macrocarpus* Kurz)

Teak Wood (*Tectona grandis* L.f.)

Rubber Wood (*Hevea brasiliensis* Muell.-Arg.)



FREE RIDE SERIES (patented) FWB400 WOOD BONGOS

The MEINL FWB400 Free Ride Series Wood Bongos are the preferred bongo model by many top percussionists. Exceptional sound qualities combined with a wide variety of colours make it the perfect bongo for the working musician. The patented MEINL Free Ride System allows freely resonating bongo shells.

- Sizes** 7" Macho & 8 1/2" Hembra
- Material** Rubber Wood (*Hevea brasiliensis* Muell.-Arg.)
- Features** MEINL Free Ride Suspension System (patented)
Chrome plated hardware
True Skin Cow Heads
8 mm strong tuning lugs
3 mm rounded SSR-Rims
Resonance Shaping Area
- Includes** Accessory pouch
L-shaped tuning key
Tune Up Oil
- Colours** AB = African Brown
CR = Cherry Red
GAB = Gold Amber Sunburst
NT = Natural
- Finish** Hi Gloss

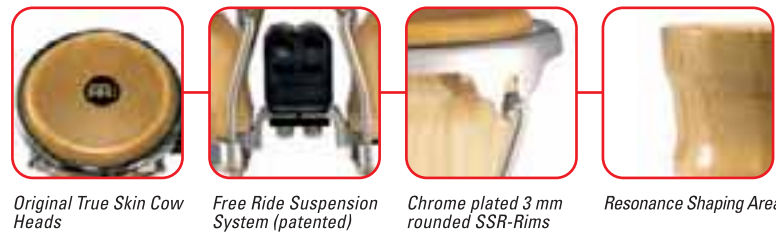

Original True Skin Cow Heads Free Ride Suspension System (patented) Chrome plated 3 mm rounded SSR-Rims Resonance Shaping Area



FWB400CR



FWB400NT



FWB400GAB



FWB400AB

FREE RIDE SERIES (patented) FWB200 WOOD BONGOS

The MEINL FWB200 Free Ride Series Wood Bongos are made from high quality components and produce a superb tone. The patented MEINL Free Ride System allows freely resonating bongo shells.

- Sizes** 6 3/4" Macho & 8" Hembra
- Material** Rubber Wood (*Hevea brasiliensis* Muell.-Arg.)
- Features** MEINL Free Ride Suspension System (patented)
Chrome plated hardware
Hand selected buffalo heads
8 mm strong tuning lugs
2.5 mm rounded SSR-Rims
- Includes** Accessory pouch
L-shaped tuning key
Tune Up Oil
- Colours** ARF = Aztec Red Fade
GAB = Gold Amber Sunburst
NT = Natural
- Finish** Hi Gloss



FWB200GAB

FWB200ARF

FWB200NT

FREE RIDE SERIES (patented) FWB190 WOOD BONGOS

The MEINL FWB190 Free Ride Series Wood Bongos are perfect for the ambitious beginner and for those who look for an affordable second set. Its professional features are outstanding in this price range. The patented MEINL Free Ride System allows freely resonating bongo shells.

- Sizes** 6 3/4" Macho & 8" Hembra
- Material** Rubber Wood (*Hevea brasiliensis* Muell.-Arg.)
- Features** MEINL Free Ride Suspension System (patented)
Black powder coated hardware
Hand selected buffalo heads
8 mm strong tuning lugs
2.5 mm rounded SSR-Rims
- Includes** Accessory pouch
L-shaped tuning key
Tune Up Oil
- Colours** CN-M = Chest Nut
GSB-M = Gold Sunburst
SNT-M = Super Natural
- Finish** Matt



FWB190GSB-M

FWB190CN-M

FWB190SNT-M



FREE RIDE SERIES (patented) FFB400 FIBERGLASS BONGOS

The MEINL FFB400 Free Ride Series Fiberglass Bongos have a stunning sound reaching from powerful mids to sharp highs. Due to their fiberglass shells they are extremely durable and the perfect instrument for the working musician on the road. The patented MEINL Free Ride Suspension System allows freely resonating bongo shells.

- Sizes** 7" Macho & 8 1/2" Hembra
- Material** Premium fiberglass
- Features** MEINL Free Ride Suspension System (patented)
Chrome plated hardware
True Skin Cow Heads
8 mm strong tuning lugs
3 mm rounded SSR-Rims
Resonance Shaping Area
- Includes** Accessory pouch
L-shaped tuning key
Tune Up Oil
- Colours** BSP = Blue Sparkle
FR = Fire Red
JBK = Jet Black
STS = Sterling Silver



Resonance Shaping Area Chrome plated 3 mm rounded SSR-Rims

Many percussionists prefer the sound of fiberglass bongos. There is a reason for this: Fiberglass produces a more compact sound with an appealing spectrum of overtones. Meinl's patented Free Ride Suspension System combined with the fiberglass bongo shells produces a greater definition and increased volume. The shells of the Free Ride Fiberglass Bongos are manufactured by hand laminating layer upon layer of premium fiberglass. This type of manufacturing process requires extreme patience and dexterity. The result is a truly professional instrument with a unique sound quality.



FREE RIDE SERIES (patented) FFB200 FIBERGLASS BONGOS

The MEINL FFB200 Fiberglass Bongos produce a compact sound with a nice spectrum of overtones. They are made from the finest components and are outstanding in quality and workmanship. Ideal for the ambitious beginner who looks for a semi-professional bongo at an affordable price. The patented MEINL Free Ride Suspension System allows freely resonating bongo shells.

- Sizes** 6 3/4" Macho & 8" Hembra
- Material** Premium fiberglass
- Features** MEINL Free Ride Suspension System (patented)
Chrome plated hardware
Hand selected Buffalo Heads
8 mm strong tuning lugs
2.5 mm rounded SSR-Rims
- Includes** Accessory pouch
L-shaped tuning key
Tune Up Oil
- Colours** BSP = Blue Sparkle
FR = Fire Red
JBK = Jet Black
STS = Sterling Silver



Free Ride Suspension System (patented)





Marcie Chapa, USA (independent)



MIPA AWARD FOR MEINL ARTIST SERIES LUIS CONTE SIGNATURE TIMBALES

The "Musikmesse International Press Award " is annually presented by 55 music magazines from all over the world who get together and vote the best products in certain categories. In 2000, the MEINL Artist Series Luis Conte Timbales won the Mipa Award in the "best percussion product" category.



DIVERSITY IN MATERIALS

MEINL has a great variety of different sounding timbales due to the diversity of materials used in making the shells. Available models include German B8 cymbal bronze, solid brass, stainless steel, black powder coated steel, chrome plated steel, and brass plated steel.



HAMMERED SHELLS

Extensively hammered shells (Artist Series Luis Conte Timbales) provide the classic dry cascara sound and support the sharpness and projection of the drums.



PATENTED FLOATUNE® TUNING SYSTEM

The patented Floatune® Tuning System works without having to drill into the shell (Artist Series Amadito Valdès and Floatune® Series timbale models). The bottom rim is positioned around the shell before the bottom is flanged. When the head is tensioned the lower rim is drawn upward against the tuning flange and the head and upper rim are drawn downward over the shell.



FLARED OUT BOTTOM EDGE

The Cuban Style flared out bottom edge increases the projection of the timbale (Artist Series Luis Conte and Professional Series Timbales).



WORKED IN FLANGES

Two flanges are worked into the shell to increase stability.



CAST BRACKETS

Brackets cast from special brass alloy (Artist Series Luis Conte and Professional Series Timbales).



PROFESSIONAL SERIES

Roland Stein

The Roland Meinl Professional Series Timbales are made from finest German B8 cymbal bronze. They produce a fantastic warm sound with cutting rim shots and enhanced cascara playing.

Sizes 14" & 15"

Material German B8 cymbal bronze

Features Two worked in flanges
Cuban style flared out bottom edge
Brackets cast from special brass alloy

Includes Adjustable cowbell holder
Height adjustable tilting double braced tripod stand
Accessory pouch
L-shaped tuning key
Tune Up Oil



Counter sunk bolt heads
Brackets cast from special alloy



Cuban style flared out bottom edge



Made from German B8 cymbal bronze



BT1415



ARTIST SERIES

Luis Conte

Grammy-winner Luis Conte is an acknowledged master of percussion. His celebrated career includes touring and/or recording with some of the greatest names in contemporary music, including Madonna, Eric Clapton, Phil Collins, James Taylor, Santana, Celine Dion, Barbara Streisand, Backstreet Boys, Ray Charles and Cuban legends Arturo Sandoval and Chachao. He can also be heard on the scores and/or soundtracks to such movies like Mission Impossible, Rain Man, Disney's animated Tarzan, and many more.

It is with great appreciation and deepest respect that we honor our friend and his life's work with his MEINL Artist Series Luis Conte Signature Timbales. Perfection in even the smallest detail is realized in this superlative instrument. All of the specifications Luis required for his instrument have been consequently realized.

Sizes 14" & 15"

Material Solid brass or stainless steel

Features Extensively hammered shells
Two worked in flanges
Cuban style flared out bottom edge
Brackets cast from special brass alloy

Includes Adjustable cowbell holder
Height adjustable tilting double braced tripod stand
Accessory pouch
L-shaped tuning key
Tune Up Oil



LC1BRASS



LC1STS



Extensively hammered shell



Counter sunk bolt heads
Brackets cast from special alloy



TIMBALES



PROFESSIONAL SERIES
ARTIST SERIES



LUIS CONTE, USA





ARTIST SERIES
FLOATUNE® SERIES
MARATHON® SERIES

ARTIST SERIES (patented)

Amadito Valdès

Amadito Valdès “the timbal magician” was born in Havana, February 14th 1946. He studied at the Havana Conservatoire with maestros Guillermo Barreto and Alfredo de los Reyes. He is the creator of a unique style of improvising on the timbales, which mixes Afro rhythms in 6/8 with the son syncopated rhythms in 2/4. Valdès has worked with all the most important Cuban big bands since the '70s and recorded countless albums with artists of the stature of Las D'Aide, Paquito Revera, Emiliane Salvador, Bebo Valdès, Las Estrellas de Areito and Peruchin. Since 1997, he has recorded and toured the globe with artists such as Juan do Marco and the Afro-Cuban-Allstars, Rubèn González, Felix Baloy. He is featured in Wim Wender's famous movie Buena Vista Social Club and has also performed at the 42nd annual Grammy Awards 2000 in Los Angeles featuring Grammy Winner Ibrahim Ferrer. The MEINL Artist Series Amadito Valdès Timbales – a tribute to one of the greatest timbaleros ever.

- Sizes** 14" & 15"
- Material** Black powder coated steel
- Features** Two worked in flanges
Patented Floatune® Tuning System
- Includes** Adjustable cowbell holder
Height adjustable tilting double braced tripod stand
Accessory pouch
L-shaped tuning key
Tune Up Oil



AV1BK



Patented MEINL Floatune® Tuning System



Amadito Valdès, Cuba

FLOATUNE® SERIES (patented)

The patented MEINL Floatune® Tuning System used on these timbales works without having to drill into the shell. The result is a voluminous timbale sound with a crisp and warm response, cutting rim shots and a great cascara sound.

- Sizes** 13" & 14"
- Material** Black powder coated steel
- Features** Two worked in flanges
Patented Floatune® Tuning System
- Includes** Adjustable cowbell holder
Height adjustable tilting double braced tripod stand
Accessory pouch
L-shaped tuning key
Tune Up Oil



T11BK

MARATHON® SERIES

MEINL Marathon® Series Timbales are professionally equipped yet are offered at a more affordable price. They are perfect for the working percussionist or to be included in a drum setup.

- Sizes** 14" & 15"
- Material** Steel
- Features** Two worked in flanges
Heavy duty style brackets
- Includes** Adjustable cowbell holder
Height adjustable tilting double braced tripod stand
Accessory pouch
L-shaped tuning key
Tune Up Oil
- Finish** Brass
Chrome



Adjustable cowbell holder



MT1415CH

MT1415B

DRUMMER TIMBALE MINI TIMBALE

The MEINL Drummer and Mini Timbale provide the characteristic timbale sounds and project enough to cut through any band setting. A strong mounting clamp attaches firmly to any common tom holders or L-rods. It is a perfect addition to any percussion- or drum set configuration and adds extra flavour to the groove.

- Sizes** 13" drummer timbale
8" & 10" mini timbale
- Material** Chrome plated steel
- Features** Strong mounting clamp
Original timbale brackets and tuning lugs
- Includes** L-shaped tuning key
Tune Up Oil



Strong mounting clamp attaches to any common L-rod



Original timbale style brackets & tuning lugs



MDT13CH

MIT810CH





DIVERSITY IN MATERIALS

MEINL uses three different material to produce premium djembes: Rubber Wood (*Hevea brasiliensis* Muell.-Arg.), American White Ash (*Fraxinus Americana* L.), and premium fibreglass. This diversity covers all djembe sounds ever required in any musical setting.



TRUE SKIN GOAT HEADS

The original MEINL True Skin Goat Heads on djembes offer the widest dynamic range from cutting slaps to powerful bass tones. True Skin hides are selected by specialists. After the selection process, each skin is gently tanned using a special MEINL procedure and then mounted by hand to become a first class True Skin Head.



TRUE SKIN CALF HEADS

The original MEINL True Skin Calf Heads on the MEINL Rope Tune Djembe offer an alternative sound with fewer overtones and a warmer overall spectrum. True Skin hides are selected by specialists. After the selection process, each skin is gently tanned using a special MEINL procedure and then mounted by hand to become a first class True Skin Head.



TRUE SKIN COW HEADS

The original MEINL True Skin Cow Heads on the MEINL Mother Djembe is extremely resistant and withstands even the hardest hits. They provide a full and rich sound on this huge drum. True Skin hides are selected by specialists. After the selection process, each skin is gently tanned using a special MEINL procedure and then mounted by hand to become a first class True Skin Head.



PATENTED FLOATUNE® TUNING SYSTEM

The patented MEINL Floatune® Tuning System makes drilling holes into the shell unnecessary while enhancing the resonance of the drum and increase its projection.



ROPE TUNING SYSTEM

The MEINL Rope Tune Djembe features the traditional tuning system using a resistant rope.



MOTHER DJEMBE

The MEINL Mother Djembe is the biggest djembe on the market today. It has a 21" diameter and is 42" tall. Its sound is unbelievably voluminous and rich.



FLOATUNE® SERIES

FLOATUNE® SERIES WOOD DJEMBES (patented)

The MEINL patented Floatune® Wood Djembes are modelled after the West African originals. They provide the typical traditional sounds yet equipped with modern technical innovations and features. A common drum known for its dynamic sounds and the most widely used African drum today.

- Sizes** 12" DJW3
12 3/4" DJW2
- Material** Rubber Wood (*Hevea brasiliensis* Muell.-Arg.)
- Features** True Skin Goat Heads
8 mm strong tuning lugs
3 mm rounded SSR-Rims
Easy tuning and comfortable change of heads
Rubber pads and relocated lugs offer perfect playing comfort
Patented Floatune® Tuning System
Chrome plated hardware
- Includes** Accessory pouch
L-shaped tuning key
Tune Up Oil
- Colours** AB-M = African Brown, matt
ARF = Aztec Red Fade, hi gloss
GAB = Gold Amber Sunburst, hi gloss
NT = Natural, hi gloss



The head can be tuned very simply



Special rubber pads for perfect playing comfort



Relocated tuning lugs offer perfect playing comfort

FLOATUNE® SERIES FIBERGLASS DJEMBES (patented)

The MEINL patented Floatune® Series Fiberglass Djembes are truly a sound alternative. Fiberglass has enormous strength and can produce slaps of outstanding transparency and immensely powerful bass tones. This perfectly manufactured instrument is the preferred model by many top percussionists on stage and a great alternative to wooden djembes.

- Size** 12"
- Material** Premium fiberglass
- Features** True Skin Goat Heads
8 mm strong tuning lugs
3 mm rounded SSR-Rims
Easy tuning and comfortable change of heads
Rubber pads and relocated lugs offer perfect playing comfort
Patented Floatune® Tuning System
Chrome plated hardware
- Includes** Accessory pouch
L-shaped tuning key
Tune Up Oil
- Colours** BSP = Blue Sparkle
FR = Fire Red
JBK = Jet Black
STS = Sterling Silver





FLOATUNE® SERIES ROPE TUNE

FLOATUNE® SERIES WOOD DJEMBE (patented)

The MEINL patented Floatune® Wood Djembe is made from finest American White Ash (*Fraxinus Americana L.*) which produces an excellent voluminous djembe sound. Its gold tone hardware adds a beautiful look to this excellent drum.

- Size** 12"
- Material** American White Ash (*Fraxinus americana L.*)
- Features** True Skin Goat Head
8 mm strong tuning lugs
3 mm rounded SSR-Rim
Easy tuning and comfortable change of heads
Rubber pads and relocated lugs offer perfect playing comfort
Patented Floatune® Tuning System
Gold Tone Hardware
- Includes** Accessory pouch
L-shaped tuning key
Tune Up Oil
- Finish** Hi Gloss



Gold tone hardware American White Ash (*Fraxinus americana L.*) Gold tone 3 mm rounded SSR-Rim



DJW3AWA

FLOATUNE® SERIES MOTHER DJEMBE (patented)

The patented MEINL Floatune® Mother Djembe is the biggest djembe on the market today. With its 21" diameter and 42" height it produces an extremely voluminous and powerful sound that is incomparable to any other drum today. It is perfect to be added as an additional bass drum in a percussion- or drum set up.

- Size** 21"
42" tall
- Material** Rubber Wood (*Hevea brasiliensis Muell.-Arg.*)
- Features** True Skin Cow Head
10 mm strong tuning lugs
Traditional TTR-Rim
Patented Floatune® Tuning System
Black powder coated hardware
- Includes** Accessory pouch
L-shaped tuning key
Tune Up Oil
- Colour** GSB-M = Gold Sunburst
- Finish** Matt



DJW21GSB-M

ROPE TUNE WOOD DJEMBES

The MEINL Rope Tune Wood Djembes are crafted with great attention to detail. They feature the traditional rope tuning system. A great sounding drum at an affordable price.

- Size** 12"
- Material** Rubber Wood (*Hevea brasiliensis Muell.-Arg.*)
- Features** True Skin Calf Heads
Traditional rope tuning system
- Colours** AB-M = African Brown
NT-M = Natural
SNT-M = Super Natural
- Finish** Matt



Traditional Rope Tune System



DJWR3AB-M

DJWR3NT-M

DJWR3SNT-M



GLOW IN THE DARK FINISH CONGAS, BONGOS, DJEMBE

The unique "Glow In The Dark" finish is an original MEINL innovation and one-of-a-kind in today's percussion world. By applying a fluorescent layer of lacquer, the drums actually start to "glow in the dark". This results in an awesome visual effect on stage, especially in small clubs with dim lights. This finish is by far the most in demand look of today's Live Dance and Techno Scene.

SPECIFICATIONS:

MEC11GLOW	Marathon® Exclusive Series 11" Quinto, wood
MEC1134GLOW	Marathon® Exclusive Series 11 3/4" Conga, wood
MEC1212GLOW	Marathon® Exclusive Series 12 1/2" Tumba, wood
FWB400GLOW	Free Ride® Series 7" & 8 1/2" Bongo, wood
FWB100GLOW	Free Ride® Series 3 1/2" & 4 1/2" Minibongo, wood
DJW3GLOW	Floatune® Series Djembe 12", wood

FOR MORE DETAILED PRODUCT INFORMATION SEE RELATED PRODUCT PAGES.

GLOW IN THE DARK

CONGAS, BONGOS
DJEMBE



DJW3GLOW



MEC11GLOW

MEC1134GLOW

MEC1212GLOW



FWB100GLOW

FWB400GLOW



REALPLAYER STEELBELLS

MEINL's Realplayer Steelbells are hand made using a special steel alloy. The parts are welded together in a continuous seam and sealed with a protective coating. A large variety of bells offer different pitches and sound characteristics designed to meet all musical needs.

STEEL FINISH MODELS

The pitches of these Steelbells form a diatonic scale which makes it easy to use multiple bell combinations in any musical setting.

- Sizes** 4 1/2" low pitch
4 1/2" medium pitch
4 1/2" high pitch
6 1/4"
8" small mouth
8" big mouth
- Material** Special steel alloy
- Features** Tonally matched
- Finish** Hand brushed steel



STB45L STB45M STB45H STB625 STB80S STB80B

CHROME FINISH MODELS

These highly polished chrome finished models are not only visually bright, they also satisfy all of the sonic requirements for South American rhythms.

- Sizes** 4 1/2" low pitch
6 1/4"
8" small mouth
8" big mouth
- Material** Special steel alloy
- Features** Bright sound
- Finish** High polished chrome



STB45L-CH STB625-CH STB80S-CH STB80B-CH

HAND HAMMERED MODELS

The strong fundamental tone of these Steelbells make them a unique alternative to all other bells on the market. Each Steelbell has its own character.

- Sizes** 6 1/4"
8" big mouth
- Material** Special steel alloy
- Features** Hand hammered
- Finishes** Hand brushed gold
Hand brushed copper
Hand brushed steel



STB625HH-G STB625HH-C STB625HH-S STB80BHH-G STB80BHH-C STB80BHH-S

ARTIST SERIES

Kenny Aronoff

Kenny Aronoff says: "My Artist Series Signature Cowbells are the ultimate drummer's bells. Playing live they cut through and have very nice tones. Their recording characteristics are outstanding too."

- Sizes** 6 1/4"
8" small mouth
- Material** Special steel alloy
- Features** Hand hammered
- Finish** High polished chrome



KA625 KA80S

HAND MODELS

These Bongo Bells easily cut through any high volume performance and are comfortable to hold. They are perfect for a classic bongo pattern.

- Sizes** 6.5"
7.85"
8.15"
- Material** Special steel alloy
- Finish** Hand brushed steel

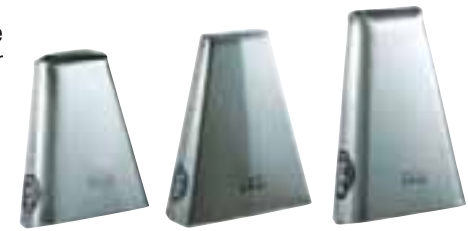

STB65H STB785H STB815H

HANDHELD MODELS

The unique feature of the MEINL Handheld Models is a wide and comfortable grip. Ideal for street percussion.

- Sizes** 4 1/2"
6 1/4"
- Material** Special steel alloy
- Features** Comfortable holder
- Finish** Hand brushed steel



STB45HA-CB STB625HA-CB

A-GO-GO STEEL FINISH MODELS

These MEINL A-Go-Go Bells are tonally matched especially for the requirements of South American rhythms.

- Sizes** Small
Large
- Material** Special steel alloy
- Includes** Mounting clamp for small model
- Finish** Hand brushed steel



STBAG1 STBAG2

A-GO-GO CHROME FINISH MODELS

These highly polished A-Go-Go Bells offer a bright sound and are equipped with a flexible connection. Ideal for Samba style music.

- Sizes** Small
Large
- Material** Special steel alloy
- Feature** Flexible connection
- Finish** High polished chrome



STBAG4-CH STBAG2-CH

HANDMATE

The MEINL Handmate is a professional cowbell beater which can be mounted in a setup. This allows hitting the cowbell by hand while playing another instrument.

- Material** Steel construction with a wooden ball
- Features** Fully adjustable



HAM1BK

COWBELL BEATERS

MEINL offers a regular and professional cowbell beater for more sound options.

- Material** Rubber Wood (*Hevea brasiliensis* Muell.-Arg.)
- Features** Ribbed grip
Padded beater section



COW1

COW2

CHIMES

MEINL Chimes provide great tonal diversity and are available in a wide assortment of sounds. Percussionists and drum set players will find various chime models to fit any application. All MEINL Chimes are made from a premium anodized aluminum alloy-, and a well balanced wooden bar. A durable nylon cord is used to attach them firmly together.

ARTIST SERIES

L. Conte

"I wanted a wide spectrum!" comments Luis Conte. "The shorter bars deliver great high pitched sounds. I can get a full and bright chime sound from the medium and low pitched bars. They sound perfect especially in the studio."

Size 60 bars, double row
Material Silver anodized aluminum alloy
Features High frequency chime
Includes Holder
 Striker

LC60HF



CHIMES, 66 BARS

The 66 bar chimes produce a rich and full sound. They cut through any band setting.

Size 66 bars, double row
Material Gold anodized aluminum alloy
Features High frequency chime
Includes Holder
 Striker

CH66HF



CHIMES, 33 BARS

The 33 bar chimes produce a very bright sound with a pronounced upper overtone spectrum. They are perfect for all live situations.

Size 33 bars, single row
Material Gold anodized aluminum alloy
Features High frequency chime
Includes Holder
 Striker

CH33HF



ROCK CHIMES, 33 BARS

The bars of MEINL Rock Chimes are thicker for a richer and more voluminous sound.

Size 33 bars, single row
Material Gold anodized aluminum alloy
Features High frequency chime
Includes Holder
 Striker

CH33HF-R



CHIMES, 27 BARS

The 27 bar chimes produce a full sound with a wide tonal spectrum. Ideal for smaller stages and club scenes.

Size 27 bars, single row
Material Gold anodized aluminum alloy

CH27



STUDIO CHIMES, 27 BARS

The Studio Chimes feature slightly thinner bars for a full, rich and tasteful sound.

Size 27 bars, single row
Material Gold anodized aluminum alloy

CH27ST

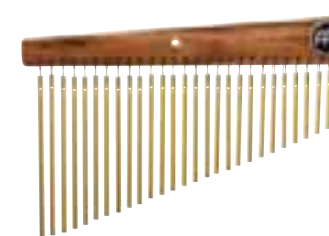

CHIMES, 12 BARS

The 12 bar chimes produce a beautiful, high pitched sound. Not too obtrusive, ideal for tasteful chime accents.

Size 12 bars, single row
Material Gold anodized aluminum alloy

CH12



HAND CHIMES

The three differently sized models of these hand chimes are tonally matched. They can easily be played by hand only and still produce a full and rich sound.

Sizes 12 bars
 18 bars
 24 bars
Material Gold anodized aluminum alloy



CH-H12

CH-H18

CH-H24

PEG CHIME

The Peg Chimes are extremely high pitched. They are perfect for special accents.

Size 12 pegs
Material Gold plated steel



CH-HPEG

TRI TONE CHIMES

The three free floating bars create a very long sustain and are tonally matched.

Material Gold anodized aluminum alloy
Features Mountable on all common L-rods
Includes Wooden beater
 Holder



CH3

TRIANGLES

The solid brass triangles produce a nice sounding soft tone with a controlled sonic spectrum.

Sizes 4"
 6"
 8"
Material Solid brass
Includes Wooden holder with braided nylon cord
 Metal beater

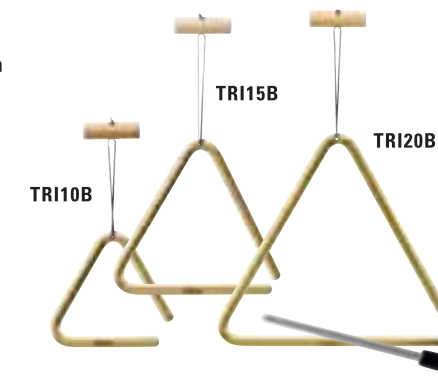

TRI15B

TRI20B

TRI10B

CHIMES TRIANGLES



All trusses are made from Jamjuree Wood. The chimes are attached through a braided nylon cord.



TAMBOURINES

MEINL Hand and Set Up Tambourines (design protected by a utility model) have a distinct design advantage due to the construction of the ABS frame. Unlike other tambourines, MEINL's utilizes several different part in the frame which are assembled into a type of "sandwich". This results in unsurpassed durability. Due to their shape and ergonomical design the tambourines are perfectly balanced and outstanding in sound and quality. A wide range with different type jingles is available for all sound applications.

TAMBOURINES, STEEL JINGLES

These ergonomically shaped tambourines are available as hand held or mountable versions. The durable ABS frame allows hard hitting and energetic hand playing. Nickelsilver plated steel jingles produce a bright sound that projects well.

- Material** Jingles: Nickelsilver plated steel
Frame: ABS
- Features** Ergonomic design
Available as hand held or mountable versions
Guiro style playing surface
"Sandwich" construction
- Colours** BK = Black
R = Red



Steel jingles produce a bright sound that projects well

TMT2BK



TMT1BK



TMT2R



TMT1R



A "Guiro" kind of sound can also be produced by scraping the ribbed edge of the frame

TAMBOURINES, BRASS JINGLES

The MEINL Brass Tambourines are ergonomically shaped and available as hand held or mountable versions. The durable ABS frame allows hard hitting and energetic hand playing. They deliver a very warm, yet cutting sound.

- Material** Jingles: Solid brass
Frame: ABS
- Features** Ergonomic design
Available as hand held or mountable versions
Guiro style playing surface
"Sandwich" construction
- Colours** BK = Black



Solid brass jingles produce a very warm, yet cutting sound

TMT2B-BK



TMT1B-BK



TAMBOURINE, ALUMINUM JINGLES

The MEINL Aluminum Hand Tambourine is extremely light weight for extensive and energetic playing. Their sound is very soft and harmonic.

- Material** Jingles: Aluminum
Frame: ABS
- Features** Ergonomic design
Light weight
"Sandwich" construction
Hand held version
- Colour** B = Blue



Aluminum jingles produce a very soft and harmonic tone



TMT1A-B

WOOD TAMBOURINES, STEEL JINGLES

Featuring 1 or 2 row versions. The MEINL Wood Tambourines with nickelsilver plated steel jingles produce a bright sound that projects well.

- Sizes** 1 row
2 rows
- Material** Jingles: Nickelsilver plated steel
Wooden frame
- Colour** AB = African Brown

TA1AB



TA2AB



WOOD TAMBOURINES, BRASS JINGLES

Featuring 1 or 2 row versions. Solid brass jingles deliver a distinctively warm, and cutting sound.

- Sizes** 1 row
2 rows
- Material** Jingles: Solid brass
Wooden frame
- Colour** AB = African Brown

TA1B-AB



TA2B-AB



JINGLE STICKS

MEINL Jingle Sticks create many interesting sound possibilities. Available are models with jingles made from nickelsilver plated steel, solid brass, or aluminum for many sound applications.

- Jingles** Nickelsilver plated steel
Solid brass
Aluminum
- Features** Padded grip
Guiro style playing surface



JG1B-BK

JG1A-B

JG1BK

JG1R

PLASTIC GUIRO

The MEINL Plastic Guiro is precision molded from high strength plastic. It features three different striking surfaces and rubber ringed grip holes for maximum comfort and control. It has a slightly dryer and warmer sound than the fiberglass model, yet brighter and louder than a natural gourd guiro.

- Material** High strength plastic
- Features** Three striking surfaces
Rubber ringed grip holes
- Includes** Plastic Scraper
- Colour** BK = Black



GU6BK



The MEINL Guiro Holder, see page 83

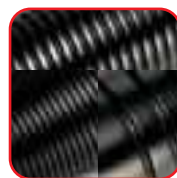

3 playing surfaces

FIBERGLASS GUIROS

The MEINL Fiberglass Guiro has become extremely popular among percussionists worldwide. It offers three different striking surfaces for enhanced sounds and rubber ringed grip holes.

- Material** Premium fiberglass
- Features** Three striking surfaces
Rubber ringed grip holes
- Includes** Plastic scraper
- Colours** BK = Black
R = Red



GU7R

GU7BK

WOOD GUIRO

The traditional MEINL Wood Guiro produces a warm, and cutting sound. With its two grip holes it is very easy and comfortable to play.

- Material** Wood
- Features** Grip holes
- Includes** Wooden scraper
- Colour** AM = Amber



GU1AM

CABASAS, WOOD

The MEINL Wood Cabasas are available in three different sizes and produce a clear and voluminous sound. Made from high quality components, it is very durable and long lasting.

- Sizes** Small
Regular
Large
- Material** Steel chain and stainless steel cylinder
- Colour** AM = Amber



CA2AM

CA1AM

CA3AM



The MEINL Cabasa Holder, see page 83

CABASA, FIBERGLASS

The shape and function of the MEINL Fiberglass Cabasa equals a traditional gourd calabash. The MEINL fiberglass version however offers positive stability and dynamic sound quality.

- Material** Premium fiberglass
- Colour** R = Red



CA7R

SHEKERE

The MEINL Shekere is handmade from premium fiberglass and fitted with a net of synthetic pearls. It delivers a rich, full sound and unlike gourd shekerae it is nearly unbreakable.

- Material** Premium fiberglass
- Colour** BK = Black



Adjustable net for various tensions and sound options



SH1BK

SHEKERE, JUMBO SIZE

MEINL's Jumbo Size Shekere is hand made from premium fiberglass and fitted with a net of synthetic pearls. Because of its large body size it produces a wide tonal range of sounds ranging from low bass tones when struck on the bottom to loud, high pitched shaker and rattle sounds.

- Material** Premium fiberglass
- Colour** VSB = Vintage Sunburst



SH2VSB



PERCUSSION BLOCKS, HIGH PITCH

The MEINL Percussion Block is made to withstand even the hardest players. It delivers a cutting high pitched sound and is easily mounted on any conventional L-rod.

- Material** PE
- Features** High pitched sound
Durable
- Includes** Mounting Clamp
- Colours** BK = Black
R = Red



PERCUSSION BLOCKS, LOW PITCH

The MEINL Percussion Block is made to withstand even the hardest players. It delivers a low pitched sound and is easily mounted on any conventional L-rod.

- Material** PE
- Features** Low pitched sound
Durable
- Includes** Mounting Clamp
- Colours** BK = Black
R = Red



WOOD BLOCKS

The two versions of the MEINL Wood Blocks are tonally matched, highly durable and produce voluminous sound with wood accents. Ideal for keeping time.

- Sizes** Small
Large
- Material** Rubber Wood (*Hevea brasiliensis* Muell.-Arg.)
- Features** Rounded playing surface
- Includes** Wooden beater



WOOD CLAVES, CLASSIC

The MEINL Classic Wood Claves are the most common claves and produce the classic cutting sound. Both the clave and the striker have the same size.

- Material** Hardwood
Redwood
- Features** Solid body



WOOD CLAVES, AFRICAN

African Claves are slightly larger and have a lower fundamental pitch. Additionally, the resonating body is larger than the striker. Available in two different versions: Solid- and hollowed out body.

- Material** Hardwood
Redwood
- Features** Solid body
Hollowed out body



FIBERGLASS CLAVES

The MEINL Fiberglass Claves produce the most penetrating, loud, and cutting sound of all. It is hand made from premium fiberglass which makes it nearly indestructible.

- Material** Premium fiberglass
- Features** Solid body
Cutting sound
- Colours** BK = Black
R = Red

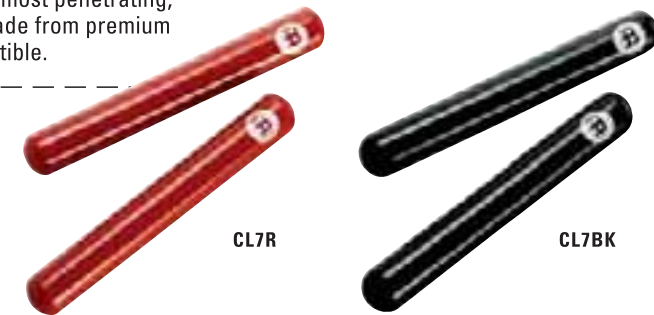

WOOD EGG SHAKERS

The MEINL Wood Egg Shakers are turned from wood and deliver a soft yet rich sound. They are perfect in situations which require clearly defined accents.

- Size** Jumbo
- Material** Wood
- Colours** AM = Amber
BK = Black
R = Red



PLASTIC EGG SHAKERS

The MEINL Plastic Egg Shakers are preferred due to their smooth and crystal clear sound. These have applications in practically any musical setting.

- Material** Plastic
- Colours** B = Blue
BK = Black
GREEN = Green
R = Red
Y = Yellow

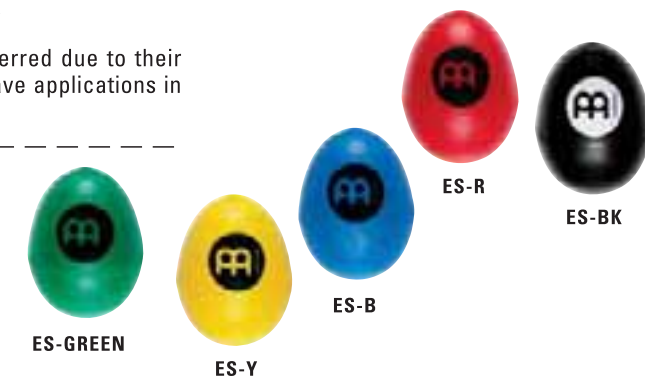

SKIN MARACAS

The MEINL Skin Maracas are entirely made by hand and are offered in four different sizes for a wide sonic range. The two larger models sound especially full and dry, whereas the smaller sized versions produce a very tight and high pitched sound.

Sizes Mini
Midi
Traditional
Jumbo
Material Natural skin
Wooden handle



PLASTIC MARACAS

The MEINL Plastic Maracas produce a loud and crisp sound. They are very durable and comfortable to play.

Material Plastic
Wooden handle



Material Plastic
Colours B = Blue
BK = Black
Y = Yellow



WOOD MARACAS

The traditional MEINL Wood Maracas are available in both round and oval models. Both of these exhibit a traditional warm and rich sound.

Material Wood



DOUBLE SHAKER

The MEINL Double Shaker is woven by hand and includes a coconut bottom for increased projection. It offers two different sounds in one instrument.

Material Rattan with coconut bottom



GANZAS

MEINL Ganzas are available in two sizes and are woven by hand with a coconut bottom. They offer a great alternative to conventional shakers.

Sizes Medium
Large
Material Rattan with coconut bottom



CAXIXIS

The MEINL Caxixis are available in three different sizes for an enhanced tonal range and woven by hand with a coconut bottom. Their sound is crystal clear, high pitched with a great projection.

Sizes Small
Medium
Large
Material Rattan with coconut bottom



ALUMINUM SHAKERS, OCTAGONAL

MEINL's Octagonal Aluminum Shakers come in three different sizes. All of them have a broad dynamic range with lots of volume.

Sizes Small
Medium
Large
Material Aluminum
Colour BK = Black



ALUMINUM SHAKER, ROUND

The MEINL Round Aluminum Shaker was designed to cut through loud live music. It has a distinctive sound with a great tonal range.

Size Large
Material Aluminum
Colour BK = Black



STUDIO SHAKER

MEINL's Studio Shaker was designed to meet all the requirements necessary in today's session world. It is light weight and therefore very comfortable to play. It delivers a very tasteful and delicate shaker sound with a warm overall tone and a very well balanced frequency spectrum.

Size Large
Material Plastic
Colour BK = Black



FIBERGLASS SHAKERS

These MEINL Shakers are made from premium fiberglass for more durability and better sound quality. They are light weight and very comfortable to play.

Sizes Medium
Large
Material Premium fiberglass
Colour BK = Black

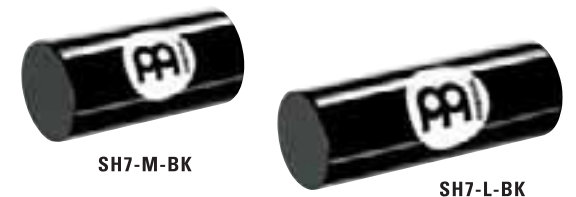

SKIN SHAKERS

The MEINL Skin Shakers combine two different materials into one unique instrument. They produce very experimental sounds and work perfectly in modern music productions.

Sizes Small
Medium
Material Plastic with natural skin side caps
Colour BK = Black



MARACAS, CAXIXIS, GANZAS, SHAKERS

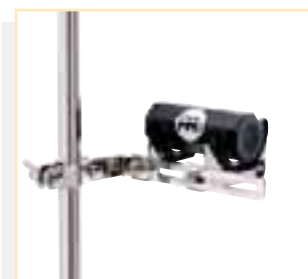

The new MEINL Shaker Holder holds any size shaker comfortably in place when it is not played. It's right there when you need it! See page 84



A DAY ON THE ROAD WITH RAY YSLAS
Christina Aguilera 'Stripped' Worldtour 2003
October 17, 2003 / Frankfurt Germany

SAMBA SERIES

The MEINL Samba Series is a line of innovative Brazilian Percussion Instruments. Its variety of different and authentic sounds combined with light weights for comfortable playing makes this series invaluable to all percussionists.

REPINIQUE

The Repinique is played with a stick while the other hand is used for open tones and slaps.

- Size** 12" x 12"
- Material** Aluminum
- Features** Counter sunk bolt heads
Chrome plated hardware
Replaceable synthetic heads
- Includes** Tuning key



Counter sunk bolt heads



RE12

SURDO

The deep sound of the Surdo is the heartbeat of Samba Music. It is played with a felt beater.

- Size** 20" x 24"
- Material** Aluminum
- Features** Counter sunk bolt heads
Chrome plated hardware
Replaceable synthetic heads
- Includes** Tuning key



SU20

PANDEIROS

The Pandeiro is played with one hand while the other alters the pitch of the drum. Solid jingles produce a brilliant and cutting sound.

- Sizes** 10"
12"
- Material** Rubber wood (*Hevea brasiliensis* Muell.-Arg.)
- Features** Counter sunk bolt lugs
Chrome plated hardware
Replaceable hand selected goat heads
- Includes** Tuning key
- Colour** CN = Chest Nut
- Finish** Hi Gloss



PA10CN

PA12CN

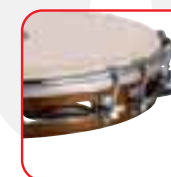

Solid jingles produce a brilliant and cutting sound

FLOATUNE® TAMBORIMS (patented)

The Tamborims are played with a plastic stick while the other hand changes the pitch of the drum. It has a bright, loud, and cutting sound.

- Size** 6"
- Material** ABS
Aluminum
Chrome plated steel
Rubber Wood (*Hevea brasiliensis* Muell.-Arg.)
- Features** Patented Floatune® Tuning System
Counter sunk bolt lugs
Replaceable synthetic heads
- Includes** German "Pfennig" as tuning key



TBR06ALU

TBR06SNT-M

TBR06ABS

TBR06CH



Patented Floatune® Tuning System

TAMBORIM STICKS

- Material** Plastic
- Colours** BK = Black
R = Red

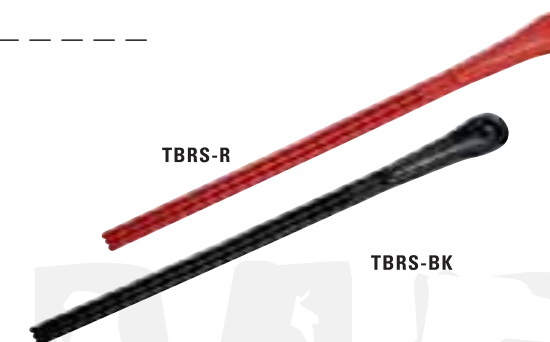

TBRs-R

TBRs-BK

IBO DRUMS

The MEINL Ibo Drums perfectly combine tradition with modern innovation. "Ibo" is the Nigerian name for "pottery" where these unique drums originate. They all have a wide spectrum of sounds, are easy to play and offer many great features.

FIBERGLASS IBO DRUMS

The MEINL Fiberglass Ibo Drums have a wide variety of different sounds and the fiberglass body make them nearly unbreakable.

- Sizes** Large
- Material** Premium fiberglass
- Features** Built in microphone hole
Resistant shell construction
- Includes** Foam padded base
- Colours** BKO = Black Ornament
BKR = Black / Red
HC = Honeycomb



FIBERGLASS TRI SOUND IBO DRUM

The MEINL Tri Sound Ibo Drum features an additional rawhide playing surface and an extra thin bottom for enhanced sound.

- Size** Large
- Material** Premium fiberglass
- Features** Rawhide playing surface
Built in microphone hole
Resistant shell construction
- Includes** Foam padded base
- Colour** GO = Gold Ornament



Extra thin bottom for enhanced sound



FIBERGLASS TRI SOUND IBO DRUM

The MEINL Tri Sound Ibo Drum features an additional fiberglass playing surface and an extra thin bottom for enhanced sound.

- Size** Large
- Material** Premium fiberglass
- Features** Extra fiberglass playing surface
Built in microphone hole
Resistant shell construction
- Includes** Foam padded base
- Colour** BKO = Black Ornament



Extra thin bottom for enhanced sound



FIBERGLASS IBO DRUM, MINI

This MEINL Fiberglass Ibo Drum is smaller sized and offers a variety of effect sounds.

- Size** Mini
- Material** Premium fiberglass
- Features** Smaller sized
Built in microphone hole
Resistant shell construction
- Includes** Foam padded base
- Colour** BKO = Black Ornament



WOOD IBO DRUM

This unique instrument is another true MEINL innovation. It features a wooden body for a wide sonic range.

- Size** Large
- Material** Made from Mango Wood (*Mangifera Sp.L.*)
- Features** Dry tones
Built in microphone hole
Resistant shell construction
- Includes** Foam padded base



Made from Mango Wood (*Mangifera Sp.L.*)

CERAMIC IBO DRUM

The ceramic body of this Ibo Drum causes a slight enhancement of the higher frequencies, with fat and powerful bass tones.

- Size** Large
- Material** Ceramic
- Features** Full and rich sounds
Built in microphone hole
- Includes** Foam padded base
- Colour** RB = Red/Brown

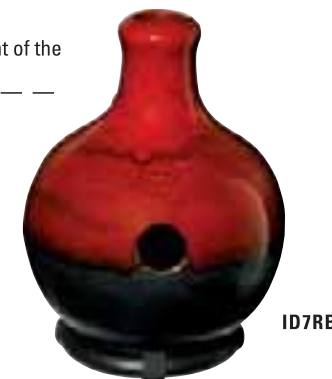

CERAMIC IBO DRUM

The special feature of this MEINL Ceramic Ibo Drum is the fiberglass bottom for extra sound options.

- Size** Large
- Material** Ceramic
- Features** Fiberglass playing surface
Built in microphone hole
- Includes** Foam padded base
- Colour** RB = Red/Brown



Extra fiberglass bottom for more sound options



Roland Peil, Germany (Fanta 4):
"Throughout my career I have broken countless clay drums. MEINL's idea of making a fiberglass body revolutionized everything. Ever since I have not broken another Ibo Drum."

IBO DRUMS



The MEINL Ibo Bags provide a dependable and hassle free transportation of the instrument. (Page 92)

RITUAL DRUMS

MEINL combines traditional instruments with modern technology and innovations. The range of Ritual Drums is a line of innovative instruments which originate in many different cultures from all around the world. MEINL's expertise in R&D helped in creating these authentic and high quality range of instruments which is outstanding in the percussion world.



The MEINL Cajon Bag ensures a secure and hassle free transportation of this most valuable instrument. See page 92

CAJON

The MEINL Cajon is completely hand made from start to finish. It combines features which up to now have never been utilized in any other cajon, like adjustable snare wires. It works perfectly for Flamenco or World Music and delivers an extremely wide range of sounds reaching from loud, deep bass tones up to cutting overtones with an abundance of projection and enforcement. Both percussionists and drummers appreciate the Cajon for its sound diversity. It also works perfectly during unplugged gigs or sessions.

- Material** Front- and backplate: American White Ash (*Fraxinus americana* L.)
Resonating body: Rubber Wood (*Hevea brasiliensis* Muell.-Arg.)
- Features** Internal, adjustable snare wires
Padded sitting surface



Fully adjustable snare wires

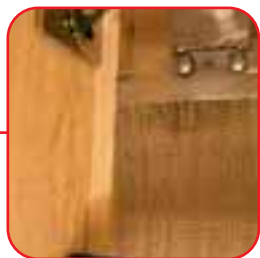

Internal snare wires



CAJ1

TAMBORA

The rhythm of the Merengue has its roots in the Dominican Republic where the use of a Tambora drum is essential in creating this style of music. It is traditionally played with the drum sitting on the lap, and struck with a beater on one side, and the bare hand on the other side of the drum.

- Size** 11"
- Material** Rubber Wood (*Hevea brasiliensis* Muell.-Arg.)
True Skin Buffalo Heads
Black powder coated hardware
- Includes** Nylon strap
Wooden beater
Tuning key
- Colour** AB-M = African Brown
- Finish** Matt



MTA1AB-M

BATAS

Having originated in West Africa and rooted in religious ceremonies, the Bata Drum made its way to Western civilization over 300 years ago. The largest Bata is called Iya and functions together with the medium Bata called Itotele. The performance usually includes a dual between the players where they question, fight, and answer each other in rhythmic patterns. The smallest bata drum is the Okonkolo and its task is to perform frequent rhythmic patterns during rituals. The MEINL Batas are made from premium fiberglass for more durability, lighter weight and comfortable playing.

- Sizes** Okonkolo 5 1/4" & 8"
Itotele 5 3/4" & 8 3/4"
Iya 6 3/4" & 12"
- Material** Premium fiberglass
- Features** Hand selected buffalo heads
Traditional TTR-Rim
- Includes** Nylon strap
Tuning key
- Colour** BK = Black



BA1BK

BA2BK

BA3BK

TALKING DRUM

The Talking Drum has its origin in West Africa. The traditional technique involves squeezing the tuning ropes while striking the head with a small bent wooden mallet. This causes the pitch of this extraordinary drum to vary widely and produces a unique effect.

- Size** 7 1/2"
- Material** Premium fiberglass
- Features** Durable synthetic heads
Wooden rims
Nylon tuning strap
- Includes** Curved wooden beater
- Colour** BK = Black



TD7BK

CAJON

WAH WAH TUBES

The MEINL Wah Wah Tube is a tubular effect instrument that delivers smooth, bell-like tones with an incredible sustain. By covering and uncovering the sound hole a "wah wah" effect can be achieved. An amazing effect instrument with surprising results and a lot of fun to play.

- Sizes** Small (high pitch)
Large (low pitch)
- Material** Aluminum
- Includes** Rubber mallet
- Colour** BK = Black



BERIMBAU

The MEINL Berimbau is another traditional African instrument which is very prevalent in Brazil and other countries of South America. Three parts are involved: The metal plate, the small caxixi, and the stick. When played correctly, it produces a very exotic and singing sound which is great for World Music and other modern productions.

- Material** Premium fiberglass
- Includes** Small Caxixi
Metal plate
Wooden Stick
Carrying bag
- Colour** R = Red



RAINMAKER

The MEINL Rainmaker is uniquely different. Due to the circular construction, it can be mounted on a cymbal stand and by simply turning the instrument a drizzle can immediately change into the sound of a monsoon. The major advantage over other rainmakers is that the sound can be continuous without changes in intensity.

- Material** Premium fiberglass
- Features** Circular construction
- Includes** Ergonomically shaped handle
- Colours** BK = Black
R = Red



BIRDS / WATERFALL

The MEINL Birds and Waterfall realistically imitate the sound of a flock of birds or a rippling waterfall. By using fiberglass a bright sound is produced, the dynamic range is increased and an optimum durability is realized.

- Material** Premium fiberglass
- Features** Durable cord



FLOATUNE® QWEEKA

The playful sound of the Qweeka originates in Brazil – the land of the Samba. While one hand rubs the internal bamboo shaft with a moist cloth, the other hand controls the pressure of the head thereby changing the pitch of the tone.

- Size** 8"
- Material** Premium fiberglass
- Features** Floatune® Tuning System
Hand selected goat head
- Includes** Tuning key
- Colour** R = Red



KOKIRIKO

The Kokiriko originated in Japan as a sound effect instrument. It produces a rattling effect which can be an almost silent rustling to an extremely loud chatter.

- Material** Wood
- Features** Ergonomically shaped handle
Durable cord
- Colour** AM = Amber



THE NIGHT

When playing The Night, four solid steel balls hit a cylindrical metal rod in quick succession producing the unique sound of crickets.

- Material** Solid steel balls and cylinder
- Features** Wooden body
Ergonomically shaped handle
- Colour** AM = Amber



THE ROAR

The MEINL Roar is available as a wood and as a fiberglass version. A rattling effect is achieved by striking the ball end against the palm of the hand. The wood version produces a warm crisp tone whereas the fiberglass version delivers a dryer and louder sound.

- Material** Wood or premium fiberglass
- Features** Solid construction

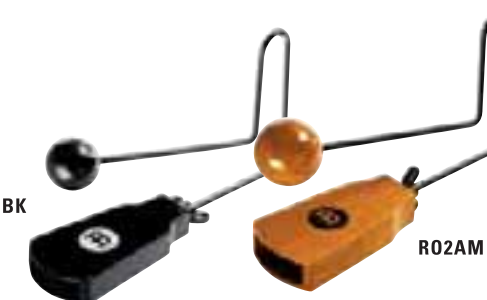

FREE RIDE SERIES (patented) MINI WOOD BONGO

The MEINL Mini Wood Bongo is a smaller version of a real sized bongo. It is equipped with professional features in miniature size just like the regular size standard model.

- Sizes** 3 1/2" Macho & 4 1/4" Hembra
- Material** Rubber Wood (*Hevea brasiliensis* Muell.-Arg.)
- Features** Free Ride Suspension System (patented)
True Skin Buffalo Heads
Rounded SSR-Rims
Chrome plated hardware
Tuning key
- Includes** Tuning key
- Colours** AB = African Brown
NT = Natural
R = Red
VSB = Vintage Sunburst
Hi Gloss
- Finish** Hi Gloss



DARBUKAS AND DOUMBEKS

Darbukas and Doumbeks have their origin in Middle Eastern music. They are very popular in countries where music and rhythm are part of daily life. Later on they found their way into Western civilization and have become a very popular instrument in today's modern music. MEINL offers a wide range of premium darbukas and doumbeks with outstanding features and sound qualities.

ALUMINUM DARBUKAS, PLAIN

These Turkish style MEINL Darbukas feature fat lows and ringing highs with a wide range between.

- Sizes** 5 1/3" x 9 1/4"
5 7/8" x 11"
7 1/4" x 13 1/3"
8" x 14 1/2"
- Material** Aluminum
- Features** Synthetic heads
- Includes** Tuning key



ALUMINUM DARBUKAS, HAND HAMMERED

These MEINL Turkish style Darbukas have a beautifully hand hammered shell. They offer resonant lows and ringing highs with a wide range between.

- Sizes** 5 7/8" x 11"
7 1/4" x 13 1/3"
8" x 14 1/2"
8" x 14 1/2" (with built in jingles)
- Material** Aluminum
- Features** Synthetic heads
Hand hammered shell
- Includes** Tuning key



COPPER DARBUKA, BRASS PLATED HAND HAMMERED

This unique instrument is made entirely of copper with a brass plated- and hand hammered shell. Strong high tones with resonant lows.

- Size** 7 1/2" x 14 3/4"
- Material** Copper
- Features** Synthetic head
Hand hammered shell
- Includes** Carrying bag
Spare head
Tuning key



COPPER DARBUKAS, HAND ENGRAVED

The beautifully hand engraved shell of this copper darbuka is outstanding in sound and look!

- Sizes** 7 1/2" x 14 3/4"
7 7/8" x 15 1/2"
- Material** Copper
- Features** Natural rawhide
Hand engraved shells
- Includes** Carrying bag
Spare head
Tuning key



ALUMINUM DOUMBEKS

Hand made entirely of aluminum, the MEINL Doumbek is outstanding in sound and quality reaching from resonant lows to ringing highs. Available as black vinyl covered or copper finished versions.

- Size** 8 1/2" x 17 1/8"
- Material** Aluminum
- Features** Synthetic heads
- Includes** Carrying bag
Spare head
Tuning key



ALUMINUM DOUMBEK, HAND HAMMERED

The aluminum shell of this MEINL Doumbek is completely hand hammered for a most appealing look.

- Size** 8 1/2" x 17 1/8"
- Material** Aluminum
- Features** Synthetic head
Hand hammered shell
- Includes** Carrying bag
Spare head
Tuning key



COPPER DOUMBEK, HAND ENGRAVED

The copper shell of this MEINL Doumbek is hand engraved for a stunning look. A very traditionally looking and sounding instrument.

- Size** 8 1/2" x 17 1/8"
- Material** Copper
- Features** Synthetic head
Hand engraved shell
- Includes** Carrying bag
Spare head
Tuning key





CANDELA® PERCUSSION CYMBALS

Drummers and percussionists often have a completely different approach to cymbal sounds. The MEINL Candela® Series of Percussion Cymbals has been designed to specifically meet the requirements of today's percussionists. All Candela® Cymbals are very thin and produce a soft and exotic sounding tone. When played by hand they exhibit a dynamic sound potential whereas when hit with a timbale stick they create a voluminous and rich sound. They are tonally matched and respond even at lower volumes.



The MEINL Cymbal Holder and Cymbal Stacker are ideal to include cymbals into any percussion set up. See page 82.

PERCUSSION SPLASH

The Candela® Series Percussion Splash is a very thin, quick sounding cymbal. It is perfect for fast percussive accents.

- Size** 10"
- Material** B20 Bronze
- Features** Hand hammered
Brilliant finish
Fast response and attack
Quick decay



CA10S

PERCUSSION CRASHES

The Candela® Series Percussion Crashes are thin, tonally matched cymbals. They can be played by hand or hit with a stick. They have a fast response and attack along with a quick decay.

- Sizes** 14"
16"
- Material** B20 Bronze
- Features** Hand hammered
Brilliant finish
Fast response and attack
Quick decay

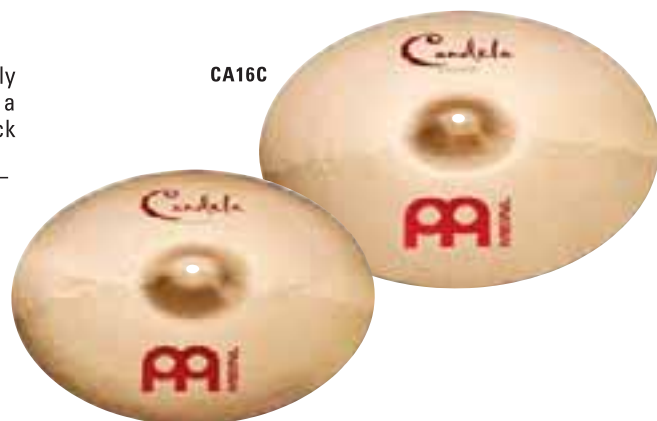

CA16C

CA14C

TIMBALE CRASH/RIDE

The Candela® Series Timbale Crash/Ride is the perfect cymbal for timbale playing. It has a loud and penetrating bell along with a full and warm sound when played as a crash.

- Size** 18"
- Material** B20 Bronze
- Features** Hand hammered
Brilliant finish
Cutting bell sound
Great crash sound



CA18CR



PERCUSSION JINGLE BELL

The Candela® Series Percussion Jingle Bell is a great effect cymbal with an exotic sound. Six pairs of jingles attached to the cymbal produce a rattling effect.

- Size** 14"
- Material** B8 Bronze
- Features** Precisely hammered
Built in jingles



CA14PJB

PERCUSSION GONGS

The MEINL Percussion Gongs create a voluminous dark sound with an extremely long sustain.

- Sizes** 20"
22"
- Material** B20 Bronze
- Features** Hand hammered
Long sustain



G22

G20

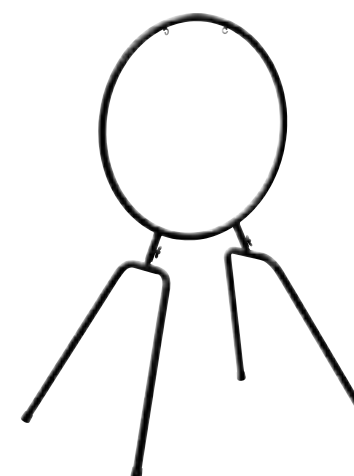

GST22

GONG STAND

The MEINL Gong Stand holds all common gongs up to 22" diameter.

- Material** Black powder coated steel
- Features** Holds gongs up to 22" diameter



ESSIEN MARK

MARK ESSIEN, GERMANY (HERBERT GRÖNEMEYER)

Originating from Ghana, Africa, Mark is a real multi-instrumentalist who besides playing percussion also plays drums, guitar, and keyboards. In 1998 Mark started to play with "Herbert Grönemeyer" and has been a member of his band ever since. In 2003 Mark was busy touring with Grönemeyer on his sold-out stadium tour "Mensch" and can be seen on homonymous DVD. Grönemeyer's latest CD "Mensch" became one of the most successful German albums ever. It sold 8x platinum in Germany, 6x platinum in Austria, and 5x platinum in Switzerland. 2004 Mark will continue the "Mensch" tour adding some spice and flavor to Grönemeyer's Rock Song and Ballads.



KENNY ARONOFF

KENNY ARONOFF, USA

Kenny is widely recognized as one of the greatest drummers in the world today. He brings tremendous drive, enthusiasm and creativity to everything he does, whether it's recording, touring, or producing and is one of the most in-demand musicians for both live performances and recording session work. He has worked live or in the studio with Bob Seger, Melissa Etheridge, The Smashing Pumpkins, Jon Bon Jovi, Elton John, Bob Dylan, John Fogerty, Joe Cocker, and many more. With a style of playing that combines power and finesse, Kenny has been named the #1 Pop/Rock Drummer and the #1 Studio Drummer for 5 consecutive years by the readers of Modern Drummer Magazine. Besides his session work in 2003 for artists like Eric Clapton, Shania Twain, Sheryl Crow, or Paul Simon, Kenny kept touring with U.S. singer Michelle Branch. 2004 kicked off with Melissa Etheridge's "Lucky Super Club Tour" and an appearance at the Jay Leno Tonight Show.

kennaronoff.com

TEENA LYLE



TEENA LYLE, ENGLAND

Throughout her career, Teena has worked/recorded (including some world-wide touring) with artists such as Bono (U2), Dodgy, Van Morrison, Steve Winwood, Candy Dulfer, Nigel Kennedy, Maceo Parker, Kim Wilde, Boy George, Paul Yong, Johnny Lee Hooker, and many others. She also acted in productions such as Walt Disney's "101 Dalmations" or "Wings of a Dove" and has appeared in various videos broadcast on MTV and VH1. All throughout 2003, Teena was on the road with the "Here & Now" Arena Tour appearing throughout Great Britain and Australia. "Here & Now" features stars and their music from the 80's, such as Go West, Kim Wilde, Paul Young and Human League. The tour will continue in 2004 throughout the USA and Australia featuring a wide array of other stars from the 80's. On top of that, Teena is gigging with her "Jazz-Hop" project in and around Monaco backing up various Hip Hop DJ's and MC's.



Eshius Mark, Netherlands (independent) · Essien Mark, Germany (Grönemeyer) · Estrada Ricardo, USA (independent) · Eto Steve, Japan (Demi Semi Quaver) · Fei Gero, Germany (Trommelpalast) · Figueroa Julio, USA (Joan Sebastian) · Fillon Antoine, Germany (independent) · Francisco Marcus, Australia (independent) · Frontera Angela, Germany (independent) · Garrido Alfonso, Germany (TV Total) · Gommeringer Mike, Germany (Reamon)

MANOLO BADRENA

MANOLO BADRENA, USA (ZAWINUL SYNDICATE)

Manolo Badrena exploded on to the world music scene with his remarkable percussion and vocal work on the outstanding 1977 release by Weather Report "Heavy Weather" (CBS Columbia CK 34418). Since then he has worked with an enormous array of artists covering a wide range of styles including jazz, latin and rock. Based out of New York City, Manolo does a lot of session work in the U.S. For most of 2003 he was out on tour with the famous Austrian musician Joe Zawinul and his Zawinul Syndicate. Manolo's plans for 2004 includes another extensive tour with Zawinul as well as finishing and releasing his solo album.



LUIS CONTE

LUIS CONTE, USA

Grammy-winner Luis Conte is an acknowledged master of percussion. His celebrated career includes touring and/or recording with some of the greatest names in contemporary music, including Madonna, Eric Clapton, Phil Collins, Santana, Celine Dion, Barbara Streisand, Backstreet Boys, Ray Charles and Cuban legends Arturo Sandoval and Chachao. He can also be heard on the scores and/or soundtracks to movies such as Mission Impossible, Rain Man, Disney's animated Tarzan, and many more. In 2003 Luis was extensively touring with legendary U.S. musician James Taylor as well as with Japanese artist Yazawa. Plans for 2004 include the Phil Collins "First Farewell Tour" along with his usual extensive amount of L.A. studio activities.

Creemers Rene, Netherlands (Drumbassadors) · Cruiks Chris, England (independent) · Da Silva Ebenezer, USA (Shakira) · Darken Eric, USA (independent) · Dauner Flo, Germany (Fanta 4) · Davis Jonathan, USA (Korn) · De Vries Wim, Netherlands (Drumbassadors) · Dely Shango, USA (Carlos Vives) · Douglas Jenny, USA (Enrique Iglesias) · Durrer Eric, Luxembourg (Eric y su Chocolate) · Dziubinski Rafal, Poland (R. Rynkowski) · Gonzales Adel, Cuba (Irakere) · Goodman Toby, England (independent) · Goumati Farouk, Germany (Bundes Jazz Orchester) · Hackett Sheryl, Germany (BAP) · Hafenstein Tanja, Australia (independent) · Hesselbach Martin, Germany (Starlight Express Musical) · Jerksen Knuth, Germany (independent) · Joris Chris, Netherlands (independent) · Kostas Gabriele, Germany (independent) · Krone Femke, Netherlands (independent) · Kutsuno Yokihide, Japan (independent) · Labarre Didier, Belgium (Cuban Breeze) · Lima Dalma, Germany (Joy Denalany) · Lingner Marcus, Germany (Jeanette) · Lockett Pete, England (independent) · Lopez Chamo, USA (Salvador) · Gonzales Adel, Cuba (Irakere)



LEA MULLEN

LEA MULLEN, ENGLAND

Lea started playing drums 15 years ago and as early as his late teens he had earned a great reputation amongst his fellow musicians in the north of England. Later on he expanded his musicality into the ever increasing world of percussion studying and mastering each instrument from congas to cowbell from timbales to triangle. Throughout his career Lea has toured or recorded with a variety of different artists, such as Happy Mondays, Buffalo 66, Oasis, Lisa Stansfield and has appeared on countless commercials and TV shows. For most of 2003 and 2004 Lea was busy touring through Japan, Korea, and Thailand with "BOND" - an all-girl string quartet. Plans for this year include the recording of the new "Wayne Edwards Project" album, followed by a UK Tour.



alex pertout

ALEX PERTOUT, AUSTRALIA

Alex is the leading percussionist in Australia. He has recorded and played with an almost endless number of artists all over the world, including The Australian Art Orchestra, Powderfinger, Nikki Webster, The Melbourne Symphony Orchestra, Christine Sullivan, and many more. His percussive work can also be heard on many soundtracks including motion pictures such as Crocodile Dundee and Siam Sunset, as well as television releases.

Alex has recently released his solo CD "From the Heart", which includes ten of his original compositions featuring masterful performances from artists such as Mike Stern, Tom Coster, Tommy Emmanuel, Raul Rekow, Hossam Ramzy, Christine Sullivan, and many more.

alexpertout.com

ROLAND PEIL

ROLAND PEIL, GERMANY (FANTA 4)

Based in Cologne, Germany, Roland is one of the most sought after percussionists in Germany. His comprehensive interest in music, adapts to any musical situation, extreme passion for percussion all stands out. He always hears what the music needs and is able to contribute to it immediately. Roland is skilled in any musical genre, whether it is Latin, Afro-Cuban, Brazilian Music, Rap, Pop, Rock, or Hip-Hop.

In 2003 Roland was busy touring and recording with German singer Sasha and Hip Hop Band Fanta 4 and for most of 2004, Roland will be on Sarah Brightman's "Harem Tour" through the USA, Canada, Asia, Australia, New Zealand and Europe.



ORIGINAL MEINL HARDWARE

A professional mounting system requires stability and flexibility. The Original Meinl Hardware features the highest quality workmanship to provide a large variety of set up solutions for both percussionist and drummers alike. A system of well thought out clamps, holders, rods, attachments, percussion tables and stands for literally any set up or space situation.

MULTI CLAMP, ONE MOUNT

The MEINL Multi Clamp easily attaches to any common stand. Its unique feature is the length adjustability to fit any given space situation. It holds one rod.

- Material** Chrome plated steel
- Features** Length adjustable
Strong mounting clamp
- Includes** Straight rod



Length adjustability for more flexibility

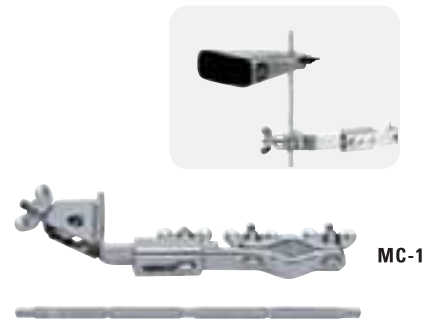

MC-1

MULTI CLAMP, TWO MOUNT

The MEINL Multi Clamp easily attaches to any common stand. Its unique feature is the length adjustability to fit any given space situation. It holds two rods.

- Material** Chrome plated steel
- Features** Length adjustable
Strong mounting clamp
- Includes** 2 straight rods

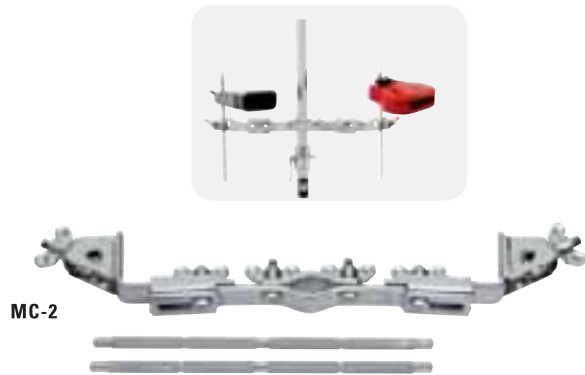

MC-2

MULTI CLAMP, FOUR MOUNT

The MEINL Multi Clamp easily attaches to any common stand. Its unique feature is the length adjustability to fit any given space situation. It holds four rods.

- Material** Chrome plated steel
- Features** Length adjustable
Strong mounting clamp
- Includes** 2 straight rods
2 angled rods



MC-4

CLAMP

The MEINL Percussion Clamp attaches to the lug of a conga, bongo, or djembe for mounting an additional cowbell, block, or tambourine.

- Material** Chrome plated steel
- Features** Compact and solid design



CLAMP

MOUNTING BAR, 6 PCS.

The MEINL Mounting Bar can easily be attached to any stand. It's ideal for expanding your percussion or drum set up.

- Material** Chrome plated steel
- Includes** 2 straight rods
2 angled rods
2 Z-shaped rods

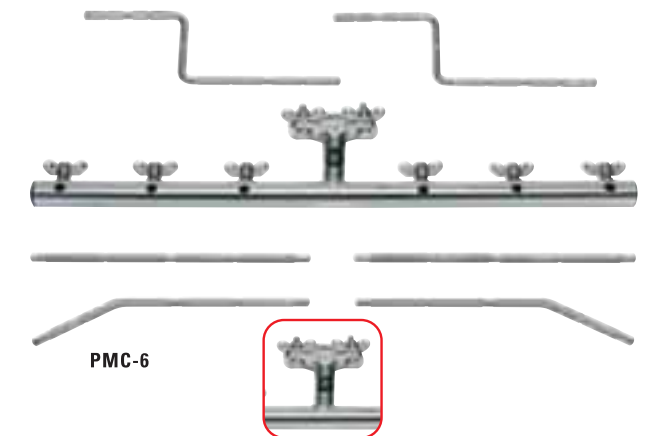
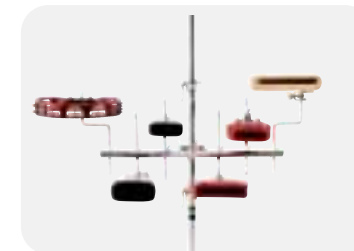

PMC-6



Strong mounting clamp

RODS

A variety of differently shaped rods can hold several mountable hand percussion instruments.

- Shape** Straight rod
Angled rod
Z-shaped rod
- Material** Chrome plated steel
- Features** Knurled surface

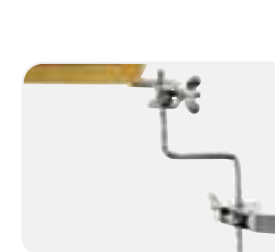

MC-R1



MC-R2



MC-R3



CHIMES HOLDERS

These two differently sized MEINL holders comfortably place the chimes within a drum or percussion set up.

- Sizes** Regular
Large
- Material** Chrome plated steel
- Features** Knurled surface
Foam washer



CYMBAL HOLDER

This MEINL holder comfortably places any cymbal within a drum or percussion set up.

- Material** Chrome plated steel
- Features** Knurled surface
Felt washers



CYMBAL STACKERS

The MEINL Cymbal Stackers enable a space saving set up of various cymbals on top of each other.

- Sizes** ø 6 mm
ø 8 mm
- Material** Chrome plated steel
- Features** Felt washers



CABASA HOLDER

This unique attachment holds the cabasa safe and ready to use. The padded surface prevents it from slipping.

- Material** Chrome plated steel
- Features** Strong mounting clamp
Padded surface

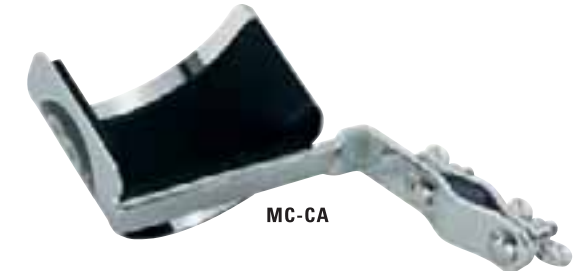

COWBELL BASS DRUM HOLDER

The MEINL Cowbell Holder attaches firmly to the bass drum hoop. Rubber pads prevent scratches on the hoop.

- Material** Chrome plated steel
- Features** Fully adjustable
Rubber pads against scratching
- Includes** L-shaped rod

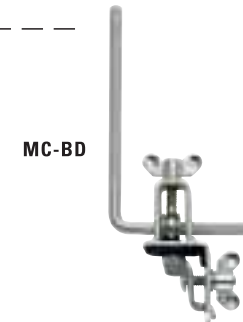

GUIRO HOLDER

The MEINL Guiro Holder firmly attaches to any common rod and holds the guiro securely in place while it is played.

- Material** Chrome plated steel
- Features** Rubber pads against scratching

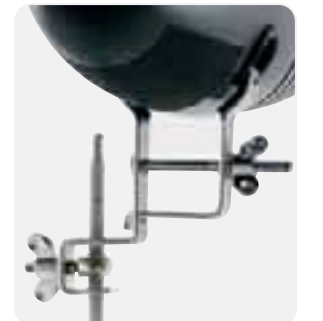
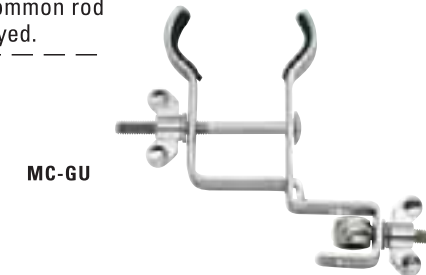

TRIANGLE HOLDER

The MEINL Triangle Holder is a simple but effective way to place the triangle in the percussion set up.

- Material** Chrome plated steel
- Features** Knurled surface
Nylon cord

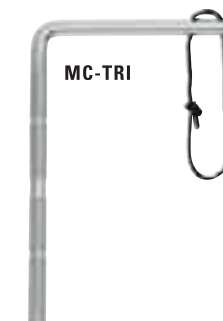



SHAKER HOLDER

The MEINL Shaker Holder (designed by Jen Lowe) firmly attaches to any common rod. With its length adjustable specially shaped claws it holds any size shaker in a comfortable position for quick reach.

- Material** Chrome plated steel
- Features** Rubber pads against scratching
Length adjustable
Strong mounting clamp



MC-SH

TAMBOURINE HOLDER

The tambourine holder converts a MEINL Hand Held Tambourine into a set up tambourine. It holds it in place and is made to resist even the hardest hits.

- Material** Chrome plated steel
- Features** Rubber pads against scratching



MC-TH

DRUMSTICK HOLDER

The MEINL Drumstick Holder firmly attaches to any common stand and stores a number of drumsticks, mallets, brushes and other accessories in its roomy pouch for ready access when needed.

- Material** Chrome plated steel
Black textile pouch
- Features** Strong mounting clamp



MC-DSH

WOOD BLOCK HOLDER

A special holder is available to include the MEINL Wood Blocks into any drum- or percussion set up. It can be fixed to any common L-rod.

- Material** Chrome plated steel



MWBH1

PERCUSSION TABLES

The MEINL Percussion Tables are made from durable fiberglass and offer enough room for all common hand percussion instruments. It can be attached to all common stands. Through its innovative design the angle of the table can be adjusted.

- Sizes** 18" x 12"
12" x 12"
- Material** Premium fiberglass
- Features** Carpeted anti slipping surface
Adjustable angle
Strong mounting clamp



MC-PTS

MC-PT

Multi adjustable

PEDAL MOUNT

The MEINL Pedal Mount fits on all common bass drum pedals and firmly holds cowbells, blocks, or tambourines. It is height adjustable and contains metal spikes attached to the bottom of the legs, holding the entire unit in place without movement.

- Material** Black powder coated steel
- Features** Height adjustable legs
Metal spikes attached to the bottom of the legs
- Includes** 2 differently sized L-rods

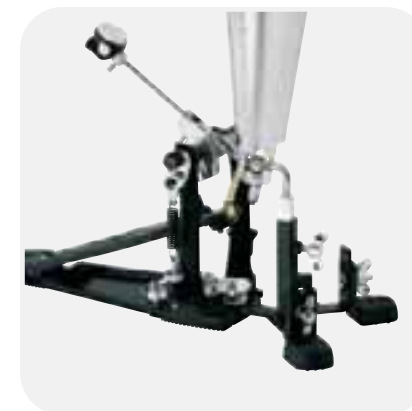

PM-1

PROFESSIONAL STANDS

MEINL offers a complete range of professional stands for congas, bongos, djembes, and hand percussion. All of them are highly innovative and feature many new developments, indicative of MEINL's leading R&D activities in this field.

PROFESSIONAL CONGA STAND (patented)

The patented MEINL Conga Stand is unique with respect to design and function.

It was especially developed to accommodate the rigors of professional road use where fine adjustment and durability are demanded. It is fully height adjustable and securely fixed by means of the three legs of the stand.

- Material** Chrome plated steel
Features Patented design
 Rubber padded crossbeams
 Fully height adjustable
 Folds up to a compact unit
Includes Allen wrench
 Memory locks



The lightweight stand can be folded to a compact unit which requires little space



TMC-CH

PROFESSIONAL BONGO STAND (patented)

The patented MEINL Bongo Stand features a new design concept and simple functionality.

The bongo is placed on a padded T-shaped tube and secured with a convenient knob screw. A stable metal clamp holds the entire unit securely in place.

- Material** Chrome plated steel
Features Patented design
 Padded "T" shaped tube
 Fully height- and angle adjustable
 Double braced tripod legs
 Fits all common bongos
Includes Allen wrench
 Memory locks



A stable metal clamp holds the entire unit in place



TMB

PROFESSIONAL DJEMBE STAND

The MEINL Djembe Stand was designed to firmly hold any djembe in the traditional playing position. A resistant nylon strap is placed around the drum and two rubber padded "U" shaped hooks are slide into the bottom of the shell. It can be angled and is fully height adjustable.

- Material** Chrome plated steel
Features Rubber padded hooks
 Fully height- and angle adjustable
 Double braced tripod legs
Includes Allen wrench
 Memory lock



TMD



Length adjustable for various djembe sizes

PERCUSSION STAND

The MEINL Percussion Stand is a universal device which offers a variety of set up solutions for both drummers and percussionists. It is fully height adjustable and features both quick locks and memory locks for a quick set up.

- Material** Chrome plated steel
Features Height adjustable
 Double braced tripod legs
Includes Allen wrench
 Memory locks
 2 straight rods
 2 angled rods
 2 Z-shaped rods

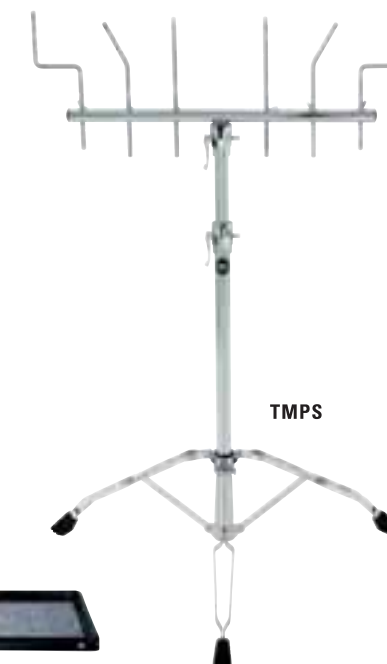

TMPS

PERCUSSION TABLE STAND

The MEINL Percussion Table Stand offers enough room for all common hand percussion instruments. It is fully height adjustable and has a carpeted anti slipping surface.

- Size** 16" x 22"
Material Table: Premium fiberglass
 Stand: Chrome plated steel
Features Carpeted anti slipping surface
 Fully height adjustable
 Double braced tripod legs
Includes Allen wrench
 Memory lock



All MEINL Tripod Stands are equipped with memory- and quick locks

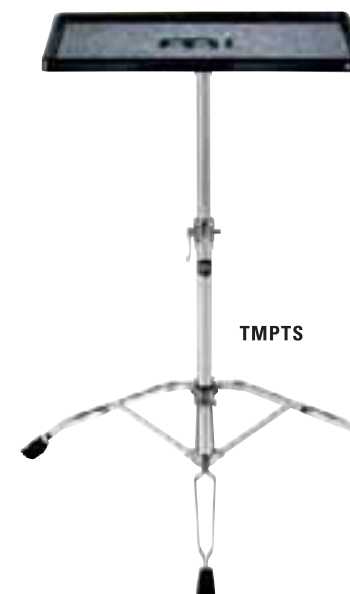

TMPTS

PROFESSIONAL STANDS





STEELY II CONGA STANDS (patented)

The MEINL Steely II Conga Stands (patented) incorporate several revolutionary and patented new designs. It features 90° angled legs for more stability. A metal spike attached to the bottom of every leg holds the stand in place and prevents movement. A U-shaped notch built in the ring of the stand allows a very quick set up and breakdown. Moreover, the stand is fully height adjustable and available for all MEINL Professional Range Congas.

- Material** Steel
- Features** Patented designs
Metal spike attached to each leg
L-shaped legs
U-shaped notch for quick set up and breakdown
Fully height adjustable
- Includes** Allen wrench



Original MEINL innovation: Height adjustability

L-shaped legs and metal spike attachments (patented)

Easy set up system (patent pending)

MODELS:

For MARATHON® Classic Series Congas

ST-MCC11BK	11"	Black powder coated
ST-MCC1134BK	11 3/4"	Black powder coated
ST-MCC1212BK	12 1/2"	Black powder coated

For MARATHON® Exclusive Series Congas

ST-MEC11CH	11"	Chrome plated
ST-MEC1134CH	11 3/4"	Chrome plated
ST-MEC1212CH	12 1/2"	Chrome plated

For MEINL Floatune® Series Congas

ST-FL10CH	10"	Chrome plated
ST-FL11CH	11"	Chrome plated
ST-FL12CH	12"	Chrome plated
ST-FL13CH	13"	Chrome plated

For MEINL Professional Series Congas

For MEINL Fibercraft® Series Congas

ST-MP11CH	11"	Chrome plated
ST-MP1134CH	11 3/4"	Chrome plated
ST-MP1212CH	12 1/2"	Chrome plated

For MEINL Artist Series Congas

ST-MSA11G	11"	Gold tone
ST-MSA1134G	11 3/4"	Gold tone
ST-MSA1212G	12 1/2"	Gold tone

For MEINL Woodcraft® Series Congas

ST-WC11CH	11"	Chrome plated
ST-WC1134CH	11 3/4"	Chrome plated
ST-WC1212CH	12 1/2"	Chrome plated



STEELY II DJEMBE STAND (patented)

The new Steely II Djembe stand (patented) features all of the same designs known from the Steely II Conga stands (patented). It can be adjusted to various djembe sizes using three spacers and is fully height adjustable. Perfect for drum circles and other street percussion activities.

- Material** Chrome plated steel
- Features** Patented designs
Metal spike attached to each leg
L-shaped legs
U-shaped notch for quick set up and breakdown
Fully height adjustable
Adapts to different djembe sizes
- Includes** Allen wrench
3 spacers

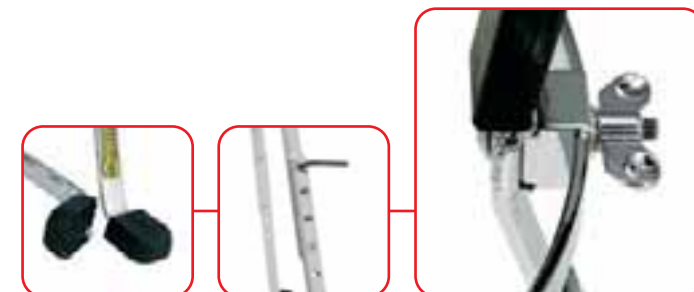

L-shaped legs with metal spike attachments (patented)

Original MEINL innovation: Height adjustability

3 spacers to fit various djembe sizes



ST-DJEMBE

TIMBALE STAND

This timbale stand holds any MEINL Timbale Set and is available individually.

- Material** Chrome plated steel
- Features** Fully height adjustable
Double braced tripod legs
- Includes** Allen wrench
Memory lock
Cowbell holder



TMT

PROFESSIONAL BAGS

MEINL has developed a line of bags to provide your instrument with dependable protection, making transporting as hassle free as possible. They are made from heavy-duty padded nylon with reinforced stitching and are equipped with a double-slide zipper, adjustable and comfortable shoulder straps, and padded carrying grips.

CONGA BAGS

The MEINL Conga Bags come in three sizes: Quinto, Conga, and Tumba. An additional upright zipper simplifies packing and unpacking of your drum. Additional features are padded backpack straps and an external pocket for accessories.

- Sizes** 11"
11 3/4"
12 1/2"
- Material** Heavy duty padded nylon
- Features** Additional upright zipper
External pocket
Padded backpack straps
Carrying grip



MCOB-11

MCOB-1134

MCOB-1212

DJEMBE BAGS

The MEINL Djembe Bags come in two sizes medium and large to fit all common djembe models. Additional features are padded backpack straps and an external pocket for accessories.

- Sizes** Medium (up to 12")
Large (up to 13 1/2")
- Material** Heavy duty padded nylon
- Features** External pocket
Padded backpack straps
Carrying grip



MDJB-M

MDJB-L

TIMBALE BAG

The MEINL Timbale Bag has two internal compartments (padded separator included) to fit both timbale drums (up to 15") and an outside pocket to fit the stand, cowbells, and sticks.

- Material** Heavy duty padded nylon
- Features** External pocket for stand and cowbell
Padded shoulder strap
Carrying grip
Padded separator



MTB

BONGO BAG

The MEINL Bongo Bag fits all common bongo models and still has enough room for some hand percussion instruments. A padded separator is included.

- Material** Heavy duty padded nylon
- Features** Additional room for accessories
Padded shoulder strap
Carrying grip
Padded separator



MBB

CAJON BAG

The MEINL Cajon Bag is the perfect solution for transporting these valuable and fragile instruments. Its heavy duty padded outside walls store it securely and prevents damage.

- Material** Heavy duty padded nylon
- Measures** 20 1/2" W x 12" H x 12" D
- Includes** Padded shoulder strap
Carrying grip



MCJB

IBO BAGS

The MEINL Ibo Bag fits all common clay drum models and is the perfect solution for transporting these valuable and fragile instruments. Its heavy duty padded outside walls store it securely and prevents damage.

- Sizes** Small (9 3/4" W x 13 1/3" H x 9 3/4" D)
Medium (11" W x 14 1/2" H x 11" D)
- Material** Heavy duty padded nylon
- Includes** Padded shoulder strap
Carrying grip
External pocket



MIB-M



MIB-S



The MEINL Ibo Bags perfectly protect these fragile and valuable instruments during transportation.

CHIMES BAG

The MEINL Chimes Bag fits all common chime models and is the perfect solution for transporting these valuable and fragile instruments. Inner velcro straps hold the instrument in place while two internal pockets secure them.

- Material** Heavy duty padded nylon
- Features** Stores up to 2 chimes
- Includes** Carrying grip
Inner velcro straps
2 internal pockets



MCHB



2 internal pockets with inner velcro straps

STICK BAG

The MEINL Stick Bag offers four spacious sections for drumsticks and a separate compartment for drum keys, small tools and other valuables.

- Material** Heavy duty padded nylon
- Features** External pocket
Shoulder strap
Extension straps



MSB-1



Spacious stick compartments for quick access

CYMBAL BAG

The MEINL Cymbal Bag holds cymbals up to 22" diameter. An external compartment which holds cymbals up to 14" allows a comfortable weight balance when packed.

- Size** 22"
- Material** Heavy duty padded nylon
- Features** External compartment
Padded dividing pads
Padded shoulder strap
Carrying grip

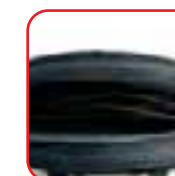

Individual compartments prevent from direct metal to metal contact



MCB22

RAY YSLAS



RAY YSLAS, USA (CHRISTINA AGUILERA)
 This internationally known percussionist, a Mexican-American of Los Angeles, has been keeping very busy these past few years. He was nominated Percussionist of the Year, has performed on most award shows with many different artists, performed on the title song of the award winning show "Sex and the City", and has toured with major artists in both the American and Latin music scene. In January of 2002, he finished a fourteenth month world tour with the Backstreet Boys. In April of 2002, he began performing with Patti Labelle, and still does the gig once in a while. While all of this was going on, he began to work with Christina Aguilera in October 2002. The promotional tour took him to the Bahamas, New York, Mexico, California, Louisiana, and other places. Now, he joins Christina Aguilera's "Stripped Tour" beginning this summer which will keep him busy until the end of 2004 touring all over the world



RUSS MILLER, USA (INDEPENDENT)
 Russ spent the last half of 2003 and the beginning of 2004 in the studio. The latest released hit albums include: Hilary Duff's "Metamorphosis" album 3x platinum!, Nelly Furtado's "Folklore" Gold in one week! and Bobby Caldwell's latest album "Lifeline". Recordings that Russ has been working on include: Cher's new album "Turn To Stone", Canadian star "Jarvis Church", Resident Evil "Apocalypse" movie Soundtrack, "Garfield" movie soundtrack and the new power trio "Powernut" featuring Russ, Vail Johnson and Tommy V. Russ will be touring with Bobby Caldwell this summer and back with Jennifer Love-Hewitt after a break for her movie career. Russ will be a featured artist at the Frankfurt Messe in March, a 11 country South American clinic tour and the Bavarian Music Academy "Rhythm" course in Germany. He also has his Drum Set Crash Course Tuning Edition video being released on DVD from Warner

ORESTES VILATO, USA
 Orestes Vilato has been referred to as the "Cuban multi-percussionist extraordinaire". He is without a doubt one of the greatest figures in the history of the Timbales. From 1980 to 1989, Orestes recorded and performed with the renowned Carlos Santana band. He recorded over 300 albums with various artists including Ray Barretto, Cachao, Aretha Franklin, Patato Valdez, Herbie Hancock, Rebeca Mauleon, Buddy Montgomery, and many more.



Lowe Jen, USA (Acres) · Lyle Teena, England (independent) · Maass Stephan, Austria (Reinhard Fendrich) · Maldonado Carlos, Puerto Rico (independent) · Persson Magnus, Sweden Mancuso Steve, Canada (independent) 9 Manoilovich Vancho, England (Roberto Pla Latin Ensemble) · Martinez Pau, Spain (independent) · Melian Juan Carlos, Spain (independent) · Mendosa Renis, Germany (Modern Talking) Miller Russ, USA (independent) · Mullen Lea, England (independent) · Naruse Yoshihiro, Japan (Casiopea) · Nuzzoli Gabriel, England (independent) · Oviedo Calixto, Cuba (independent) · Padron Flaco, USA (independent) · Patterson Chris, USA (Super Action Heroes) · Peil Roland, Germany (Fanta 4, Sascha) · Persson Magnus, Sweden (Elvis Costello) · Lowe Jen, USA (Acres) · Padron Flaco, USA (independent)

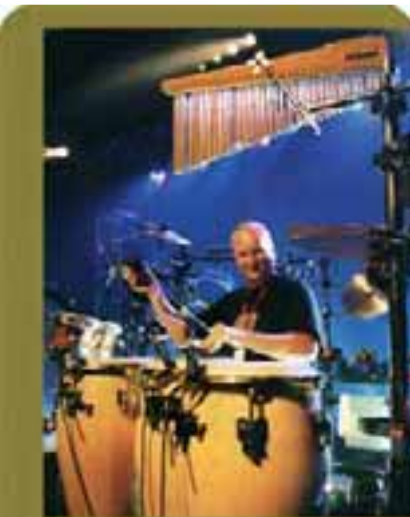

STEPHAN MAASS

STEPHAN MAASS, AUSTRIA (REINHARD FENDRICH)
 Based in Vienna since 1993, Stephan has made a huge name for himself in the European percussion scene. His tasteful playing and creative approach on any musical situation can be heard on more than 400 albums, all of which he has been a part of. Names like Randy Brecker, Harold Faltermayer, Count Basie, Wolfgang Ambros, Kruder & Dorfmeister, Idris Muhammad, NDR Bigband, Konrad Schrenk's Extravaganze, Reinhard Fendrich, Konstantin Wecker, and many more have relied on Stephan's musicality live and in the studio. 2004 will keep Stephan busy teaching percussion and rhythm at the Bruckner-University in Linz, Austria. Starting in September 2004 Stephan will again be on tour with the famous Austrian singer Reinhard Fendrich. www.stephanmaass.com



Jen Lowe, USA (Acres)
 Jen Lowe is not just another musician. Jen is a beautiful, sexy punk-hip-hop-folkie rocker whose dynamic is felt no matter what project she is involved in, whether live onstage or in the studio. Having been compared to artists such as Sheila E. for her precise and dynamic musicianship, Jen has something to offer musically that is the perfect recipe of melody, rhythm and emotion to any modern recording, live band, or acoustic singer/songwriter. Although she is currently best known for her collaboration in the popular rock band, ACRES, she has also recorded drums/percussion on over 50 albums, written, co-written and produced songs, and toured nationally sharing stages with artists such as Ritchie Havens, Sister Hazel, Angie Aparo, Gib Droll, The Pat Mcgee Band, and many more. A genuinely twist and one of today's most talented percussionists
jenlowe.com

Vacik Milos, Czech Rep. (Tam Tam Orchestra) · Valdès Amadito, Cuba (Buena Vista Social Club) · van Stratum Ron, Netherlands (independent) · Vieten Sabine, Germany (Die Happy) · Vilato Orestes, USA (independent) · Wackerman Chad, Australia (Alan Holdsworth) · Waronker Joey, USA (independent) · Waschinger Tomàs, Czech Rep. (Petr Muk Band) · Wertico Paul, USA (Pat Metheny) · Yahiro Tomohiro, Japan (independent) · Yslas Ray, USA (Christina Aguilera) · Z. Nir, USA (Genesis)

Pertout Alex, Australia (independent) · Phillips Simon, USA (Toto) · Phillips Omar, USA (independent) · Pina Fernando, USA (independent) · Quintero Nene, Venezuela (independent) · Rada Ruben, Uruguay (independent) · Ramzy Hossam, England (Chick Corea) · Rein Florian, Germany (Bananafishbones) · Reiter Gerhard, Austria (independent) · Rodriguez Edgard, USA (Perco Loco Allstars) · Rodriguez Eduardo, USA (Gloria Estefan) · Rubow Oli, Germany (Turntablerockers) · Salesvuo Tomi, Finland (Bitter Sweet) · Santiago Louis jr., USA (independent) · Scarbi Shaddy, Italy (independent) · Schäperclaus Mike, Netherlands (Metropole Orkest) · Sendou Saoli, Japan (independent) · Solis Javier, USA (Jaci Velasquez) · Smeč Ludo, Slovakia (Misha) Strik Chris, Netherlands (independent) · Summers Bill, USA (Headhunters) · Szabados Tibor, Slovakia (Hex) · Temiz Okay, Turkey (Magnetic Band) · Tempesta John, USA (White Zombie) · Thompson Chester, USA (Phil Collins) · Torres Jose Miguel, Poland (independent) · Torres Elliot, USA (Salvador) · Tsoukas Athanasios, Germany (Al Bano, Soul Doctor) · Pertout Alex, Australia (independent)



AMADITO VALDÈS, CUBA (BUENA VISTA SOCIAL CLUB)
 Amadito Valdès "the timbal magician" was born in Havana, February 14th 1946. He studied at the Havana Conservatoire with maestros Guillermo Barreto and Alfredo de los Reyes. He is the creator of a unique style of improvisation on the timbales, which mixes Afro rhythms in 6/8 with the son syncopated rhythms in 2/4. Valdès has worked with the most important Cuban big bands since the 70's and has recorded countless albums with artists of the stature of Las D'Aide, Paquito Revera, Emiliane Salvador, Bebo Valdès, Las Estrellas de Areito and Peruchin. Since 1997, he has recorded and toured the globe with artists such as Juan do Marco and the Afro-Cuban-Allstars, Rubèn Gonzalez, Felix Baloy. He is featured in Wim Wender's famous movie Buena Vista Social Club and has also performed at the 42nd annual Grammy Awards 2000 in Los Angeles featuring Grammy Winner Ibrahim Ferrer. In 1997 he took part in what has been known as the project "Buena Vista Social Club". In 2003, Amadito's solo album "Bajando Gervasio" was nominated for a GRAMMY in the category "Best Traditional Tropical Latin Album".
amaditovaldes.com

ALFONSO GARRIDO

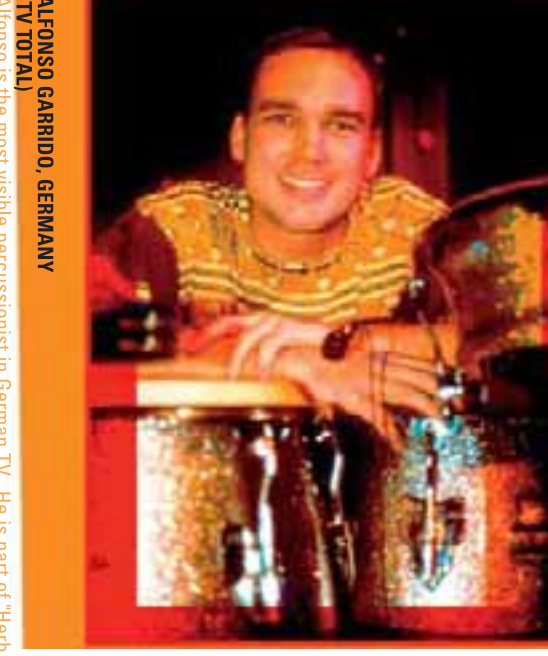

ALFONSO GARRIDO, GERMANY (TV TOTAL)
 Alfonso is the most visible percussionist in German TV. He is part of "Herb & the Heavytones" - Stefan Raab's houseband on his very famous daily comedy show "TV TOTAL" where he is seen all over Germany by millions of people every day. "Herb & the Heavytones" also back up Max, who is the winner of Stefan Raab's casting show SSSDSPS. The band is part of his video "Can't wait until tonight" which is nominated to represent Germany at the European Grand Prix Competition 2004 in Istanbul, Turkey.



EDDIE RODRIGUEZ

EDDIE RODRIGUEZ, USA (GLORIA ESTEFAN)
 Eddie Rodriguez plays with the "who is who" in Latin Pop. His musicality and tasteful playing makes him the first choice for artists such as The Miami Sound Machine and Eddie Pamieri. Currently Eddie is touring with Latin Superstar Gloria Estefan.

RÈNE CREEMERS
 Currently René is playing with the Rich Wyman Band, Kazda and MEC. He is also co-founder of The Drumbassadors, a drum duet with another Dutch Drummer Wim de Vries. As an educator, René teaches at the Arnhem Conservatory and the Tillburg Rock Academy in Holland. He also is regular guest teacher at the Drummer's Institute in Duesseldorf Germany, and the Los Angeles Music Academy (LAMA) in USA. Besides his busy teaching schedule, René has been active in 2003 touring with "The Drumbassadors" including his spectacular appearance at the 2003 Modern Drummer Festival.
renewcreemers.com



RÈNE CREEMERS, NETHERLANDS (THE DRUMBASSADORS)

Dutchman René Creemers is one of the most qualified and unique drummers in Europe. He began his career as the drummer of a Dutch group called Blowbeat who enjoyed tremendous success, particularly in the club circuit of Germany, Austria and Switzerland.



CONGAS

SERIES	SIZE	HEAD	RIM	LUG	BRACKET
HEADLINER	10"	HHEAD10	HRIM10	HCLUG	HCBRACKET-02
HEADLINER	11"	HHEAD11	HRIM11	HCLUG	HCBRACKET-02
HEADLINER	12"	HHEAD12C	HRIM12C	HCLUG	HCBRACKET-02
MCC11	11"	TS-B-38	SSR-25	LUG-03	BRACKET-15
MCC1134	11 3/4"	TS-B-39	SSR-26	LUG-03	BRACKET-15
MCC1212	12 1/2"	TS-B-40	SSR-27	LUG-03	BRACKET-15
MEC11	11"	TS-B-28	SSR-09	LUG-03	BRACKET-14
MEC1134	11 3/4"	TS-B-29	SSR-11	LUG-03	BRACKET-14
MEC1212	12 1/2"	TS-B-30	SSR-14	LUG-03	BRACKET-14
FC11	11"	TS-B-34	SSR-22	LUG-01	BRACKET-14
FC1134	11 3/4"	TS-B-35	SSR-23	LUG-01	BRACKET-14
FC1212	12 1/2"	TS-B-36	SSR-24	LUG-01	BRACKET-14
FL10	10"	TS-B-01	SSR-06	LUG-01	
FL11	11"	TS-B-03	SSR-07	LUG-01	
FL12	12"	TS-B-15	SSR-12	LUG-01	
FL13	13"	TS-B-21	SSR-15	LUG-01	
MP11	11"	TS-B-34	SSR-22	LUG-01	BRACKET-14
MP1134	11 3/4"	TS-B-35	SSR-23	LUG-01	BRACKET-14
MP1212	12 1/2"	TS-B-36	SSR-24	LUG-01	BRACKET-14
MSA11	11"	TS-B-07	SSR-08	LUG-02	BRACKET-16
MSA1134	11 3/4"	TS-B-11	SSR-10	LUG-02	BRACKET-16
MSA1212	12 1/2"	TS-B-17	SSR-13	LUG-02	BRACKET-16
WC11	11"	TS-B-44	TTR-23	LUG-01	BRACKET-14
WC1134	11 3/4"	TS-B-45	TTR-24	LUG-01	BRACKET-14
WC1212	12 1/2"	TS-B-46	TTR-25		



BONGOS

SERIES	SIZE	HEAD	RIM	LUG
HB100	6 3/4" 8"	HHEAD634W HHEAD8W	HRIM634W HRIM8W	HBLUG HBLUG
FWB100	3 1/2" 4 1/4"	TS-B-31 TS-B-32	SSR-16 SSR-17	LUG-19 LUG-19
FWB190	6 3/4" 8"	HEAD-38 HEAD-39	SSR-18 SSR-19	LUG-22 LUG-22
FWB200	6 3/4" 8"	HEAD-38 HEAD-39	SSR-20 SSR-21	LUG-22 LUG-22
FFB200	6 3/4" 8"	TS-B-50 TS-B-51	SSR-34 SSR-35	LUG-23 LUG-23
FWB400	7" 8 1/2"	TS-C-02 TS-C-03	SSR-02 SSR-04	LUG-07 LUG-07
FFB400	7" 8 1/2"	TS-C-02 TS-C-03	SSR-02 SSR-04	LUG-07 LUG-07
WB500	7" 9"	TS-C-11 TS-C-12	TTR-26 TTR-27	LUG-07 LUG-07
CS400	7" 8 1/2"	TS-C-02 TS-C-03	SSR-02 SSR-04	LUG-07 LUG-07



TIMBALES

SERIES	SIZE	HEAD	RIM	LUG	BRACKET
HT1314	13" 14"	HEAD-24 HEAD-22	RIM-37 RIM-38	LUG-26 LUG-26	BRACKET-18 BRACKET-18
MT1415	14" 15"	HEAD-22 HEAD-23	RIM-23 RIM-24	LUG-17 LUG-17	BRACKET-12 BRACKET-12
TI1BK	13" 14"	HEAD-24 HEAD-22	RIM-21 RIM-22	LUG-17 LUG-17	
AV1BK	14" 15"	HEAD-22 HEAD-23	RIM-27 RIM-28	LUG-17 LUG-17	
LC1	14" 15"	HEAD-22 HEAD-23	RIM-19 RIM-20	LUG-16 LUG-16	BRACKET-08 brass BRACKET-09 brass, small BRACKET-10 chrome, small BRACKET-11 chrome, small
BT1415	14" 15"	HEAD-22 HEAD-23	RIM-19 RIM-20	LUG-16 LUG-16	BRACKET-10 chrome BRACKET-11 chrome, small
MDT13CH	13"	HEAD-43	RIM-31	LUG-21	BRACKET-13
MIT810CH	8" 10"	HEAD-41 HEAD-42	RIM-29 RIM-30	LUG-21 LUG-21	BRACKET-13 BRACKET-13



DJEMBES

SERIES	SIZE	HEAD	RIM	LUG	BRACKET
HDJ600	12"	HHEAD12W	HRIM12W	HDLUGW	HDBRACKET-02
DJW3	12"	TS-G-01	SSR-29	LUG-04	
DJW3AWA	12"	TS-G-01	SSR-36	LUG-25	
DJF3	12"	TS-G-01	SSR-29	LUG-05	
DJW2	12 3/4"	TS-G-02	SSR-30	LUG-04	
DJW21	21"	TS-C-09	TTR-22	LUG-06	
DJWR3	12"	TS-CA-01			



DANCING DRUMS

SERIES	SIZE	HEAD	RIM	LUG	BRACKET
HC301	8 1/2"	HHEAD8,5	HRIM8,5	HDCLUG	HDBRACKET-02
HDJ400	12"	HHEAD12	HRIM12	HDLUG	HDBRACKET-02
HDJ200	8"	HHEADDJ8	HRIMDJ8	HD200LUG	
HFDD1	8 3/4"	HHEADHFDD1	HRIMHFDD1	HFDDLUG	HFDDBRACKET
HFDD2	8"	HHEADHFDD2	HRIMHFDD2	HFDDLUG	HFDDBRACKET
HFDD3	7 1/2"	HHEADHFDD3	HRIMHFDD3	HFDDLUG	HFDDBRACKET



DARBUKAS/DOUMBEEKS

SERIES	SIZE	HEAD	FOR MODEL NO.
Plastic Heads	5 1/3"	HE-HEAD-100	HE-100
	5 7/8"	HE-HEAD-101	HE-101 / HE-111
	7 1/4"	HE-HEAD-103	HE-103 / HE-113
	7 1/2"	HE-HEAD-214	HE-214
	8"	HE-HEAD-104	HE-104 / HE-114 / HE-314 / HE-4002
	8 1/2"	HE-HEAD-3000	HE-3000 / HE-3012 / HE-3020 / HE-3030
Natural Heads	7 1/2"	HE-HEAD-204	HE-204
	7 7/8"	HE-HEAD-205	HE-205



SPARE PARTS FOR STANDS

Cowbell Holder, complete for Meinl Timbales	STAND-01
Cowbell Holder, complete for HT1314 Timbales	HDSTAND-01
L-Shaped Clamp for top part for TMB	STAND-18
Fast Lock Set, chrome	STAND-14
Fast Lock Set, black	STAND-15
Memory Clamp, chrome, for upper stand tube	STAND-11
Memory Clamp, chrome, for middle stand tube	STAND-07
Memory Clamp, black, for middle stand tube	STAND-08
Memory Clamp, chrome, for lower stand tube	STAND-09
Memory Clamp, black, for lower stand tube	STAND-10
Rubber Feet (set of 3pcs) for Timbales, Bongo, Djembe Stand	STAND-16
Rubber Feet (set of 3pcs) for Steely-II Stands	STAND-35
Rubber Tops (set of 3pcs.) for Steely Stands	STAND-21
Screw Set complete for Steely Stand, black	STAND-22
Screw Set complete for Steely Stand, chrome	STAND-23
Screw Set complete for Steely Stand, gold tone	STAND-24
Socket Screw (set of 2pcs.) black	STAND-26
Socket Screw (set of 2pcs.) chrome	STAND-27
Socket Screw (set of 2pcs.) gold tone	STAND-28
Upper Stand Section, complete from TMB	STAND-34



RITUAL DRUMS

SERIES	SIZE	HEAD	RIM	LUG	BRACKET
BA1	5 1/4"	HEAD-07	RIM-04	LUG-12	
	8"	HEAD-08	RIM-05	LUG-12	
BA2	5 3/4"	HEAD-09	RIM-06	LUG-12	
	8 3/4"	HEAD-10	RIM-07	LUG-12	
BA3	6 3/4"	HEAD-11	RIM-08	LUG-12	
	12"	HEAD-12	RIM-09	LUG-12	
HCG89	8"	HEAD-05	TTR-05	LUG-11	HDBRACKET-02
	9"	HEAD-06	TTR-08	LUG-11	HDBRACKET-02
MTA1	11"	TS-B-09 (NT)	RIM-03	LUG-10	BRACKET-06
	11"	TS-B-10 (WH)		LUG-10	BRACKET-06
PA10	10"	HEAD-44	RIM-33	LUG-24	BRACKET-19
PA12	12"	HEAD-45	RIM-34	LUG-24	BRACKET-19
QW7	8"	HEAD-13	RIM-10	LUG-13	
RE12	12"	HEAD-47	RIM-36	LUG-28	
SU20	20"	HEAD-46	RIM-35	LUG-27	
TBR06	6"	HEAD-40	RIM-32	LUG-20	
TD7	7 1/2"	HEAD-35	RIM-25		

OTHER PARTS

Lug Oil	SPARE-09
Tambora Beater	SPARE-01
Talking Drum Beater	SPARE-10
Chimes Beater	NINO567
Wah Wah Beater	SPARE-12
Guiro Scraper Wood (GU1)	SPARE-04
Guiro Scraper Plastic (GU6 / GU7)	SPARE-13
Cowbell Bolt, complete	SPARE-11
Chimes Holder	SPARE-07
Conga Saver for 8mm Lugs (set of 6pcs.)	CONGA-SAVER8
Conga Saver for 10mm Lugs (set of 6pcs.)	CONGA-SAVER10
Tuning Key, 13mm + 14mm, L shaped, gold tone	KEY-01
Tuning Key, 13mm + 14mm, L shaped, chrome	KEY-02
Tuning Key, 14mm, chrome	KEY-03
Tuning Key, 13mm, chrome	KEY-04
Tuning Key, 12mm + 13mm	KEY-05
Tuning Key, 10mm	KEY-06
Standard Drum Key	KEY-07





FIRST MOVE



NINO® PERCUSSION

FIRST MOVE

The new generation of musical instruments for early childhood education.

NINO® instruments meet exactly the requirements of early childhood education and are perfectly suitable for the use in kindergartens, schools, music therapy and for musical activities at home.

The easy handling and an appealing design are standard for all NINO® instruments.

They are noteworthy due to their professional features, the great sound and their outstanding quality. The strong, childproof workmanship guarantees years of trouble-free use of all NINO® instruments.



THE SAFETY

NINO® instruments have been tested by the Landesgewerbeanstalt Bayern, Germany (LGA), Institute for the Testing of Goods and Quality Monitoring and have been awarded with the LGA Test Certificate. This means that NINO® instruments comply with the strict requirements of the European Community Directives 88/378EC and 87/357/EC.

PRODUCT TESTING

All NINO® instruments are regularly tested for safety and sanitary harmlessness according to the EC Directives 88/378/EC (Toy Safety Directive) and 87/357/EC (Imitation of Food).

The tests are carried out by the Landesgewerbeanstalt Bayern, Germany (LGA), a modern testing and consulting services organization with over 30 branches worldwide.

As a recognized institute for the testing of goods and quality monitoring, the LGA is entitled to award the GS and LGA test marks which are accepted throughout Europe and internationally as a guarantee of safety.

NINO® INSTRUMENTS PASS THE FOLLOWING TESTS:

Testing in dependence on the Toy Safety Directive (88/378/EC)

Mechanical and physical characteristics

Inflammability

Migration of certain parts

Saliva and perspiration resistance

Colorfastness

Determination of the content of Pentachlorophenol (PCP)

Testing with regard to pesticides

Valuation in accordance with EC Directive 87/357/EC



Rubber Wood plantation farm in Thailand

CERTIFICATION

After passing all tests, the internationally accepted LGA Test Certificate was awarded for all NINO® percussion instruments. This certificate vouches for quality and safety.

MATERIAL & ECOLOGY

Wood is a raw material which is present in almost every part of our daily life. Trees are an important part of the complex eco-system while healthy forests are imperative for the Earth's atmosphere.

Only Rubber Wood (*Hevea brasiliensis* Muell.-Arg.) is used for the making of NINO® percussion instruments. This wood fulfils the CITES regulations ("Convention on International Trade in Endangered Species of Wild Fauna and Flora") and originates from environmentally controlled forests from industrial wood plantations.

WOOD FROM ENVIROMENTALLY CONTROLLED WOOD PLANTATIONS

Thailand is a logical manufacturing base for percussion instruments due to the fact that the Hevea Brasiliensis, which was indigenous to Brazil and later transported by way of England to Asia, has been commercially grown in Southeast Asia during the last century on plantation farms for the production of Latex.

The traditional plantation of Rubber Wood (*Hevea brasiliensis* Muell.-Arg.) meets all ecological requirements. In a natural evolution, new trees are planted and the older ones, which have ceased to provide latex, are harvested. In this way, plenty of raw material is available and the valuable rain forest eco-system is preserved.





CONGA SETS

NINO® Congas are famous for their professional workmanship. Available are fiberglass or wood sets. They all include basket stands and can therefore be played individually or in a set configuration.

NIN0910 WOOD CONGA SETS

The NIN0910 Wood Congas are ideal for first time players or schools. Height adjustable stands included.

- Size** 9" & 10"
28" tall
- Material** Rubber Wood (*Hevea brasiliensis* Muell.-Arg.)
- Features** Hand selected buffalo heads
Rounded rims for playing comfort
Black powder coated hardware
- Includes** Height adjustable basket stands with quick set up system
Tuning key
- Colours** NT = Natural
WR = Wine Red



NINO® Wood Congas are equipped with strong tuning bracket

The rounded rim offers perfect playing comfort without harming the wrist or palm

NIN089 WOOD CONGA SETS

The NIN089 Wood Congas can be played standing up or sitting down and are therefore the perfect congas for children in kindergardens.

- Size** 8" & 9"
22" tall
- Material** Rubber Wood (*Hevea brasiliensis* Muell.-Arg.)
- Features** Hand selected buffalo heads
Rounded rims for playing comfort
Black powder coated hardware
- Includes** Basket stands
Tuning key
- Colours** NT = Natural
WR = Wine Red



FIBERGLASS CONGA SETS

Our fiberglass is a high quality material, manufactured by hand, into especially powerful sounding shells. The advantage over wood congas is the lower weight which makes handling much easier. The model with its colourful Harlekin® design will certainly attract attention.

- Size** 8" & 9"
22" tall
- Material** Premium fiberglass
- Features** Hand selected buffalo heads
Rounded rims for playing comfort
Black powder coated hardware
- Includes** Basket stands
Tuning key
- Colours** HK = Harlekin
R = Red



WOOD DJEMBES



The Djembe is the most popular African drum. Even untrained players are quickly able to draw different tones from this great instrument. The NINO® Wood Djembe has a diameter of 10" and a height of 21" and is the perfect drum for children in kindergarden or elementary school.

- Size** 10" tall
- Material** Rubber Wood (*Hevea brasiliensis* Muell.-Arg.)
- Features** Hand selected goat heads
Rounded rims for playing comfort
Black powder coated hardware
Patented Floatune® Tuning System
- Includes** Tuning key
- Colours** NT = Natural
WR = Wine Red



The rounded rim offers perfect playing comfort without harming the wrist or palm

NINO® Djembes are equipped with the patented Floatune® Tuning System which avoids drilling into the shell



NIN023NT

NIN023WR

WOOD BONGOS

The NINO® Wood Bongo is an affordable yet high quality instrument with great versatility in sound. Children love the coloured Harlekin® design!

- Size** 6 1/2" & 7 1/2"
- Material** Rubber Wood (*Hevea brasiliensis* Muell.-Arg.)
- Features** Hand selected buffalo heads
Rounded rims for playing comfort
- Includes** Tuning key
- Colours** NT-HK = Natural Shell / Harlekin Hardware
NT-BK = Natural Shell / Black Hardware
WR-BK = Wine Red Shell / Black Hardware



NIN03NT-HK

NIN03WR-BK

NIN03NT-BK

ABS BONGOS PLUS

A real alternative! The NINO® ABS Bongo Plus is an affordable bongo with a great sound and functional hardware. Shells made of ABS plastic make this bongo lighter than comparable wood models.

- Size** 6 1/2" & 7 1/2"
- Material** ABS Plastic
- Features** Hand selected buffalo heads
Rounded rims for playing comfort
Black powder coated hardware
Tuning key
- Includes** Tuning key
- Colours** BK-BK = Black Shell / Black Hardware
R-BK = Red Shell / Black Hardware



The tuning system is outstanding in this price range



NIN017R-BK

NIN017BK-BK

BONGO STAND



The patented NINO® Bongo Stand has been developed especially for kids and their height in order to offer them a safe and comfortable playing position. It can be tilted in a 90° angle and height adjusted from 31" up to 45" so children can play standing up or sitting down. The NINO® Bongo Stand is also suitable for many other common bongo models.

- Material** Chrome plated steel
- Features** Fully height adjustable from 31" to 45"
90° angle adjustable
Tripod stand with rubber feet
Suitable for other common bongo models



The latch of the patented NINO® Bongo Stand holds the bongo absolutely stable



NIN020



ABS DRUMS

The colourful NINO® ABS Drums are not only durable, they also have a powerful sound. Shells made from ABS Plastic and synthetic heads guarantee great stability and a long life. With their low weight of about two pounds and their outstanding workmanship, NINO® ABS Drums are also perfectly suitable for toddlers.

ABS CONGAS

Size 6"
Material ABS Plastic
Features Synthetic head
Includes Nylon strap
Colours G/Y = Green / Yellow
 R/BK = Red / Black
 R = Red



ABS DJEMBES

Size 8"
Material ABS Plastic
Features Synthetic head
Includes Nylon strap
Colours G/Y = Green / Yellow
 R/BK = Red / Black
 R = Red



ABS BONGOS

Size 6 1/2" & 7 1/2"
Material ABS Plastic
Features Synthetic head
Colours BK = Black
 G/Y = Green / Yellow
 R = Red



ABS HAND DRUMS

The multi-coloured NINO® ABS Hand Drums offer more than just tonal variety. The unbreakable shells and durable synthetic heads ensure years of trouble-free use.

Sizes 6"
 10"
 12"
Material ABS Plastic
Features Synthetic head
Includes Wooden beater
Colours B = Blue
 BK = Black
 GR = Green
 R = Red
 Y = Yellow



Because of the patented tuning system, the drums come pretuned and ready to play right out of the box



ABS JINGLE DRUMS

The NINO® Jingle Drums offer enhanced sound options due to attached jingle pairs.

Size 10"
Material ABS Plastic with nickelsilver jingles
Features Synthetic head
Includes Wooden beater
Colours BK = Black
 R = Red



FRAME DRUMS

These NINO® Frame Drums are traditionally equipped with buffalo skin heads and come with a wooden beater. With their warm tone they can be used in various musical occasions.

- Sizes** 12 1/2"
15"
- Material** Buffalo skin heads
- Features** Velcro strap
- Includes** Wooden beater

NIN0554



NIN0553

WOOD TONE BLOCKS

The NINO® Wood Tone Blocks come with two tonally matched resonating bodies and are available in different sizes.

- Sizes** Small
Medium
- Material** Rubber Wood (*Hevea brasiliensis* Muell.-Arg.)
- Features** Tonally matched resonating bodies
- Includes** Wooden beater

NIN0570



NIN0571

WOOD A-GO-GO'S

The NINO® Wood A-go-go's are played with a wooden beater and produce a powerful sound. They can also be scratched like a guiro. These two playing styles leave room for creativity.

- Sizes** 1 row
2 rows
3 rows
- Material** Rubber Wood (*Hevea brasiliensis* Muell.-Arg.)
- Features** Different playing options
- Includes** Wooden beater

NIN0561



NIN0560

NIN0559

WOOD BLOCKS

The Wood Block is probably one of the oldest rhythm instruments and should be part of any percussion group. The NINO® Wood Blocks have an impressive sound and are available in two sizes.

- Sizes** Medium
Large
- Material** Rubber Wood (*Hevea brasiliensis* Muell.-Arg.)
- Includes** Wooden beater

NIN022

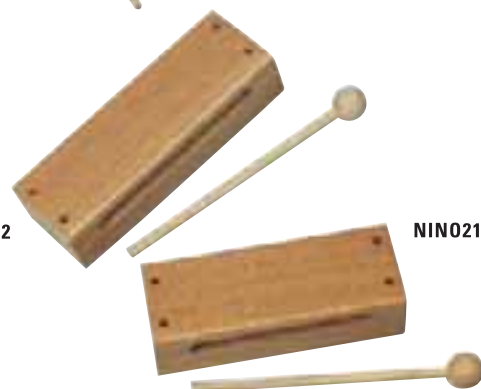

NIN021

ORIENTAL WOOD TONE BLOCKS

The NINO® Oriental Wood Tone Blocks come in two different versions: One model is played by holding it in the player's hand, which produces a slightly dampened sound. The model with the handle has a more high pitched and open sound.

- Material** Rubber Wood (*Hevea brasiliensis* Muell.-Arg.)
- Includes** Wooden beater

NIN0572



NIN0573

WOOD STIRRING DRUM

The eight wooden tongues produce different pitches when they are struck separately, like playing a xylophone. By stirring in the drum with the included beater a scale can be played. The combination of a stirring drum with a handle is an original MEINL Innovation.

- Material** Rubber Wood (*Hevea brasiliensis* Muell.-Arg.)
- Features** Ergonomically shaped handle
- Includes** Wooden beater



NIN0556



WOOD BALL STIRRING DRUMS

The NINO® Wood Ball Stirring Drums are a further development of the familiar stirring drum. The instrument is based on a clever design. When playing the drum, a wooden ball fastened to a nylon string strikes the tonally matched wooden tongues and produces a harmonic sound.

- Sizes** Small
Large
- Material** Rubber Wood (*Hevea brasiliensis* Muell.-Arg.)
- Features** Ergonomically shaped handle



NIN0558

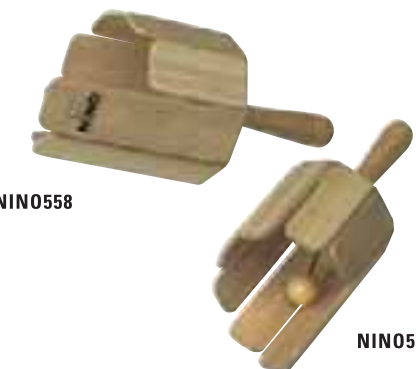

NIN0557



WOOD FROGS

The NINO® Wood Frogs have gained an enormous popularity over the last few years. Children especially love the authentic "ribbit" sound which is created by scratching the wooden beater on the frog's back. Great fun for kids and adults.

- Sizes** Small
Medium
Large
X-large
- Material** Wood
- Features** Creates original "ribbit" sound
- Includes** Wooden scratcher
- Colour** GR = Green



WOOD ANIMALS, MINI

The NINO® Wood Animals are great sounding miniature imitations of a grasshopper, snail, frog, and turtle. Scratching the wooden beater on the surface of the instruments creates a nice guiro-like sound. Great fun for kids and adults.

- Size** Mini
- Material** Wood
- Features** Creates guiro-like sounds



WOOD SHAKERS

Toddlers especially love these little rhythm instruments. NINO® Natural Wood Shakers have different fillings. A cylindrical shaped shaker is available in two different sizes, as well as a square, and a triangular shaped shaker assortment.

- Shapes** Cylindrical, small
Cylindrical, large
Square, 3 pcs set
Triangular, 3 pcs set
- Material** Rubber Wood (*Hevea brasiliensis* Muell.-Arg.)
- Features** Different sounding fillings

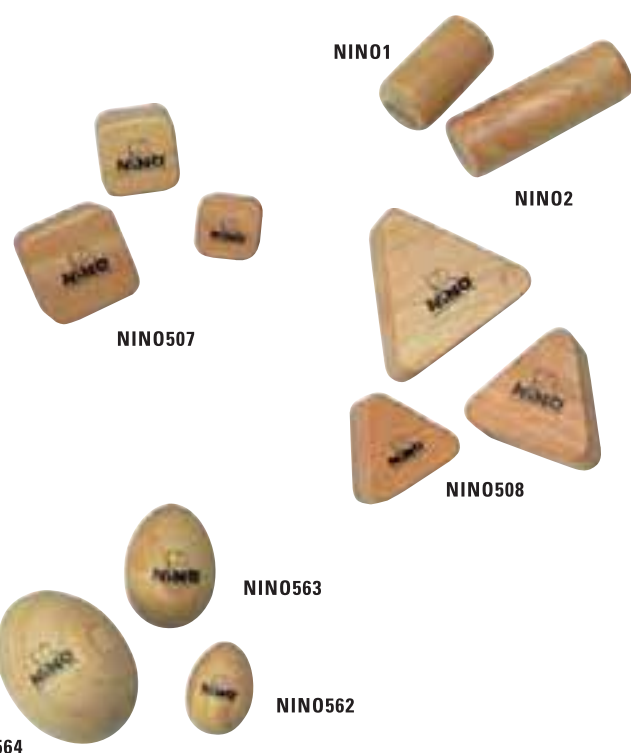

WOOD EGG SHAKERS

NINO® Wood Egg Shakers are very handy because of their shape. They also have a great sound with various pitches depending on their size.

- Sizes** Small
Medium
Large
- Material** Rubber Wood (*Hevea brasiliensis* Muell.-Arg.)

WOOD CLAVES

Claves are an essential instrument in Latin music and shouldn't be missing from any percussion set up. The NINO® Wood Claves are available as regular sized models. A second pair was especially designed to fit a child's hand size.

- Sizes** Small
Regular
- Material** Rubber Wood (*Hevea brasiliensis* Muell.-Arg.)
- Features** Sold as pairs



WOOD EGG MARACAS

Maracas are used for any style of music and are one of the most popular rhythm instruments worldwide. The NINO® Wood Egg Maracas have a nice warm sound and come with an ergonomically shaped handle.

- Sizes** Small
Medium
- Material** Rubber Wood (*Hevea brasiliensis* Muell.-Arg.)
- Features** Ergonomically shaped handle
Sold as pairs



WOOD MARACAS

The NINO® Wood Maracas sound very focused and have more attack.

- Sizes** Small
Medium
- Material** Rubber Wood (*Hevea brasiliensis* Muell.-Arg.)
- Features** Ergonomically shaped handle
Sold as pairs



SKIN MARACAS

NINO® Skin Maracas are entirely hand made and have a warm and mellow sound.

- Sizes** Small
Medium
- Material** Natural skin
- Features** Mellow sound
Ergonomically shaped wood handle
Sold as pairs



SKIN EGG SHAKER

The NINO® Skin Egg Shaker is entirely hand made and has a warm and mellow sound.

- Material** Natural skin



DOUBLE SHAKER

The NINO® Double Shaker produces a clear and cutting sound with enhanced volume.

Material Rattan with natural skin hide bottom

CAXIXI

The NINO® Caxixi produces a clear and cutting sound.

Material Rattan with natural skin hide bottom

BASKET SHAKERS

The NINO® Basket Shakers contain a special filling for a slightly dampened sound.

Sizes Small
Medium
Material Rattan

GANZA SHAKERS

The NINO® Ganza Shakers produce a voluminous sound due to their size.

Sizes Small
Medium
Material Rattan with coconut bottom

WOOD TAMBOURINES

The NINO® Wood Tambourines feature a sturdy wooden frame along with a nice sparkling sound. They are available in a one row construction with 8 nickel silver jingle pairs, or as a two row model with 16 nickel silver jingle pairs.

Size 10" diameter
Material Jingles: Nickel silver
Wooden frame
Features 1 or 2 row versions available



NIN0501

NIN0703



NIN0522

NIN0521



NIN015

NIN014

RACKET TAMBOURINE

The NINO® Racket Tambourines feature a sturdy rattan frame along with a nice sparkling sound. They are available as a one row construction with 9 aluminum jingle pairs. An ergonomically shaped handle makes them perfect for children hands.

Material Frame: Rattan
Jingles: Aluminum
Features Ergonomically shaped and padded handle



NIN0518

WOOD GUIRO SHAKER

The NINO® Wood Guiro Shaker is equipped with a filling and combines a shaker as well as a guiro sound in one instrument.

Material Rubber Wood (*Hevea brasiliensis* Muell.-Arg.)
Features Additional shaker sound
Includes Wooden striker

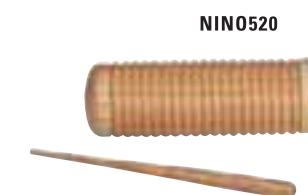

NIN0520



NIN0555

WOOD GUIRO

The guiro is an important instrument which plays a very important part in any percussion set up. Striking the tonal grooves of the NINO® Wood Guiro creates many different sounds.

Material Rubber Wood (*Hevea brasiliensis* Muell.-Arg.)
Includes Wooden striker

CABASAS

The NINO® Cabasa is made from a wooden cylinder covered with a rippled metal plate, which is surrounded by a net of metal beads. Holding the handle with one hand and scratching the metal beads with the other hand on the metal plate creates the classic cabasa sound. The smaller 2" model was especially designed for a child's hand.

Sizes Small
Medium
Material Steel chain and cylinder
Features Ergonomically shaped wooden handle

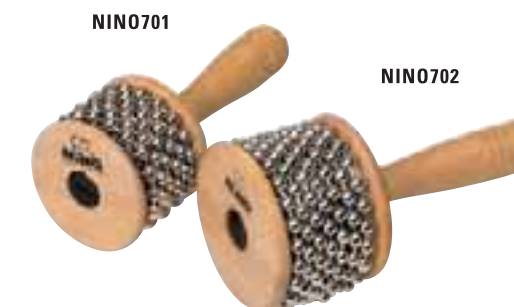

NIN0701

NIN0702



CHIMES

The NINO® Chimes can be mounted on a cymbal stand-, or held by the wooden frame. The 12 bars of the NINO® Chimes are made from a premium aluminum alloy and create a very full and rich sound.

- Size 12 bars
- Material Silver anodized aluminum alloy



NINO600

ENERGY CHIMES

These NINO® instruments have a very cutting “ping” sound. The free floating bars create a very long sustain. NINO® offers three different pitched Energy Chimes, as well as a model with three bars.

- Sizes Small, Medium, Large
- Material Silver anodized aluminum alloy
- Includes Wooden beater



NINO580

NINO579L

NINO579M

NINO579S

TRIANGLES

NINO® Percussion offers three tonally matched triangles. They have a strong sound with a long sustain.

- Sizes 4", 6", 8"
- Material Steel
- Features Wooden holder with braided nylon strap
- Includes Metal beater with rubber padded grip



NINO552

NINO550

NINO551

A-GO-GO BELL

The NINO® A-Go-Go Bell is perfectly sized for children. It is handmade from high quality steel and produces a loud bell sound.

- Material Black powder coated steel



NINO505

JINGLE STICKS

The NINO® Jingle Sticks feature six pairs of nickel silver jingles firmly mounted on a plastic frame with a handle. The jingle stick can be played like a tambourine, or like a drumstick on a conga, bongo, or djembe. New and interesting sounds can be achieved with this instrument.

- Material Jingles: Nickel silver, Frame: ABS
- Features Ergonomically shaped handle, New sound ideas
- Colours BK = Black, R = Red, Y = Yellow



NINO13BK

NINO13R

NINO13Y

MINI FIBERGLASS GUIROS

The NINO® Mini Guiros are made from premium fiberglass. The sound is achieved by scratching the different surfaces of the guiro.

- Size Mini
- Material Premium fiberglass
- Includes Wooden scraper
- Colours BK = Black, R = Red

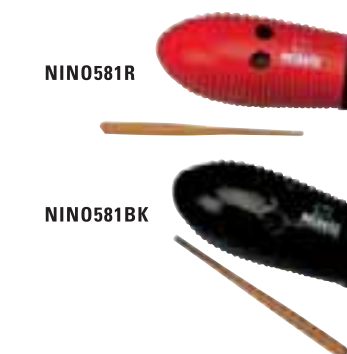

NINO581R

NINO581BK

MINI FIBERGLASS GUIRO SHAKERS

NINO® also offers a Mini Fiberglass Guiro Shaker which combines the sounds of a shaker and a guiro in one instrument.

- Size Mini
- Material Premium fiberglass
- Features Additional shaker sound
- Includes Wooden scraper
- Colours BK = Black, R = Red



NINO583BK

NINO583R

SOUVENIR INSTRUMENTS

The NINO® Souvenir Instruments are very popular as small gifts or ornaments. They are available as a conga, djembe, or bongo. Great fun for everybody.

- Size 3" tall
- Material Rubber Wood (*Hevea brasiliensis* Muell.-Arg.)
- Features Natural hide skins



NINO511

NINO510

NINO512





PLASTIC MARACAS

The NINO® Plastic Maracas are known for their stability, versatility, and strong, projecting sound.

- Material** Plastic
- Features** Ergonomically shaped handle
Sold as pairs
- Colour** R = Red



PLASTIC EGG MARACAS

The NINO® Egg Maracas are made from a special plastic material. They have a very clear and pronounced sound and are perfect maracas for children.

- Size** 6"
- Material** Plastic
- Features** Ergonomically shaped handle
Sold as pairs
- Colour** R = Red



BALL SHAKER

The two shakers are firmly attached to each other with a strong cord. By tightly holding one ball and rhythmically swinging the other one, many sounds can be achieved.

- Material** Plastic
- Features** Attractive Harlekin® design



EGG SHAKERS

NINO® Egg Shakers are vital to every percussion collection. They have an extremely pronounced and crystal clear sound.

EGG SHAKERS

- Material** Plastic
- Colours** B = Blue
BK = Black
GR = Green
R = Red
Y = Yellow



EGG SHAKER, SMALL

- Size** Small
- Material** Plastic
- Colour** BR = Brown



EGG SHAKER ASSORTMENTS

- Material** Plastic
- Sets** Egg Shaker Set 4 pcs.
Egg Shaker Set 80 pcs. including elephant shaped basket

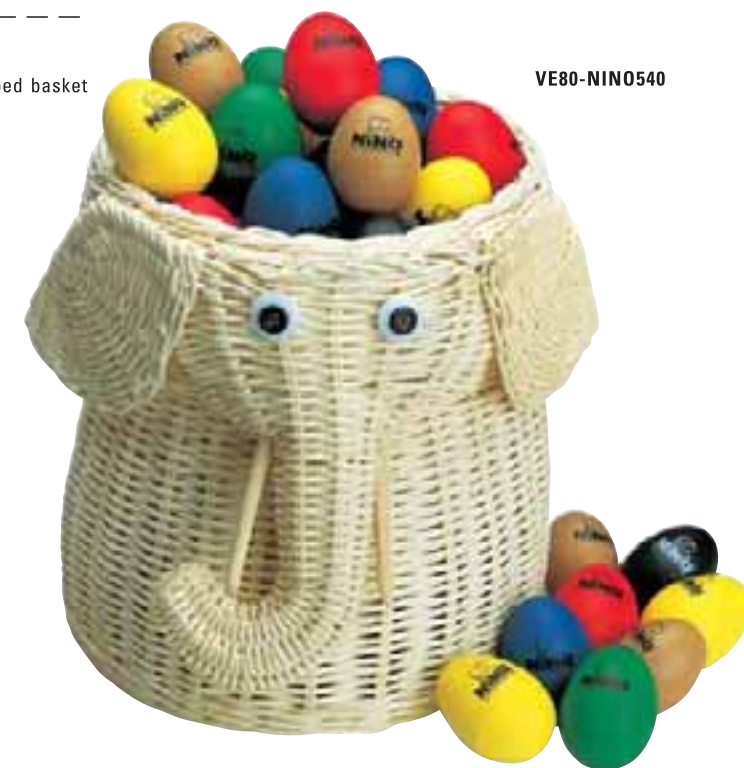



BOTANY SHAKER

The NINO® Botany Shakers are made from a high quality plastic material filled with a specially nice sounding substance. These fruit and vegetable imitations look amazingly real and create a great variety of sounds.

NINO® Botany Shakers have been tested for saliva resistance and can therefore be given to toddlers without any worries.



VE36-NIN0536

BOTANY SHAKER ASSORTMENT, 36 pcs.

Material Plastic
Features Botany Shaker Assortment, 36 pcs. incl. 2 baskets of each 18 pcs.

BOTANY SHAKER ASSORTMENT, 4 pcs.

Material Plastic
Features Botany Shaker Assortment, 4 pcs. "fruit"



NIN0SET100

BOTANY SHAKER ASSORTMENT, 4 pcs.

Material Plastic
Features Botany Shaker Assortment, 4 pcs. "vegetable"



NIN0SET101

NINO® SETS

NINO® instruments have been designed to meet the demands of early childhood education and are perfectly suitable for the use in kindergartens, schools, music therapy and musical activities in the family. Available are two different NINO® Percussion collections which come in a durable nylon Harlekin® design bag. It's the perfect activity for small groups of up to 8 children.

NIN0SET1

Contents 1 x ABS Hand Drum 6"
1 x Wooden Beater
1 x Wood Shaker, large
1 x Skin Maracas pair, small
1 x Jingle Stick
1 x Harlekin® bag

Colours BK = Black
R = Red
Y = Yellow



NIN0SET1

NIN0SET4

Contents 1 x Wood Guiro
1 x Caxixi
1 x Wood Claves pair, small
1 x Triangle, 4"
1 x Egg Shaker
1 x Egg Shaker, small
1 x Botany Shaker, Banana
1 x Botany Shaker, Apple
1 x Harlekin® bag



NIN0SET4



Contents of NIN0SET4



NINO® RYHTHM SETS

These two NINO® Rhythm Sets include 12 or 15 individual instruments. They are perfect for use in kindergarden, schools, or percussion groups. These collections of different instruments are the ideal way to explore the complete NINO® world of percussion and rhythm.

NINOSET12

- Contents**
- 1 x Wood Claves pair, large
 - 1 x Triangle, 6"
 - 1 x ABS Hand Drum 10"
 - 1 x Tambourine, one row
 - 1 x Energy Chime, medium
 - 1 x Wood Guiro
 - 1 x Skin Maracas pair, medium
 - 1 x Basket Shaker, medium
 - 2 x Egg Shaker
 - 1 x Wood A-Go-Go, two rows

NINOSET12



NINOSET15

- Contents**
- 1 x Wood Claves pair, small
 - 1 x Triangle, 4"
 - 1 x ABS Hand Drum 6"
 - 1 x Mini Fiberglass Guiro
 - 1 x Skin Egg Shaker
 - 1 x Egg Maracas pair, small
 - 1 x Basket Shaker, small
 - 1 x Wood Shaker Assortment 3 pcs., square
 - 1 x Wood-Block, medium
 - 1 x Botany Shaker, Banana
 - 1 x Egg Shaker
 - 1 x Jingle Stick
 - 1 x Basket

NINOSET15



CYMBALS

These excellent sounding NINO® Cymbals are made in Germany. They are a high quality product and perfect for music education. They are tonally matched to create a triad when played at the same time.

- Sizes** 12" / 30.5 cm
13" / 33.0 cm
14" / 35.5 cm
- Material** Nickel silver
- Features** Tonally matched
- Includes** Leather strap



CYMBAL PAIRS

NINO® Cymbal Pairs are made in Germany from premium alloys. Different sizes are available in bronze, brass, or nickel silver. All cymbal pairs are tonally matched and are equipped with a leather strap.

- Sizes** 6" / 15.0 cm
7" / 17.5 cm
8" / 20.0 cm
- Material** Bronze, brass, or nickel silver pairs
- Includes** Leather straps



CHINA GONG

Children love the NINO® Tenor Gong which is hand made from a special alloy. Its smooth and relaxing tone reveals magic.

- Size** 12"
- Material** Special alloy
- Features** Smooth and relaxing tone
- Includes** Holder
Beater



MUSIC BAGS

Handy bags made from durable nylon are always useful. This NINO® Music Bag is available in red and the Harlekin® design. Many separate compartments make it ideal for all kind of activities.

- Material** Nylon
- Features** Many compartments
- Colours** HK = Harlekin
R = Red



BONGO BAG

The NINO® Bongo Bag featuring the Harlekin® design can be used for transporting a bongo or other small percussion items.

- Material** Nylon
- Includes** Padded shoulder strap
Carrying grip



SPARE PARTS

Our spare part service has original NINO® heads and lugs for congas, djembes, bongos available separately. Mechanical spare parts for NINO® instruments are also available.

HEADS	
HEAD-NI910-9	9" for conga (NINO910)
HEAD-NI910-10	10" for conga (NINO910)
HEAD-NINO89-8	8" for conga (NINO89)
HEAD-NINO89-9	9" for conga (NINO89)
HEAD-NINO23	10" for djembe
HEAD-NINO3-65	6 1/2" for bongo (NINO3 / NINO17)
HEAD-NINO3-75	7 1/2" for bongo (NINO3 / NINO17)
TUNING LUG	
LUG-NINO910	Lug for conga (NINO910)
LUG-NINO89	Lug for conga (NINO89)
LUG-NINO23	Lug for djembe (NINO23)
LUG-NINO3	Lug for bongo (NINO3 / NINO17)
BEATERS	
NINO9	Wood beater
NINO567	Metal beater



For more information about MEINL percussion products, endorsing artists, tips'n tricks around percussion, exclusive video footage and mp3 downloads, please log on to

meinpercussion.com

SIGN IN & WIN

Take part in the monthly MEINL percussion give away by simply subscribing to the official MEINL Newsletter and receive site updates, product news, clinic and tour dates, exclusive artist updates, and much more.

Every month MEINL gives away valuable prizes to the winner of the monthly contest.
For more details please check out

meinpercussion.com

All features are subject to change without notice. Not responsible for typographic errors. No part of this catalog may be reprinted, reproduced or included in any online-service in any form in whole or in part, without the prior written permission of MEINL PERCUSSION.

©2004 Roland Meinl Musikinstrumente GmbH & Co. KG

Advertising Concept & Design by:
»tollwerk® sinnesnavigatoren & Pari Mahmud, Germany

Content & Direction by:
Udo Heubeck , Norbert Saemann

Photos by:
Studio Waldeck, Andrea Meister, Heinz Kronberger, Alex Solca, James Cumpsty, Stephan Hänisch, Matthias Ketz, Sean Vennet

Printed in Germany M-CA150304

