



THIS IS PERCUSSION

CATALOG 2005



CATALOG 2005

 THIS IS PERCUSSION



meinlpercussion.com



It's the magic
of the most authentic
and deepest kind
of expression!

All features are subject to change without notice. Not responsible for typographic errors. No part of this catalog may be reprinted, reproduced or included in any online-service in any form in whole or in part, without the prior written permission of MEINL percussion.

© 2005 Roland Meinl Musikinstrumente GmbH & Co. KG

Advertising Concept & Design by:
» tollwerk® sinnesnavigatoren & Pari Mahmud, Germany

Content & Direction by:
Udo Heubeck, Norbert Saemann

Photos by:
Studio Waldeck, Andrea Meister, Heinz Kronberger, Alex Solca, James Cumpsty, Stephan Hänisch, David Esarey, Darren England, Sean Vennet

MEINL would like to thank Samba Do Brasil for the provided pictures.
www.samba-do-brasil.de

Printed in Germany M-CA301204



WHAT IS IT ALL ABOUT?

In the course of thousands of years, mankind has evolved into numerous distinct cultures all over the world. All of these cultures have developed their own ancient customs in which rhythm and dance have always played an important role, reflecting the rich history of these cultures.

Many rhythms were unique to individual tribes and their specific part of the world from where they originated, areas such as Africa, the Pacific Nations, Asia, the Caribbean, Native America, South America, Persia, and the Celtic Area (such as Ireland).

Up to this day, many different rhythms can be related specifically to one certain geographical region culture, or even to one tribe. All of these different cultures had one thing in common: They all developed their own sophisticated system of rhythms, instruments, and dances as a fundamental force in their rites, in which the sound of a drum was considered as the heartbeat of mother earth.

Hundreds of years later in times of sailors and discoverers, those customs were transported all over the world and the different rhythms were shared with other cultures. That created the first real "World Music", which combined rhythms and musical styles of many different nationalities. Soon, the rhythms started to take on new developments because of new ideas from other cultures being incorporated into the traditional rites and rhythms. A development began which continues to this day.

Today, hundreds of years later, there are no boundaries anymore. We have the unique opportunity to live this variety to its fullest. A variety of sounds to choose from which not only enriches our music and artform, but also helps us to understand different cultures and their customs.

So live and play VARIETY!

MEINL - THIS IS PERCUSSION!





MEINL GLOBAL HEADQUARTER
GUTENSTETTEN, GERMANY

It is our mission to offer everybody, regardless of being a pro or first time player, the right instrument which matches her or his specific needs. As diverse as those players are, just as diverse are their individual demands.

MEINL
HEADLINER® RANGE

MEINL
PROFESSIONAL RANGE

NINO® PERCUSSION
BY MEINL

MEINL THIS IS:

VARIETY

Over the last 25 years we have created a specific portfolio of ranges to match the variety of our customers. Today we are proud to offer a wide assortment of high quality percussion instruments for players all around the world regardless of age, playing skills, or economic background. A large variety of colours, a well thought out assortment and trend setting ideas is what MEINL Percussion stands for.

INNOVATION

As a modern and progressive company, MEINL has never been content with the status quo! By talking and listening to the people who play, we have developed many new and improved percussion instruments. Original MEINL innovations like the Free Ride System for Bongos (patented), the Floatune® Tuning System for Timbales and Djembes (patented), the revolutionary STEELY II Conga and Djembe Stands (patented), or the Professional Conga and Bongo Stands (patented) prove our leading position in Research and Development work and set the standard in the percussion world.



MEINL GLOBAL HEADQUARTER
Am Bahnhof 2
91468 Gutenstetten
GERMANY
meinpercussion.com

MEINL USA L.C.
3354 Ambrose Avenue
Nashville, TN 37207
USA
meinpercussion.com

RESPONSIBILITY

Our perception of what it means to be a global player tells us not to measure success in sales only; it is also the way how we achieve it! As a family owned and managed company, we conduct business with integrity, respecting our employees, customers, artists, and the environment around us. Therefore we strictly observe the CITES-regulations set forth in the "Convention on International Trade in Endangered Species of Wild Fauna and Flora" and only use wood from environmentally controlled forests or industrial wood plantations.

QUALITY

Since our formation, our main objective has been to offer percussion instruments which comply with the highest quality levels regarding manufacturing and materials used. Only by committing to the highest standards can we guarantee top quality instruments, the maximum of playing comfort, the best possible sounds, and therefore long lasting customer fulfilment.

As one of today's worldwide leading percussion manufacturer with the highest quality standards, a large variety of instruments available, innovative ideas, and a steadily growing roster of professional artists, we can confidently affirm:

MEINL-THIS IS PERCUSSION!





MY CHOICE

HEADLINER® RANGE

MY CHOICE

MEINL's Headliner® Range of Percussion features great quality, sound and workmanship at an affordable price.

It offers first time as well as advanced players percussion instruments which meet the highest standards.

Selected materials, accurate converting and stability guarantee a long lasting enjoyment of the MEINL Headliner® Range.



HEADLINER® RANGE CONGA SETS

Get started with the MEINL Headliner® Range Conga Sets. They offer outstanding quality and great value in the budget price range, yet are equipped with many features known from professional instruments. Ideal for the student and hobbyist.

HC555 WOOD CONGAS

- Sizes** 10" & 11" Conga Set
28" tall
- Material** Rubber Wood (*Hevea brasiliensis* Muell.-Arg.)
- Features** Hand selected buffalo heads
8 mm strong tuning lugs
Original MEINL style tuning brackets
2 mm rounded rims
Black powder coated hardware
- Includes** Height adjustable basket stands with quick set up system (patent pending)
Tuning key
- Colours** BSB = Blue Burst
NT = Natural
VSB = Vintage Sunburst
WR = Wine Red
- Finish** Hi Gloss



HC555NT

IMPROVED



Height adjustable



U-shaped notches allow quick set up and breakdown



Black powder coated 2 mm rounded rims



Rubber ringed bottoms for more stability and protection

HC512 WOOD CONGAS

- Sizes** 11" & 12" Conga Set
28" tall
- Material** Rubber Wood (*Hevea brasiliensis* Muell.-Arg.)
- Features** Hand selected buffalo heads
8 mm strong tuning lugs
Original MEINL style tuning brackets
2 mm rounded rims
Black powder coated hardware
- Includes** Height adjustable basket stands with quick set up system
Tuning key
- Colours** BSB = Blue Burst
NT = Natural
VSB = Vintage Sunburst
WR = Wine Red
- Finish** Hi Gloss



HC512WR

HC888 WOOD CONGAS

- Sizes** 10" & 11" Conga Set
28" tall
- Material** Rubber Wood (*Hevea brasiliensis* Muell.-Arg.)
- Features** Hand selected buffalo heads
8 mm strong tuning lugs
Original MEINL style tuning brackets
2 mm rounded rims
Black powder coated hardware
- Includes** Height adjustable double braced tripod stand
Tuning key
- Colours** BSB = Blue Burst
NT = Natural
VSB = Vintage Sunburst
WR = Wine Red
- Finish** Hi Gloss



HC888VSB



MSTC0B-1011

NEW

CONGA BAG SET

The MEINL Headliner® Range Conga Bag Set offers dependable protection at an affordable price, making transportation as hassle free as possible.

- Sizes** 10" & 11" Conga Bag Set
- Material** Heavy duty padded nylon
- Features** Shoulder strap
Carrying grip

HC812 WOOD CONGAS

- Sizes** 11" & 12" Conga Set
28" tall
- Material** Rubber Wood (*Hevea brasiliensis* Muell.-Arg.)
- Features** Hand selected buffalo heads
8 mm strong tuning lugs
Original MEINL style tuning brackets
2 mm rounded rims
Black powder coated hardware
- Includes** Height adjustable double braced tripod stand
Tuning key
- Colours** BSB = Blue Burst
NT = Natural
VSB = Vintage Sunburst
WR = Wine Red
- Finish** Hi Gloss



HC812BSB

CONGA SETS



HEADLINER® RANGE

WOOD BONGOS

MEINL Headliner® Range Bongos are perfect for the student or hobbyist who is looking for a high quality instrument right from the beginning.

- Sizes** 6 3/4" Macho & 8" Hembra
- Material** Rubber Wood (*Hevea brasiliensis* Muell.-Arg.)
- Features** Hand selected buffalo heads
8 mm strong tuning lugs
2 mm rounded rims
Black powder coated hardware
Interior backing plates
- Includes** Tuning key
- Colours** BSB = Blue Burst
NT = Natural
VSB = Vintage Sunburst
WR = Wine Red
- Finish** Hi Gloss



Interior backing plates add strength to construction

BONGO BAG

The MEINL Headliner® Range Bongo Bag offers dependable protection at an affordable price making transportation as hassle free as possible.

- Size** Bongos up to 7 1/2" Macho & 8 1/2" Hembra
- Material** Heavy duty padded nylon
- Features** Padded shoulder strap
Carrying grip



MSTBB

TIMBALES

The MEINL Headliner® Range Timbales come in 13" and 14" sizes, are made from chrome plated steel and come with a heavy duty-, height adjustable tilting stand. They provide the classic timbale sound and are the perfect introduction to the joy and passion of timbale playing at an affordable price.

- Sizes** 13" & 14"
- Material** Chrome plated steel
- Includes** Height adjustable tilting double braced tripod stand
Tuning key
Wrench
Cowbell holder



HT1314CH

BONGO STAND

The MEINL Headliner® Range Bongo Stand ensures a stable and reliable placing of your bongo. A stress-free and quick setup solution at an affordable price. Fits other bongo brands as well.

- Material** Chrome plated steel
- Features** Height adjustable
Double braced tripod stand
Fits other brands
Memory lock
- Includes** Wrench



A stable metal clamp holds the entire unit in place



HBS

WOOD DJEMBES

If you are looking for an affordable djembe for drum circles or spontaneous jam sessions, don't look any further! The MEINL Headliner® Range Djembes have it all! Equipped with hand selected goat heads they produce the classic djembe sounds reaching from fat basses to rich open tones and cutting slaps.

- Size** 12"
- Material** Rubber Wood (*Hevea brasiliensis* Muell.-Arg.)
- Features** 23 1/2" tall
8 mm strong tuning lugs
2 mm rounded rims
Original MEINL style tuning brackets
Black powder coated hardware
Hand selected goat heads
- Includes** Tuning key
- Colours** BSB = Blue Burst
NT = Natural
VSB = Vintage Sunburst
WR = Wine Red
- Finish** Hi Gloss



HDJ600BSB

HDJ600VSB

HDJ600NT

HDJ600WR

CAJON

The MEINL Headliner® Cajon delivers the classic cajon sound at an affordable price and can be used in Flamenco or World Music. It is also very useful during unplugged gigs for delivering the rhythmic foundation for a whole band when a full drum set can't be used. For more sound options, the top corners of the cajon can be adjusted, allowing the player to customize the amount of snap desired.

- Material** Rubber Wood (*Hevea brasiliensis* Muell.-Arg.)
- Features** Adjustable top corners
Built in size effect
Anti-slipping sitting surface
- Includes** Allen wrench
- Colour** NT = Natural
- Finish** Hi Gloss



HCAJ1NT

BONGOS, TIMBALES, DJEMBES, CAJON



HEADLINER® RANGE

HEADLINER® RANGE DANCING DRUMS

The MEINL Headliner® Range Dancing Drums are the perfect instruments for educational or street percussion. They are made from high quality materials and produce great sounds. A great gift idea as well.

FIBERGLASS DANCING DJEMBES

Size 12" / 22 3/4" tall
Material Premium fiberglass
Features 7 mm strong tuning lugs
 2.2 mm rounded rim
 Black powder coated hardware
Includes Nylon strap
 Tuning key
Colours BK = Black
 R = Red



HDJ400R

HDJ400BK

FIBERGLASS FAMILY DRUMS

Sizes 8 3/4" / 8" / 7 1/2" / 13 1/2" / 11 1/4" / 9 3/4" tall
Material Premium fiberglass
Features 8 mm strong tuning lugs
 Traditional rim
 Black powder coated hardware
Includes Nylon strap
 Tuning key



HFDD2R

HFDD3Y

HFDD1BK

FIBERGLASS DANCING CONGAS

Size 8 1/2" / 24" tall
Material Premium fiberglass
Features 7 mm strong tuning lugs
 1.6 mm rounded rim
 Black powder coated hardware
Includes Nylon strap
 Tuning key
Colours BK = Black
 R = Red



HC301R

HC301BK

FIBERGLASS MINI DANCING DJEMBES

Size 8" / 14 1/3" tall
Material Premium fiberglass
Features Traditional rim
 Black powder coated hardware
 Floatune® Tuning System
Includes Nylon strap
 Tuning key
Colours B = Blue
 G = Green
 Y = Yellow



HDJ200Y

HDJ200G

HDJ200B

RAMWONGS

Ramwong is a Thai folk dance which evolved from Ramthone, a popular festive season in a certain region in Thailand. Ram means dance and Thone is a small drum. Ramthone can be explained as dancing to the accompaniment of the drum beats. The MEINL Headliner® Ramwongs produce the authentic sound that is heard in those ceremonies.

Sizes 7" diameter, 10" tall / 8" diameter, 15" tall
Material Wood
Features Natural rawhide
 Traditional rope tuning system



RAMWONG8

RAMWONG7

CHIMES

The MEINL Headliner® Range Chimes are a great and affordable addition to any percussion set up! They are made from high quality materials and produce a full and warm chime sound.

Size 27 bars
Material Silver anodized aluminum alloy
Colour R = Red



HCH1R

COWBELLS

Made from black powder coated steel, the MEINL Headliner® Range Cowbells produce a cutting and sharp sound. Whether used in a percussion set up or in a drum set configuration, they always add a special flavor to your groove.

Sizes 5" / 8"
Material Black powder coated steel



HC04BK

HC02BK

JINGLE STICKS

The MEINL Headliner® Range Jingle Sticks are a nice and affordable alternative to a tambourine. It can be used in drum circles, gatherings, street percussion and educational fields. Nice sound effects are also achieved when used as a stick on a drum.

Material Jingles: Nickelsilver plated steel
 Frame: ABS
Colours BK = Black
 R = Red



HJS1R

HJS1BK

WOOD CONGUITAS

The MEINL Headliner® Range Conguitas are a perfect addition to any percussion set up. They are made from high quality materials and produce a cutting and strong percussive tone which complements the congas in a harmonically supportive sound spectrum. A heavy duty stand which can be tilted holds the drums securely.

Sizes 8" & 9"
Material Rubber Wood (*Hevea brasiliensis* Muell.-Arg.)
Features 8 mm strong tuning lugs
 Original MEINL style tuning brackets
 Traditional rim
 Black powder coated hardware
 Hand selected buffalo heads
Includes Height adjustable tilting double braced tripod stand
 Tuning key
 Wrench
Colour NT = Natural
Finish Hi Gloss



HCG89NT





NO COMPROMISES

PROFESSIONAL RANGE

NO COMPROMISES

MEINL's Professional Range of Percussion is designed for working musicians and professional players with the highest demands.

Only the finest quality materials are used to produce the best sounding and most functional percussion instruments.

MEINL's Research and Development Team, along with the expertise of top professional players, have raised the bar line with the MEINL Professional Range.





MIPA AWARD FOR MEINL PROFESSIONAL SERIES CONGAS

The "Musikmesse International Press Award" is annually presented by 55 music magazines from all over the world who get together and vote the best products in certain categories. The MEINL Professional Series Congas won the Mipa Award in the "best percussion product" category.



RUBBER WOOD (*Hevea brasiliensis* Muell.-Arg.)

The traditional plantation of rubber wood (*Hevea brasiliensis* Muell.-Arg) in Thailand meets all ecological requirements. In a natural evolution, new trees are planted and the older ones, which have ceased to provide latex, are harvested. In this way, plenty of raw material is available and the valuable rain forest eco-system is preserved. In addition to rubber wood (*Hevea brasiliensis* Muell.-Arg.), we also utilize American White Ash (*Fraxinus americana* L.) which also meets all the CITES-regulations set in the "Convention on International Trade in Endangered Species of Wild Fauna and Flora".



FIBERGLASS

Many percussionists prefer the sound of fiberglass instead of wood, because fiberglass produces a more compact sound with an appealing spectrum of overtones. Premium fiberglass is manufactured by hand laminating layer upon layer which requires extreme patience and dexterity. The result is a truly professional instrument with a unique sound quality.



TRUE SKIN BUFFALO

MEINL True Skin Buffalo Heads are without a doubt the perfect choice for both wood and fiberglass congas due to their structure, thickness, and sonic characteristics. True Skin hides are selected by specialists. After the selection process, each skin is gently tanned using a special MEINL procedure and then mounted by hand to become a first class True Skin Head.



SSR

The MEINL Safe & Sound-Rim (SSR) for congas features a rounded profile to support a comfortable playing feel and prevents palm injuries.



TTR

The MEINL Traditional-Tuning-Rim (TTR) for congas represents the traditional "Cuban Style". It is narrowly placed around the shell and enhances the overall conga sound.



CONGA SAVER

The patented Conga Saver is truly a MEINL innovation. Available in 8 mm and 10 mm versions, they are placed over the conga lugs to prevent them from damaging and scratching the shell while the conga remains fully tuneable.



FLOATUNE® TUNING SYSTEM

The Floatune® Tuning System is an unique feature and truly another MEINL innovation. It is mounted without having to drill into the shells and allows them to vibrate freely.



CONGAS



MARATHON®
CLASSIC SERIES

MARATHON® CLASSIC SERIES

The MEINL Marathon® Classic Series Congas set the standard in this price range by which other wood congas are judged. They combine professional features at a very attractive price price.

- Sizes** 11" Quinto, 11 3/4" Conga, 12 1/2" Tumba
30" tall
- Material** Two ply Rubber Wood (*Hevea brasiliensis* Muell.-Arg.)
- Features** True Skin Buffalo Heads
8 mm strong tuning lugs
2.6 mm rounded SSR-Rims
Black powder coated hardware
- Includes** Steely II Conga Stand (patented)
MEINL Conga Saver (patented)
Accessory pouch
L-shaped tuning key
Tune Up Oil
- Colours** CR-M = Cherry Red
GSB-M = Gold Sunburst
SNT-M = Super Natural
Matt
- Finish** Matt



Juan Carlos Melian, Spain (independent): "The improved MEINL Marathon® Classic Congas are professional sounding instruments with top features! They are unbeaten in their price range and offer both students and pro players an absolutely top notch instrument."



IMPROVED



Conga Saver (patented)
Black powder coated
2.6 mm rounded SSR-
Rim



Metal spike
attachement on every
rubber foot,
L-shaped legs
(patented)



Height adjustable



U-shaped notches
allow quick set up and
breakdown (patent
pending)

16

17



Photos by Studio Waldeck

A DAY ON THE ROAD WITH LUIS CONTE

Phil Collins 'First Final Farewell Tour 2004'
July 01, 2004 / Barcelona Spain



These drums make my hands feel good!



CONGAS



LUIS CONTE
ARTIST SERIES



8 mm tuning lugs
Black powder coated
4 mm traditional
TTR-Rim
Conga Saver (patented)

ARTIST SERIES

Grammy-winner Luis Conte is an acknowledged master of percussion. His celebrated career includes touring and/or recording with some of the greatest names in contemporary music, including Madonna, Eric Clapton, James Taylor, Santana, Celine Dion, Barbara Streisand, Backstreet Boys, Ray Charles and Cuban legends Arturo Sandoval and Chachao. He can also be heard on the scores and/or soundtracks to movies such as Mission Impossible, Rain Man, Disney's animated Tarzan, and many more.

Throughout 2004 Luis has been on Phil Collins' "First Final Farewell Tour" complementing the band and Phil's music with tasteful and musical percussion parts. The tour has been captured on film and a brand new DVD, "Phil Collins – Finally...The First Final Farewell Tour" has been released.

All of Luis' specifications have been achieved with the MEINL Artist Series Luis Conte Signature Congas. They combine the charm and sound of the old traditional Cuban drums with modern features and innovations. The congas are equipped with traditional rims and are mounted as close to the shell as possible, and when combined with MEINL's True Skin Buffalo Heads, enable an even more controlled sound and easier tuning.

- Sizes** 11" Quinto, 11 3/4" Conga, 12 1/2" Tumba
30" tall
- Material** Two ply Rubber Wood (*Hevea brasiliensis* Muell.-Arg.)
Features True Skin Buffalo Heads
8 mm strong tuning lugs
4 mm traditional TTR-Rims
Black powder coated hardware
- Includes** MEINL Conga Saver (patented)
MEINL Soundpads
Accessory pouch
L-shaped tuning key
Tune Up Oil
- Colour** NT-M = Natural
Finish Matt



LC11NT-M

LC1134NT-M

LC1212NT-M



CONGAS



MARATHON®
EXCLUSIVE SERIES

MARATHON® EXCLUSIVE SERIES

The MEINL Marathon® Exclusive Series Wood Congas include many professional features. Ideal for the working percussionist who demands a great sound combined with quality and excellent craftsmanship.

- Sizes** 11" Quinto, 11 3/4" Conga, 12 1/2" Tumba
30" tall
- Material** Two ply Rubber Wood (*Hevea brasiliensis* Muell.-Arg.)
- Features** True Skin Buffalo Heads
8 mm strong tuning lugs
3.2 mm rounded SSR-Rims
Chrome plated hardware
- Includes** Steely II Conga Stand (patented)
MEINL Conga Saver (patented)
MEINL Soundpads
Accessory pouch
L-shaped tuning key
Tune Up Oil
- Colours** ARF = Aztec Red Fade
GAB = Gold Amber Sunburst
NT = Natural
- Finish** Hi Gloss



MEINL's Professional Conga Bags provide a dependable protection and make transporting your instruments as hassle free as possible. (see page 35)



MEC11NT

MEC1212NT

MEC1134NT



MEC11GAB

MEC1212GAB

MEC1134GAB



MEC11ARF

MEC1212ARF

MEC1134ARF

22



8 mm tuning lugs
Conga Saver (patented)
Soundpads
Chrome plated 3.2 mm
rounded SSR-Rim



Metal spike attachment
on every rubber foot,
L-shaped legs (patented)



Height adjustable



U-shaped notches
allow quick set up and
breakdown (patent
pending)

23



CONGAS



FIBERCRAFT® SERIES

MEINL Fibercraft® Congas offer great quality, durability, volume, and the resistance to climatic changes. They have a great presence and brilliancy in sound. Great for live playing and extensive road use.

- Sizes** 11" Quinto, 11 3/4" Conga, 12 1/2" Tumba 30" tall
- Material** Premium fiberglass
- Features** True Skin Buffalo Heads
4 mm rounded SSR-Rims
10 mm strong tuning lugs
Chrome plated hardware
- Includes** MEINL Conga Saver (patented)
MEINL Soundpads
Accessory pouch
L-shaped tuning key
Tune Up Oil
- Colours** BSP = Blue Sparkle
JBK = Jet Black
RSP = Red Sparkle
STS = Sterling Silver



Jen Lowe, USA (Jason Mraz, AC/DC): "I've been taking the MEINL Fibercraft® Congas out on the road a lot lately. I get the presence on stage I need along with the warmth all in one instrument. And they look fantastic, especially with all the different stage lights, it creates stunning effects."



FC11BSP

FC1134BSP

FC1212BSP



FC11JBK

FC1134JBK

FC1212JBK



FC11RSP

FC1134RSP

FC1212RSP



10 mm tuning lugs
Conga Saver (patented)
Soundpads
Chrome plated 4 mm rounded SSR-Rim



FC11STS

FC1134STS

FC1212STS

CONGAS



FLOATUNE® SERIES

FLOATUNE® SERIES

The Floatune® Tuning System is a true and unique MEINL innovation. All mounting hardware is completely isolated from the shell and is secured without any drilling which allows the shell to vibrate freely.

- Sizes** 10" Nino, 11" Quinto, 12" Conga, 13" Tumba
30" tall
- Material** Two ply Rubber Wood (*Hevea brasiliensis* Muell.-Arg.)
- Features** Floatune® Tuning System
True Skin Buffalo Heads
4 mm rounded SSR-Rims
10 mm strong tuning lugs
Chrome plated hardware
- Includes** MEINL Conga Saver (patented)
MEINL Soundpads
Accessory pouch
L-shaped tuning key
Tune Up Oil
- Colours** NT = Natural
VSB = Vintage Sunburst
- Finish** Hi Gloss



10 mm tuning lugs
Conga Saver (patented)
Soundpads
Chrome plated 4 mm rounded SSR-Rim

The Floatune® Tuning System allows the shell to vibrate freely



FL10VSB

FL11VSB

FL12VSB

FL13VSB



FL10NT

FL11NT

FL12NT

FL13NT



Adel Gonzales, Cuba (Afro Cuban Allstars): "I play a quartet of the MEINL Floatune® Congas live with the Allstars. The revolutionary Floatune® tuning system adds a little bit of resonance to their sound which I like a lot. I love 'em."



PROFESSIONAL SERIES

Roland Meinl

The Roland Meinl Professional Series Congas - one of the finest instruments in the MEINL Percussion program and the preferred conga model by many top congueros. Outstanding in look and sound reaching from fat basses to cutting slaps with a great warm overall tone. They have set the standard in the professional conga ranges.

- Sizes** 11" Quinto, 11 3/4" Conga, 12 1/2" Tumba 30" tall
- Material** Two ply Rubber Wood (*Hevea brasiliensis* Muell.-Arg.)
- Features** True Skin Buffalo Heads
10 mm strong tuning lugs
4 mm rounded SSR-Rims
Chrome plated hardware
- Includes** MEINL Conga Saver (patented)
MEINL Soundpads
Accessory pouch
L-shaped tuning key
Tune Up Oil
- Colours** CR = Cherry Red
GAB = Gold Amber Sunburst
NT = Natural
- Finish** HI Gloss



The MEINL Professional Conga Stand (patented) offers a reliable positioning within any percussion set up (see page 35).



10 mm tuning lugs
Conga Saver (patented)
Soundpads

Chrome plated 4 mm
rounded SSR-Rim



MP11GAB

MP1134GAB

MP1212GAB



MP11CR

MP1134CR

MP1212CR



MP11NT

MP1134NT

MP1212NT



CONGAS



ARTIST SERIES

ARTIST SERIES

Ramon "Mongo" Santamaria was without a doubt one of the most respected conga players ever and a pioneer of modern Latin Jazz. During the 50's his band "Black Cuban Diamonds" laid down the foundation for an outstanding career. He has recorded dozens of legendary percussion albums. Worldwide Jazz hits, such as "Watermelon Man" in 1963 and the album "Summertime" from 1980 are only two of the many recordings from this great master percussionist. Mongo has inspired more percussionists around the globe than any other conguero.

Mongo Santamaria died at the Baptist Hospital in Miami, USA in February 2003. He was 85 years old.

It is with great appreciation and deepest respect that we honour our friend and his life's work with his MEINL Artist Series Mongo Santamaria Congas.

Mongo Santamaria



- Sizes** 11" Quinto, 11 3/4" Conga, 12 1/2" Tumba
30" tall
- Material** Two ply American White Ash (*Fraxinus americana* L.)
True Skin Buffalo Heads
- Features** 10 mm strong tuning lugs
4 mm rounded SSR-Rims
Gold tone hardware
- Includes** MEINL Conga Saver (patented)
MEINL Soundpads
Accessory pouch
L-shaped tuning key
Tune Up Oil
- Colour** AWA = American White Ash
Finish Hi Gloss

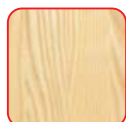

Two ply American White Ash (*Fraxinus americana* L.)



Gold tone 4 mm rounded SSR-Rim



10 mm tuning lugs
Conga Saver (patented)
Soundpads



MSA11AWA

MSA1212AWA

MSA1134AWA

SPECIAL EDITION ARTIST SERIES

As a special tribute to our friend and inspiration, the legendary Mongo Santamaria, MEINL offers the Special Edition Artist Series Mongo Santamaria Congas. Made with dedication, from only the finest hand selected materials, these drums sound as original and musical as their mentor, Mongo Santamaria and the MEINL Special Edition Artist Series Congas – a legendary combination.



- Sizes** 11" Quinto, 11 3/4" Conga, 12 1/2" Tumba
30" tall
- Material** Two ply American White Ash (*Fraxinus americana* L.)
True Skin Buffalo Heads
- Features** 10 mm strong tuning lugs
4 mm rounded SSR-Rims
Chrome plated hardware
MEINL Conga Saver (patented)
MEINL Soundpads
Accessory pouch
L-shaped tuning key
Tune Up Oil
- Colour** ZFA-M = Zebra Finished Ash
Finish Matt



10 mm tuning lugs
Conga Saver (patented)
Soundpads



Chrome plated 4 mm
rounded SSR-Rim



Two ply American White
Ash (*Fraxinus americana* L.)



MSA112ZFA-M

MSA1212ZFA-M

MSA1134ZFA-M

CONGAS



WOODCRAFT® SERIES

WOODCRAFT® SERIES

The MEINL Woodcraft® Series Congas stand for tradition combined with exceptional workmanship. Only the finest hand selected materials are used to produce these premium drums. Their "Cuban Style" shaped shells provide a broad range of different tonal characteristics. It blends warm bass tones, soft open tones, and sharp slaps into one powerful drum and at the same time yields extraordinary projection.



Ray Yslas, USA (Christina Aguilera):
"These are the most beautiful congas I have ever seen! They combine both worlds – traditional Cuban roots with modern features and exceptional workmanship. They are perfect in sound, feel, and look – period."

- Sizes** 11" Quinto, 11 3/4" Conga, 12 1/2" Tumba
30" tall
- Material** Two ply American White Ash (*Fraxinus americana* L.)
- Features** True Skin Buffalo Heads
10 mm strong tuning lugs
4 mm traditional TTR-Rims
Chrome plated hardware
Handle welded to the rim
- Includes** MEINL Conga Saver (patented)
MEINL Soundpads
Accessory pouch
L-shaped tuning key
- Colour** Tune Up Oil
- Finish** ZFA-M = Zebra Finished Ash
Matt



Traditional, Cuban Style shell for enhanced volume



Two ply American White Ash (*Fraxinus americana* L.)



Chrome plated 4 mm traditional TTR-Rim
Handle welded to the rim



10 mm tuning lugs
Conga Saver (patented)
Soundpads



WC112FA-M

WC1212ZFA-M

WC1134ZFA-M



STEELY II CONGA STANDS (patented)

The MEINL Steely II Conga Stands (patented) incorporate several revolutionary and patented new designs. It features 90° angled legs for more stability. A metal spike attached to the bottom of every leg holds the stand in place and prevents movement. A U-shaped notch built in the ring of the stand allows a very quick set up and breakdown. Moreover, the stand is fully height adjustable and available for all MEINL Professional Range Congas.



Original MEINL innovation: Height adjustability

L-shaped legs and metal spike attachments (patented)

Easy set up system (patent pending)

- Material** Steel
Features Patented designs
 Metal spike attached to each leg
 L-shaped legs
 U-shaped notch for quick set up and breakdown
 Fully height adjustable
Includes Allen wrench

MODELS:

For **MARATHON® Classic Series Congas**
 For **Luis Conte Artist Series Congas**

ST-MCC11BK	11"	Black powder coated
ST-MCC1134BK	11 3/4"	Black powder coated
ST-MCC1212BK	12 1/2"	Black powder coated

For **MARATHON® Exclusive Series Congas**

ST-MEC11CH	11"	Chrome plated
ST-MEC1134CH	11 3/4"	Chrome plated
ST-MEC1212CH	12 1/2"	Chrome plated

For **Floature® Series Congas**

ST-FL10CH	10"	Chrome plated
ST-FL11CH	11"	Chrome plated
ST-FL12CH	12"	Chrome plated
ST-FL13CH	13"	Chrome plated

For **Professional Series Congas**

For **Fibercraft® Series Congas**

For **Special Edition Artist Series Congas**

ST-MP11CH	11"	Chrome plated
ST-MP1134CH	11 3/4"	Chrome plated
ST-MP1212CH	12 1/2"	Chrome plated

For **Artist Series Congas**

ST-MSA11G	11"	Gold tone
ST-MSA1134G	11 3/4"	Gold tone
ST-MSA1212G	12 1/2"	Gold tone

For **Woodcraft® Series Congas**

ST-WC11CH	11"	Chrome plated
ST-WC1134CH	11 3/4"	Chrome plated
ST-WC1212CH	12 1/2"	Chrome plated



Easy and effective height extension

STEELY II CONGA STAND HEIGHT EXPANDER SET

Those innovative add-ons to the MEINL Steely II Conga Stands (patented) allow an easy and effective height extension in order to allow a more comfortable playing position for taller congueros.

NEW

- Material** Steel
Features Easy and effective height extension
Includes Mounting screws
 Allen wrench
Finishes Black powder coated
 Chrome plated
 Gold tone



PROFESSIONAL CONGA STAND (patented)

The patented MEINL Conga Stand is unique with respect to design and function. It was especially developed to accommodate the rigors of professional road use where fine adjustment and durability are demanded. It is fully height adjustable and securely fixed by means of the three legs of the stand.

- Material** Chrome plated steel
Features Patented design
 Rubber padded crossbeams
 Fully height adjustable
 Folds up to a compact unit
Includes Allen wrench
 Memory locks



The lightweight stand can be folded to a compact unit which requires little space



TMC-CH

PROFESSIONAL CONGA BAGS

The MEINL Conga Bags come in three sizes: Quinto, Conga, and Tumba. An additional upright zipper simplifies packing and unpacking of your drum. Additional features are padded backpack straps and an external pocket for accessories.

- Sizes** 11"
 11 3/4"
 12 1/2"

- Material** Heavy duty padded nylon
Features Additional upright zipper
 External pocket
 Padded backpack straps
 Carrying grip



Additional upright zipper



MCOB-11

MCOB-1134

MCOB-1212

**MIPA AWARD FOR FREE RIDE SERIES
COLLECTION WOOD BONGOS**

The "Musikmesse International Press Award" is annually presented by 55 music magazines from all over the world who get together and vote the best products in certain categories. The MEINL Collection Series Bongos won the Mipa Award in the "best percussion product" category.



THE PATENTED MEINL
FREE RIDE SUSPENSION SYSTEM

HAS REVOLUTIONIZED THE BONGO WORLD!



FREE RIDE SUSPENSION SYSTEM

The Macho and Hembra are no longer attached to each other by a wooden block mounted between the shells spoiling the resonance of the instrument. Whereas with the patented MEINL Free Ride Suspension System the two drums are firmly attached utilizing the bottom rims which results in not having to drill into the bongo shells. It allows for the first time ever, freely resonating bongo shells.



TRUE SKIN COW HEADS

The original MEINL True Skin Cow Heads are the perfect sounding hides for bongos and meet all requirements demanded by professional players. They have outstanding sound qualities, are easy to tune, resistant, and have a smooth surface for comfortable playing. True Skin hides are selected by specialists. After the selection process, each skin is gently tanned using a special MEINL procedure and then mounted by hand to become a first class True Skin Head.



RESONANCE SHAPING AREA

The MEINL Resonance Shaping Area is a fine solution to enhance the resonance of the bongos. The center part of the two bongo shells are crafted thinner than usual while still maintaining its full stability. The result is a superior timbre and better resonance of the instrument.



SSR

The MEINL Safe & Sound-Rim (SSR) for bongos features a rounded profile to support a comfortable playing feel and to assist in the prevention of palm injuries.



TTR

The MEINL Traditional-Tuning-Rim (TTR) for bongos represents the traditional "Cuban Style". They are narrowly placed around the shells and enhance the overall bongo sound.

BONGOS



COLLECTION BONGOS
WOODCRAFT® BONGO
WOOD BONGOS

FREE RIDE SERIES (patented) COLLECTION WOOD BONGOS

MEINL Collection Series Wood Bongos are the finest bongos available today. They are made entirely by hand and exhibit unparalleled sound, charm, and workmanship. MEINL's expertise in wood selection enabled to study the sonic properties of a large variety of exclusive woods. These extensive studies now reflect in the excellence of these collectors item bongos. The patented MEINL Free Ride System allows freely resonating bongo shells.

- Sizes** 7" Macho & 8 1/2" Hembra
Materials AWA-M = American White Ash (*Fraxinus americana* L.)
 ROW-M = Rose Wood (*Pterocarpus macrocarpus* Kurz)
 TW-M = Teak Wood (*Tectona grandis* L.f.)
Features MEINL Free Ride Suspension System (patented)
 Chrome plated hardware
 True Skin Cow Heads
 8 mm strong tuning lugs
 3 mm rounded SSR-Rims
 Resonance Shaping Area
Includes Accessory pouch
 L-shaped tuning key
 Tune Up Oil
Finish Matt



Original True Skin Cow Heads
 Chrome plated 3 mm rounded SSR-Rims



FREE RIDE SERIES (patented) WOODCRAFT® BONGO

The MEINL Woodcraft® Bongo, just as the Woodcraft® Congas, stands for tradition combined with exceptional workmanship. Only the finest hand selected materials are used to produce this premium bongo which produces the authentic and typical loud slapping bongo sound. The patented MEINL Free Ride System allows freely resonating bongo shells.

- Sizes** 7" Macho & 9" Hembra
Material American White Ash (*Fraxinus americana* L.)
Features MEINL Free Ride Suspension System (patented)
 Chrome plated hardware
 True Skin Cow Heads
 8 mm strong tuning lugs
 4 mm traditional TTR-Rims
 Resonance Shaping Area
Includes Accessory pouch
 L-shaped tuning key
 Tune Up Oil
Colour ZFA-M = Zebra Finished Ash
Finish Matt



Original True Skin Cow Heads
 Free Ride Suspension System (patented)
 Chrome plated 4 mm traditional TTR-Rims



WB500ZFA-M

FREE RIDE SERIES (patented) FWB400 WOOD BONGOS

The MEINL FWB400 Free Ride Series Wood Bongos are the preferred bongo model by many top percussionists. Exceptional sound qualities combined with a wide variety of colours make it the perfect bongo for the working musician. The patented MEINL Free Ride System allows freely resonating bongo shells.

- Sizes** 7" Macho & 8 1/2" Hembra
Material Rubber Wood (*Hevea brasiliensis* Muell.-Arg.)
Features MEINL Free Ride Suspension System (patented)
 Chrome plated hardware
 True Skin Cow Heads
 8 mm strong tuning lugs
 3 mm rounded SSR-Rims
 Resonance Shaping Area
Includes Accessory pouch
 L-shaped tuning key
 Tune Up Oil
Colours AB = African Brown
 CR = Cherry Red
 GAB = Gold Amber Sunburst
 NT = Natural
Finish Hi Gloss



Original True Skin Cow Heads
 Free Ride Suspension System (patented)
 Chrome plated 3 mm rounded SSR-Rims
 Resonance Shaping Area



FWB400NT

FWB400CR

FWB400GAB

FWB400AB

FREE RIDE

FREE RIDE SERIES (patented) FWB300 WOOD BONGO

The MEINL FWB300 Free Ride Series Wood Bongo is equipped with traditional rims and the finest, hand selected cow heads. It produces a warm, yet full and voluminous sound. The patented MEINL Free Ride System allows the bongo shells to resonate freely.

- Sizes** 6 3/4" Macho & 8" Hembra
- Material** Rubber Wood (*Hevea brasiliensis* Muell.-Arg.)
- Features** MEINL Free Ride Suspension System (patented)
Chrome plated hardware
True Skin Cow Heads
8 mm strong tuning lugs
4 mm traditional TTR-Rims
- Includes** Accessory pouch
L-shaped tuning key
Tune Up Oil
- Colour** NT-M = Natural
- Finish** Matt



FWB300NT-M



Chrome plated 4 mm traditional TTR-Rims

FREE RIDE SERIES (patented) FWB200 WOOD BONGOS

The MEINL FWB200 Free Ride Series Wood Bongos are made from high quality components and produce a superb tone. The patented MEINL Free Ride System allows freely resonating bongo shells.

- Sizes** 6 3/4" Macho & 8" Hembra
- Material** Rubber Wood (*Hevea brasiliensis* Muell.-Arg.)
- Features** MEINL Free Ride Suspension System (patented)
Chrome plated hardware
Hand selected buffalo heads
8 mm strong tuning lugs
2.5 mm rounded SSR-Rims
- Includes** Accessory pouch
L-shaped tuning key
Tune Up Oil
- Colours** ARF = Aztec Red Fade
GAB = Gold Amber Sunburst
NT = Natural
- Finish** Hi Gloss



FWB200GAB

FWB200ARF

FWB200NT



Chrome plated 2.5 mm rounded SSR-Rims

BONGOS



WOOD BONGOS

FREE RIDE SERIES (patented) FWB190 WOOD BONGOS

The MEINL FWB190 Free Ride Series Wood Bongos are perfect for the ambitious beginner and for those who look for an affordable second set. Its professional features are outstanding in this price range. The patented MEINL Free Ride System allows freely resonating bongo shells.

- Sizes** 6 3/4" Macho & 8" Hembra
- Material** Rubber Wood (*Hevea brasiliensis* Muell.-Arg.)
- Features** MEINL Free Ride Suspension System (patented)
Black powder coated hardware
Hand selected buffalo heads
8 mm strong tuning lugs
2.5 mm rounded SSR-Rims
- Includes** Accessory pouch
L-shaped tuning key
Tune Up Oil
- Colours** CN-M = Chest Nut
CR-M = Cherry Red
GSB-M = Gold Sunburst
SNT-M = Super Natural
- Finish** Matt



FWB190GSB-M

FWB190CN-M

FWB190SNT-M

FWB190CR-M

FREE RIDE SERIES (patented) MINI WOOD BONGOS

The MEINL Mini Wood Bongo is a smaller version of a real sized bongo. It is equipped with professional features in miniature size just like the regular size standard model.

- Sizes** 3 1/2" Macho & 4 1/4" Hembra
- Material** Rubber Wood (*Hevea brasiliensis* Muell.-Arg.)
- Features** Free Ride Suspension System (patented)
True Skin Buffalo Heads
Rounded SSR-Rims
Chrome plated hardware
Tuning key
- Includes** Tuning key
- Colours** AB = African Brown
NT = Natural
R = Red
VSB = Vintage Sunburst
- Finish** Hi Gloss



FWB100AB

FWB100NT

FWB100R

FWB100VSB

FREE RIDE

FREE RIDE SERIES (patented) FFB400 FIBERGLASS BONGOS

The MEINL FFB400 Free Ride Series Fiberglass Bongos have a stunning sound reaching from powerful mids to sharp highs. Due to their fiberglass shells they are extremely durable and the perfect instrument for the working musician on the road.

- Sizes** 7" Macho & 8 1/2" Hembra
- Material** Premium fiberglass
- Features** MEINL Free Ride Suspension System (patented)
Chrome plated hardware
True Skin Cow Heads
8 mm strong tuning lugs
3 mm rounded SSR-Rims
Resonance Shaping Area
- Includes** Accessory pouch
L-shaped tuning key
Tune Up Oil
- Colours** BSP = Blue Sparkle
JBK = Jet Black
RSP = Red Sparkle
STS = Sterling Silver



Free Ride Suspension System (patented)

FREE RIDE SERIES (patented) FFB200 FIBERGLASS BONGOS

The MEINL FFB200 Fiberglass Bongos produce a compact sound with a nice spectrum of overtones. They are made from the finest components and are outstanding in quality and workmanship. Ideal for the ambitious beginner who looks for a semi-professional bongo at an affordable price.

- Sizes** 6 3/4" Macho & 8" Hembra
- Material** Premium fiberglass
- Features** MEINL Free Ride Suspension System (patented)
Chrome plated hardware
Hand selected Buffalo Heads
8 mm strong tuning lugs
2.5 mm rounded SSR-Rims
- Includes** Accessory pouch
L-shaped tuning key
Tune Up Oil
- Colours** BSP = Blue Sparkle
JBK = Jet Black
RSP = Red Sparkle
STS = Sterling Silver



BONGOS



FIBERGLASS BONGOS
BONGO BAG
BONGO STANDS

PROFESSIONAL BONGO BAG

The MEINL Bongo Bag fits all common bongo models and still has enough room for some hand percussion instruments. A padded separator is included.

- Material** Heavy duty padded nylon
- Features** Additional room for accessories
Padded shoulder strap
Carrying grip
Padded separator



MBB

PROFESSIONAL BONGO STAND (patented)

The patented MEINL Bongo Stand features a new design concept and simple functionality. The bongo is placed on a padded T-shaped tube and secured with a convenient knob screw. A stable metal clamp holds the entire unit securely in place.

- Material** Chrome plated steel
- Features** Patented design
Padded T shaped tube
Fully height- and angle adjustable
Double braced tripod legs
Fits all common bongos
- Includes** Allen wrench
Memory locks



A stable metal clamp holds the entire unit in place



TMB

PROFESSIONAL BONGO STAND (patented) FOR SEATED PLAYERS

This version of MEINL's Professional Bongo Stand (patented) has all the features of its regular model, however it can be placed low enough to be comfortably played sitting down in the traditional position. A great stand for drummers as well who incorporate a bongo into their regular drum set up.

- Material** Chrome plated steel
- Features** Seated playing position possible
Patented design
Padded T shaped tube
Fully height- and angle adjustable
Double braced tripod legs
Fits all common bongos
- Includes** Allen wrench
Memory lock



TMB-S





Orestes Vilato, USA (independent)



MIPA AWARD FOR MEINL ARTIST SERIES LUIS CONTE SIGNATURE TIMBALES

The "Musikmesse International Press Award" is annually presented by 55 music magazines from all over the world who get together and vote the best products in certain categories. The MEINL Artist Series Luis Conte Timbales won the Mipa Award in the "best percussion product" category.



DIVERSITY IN MATERIALS

MEINL has a great variety of different sounding timbales due to the diversity of materials used in making the shells. Available models include German B8 cymbal bronze, solid brass, stainless steel, black powder coated steel, chrome plated steel, and brass plated steel.



HAMMERED SHELLS

Extensively hammered shells (Artist Series Luis Conte Timbales) provide the classic dry cascara sound and support the sharpness and projection of the drums.



PATENTED FLOATUNE® TUNING SYSTEM

The patented Floatune® Tuning System works without having to drill into the shell (Artist Series Amadito Valdés and Floatune® Series timbale models). The bottom rim is positioned around the shell before the bottom is flanged. When the head is tensioned the lower rim is drawn upward against the tuning flange and the head and upper rim are drawn downward over the shell.



FLARED OUT BOTTOM EDGE

The Cuban Style flared out bottom edge increases the projection of the timbale (Artist Series Luis Conte and Professional Series Timbales).



WORKED IN FLANGES

Two flanges are worked into the shell to increase stability.



CAST BRACKETS

Brackets cast from special brass alloy (Artist Series Luis Conte and Professional Series Timbales).



PROFESSIONAL SERIES

Roland Meinl

The Roland Meinl Professional Series Timbales are made from finest German B8 cymbal bronze. They produce a fantastic warm sound with cutting rim shots and enhanced cascara playing.

- Sizes** 14" & 15"
- Material** German B8 cymbal bronze
- Features** Two worked in flanges
Cuban style flared out bottom edge
Brackets cast from special brass alloy
- Includes** Adjustable cowbell holder
Height adjustable tilting double braced tripod stand
Accessory pouch
L-shaped tuning key
Tune Up Oil



Counter sunk bolt heads
Brackets cast from special alloy

Cuban style flared out bottom edge

Made from German B8 cymbal bronze

PROFESSIONAL TIMBALE BAG

The MEINL Timbale Bag has two internal compartments (padded separator included) to fit both timbale drums (up to 15") and an outside pocket to fit the stand, cowbells, and sticks.

- Sizes** 14" & 15"
- Material** Heavy duty padded nylon
- Features** External pocket for stand and cowbell
Padded shoulder strap
Carrying grip
Padded separator



MTB



BT1415

48

ARTIST SERIES

Luis Conte

It is with the greatest appreciation and the deepest respect that we honour our friend Luis and his life's work with his MEINL Artist Series Luis Conte Signature Timbales. Perfection in even the smallest details has been achieved in this outstanding instrument. All of the specifications Luis required for his instrument have been consequently realized.

- Sizes** 14" & 15"
- Material** Solid brass or stainless steel
- Features** Extensively hammered shells
Two worked in flanges
Cuban style flared out bottom edge
Brackets cast from special brass alloy
- Includes** Adjustable cowbell holder
Height adjustable tilting double braced tripod stand
Accessory pouch
L-shaped tuning key
Tune Up Oil



LC1STS



Extensively hammered shell

Counter sunk bolt heads
Brackets cast from special alloy



LC1BRASS

49

TIMBALES



PROFESSIONAL SERIES
ARTIST SERIES
TIMBALE BAG



LUIS CONTE, USA

TIMBALES



ARTIST SERIES
FLOATUNE® SERIES
MARATHON® SERIES

ARTIST SERIES (patented)

Amadito Valdés

Amadito Valdés "the timbal magician" was born in Havana, February 14th 1946. He studied at the Havana Conservatoire with maestros Guillermo Barreto and Alfredo de los Reyes. He is the creator of a unique style of improvising on the timbales, which mixes Afro rhythms in 6/8 with the son syncopated rhythms in 2/4. Valdés has worked with all the most important Cuban big bands since the '70s and recorded countless albums with artists of the stature of Las D'Aide, Paquito Revera, Emiliane Salvador, Bebo Valdés, Las Estrellas de Areito and Peruchin. Since 1997, he has recorded and toured the globe with artists such as Juan do Marco and the Afro-Cuban-Allstars, Rubén González, Felix Baloy. He is featured in Wim Wender's famous movie Buena Vista Social Club and has also performed at the 42nd annual Grammy Awards 2000 in Los Angeles featuring Grammy Winner Ibrahim Ferrer.

The MEINL Artist Series Amadito Valdés Timbales – a tribute to one of the greatest timbaleros ever.

- Sizes** 14" & 15"
- Material** Black powder coated steel
- Features** Two worked in flanges
Patented Floatune® Tuning System
- Includes** Adjustable cowbell holder
Height adjustable tilting double braced tripod stand
Accessory pouch
Tune Up Oil



AV1BK



Patented MEINL
Floatune® Tuning
System



TI1BK

FLOATUNE® SERIES (patented)

The patented MEINL Floatune® Tuning System used on these timbales works without having to drill into the shell. The result is a voluminous timbale sound with a crisp and warm response, cutting rim shots and a great cascara sound.

- Sizes** 13" & 14"
- Material** Black powder coated steel
- Features** Two worked in flanges
Patented Floatune® Tuning System
- Includes** Adjustable cowbell holder
Height adjustable tilting double braced tripod stand
Accessory pouch
Tune Up Oil



MT1415CH

MT1415B



MARATHON® SERIES

MEINL Marathon® Series Timbales are professionally equipped yet are offered at a more affordable price. They are perfect for the working percussionist or to be included in a drum setup.

- Sizes** 14" & 15"
- Material** Steel
- Features** Two worked in flanges
Heavy duty style brackets
- Includes** Adjustable cowbell holder
Height adjustable tilting double braced tripod stand
Accessory pouch
L-shaped tuning key
Tune Up Oil
- Finish** Brass
Chrome



Adjustable cowbell
holder

DRUMMER TIMBALE MINI TIMBALE

The MEINL Drummer and Mini Timbale provide the characteristic timbale sounds and project enough to cut through any band setting. A strong mounting clamp attaches firmly to any common tom holders or L-rods. It is a perfect addition to any percussion- or drum set configuration and adds extra flavour to the groove.

- Sizes** 13" drummer timbale
8" & 10" mini timbale
- Material** Chrome plated steel
- Features** Strong mounting clamp
Original timbale brackets and tuning lugs
- Includes** L-shaped tuning key
Tune Up Oil



Strong mounting clamp
attaches to any common
L-rod



Original timbale style
brackets & tuning lugs



MDT13CH

MIT810CH



Amadito Valdés, Cuba



DIVERSITY IN MATERIALS

MEINL uses three different material to produce premium djembes: Rubber Wood (*Hevea brasiliensis* Muell.-Arg.), American White Ash (*Fraxinus americana* L.), and premium fibreglass. This diversity covers all djembe sounds ever required in any musical setting.



TRUE SKIN GOAT HEADS

The original MEINL True Skin Goat Heads on djembes offer the widest dynamic range from cutting slaps to powerful bass tones. True Skin hides are selected by specialists. After the selection process, each skin is gently tanned using a special MEINL procedure and then mounted by hand to become a first class True Skin Head.



TRUE SKIN CALF HEADS

The original MEINL True Skin Calf Heads on the MEINL Rope Tune Djembe offer an alternative sound with fewer overtones and a warmer overall spectrum. True Skin hides are selected by specialists. After the selection process, each skin is gently tanned using a special MEINL procedure and then mounted by hand to become a first class True Skin Head.



TRUE SKIN COW HEADS

The original MEINL True Skin Cow Heads on the MEINL Mother Djembe is extremely resistant and withstands even the hardest hits. They provide a full and rich sound on this huge drum. True Skin hides are selected by specialists. After the selection process, each skin is gently tanned using a special MEINL procedure and then mounted by hand to become a first class True Skin Head.



PATENTED FLOATUNE® TUNING SYSTEM

The patented MEINL Floatune® Tuning System makes drilling holes into the shell unnecessary while enhancing the resonance of the drum and increase its projection.



ROPE TUNING SYSTEM

The MEINL Rope Tune Djembe features the traditional tuning system using a resistant rope.



MOTHER DJEMBE

The MEINL Mother Djembe is the biggest djembe on the market today. It has a 21" diameter and is 42" tall. Its sound is unbelievably voluminous and rich.



It's played from the heart.
It's played from the soul.
The real inner self.

FLOATUNE® SERIES WOOD DJEMBES (patented)

The MEINL patented Floatune® Wood Djembes are modelled after the West African originals. They provide the typical traditional sounds yet equipped with modern technical innovations and features. A common drum known for its dynamic sounds and the most widely used African drum today.

- Sizes** 12" DJW3
12 3/4" DJW2
- Material** Rubber Wood (*Hevea brasiliensis* Muell.-Arg.)
- Features** True Skin Goat Heads
8 mm strong tuning lugs
3 mm rounded SSR-Rims
Easy tuning and comfortable change of heads
Rubber pads and relocated lugs offer perfect playing comfort
Patented Floatune® Tuning System
Chrome plated hardware
- Includes** Accessory pouch
L-shaped tuning key
Tune Up Oil
- Colours** AB-M = African Brown, matt
ARF = Aztec Red Fade, hi gloss
GAB = Gold Amber Sunburst, hi gloss
NT = Natural, hi gloss



The head can be tuned very simply

Special rubber pads for perfect playing comfort

Relocated tuning lugs offer perfect playing comfort

DJEMBES



DJW2GAB

DJW3AB



DJW2NT

DJW3NT



DJW2AB-M

DJW3AB-M



DJW2ARF

DJW3ARF



DJEMBES



FLOATUNE® SERIES
ROPE TUNE

FLOATUNE® SERIES FIBERGLASS DJEMBES (patented)

The MEINL patented Floatune® Series Fiberglass Djembes are truly a sound alternative. Fiberglass has enormous strength and can produce slaps of outstanding transparency and immensely powerful bass tones. This perfectly manufactured instrument is the preferred model by many top percussionists on stage and a great alternative to wooden djembes.

- Size** 12"
- Material** Premium fiberglass
- Features** True Skin Goat Heads
8 mm strong tuning lugs
3 mm rounded SSR-Rims
Easy tuning and comfortable change of heads
Rubber pads and relocated lugs offer perfect playing comfort
Patented Floatune® Tuning System
Chrome plated hardware
- Includes** Accessory pouch
L-shaped tuning key
Tune Up Oil
- Colours** BSP = Blue Sparkle
JBK = Jet Black
RSP = Red Sparkle
STS = Sterling Silver



ROPE TUNE WOOD DJEMBES

The MEINL Rope Tune Wood Djembes are crafted with great attention to detail. They feature the traditional rope tuning system. A great sounding drum at an affordable price.

- Size** 12"
- Material** Rubber Wood (*Hevea brasiliensis* Muell.-Arg.)
- Features** True Skin Calf Heads
Traditional rope tuning system
- Colours** AB-M = African Brown
NT-M = Natural
SNT-M = Super Natural
- Finish** Matt



Traditional Rope Tune System



DJEMBES



FLOATUNE® SERIES STANDS, BAGS



3 spacers to fit various djembe sizes



ST-DJEMBE

STEELY II DJEMBE STAND (patented)

The new Steely II Djembe stand (patented) features all of the same designs known from the Steely II Conga stands (patented). It can be adjusted to various djembe sizes using three spacers and is fully height adjustable. Perfect for drum circles and other street percussion activities.

- Material** Chrome plated steel
- Features** Patented designs
Metal spike attached to each leg
L-shaped legs
U-shaped notch for quick set up and breakdown
Fully height adjustable
Adapts to different djembe sizes
- Includes** Allen wrench
3 spacers

PROFESSIONAL DJEMBE STAND

The MEINL Djembe Stand was designed to firmly hold any djembe in the traditional playing position. A resistant nylon strap is placed around the drum and two rubber padded "U" shaped hooks are slide into the bottom of the shell. It can be angled and is fully height adjustable.

- Material** Chrome plated steel
- Features** Rubber padded hooks
Fully height- and angle adjustable
Double braced tripod legs
- Includes** Allen wrench
Memory lock



TMD



Length adjustable for various djembe sizes

PROFESSIONAL DJEMBE BAGS

The MEINL Djembe Bags come in two sizes medium and large to fit all common djembe models. Additional features are padded backpack straps and an external pocket for accessories.

- Sizes** Medium (up to 12")
Large (up to 13 1/2")
- Material** Heavy duty padded nylon
- Features** External pocket
Padded backpack straps
Carrying grip



FLOATUNE® SERIES WOOD DJEMBE (patented)

The MEINL patented Floatune® Wood Djembe is made from finest American White Ash (*Fraxinus Americana L.*) which produces an excellent voluminous djembe sound.

- Size** 12"
- Material** American White Ash (*Fraxinus americana L.*)
- Features** True Skin Goat Head
8 mm strong tuning lugs
3 mm rounded SSR-Rim
Easy tuning and comfortable change of heads
Rubber pads and relocated lugs offer perfect playing comfort
Patented Floatune® Tuning System
Chrome plated Hardware
- Includes** Accessory pouch
L-shaped tuning key
Tune Up Oil
- Colour** ZFA-M = Zebra Finished Ash
- Finish** Matt



DJW3ZFA-M



American White Ash (*Fraxinus americana L.*)

FLOATUNE® SERIES MOTHER DJEMBE (patented)

The patented MEINL Floatune® Mother Djembe is the biggest djembe on the market today. With its 21" diameter and 42" height it produces an extremely voluminous and powerful sound that is incomparable to any other drum today. It is perfect to be added as an additional bass drum in a percussion- or drum set up.

- Size** 21"
42" tall
- Material** Rubber Wood (*Hevea brasiliensis Muell.-Arg.*)
- Features** True Skin Cow Head
10 mm strong tuning lugs
Traditional TTR-Rim
Patented Floatune® Tuning System
Black powder coated hardware
- Includes** Accessory pouch
L-shaped tuning key
Tune Up Oil
- Colour** GSB-M = Gold Sunburst
- Finish** Matt



DJW21GSB-M



MDJB-M

MDJB-L

GLOW IN THE DARK FINISH CONGAS, BONGOS, DJEMBE

The unique "Glow In The Dark" finish is an original MEINL innovation and one-of-a-kind in today's percussion world. By applying a fluorescent layer of lacquer, the drums actually start to "glow in the dark". This results in an awesome visual effect on stage, especially in small clubs with dim lights. This finish is by far the most in demand look of today's Live Dance and Techno Scene.

SPECIFICATIONS:

MEC11GLOW	Marathon® Exclusive Series 11" Quinto, wood
MEC1134GLOW	Marathon® Exclusive Series 11 3/4" Conga, wood
MEC1212GLOW	Marathon® Exclusive Series 12 1/2" Tumba, wood
FWB400GLOW	Free Ride® Series 7" & 8 1/2" Bongo, wood
FWB100GLOW	Free Ride® Series 3 1/2" & 4 1/2" Minibongo, wood
DJW3GLOW	Hoatune® Series Djembe 12", wood

FOR MORE DETAILED PRODUCT INFORMATION SEE RELATED PRODUCT PAGES.

GLOW IN THE DARK

CONGAS, BONGOS DJEMBE



DJW3GLOW



MEC11GLOW

MEC1212GLOW

MEC1134GLOW

60

FWB100GLOW



FWB400GLOW

61

MEINL



REALPLAYER STEELBELLS

MEINL's Realplayer Steelbells are hand made using a special steel alloy. The parts are welded together in a continuous seam and sealed with a protective coating. A large variety of bells offer different pitches and sound characteristics designed to meet all musical needs.

STEEL FINISH MODELS

The pitches of these Steelbells form a diatonic scale which makes it easy to use multiple bell combinations in any musical setting.

Sizes
4 1/2" low pitch
4 1/2" medium pitch
4 1/2" high pitch
6 1/4"
8" small mouth
8" big mouth

Material Special steel alloy
Features Tonally matched
Finish Hand brushed steel



CHROME FINISH MODELS

These highly polished chrome finished models are not only visually bright, they also satisfy all of the sonic requirements for South American rhythms.

Sizes
4 1/2" low pitch
6 1/4"
8" small mouth
8" big mouth

Material Special steel alloy
Features Bright sound
Finish High polished chrome



HAND HAMMERED MODELS

The strong fundamental tone of these Steelbells make them a unique alternative to all other bells on the market. Each Steelbell has its own character.

Sizes
6 1/4"
8" big mouth

Material Special steel alloy
Features Hand hammered
Finishes Hand brushed gold
Hand brushed copper
Hand brushed steel

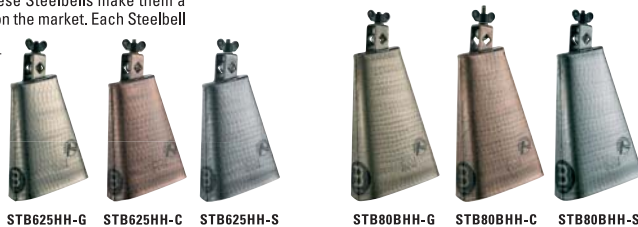

ARTIST SERIES

Kenny Aronoff

Kenny Aronoff says: "My Artist Series Signature Cowbells are the ultimate drummer's bells. Playing live they cut through and have very nice tones. Their recording characteristics are outstanding too."

Sizes
6 1/4"
8" small mouth

Material Special steel alloy
Features Hand hammered
Finish High polished chrome



HAND MODELS

These Bongo Bells easily cut through any high volume performance and are comfortable to hold. They are perfect for a classic bongo pattern.

Sizes
6.5"
7.85"
8.15"

Material Special steel alloy
Finish Hand brushed steel



SESSION LINE MODELS

The MEINL Session Line of mountable cowbells has been especially designed to meet all of the requirements of today's modern percussionists and drum set players. The black powder coating applied to those bells functions as a natural muffling and eliminates unwanted overtones yet allows the bell to cut through loud musical environments.

Sizes
4 3/4"
5 1/4"
6 1/2"

Material Special steel alloy
Features Muffled sound
Finish Black powder coated steel



PEDAL MOUNT

The MEINL Pedal Mount fits on all common bass drum pedals and firmly holds cowbells, blocks, or tambourines. It is height adjustable and contains metal spikes attached to the bottom of the legs, holding the entire unit in place without movement.

Material Black powder coated steel
Features Height adjustable legs
Metal spikes attached to the bottom of the legs
Includes 2 differently sized L-rods



COWBELL BASS DRUM HOLDER

The MEINL Cowbell Holder attaches firmly to the bass drum hoop. Rubber pads prevent scratches on the hoop.

Material Chrome plated steel
Features Fully adjustable
Rubber pads against scratching
Includes L-shaped rod

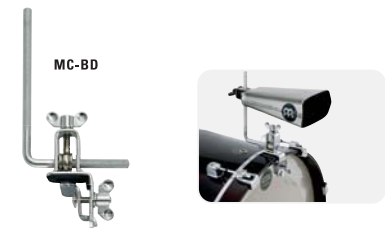

COWBELL BEATERS

MEINL offers a regular and professional cowbell beater for more sound options.

Material Rubber Wood (*Hevea brasiliensis* Muell.-Arg.)
Features Ribbed grip
Padded beater section



HANDMATE

The MEINL Handmate is a professional cowbell beater which can be mounted in a setup. This allows hitting the cowbell by hand while playing another instrument.

Material Steel construction with a wooden ball
Features Fully adjustable





CHIMES

MEINL Chimes provide great tonal diversity and are available in a wide assortment of sounds. Percussionists and drum set players will find various chime models to fit any application. All MEINL Chimes are made from a premium anodized aluminum alloy, and a well balanced wooden bar. A durable nylon cord is used to attach them firmly together.

ARTIST SERIES

Luis Conte

"I wanted a wide spectrum!" comments Luis Conte. "The shorter bars deliver great high pitched sounds. I can get a full and bright chime sound from the medium and low pitched bars. They sound perfect especially in the studio."

Size 60 bars, double row
Material Silver anodized aluminum alloy
Features High frequency chime
Includes Holder
 Striker



LC60HF

CHIMES, 66 BARS

The 66 bar chimes produce a rich and full sound. They cut through any band setting.

Size 66 bars, double row
Material Gold anodized aluminum alloy
Features High frequency chime
Includes Holder
 Striker



CH66HF

CHIMES, 36 BARS

With bars made from hand polished aluminum, these chimes produce a sound that is clear, bright, and rich in volume and expression.

Size 36 bars, single row
Material Hand polished aluminum alloy
Includes Holder
 Striker



CH36

NEW

CHIMES, 33 BARS

The 33 bar chimes produce a very bright sound with a pronounced upper overtone spectrum. They are perfect for all live situations.

Size 33 bars, single row
Material Gold anodized aluminum alloy
Features High frequency chime
Includes Holder
 Striker



CH33HF

ROCK CHIMES, 33 BARS

The bars of MEINL Rock Chimes are thicker for a richer and more voluminous sound.

Size 33 bars, single row
Material Gold anodized aluminum alloy
Features High frequency chime
Includes Holder
 Striker



CH33HF-R

CHIMES, 27 BARS

The 27 bar chimes produce a full sound with a wide tonal spectrum. Ideal for smaller stages and club scenes.

Size 27 bars, single row
Material Gold anodized aluminum alloy



CH27

STUDIO CHIMES, 27 BARS

The Studio Chimes feature slightly thinner bars for a full, rich and tasteful sound.

Size 27 bars, single row
Material Gold anodized aluminum alloy



CH27ST



All trusses are made from Jamjuree Wood. All bars are attached through a twisted nylon cord.

CHIMES, 12 BARS

The 12 bar chimes produce a beautiful, high pitched sound. Not too obtrusive, ideal for tasteful chime accents.

Size 12 bars, single row
Material Gold anodized aluminum alloy



CH12

CHIMES HOLDERS

These two differently sized MEINL holders comfortably place the chimes within a drum or percussion set up.

Sizes Regular
 Large
Material Chrome plated steel
Features Knurled surface
 Foam washer



MC-CH

MC-CHL

PROFESSIONAL CHIMES BAG

The MEINL Chimes Bag fits all common chime models and is the perfect solution for transporting these valuable and fragile instruments. Inner velcro straps hold the instrument in place while two internal pockets secure them.

Material Heavy duty padded nylon
Features Stores up to 2 chimes
 Carrying grip
 Inner velcro straps
 2 internal pockets



2 internal pockets with inner velcro straps

MCHB





HAND CHIMES

The three differently sized models of these hand chimes are tonally matched. They can easily be played by hand only and still produce a full and rich sound.

- Sizes** 12 bars
18 bars
24 bars
- Material** Gold anodized aluminum alloy

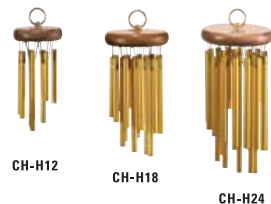

CH-H12

CH-H18

CH-H24

PEG CHIME

The Peg Chimes are extremely high pitched. They are perfect for special accents.

- Size** 12 pegs
- Material** Gold plated steel



CH-HPEG

TRI TONE CHIMES

The three free floating bars create a very long sustain and are tonally matched.

- Material** Gold anodized aluminum alloy
- Features** Mountable on all common L-rods
- Includes** Wooden beater
Holder



CH3

TRIANGLES

The solid brass triangles produce a nice sounding soft tone with a controlled sonic spectrum.

- Sizes** 4"
6"
8"
- Material** Solid brass
- Includes** Wooden holder with braided nylon cord
Metal beater

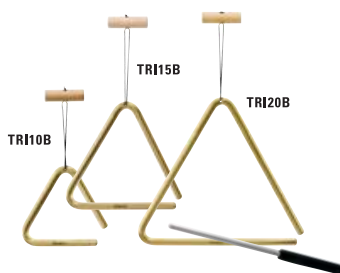

TRI10B

TRI15B

TRI20B

TRIANGLE HOLDER

The MEINL Triangle Holder is a simple but effective way to place the triangle in the percussion set up.

- Material** Chrome plated steel
- Features** Knurled surface
Nylon cord



MC-TRI

WOOD TAMBOURINES

MEINL's Wood Tambourines are made from a sturdy frame with jingles available in different materials, resulting in various sound possibilities. Their ergonomically shaped handle and light weight enable energetic playing.

WOOD TAMBOURINES, STEEL JINGLES

Featuring 1 or 2 row versions. The MEINL Wood Tambourines with nickelsilver plated steel jingles produce a bright sound that projects well.

- Sizes** 1 row
2 rows
- Material** Jingles: Nickelsilver plated steel
Wooden frame
- Colour** AB = African Brown



TA1AB

TA2AB

WOOD TAMBOURINES, BRASS JINGLES

Featuring 1 or 2 row versions. Solid brass jingles deliver a distinctively warm, and cutting sound.

- Sizes** 1 row
2 rows
- Material** Jingles: Solid brass
Wooden frame
- Colour** AB = African Brown



TA1B-AB

TA2B-AB

WOOD TAMBOURINES, ALUMINUM JINGLES

Featuring 1 or 2 row versions, the MEINL Wood Tambourines with aluminum jingles deliver a very soft and harmonic sound. They are also light weight for extensive and energetic playing.

- Sizes** 1 row
2 rows
- Material** Jingles: Aluminum
Wooden frame
- Colour** AB = African Brown



TA1A-AB

TA2A-AB



ABS TAMBOURINES

MEINL Hand and Set Up Tambourines (design protected by a utility model) have a distinct design advantage due to the construction of the ABS frame. Unlike other tambourines, MEINL's utilizes several different part in the frame which are assembled into a type of "sandwich". This results in unsurpassed durability. Due to their shape and ergonomical design the tambourines are perfectly balanced and outstanding in sound and quality. A wide range with different type jingles is available for all sound applications.



A "Guiro" kind of sound can also be produced by scraping the ribbed edge of the frame
Padded soft grip for more playing comfort

TAMBOURINES, STEEL JINGLES

These ergonomically shaped tambourines are available as hand held or mountable versions. The durable ABS frame allows hard hitting and energetic hand playing. Nickelsilver plated steel jingles produce a bright sound that projects well.

- Material** Jingles: Nickelsilver plated steel
Frame: ABS
- Features** Padded soft grip for more playing comfort
Ergonomic design
Available as hand held or mountable versions
Guiro style playing surface
"Sandwich" construction
- Colours** BK = Black
R = Red



Steel jingles produce a bright sound that projects well



TAMBOURINES, BRASS JINGLES

The MEINL Brass Tambourines are ergonomically shaped and available as hand held or mountable versions. The durable ABS frame allows hard hitting and energetic hand playing. They deliver a very warm, yet cutting sound.

- Material** Jingles: Solid brass
Frame: ABS
- Features** Padded soft grip for more playing comfort
Ergonomic design
Available as hand held or mountable versions
Guiro style playing surface
"Sandwich" construction
- Colours** BK = Black



Solid brass jingles produce a very warm, yet cutting sound



TAMBOURINES, ALUMINUM JINGLES

The MEINL Aluminum Tambourines are available as hand held or mountable version. The hand held version is extremely light weight for extensive and energetic playing. The mountable version is built to resist hard hitting. Both versions' sound is very soft and harmonic.

- Material** Jingles: Aluminum
Frame: ABS
- Features** Padded soft grip for more playing comfort
Ergonomic design
Available as hand held or mountable versions
Guiro style playing surface
"Sandwich" construction
- Colours** B = Blue
WH = White (hand held only)



Aluminum jingles produce a very soft and harmonic tone



TAMBOURINE HOLDER

The tambourine holder converts a MEINL Hand Held Tambourine into a set up tambourine. It holds it in place and is made to resist even the hardest hits.

- Material** Chrome plated steel
- Features** Rubber pads against scratching
Padded surface against rattling



JINGLE STICKS

MEINL Jingle Sticks create many interesting sound possibilities. Available are models with jingles made from nickelsilver plated steel, solid brass, or aluminum for many sound applications.

- Jingles** Nickelsilver plated steel
Solid brass
Aluminum
- Features** Padded grip
Guiro style playing surface



GUIROS BLOCKS



PLASTIC GUIRO

The MEINL Plastic Guiro is precision molded from high strength plastic. It features three different striking surfaces and rubber ringed grip holes for maximum comfort and control. It has a slightly dryer and warmer sound than the fiberglass model, yet brighter and louder than a natural gourd guiro.

Material High strength plastic
Features Three striking surfaces
 Rubber ringed grip holes
Includes Plastic Scraper
Colour BK = Black



GU6BK

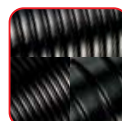

3 playing surfaces

FIBERGLASS GUIROS

The MEINL Fiberglass Guiro has become extremely popular among percussionists worldwide. It offers three different striking surfaces for enhanced sounds and rubber ringed grip holes.

Material Premium fiberglass
Features Three striking surfaces
 Rubber ringed grip holes
Includes Plastic scraper
Colours BK = Black
 R = Red



GU7R

GU7BK

WOOD GUIROS

The traditional MEINL Wood Guiros are available in two different versions and produce a warm and cutting sound. With their two grip holes, they are very easy and comfortable to play.

Material Wood
Features Three striking surfaces
 Grip holes
Includes Plastic scraper
Colour AB-M = African Brown
Finish Matt



NEW

GU2AB-M

GU1AM

Material Wood
Features Grip holes
Includes Wooden scraper
Colour AM = Amber

GUIRO HOLDER

The MEINL Guiro Holder firmly attaches to any common rod and holds the guiro securely in place while it is played.

Material Chrome plated steel
Features Rubber pads against scratching



MC-GU

PERCUSSION BLOCKS, HIGH PITCH

The MEINL Percussion Block is made to withstand even the hardest players. It delivers a cutting high pitched sound and is easily mounted on any conventional L-rod.

Material PE
Features High pitched sound
 Durable
Includes Mounting Clamp
Colours BK = Black
 R = Red



MPE1R

MPE1BK

PERCUSSION BLOCKS, LOW PITCH

The MEINL Percussion Block is made to withstand even the hardest players. It delivers a low pitched sound and is easily mounted on any conventional L-rod.

Material PE
Features Low pitched sound
 Durable
Includes Mounting Clamp
Colours BK = Black
 R = Red



MPE2R

MPE2BK

WOOD BLOCKS

The two versions of the MEINL Wood Blocks are tonally matched, highly durable and produce voluminous sound with wood accents. Ideal for keeping time.

Sizes Small
 Large
Material Rubber Wood (*Hevea brasiliensis* Muell.-Arg.)
Features Rounded playing surface
Includes Wooden beater



MWB1

MWB2

WOOD BLOCK HOLDER

A special holder is available to include the MEINL Wood Blocks into any drum- or percussion set up. It can be fixed to any common L-rod.

Material Chrome plated steel



MWBH1

SHAKERS

ALUMINUM SHAKERS, OCTAGONAL

MEINL's Octagonal Aluminum Shakers come in three different sizes. All of them have a broad dynamic range with lots of volume.

Sizes Small
Medium
Large
Material Aluminum
Colour BK = Black



ALUMINUM JINGLE SHAKER

The MEINL Jingle Shaker (designed by Juan Carlos Melian) has two pairs of steel jingles which are attached in one row to an octagonal aluminum shaker. The effect and possibilities of this idea are enormous: Start off by playing the shaker with the jingles facing up. By tilting the shaker 90° to the front, the jingles will start to click on the beat. And by simply tilting the shaker 90° back, the jingles will start to click off the beat. This gives one the ability to completely change the feel of a song instantly by a simple twist of the wrist.

Size Medium
Material Shaker: Aluminum
Jingles: Steel
Colour BK = Black



ALUMINUM SHAKERS, ROUND

The MEINL Round Aluminum Shakers were designed to cut through loud live music. They have a distinctive sound with a great tonal range. Available are two different versions: A single shaker, and a double shaker for a louder shaker sound.

Size Large
Material Anodized aluminum
Features Available as a single, or double shaker
Colour S = Silver



STUDIO SHAKER

MEINL's Studio Shaker was designed to meet all the requirements necessary in today's session world. It is light weight and therefore very comfortable to play. It delivers a very tasteful and delicate shaker sound with a warm overall tone and a very well balanced frequency spectrum.

Size Large
Material Plastic
Colour BK = Black



FIBERGLASS SHAKERS

These MEINL Shakers are made from premium fiberglass for more durability and better sound quality. They are light weight and very comfortable to play.

Sizes Medium
Large
Material Premium fiberglass
Colour BK = Black

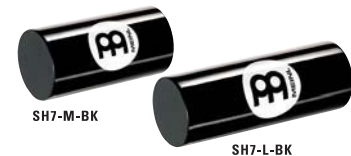

SHAKER HOLDER

The MEINL Shaker Holder (designed by Jen Lowe) firmly attaches to any common rod. With its length adjustable specially shaped claws it holds any size shaker in a comfortable position for quick reach.

Material Chrome plated steel
Features Rubber pads against scratching
Length adjustable
Strong mounting clamp



SKIN SHAKERS

The MEINL Skin Shakers combine two different materials into one unique instrument. They produce very experimental sounds and work perfectly in modern music productions.

Sizes Small
Medium
Material Plastic with natural skin side caps
Colour BK = Black

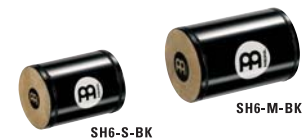

ARTIST SERIES

The two versions of the MEINL Artist Series Shakers have been designed according to master percussionist Luis Conte's (Phil Collins) exact requirements. "My shaker sound is as smooth as silk" is how Luis described their sound when he played them for the first time. Two different versions are available: The Studio Shaker with a very subtle and smooth tone, and Luis' Live Shaker which has a more voluminous, yet delicate sound.

Size Medium
Material Plastic
Features Two individual shakers connected as one instrument
Colours Live Shaker: BK = Black
Studio Shaker: R = Red



FIBERGLASS MINI SHAKERS

The MEINL Mini Shakers are made from premium fiberglass and offer a smooth and soft shaker sound which blends well with all music and always delivers the right accents.

Sizes Medium
Large
Material Premium fiberglass
Colour R = Red



FIBERGLASS JINGLE MINI SHAKERS

The MEINL Fiberglass Mini Shakers features a pair of aluminum jingles which are attached to the shaker and add an additional flavour to its sound.

Sizes Medium
Large
Material Premium fiberglass
Features Additional jingles
Colour R = Red



DOUBLE SHAKER

The MEINL Double Shaker is woven by hand and includes a coconut bottom for increased projection. It offers two different sounds in one instrument.

Material Rattan with coconut bottom



GANZAS

MEINL Ganzas are available in two sizes and are woven by hand with a coconut bottom. They offer a great alternative to conventional shakers.

Sizes Medium
Large
Material Rattan with coconut bottom



CAXIXIS

The MEINL Caxixis are available in three different sizes for an enhanced tonal range and woven by hand with a coconut bottom. Their sound is crystal clear, high pitched with a great projection.

Sizes Small
Medium
Large
Material Rattan with coconut bottom



SHAKERS, CAXIXIS, GANZAS, DOUBLE SHAKER



SKIN MARACAS

The MEINL Skin Maracas are entirely made by hand and are offered in four different sizes for a wide sonic range. The two larger models sound especially full and dry, whereas the smaller sized versions produce a very tight and high pitched sound.

Sizes Mini
Midi
Traditional
Jumbo
Material Natural skin
Wooden handle



Tanja Hafenstein, Australia: "MEINL offers a large variety of great sounding Maracas. They are applicable in any style of music from traditional Rumba to modern Pop and R&B."

PLASTIC MARACAS

The MEINL Plastic Maracas produce a loud and crisp sound. They are very durable and comfortable to play.

Material Plastic
Wooden handle



PLASTIC MARACAS

Material Plastic
Colours B = Blue
BK = Black
Y = Yellow



WOOD MARACAS

The traditional MEINL Wood Maracas are available in both round and oval models. Both of these exhibit a traditional warm and rich sound.

Material Wood



WOOD EGG SHAKERS

The MEINL Wood Egg Shakers are turned from wood and deliver a soft yet rich sound. They are perfect in situations which require clearly defined accents.

Size Jumbo
Material Wood
Colours AM = Amber
BK = Black
R = Red



PLASTIC EGG SHAKERS

The MEINL Plastic Egg Shakers are preferred due to their smooth and crystal clear sound. These have applications in practically any musical setting.

Material Plastic
Colours B = Blue
BK = Black
GREEN = Green
R = Red
Y = Yellow

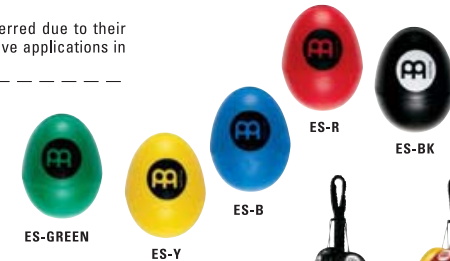

BIRDS / WATERFALL

The MEINL Birds and Waterfall realistically imitate the sound of a flock of birds or a rippling waterfall. By using fiberglass a bright sound is produced, the dynamic range is increased and an optimum durability is realized.

Material Premium fiberglass
Features Durable cord



MARACAS, EGG SHAKERS, BIRDS



**CABASAS, SHEKERES,
KOKIRIKO, THE ROAR,
THE NIGHT**



CABASAS, WOOD

The MEINL Wood Cabasas are available in three different sizes and produce a clear and voluminous sound. Made from high quality components, it is very durable and long lasting.

- Sizes** Small
Regular
Large
- Material** Steel chain and stainless steel cylinder
- Colour** AM = Amber

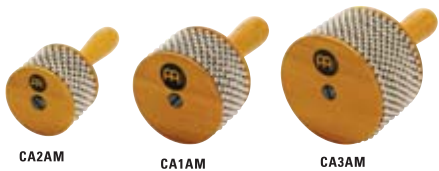

CABASA, WOOD WITH SOFT GRIP

The most common wood cabasa model is offered with a padded soft grip for a more comfortable playing feel.

- Size** Regular
- Material** Steel chain and stainless steel cylinder
- Colour** CR = Cherry Red



CABASA, FIBERGLASS

The shape and function of the MEINL Fiberglass Cabasa equals a traditional gourd calabash. The MEINL fiberglass version however offers positive stability and dynamic sound quality.

- Material** Premium fiberglass
- Colour** R = Red



SHEKERE

The MEINL Shekere is handmade from premium fiberglass and fitted with a net of synthetic pearls. It delivers a rich, full sound and unlike gourd shekeres it is nearly unbreakable.

- Material** Premium fiberglass
- Colour** BK = Black



SHEKERE, JUMBO SIZE

MEINL's Jumbo Size Shekere is hand made from premium fiberglass and fitted with a net of synthetic pearls. Because of its large body size it produces a wide tonal range of sounds ranging from low bass tones when struck on the bottom to loud, high pitched shaker and rattle sounds.

- Material** Premium fiberglass
- Colour** VSB = Vintage Sunburst



CABASA HOLDER

This unique attachment holds the cabasa safe and ready to use. The padded surface prevents it from slipping.

- Material** Chrome plated steel
- Features** Strong mounting clamp
Padded surface



THE ROAR

The MEINL Roar is available as a wood and as a fiberglass version. A rattling effect is achieved by striking the ball end against the palm of the hand. The wood version produces a warm crisp tone whereas the fiberglass version delivers a dryer and louder sound.

- Material** Wood or premium fiberglass
- Features** Solid construction



KOKIRIKO

The Kokiriko originated in Japan as a sound effect instrument. It produces a rattling effect which can be an almost silent rustling to an extremely loud chatter.

- Material** Wood
- Features** Ergonomically shaped handle
Durable cord
- Colour** AM = Amber



THE NIGHT

When playing The Night, four solid steel balls hit a cylindrical metal rod in quick succession producing the unique sound of crickets.

- Material** Solid steel balls and cylinder
Wooden body
- Features** Ergonomically shaped handle
- Colour** AM = Amber



**CLAVES,
PERCUSSION TABLES,
STANDS**



WOOD CLAVES, CLASSIC

The MEINL Classic Wood Claves are the most common claves and produce the classic cutting sound. Both the clave and the striker have the same size.

- Material** Hardwood
Redwood
- Features** Solid body



FIBERGLASS CLAVES

The MEINL Fiberglass Claves produce the most penetrating, loud, and cutting sound of all. It is hand made from premium fiberglass which makes it nearly indestructible.

- Material** Premium fiberglass
- Features** Solid body
Cutting sound
- Colour** R = Red



POCKET CLAVES

The MEINL Pocket Claves are made from a hard, resistant wood which produces a very cutting and penetrating sound. Due to their small size they are handy and convenient but still deliver a solid rhythmic foundation in a band setting.

- Size** 6 3/4" long
- Material** Hardwood
- Features** Cutting sound
Convenient carrying



WOOD CLAVES, AFRICAN

African Claves are slightly larger and have a lower fundamental pitch. Additionally, the resonating body is larger than the striker. Available in two different versions: Solid- and hollowed out body.

- Material** Hardwood
Redwood
- Features** Solid body
Hollowed out body



PERCUSSION TABLES

The MEINL Percussion Tables are made from durable fiberglass and offer enough room for all common hand percussion instruments. It can be attached to all common stands. Through its innovative design the angle of the table can be adjusted.

- Sizes** 18" x 12"
12" x 12"
- Material** Premium fiberglass
- Features** Carpeted anti slipping surface
Adjustable angle
Strong mounting clamp



PERCUSSION STAND

The MEINL Percussion Stand is a universal device which offers a variety of set up solutions for both drummers and percussionists. It is fully height adjustable and features both quick locks and memory locks for a quick set up.

- Material** Chrome plated steel
- Features** Height adjustable
Double braced tripod legs
- Includes** Allen wrench
Memory locks
2 straight rods
2 angled rods
2 Z-shaped rods

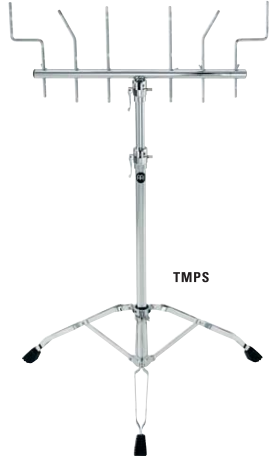

PERCUSSION TABLE STAND

The MEINL Percussion Table Stand offers enough room for all common hand percussion instruments. It is fully height adjustable and has a carpeted anti slipping surface.

- Size** 16" x 22"
- Material** Table: Premium fiberglass
Stand: Chrome plated steel
- Features** Carpeted anti slipping surface
Fully height adjustable
Double braced tripod legs
- Includes** Allen wrench
Memory lock



All MEINL Tripod Stands are equipped with memory- and quick locks





ORIGINAL MEINL HARDWARE

A professional mounting system requires stability and flexibility. The Original Meinl Hardware features the highest quality workmanship to provide a large variety of set up solutions for both percussionist and drummers alike. A system of well thought out clamps, holders, rods, and attachments for literally any set up or space situation.

MULTI CLAMP, ONE MOUNT

The MEINL Multi Clamp easily attaches to any common stand. Its unique feature is the length adjustability to fit any given space situation. It holds one rod.

Material Chrome plated steel
Features Length adjustable
 Strong mounting clamp
Includes Straight rod



Length adjustability for more flexibility

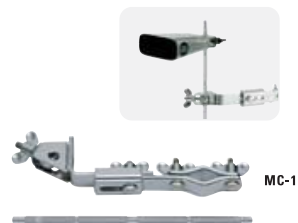

MC-1

MULTI CLAMP, TWO MOUNT

The MEINL Multi Clamp easily attaches to any common stand. Its unique feature is the length adjustability to fit any given space situation. It holds two rods.

Material Chrome plated steel
Features Length adjustable
 Strong mounting clamp
Includes 2 straight rods

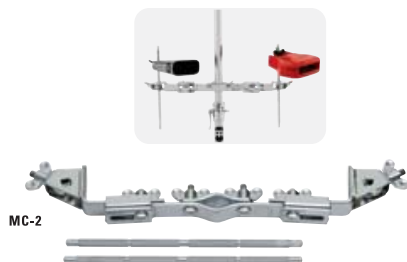

MC-2

MULTI CLAMP, FOUR MOUNT

The MEINL Multi Clamp easily attaches to any common stand. Its unique feature is the length adjustability to fit any given space situation. It holds four rods.

Material Chrome plated steel
Features Length adjustable
 Strong mounting clamp
Includes 2 straight rods
 2 angled rods

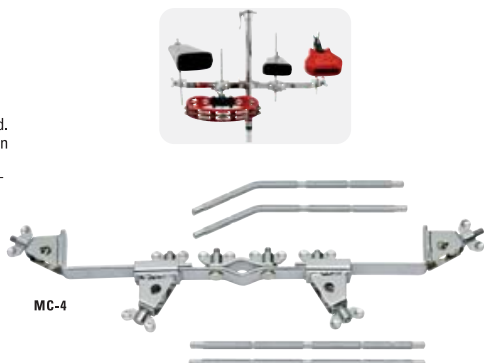

MC-4

CLAMP

The MEINL Percussion Clamp attaches to the lug of a conga, bongo, or djembe for mounting an additional cowbell, block, or tambourine.

Material Chrome plated steel
Features Compact and solid design



CLAMP

MOUNTING BAR, 6 PCS.

The MEINL Mounting Bar can easily be attached to any stand. It's ideal for expanding your percussion or drum set up.

Material Chrome plated steel
Includes 2 straight rods
 2 angled rods
 2 Z-shaped rods

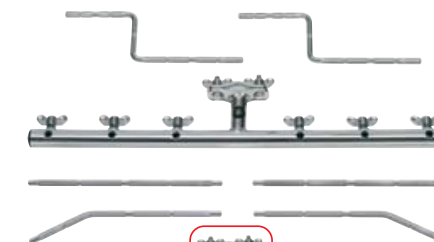
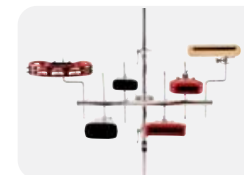

PMC-6



Strong mounting clamp

RODS

A variety of differently shaped rods can hold several mountable hand percussion instruments.

Shape Straight rod
 Angled rod
 Z-shaped rod
Material Chrome plated steel
Features Knurled surface

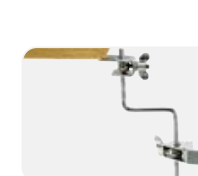

MC-R3

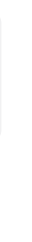

MC-R1



MC-R2

SAMBA SERIES

The MEINL Samba Series is a line of innovative Brazilian Percussion Instruments. Its variety of different and authentic sounds combined with light weights for comfortable playing makes this series invaluable to all percussionists.

ALUMINUM REPINIQUES

The Repinique is played with a stick while the other hand is used for open tones and slaps. MEINL offers two sizes made from premium aluminum.

- Sizes** 10" x 10"
12" x 12"
- Material** Aluminum
- Features** Counter sunk bolt heads
Chrome plated hardware
Replaceable synthetic heads
6 tuning lugs (10" model)
8 tuning lugs (12" model)
- Includes** Tuning key



Counter sunk bolt heads



NEW

RE10

RE12



NEW

RE12AB

WOOD REPINIQUE

For an especially warm and harmonic sound, MEINL offers a Repinique made from wood.

- Size** 12" x 10"
- Material** Rubber Wood
(*Hevea brasiliensis* Muell.-Arg.)
- Features** Counter sunk bolt heads
Chrome plated hardware
Replaceable synthetic heads
8 tuning lugs
- Includes** Tuning key
- Colour** AB = African Brown
- Finish** Hi Gloss

PROFESSIONAL REPINIQUE BAGS

The MEINL Repinique Bags are made from heavy duty padded nylon with reinforced stitching and are equipped with a double-slide zipper, a shoulder strap, and a carrying grip. They protect your instruments and provide hassle free transportation.

- Sizes** 10" x 10"
12" x 12"
- Material** Heavy duty padded nylon
- Features** Double-slide zipper
Shoulder strap
Carrying grip
External pocket



MREB-12

MREB-10



SB-R

NEW

SAMBA BELT

MEINL offers a high quality belt to ensure a safe and comfortable playing of the Surdo and Repinique. It can be placed around the player's shoulder or hip depending on the required playing position.

- Material** Cotton
- Features** Length adjustable
Adjustable shoulder padding
Strong attachment hooks
- Colour** R = Red

SURDOS

The deep sound of the Surdo is the heartbeat of Samba Music. It is played with a felt beater. MEINL offers several sizes made from premium aluminum.

- Sizes** 18" x 22"
20" x 24"
22" x 24"
- Material** Aluminum
- Features** Counter sunk bolt heads
Chrome plated hardware
Replaceable synthetic heads
8 tuning lugs (18" model)
10 tuning lugs (20" & 22" models)
- Includes** Tuning key



NEW

NEW

SU22

SU18

SU20



NEW

NEW

NEW

PROFESSIONAL SURDO BAGS

The MEINL Surdo Bags are made from heavy duty padded nylon with reinforced stitching and are equipped with a double-slide zipper, padded backpack straps, and a carrying grip. They protect your instruments and provide hassle free transportation.

- Sizes** 18" x 22"
20" x 24"
22" x 24"
- Material** Heavy duty padded nylon
- Features** Double-slide zipper
Padded backpack straps
Carrying grip
External pocket



Padded backpack straps

MSUB-22

MSUB-20

MSUB-18

PANDEIROS

The Pandeiro is played with one hand while the other alters the pitch of the drum. Solid jingles produce a brilliant and cutting sound.

- Sizes** 10"
12"
- Material** Rubber Wood (*Hevea brasiliensis* Muell.-Arg.)
- Features** Counter sunk bolt lugs
Chrome plated hardware
Replaceable hand selected goat heads
- Includes** Tuning key
- Colour** CN-M = Chest Nut
- Finish** Matt



Solid jingles produce a brilliant and cutting sound



PA10CN-M

PA12CN-M

PROFESSIONAL PANDEIRO BAGS

The MEINL Pandeiro Bags are made from heavy duty padded nylon with reinforced stitching and are equipped with a double-slide zipper and a shoulder strap. They protect your instruments and provide hassle free transportation.

- Sizes** 10"
12"
- Material** Heavy duty padded nylon
- Features** Double-slide zipper
Shoulder strap
External pocket



MPAB-12
NEW

MPAB-10
NEW

FLOATUNE® TAMBORIMS (patented)

Tamborims are played with a plastic stick while the other hand changes the pitch of the drum. It has a bright, loud, and cutting sound. MEINL offers a variety of tamborims all made from several high quality materials for more sound options.

- Size** 6"
- Material** ABS
Aluminum
Brass plated steel
Chrome plated steel
Rubber Wood (*Hevea brasiliensis* Muell.-Arg.)
- Features** Patented Floatune® Tuning System
Counter sunk bolt lugs
Replaceable synthetic heads
- Includes** German "Pfenning" as tuning key



Patented Floatune® Tuning System



TBR06ALU

TBR06SNT-M

TBR06ABS-BK

TBR06CH

TBR06B NEW

TBR06ABS-R NEW

TBR06ABS-GR NEW

TBR06ABS-Y NEW

TAMBORIM STICKS

- Material** Plastic
- Colours** BK = Black
R = Red



TBR06R

TBR06BK

PROFESSIONAL TAMBORIM BAG

The MEINL Tamborim Bag is made from heavy duty padded nylon with reinforced stitching and is equipped with a double-slide zipper and a shoulder strap. It protects your instruments and provides hassle free transportation.

- Size** 6"
- Material** Heavy duty padded nylon
- Features** Double-slide zipper
Shoulder strap
External pocket



Perfect Fit



MTAB-06

SAMBA SERIES



HANDHELD MODELS

The unique feature of the MEINL Handheld Models is a wide and comfortable grip. Ideal for street percussion.

- Sizes** 4 1/2"
6 1/4"
- Material** Special steel alloy
- Features** Comfortable holder
- Finish** Hand brushed steel



STB45HA-CB STB625HA-CB

A-GO-GO STEEL FINISH MODELS

These MEINL A-Go-Go Bells are tonally matched especially for the requirements of South American rhythms.

- Sizes** Small
Large
- Material** Special steel alloy
- Includes** Mounting clamp for small model
- Finish** Hand brushed steel



STBAG1 STBAG2

A-GO-GO CHROME FINISH MODELS

These highly polished A-Go-Go Bells offer a bright sound and are equipped with a flexible connection. Ideal for Samba style music.

- Sizes** Small
Large
- Material** Special steel alloy
- Feature** Flexible connection
- Finish** High polished chrome



STBAG4-CH STBAG2-CH

HANDHELD MODELS, ALUMINUM

Another true MEINL innovation! They are the perfect handheld bells for Samba Music due to their light weight and comfortable grip which keeps the player from tiring, allowing for energetic playing. Aluminum also enables a more soft and musical tone.

- Sizes** 4 1/2"
6 1/4"
- Material** Aluminum
- Features** Light weight construction
Comfortable rectangular grip



STB45HA-ALU STB625HA-ALU

FLOATUNE® QWEEKA

The playful sound of the Qweeka originates in Brazil – the land of the Samba. While one hand rubs the internal bamboo shaft with a moist cloth, the other hand controls the pressure of the head thereby changing the pitch of the tone.

- Size** 8"
- Material** Premium fiberglass
- Features** Floatune® Tuning System
Hand selected goat head
Tuning key
- Includes** R = Red
- Colour**



QW7R

SAMBA SHAKERS

The MEINL Samba Shakers are the ideal instruments for Street Samba due to their voluminous sound and their ability to cut through loud musical environments. Their shells are made from thin aluminum which, when combined with solid steel shots, produce a warm, penetrating, and cutting shaker sound.

SINGLE SHAKERS NEW

- Sizes** Small
Medium
Large
- Material** Aluminum

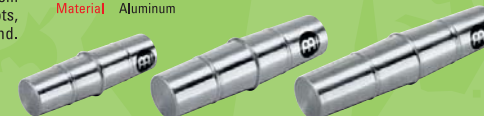

SSH1-S SSH1-M SSH1-L

DOUBLE SHAKERS NEW

- Sizes** Small
Medium
Large
- Material** Aluminum



SSH2-S SSH2-M SSH2-L

TRIPLE SHAKERS NEW

- Sizes** Small
Medium
Large
- Material** Aluminum

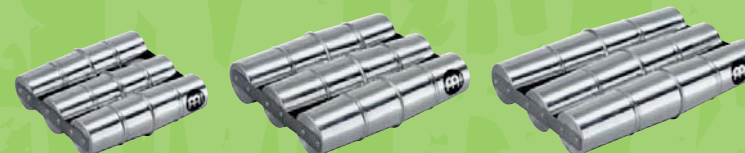

SSH3-S SSH3-M SSH3-L

SAMBA STICKS NEW

MEINL offers a wide assortment of Samba Sticks for Tamborims and Repiniques in order to achieve their authentic sounds. All sticks are made from high quality materials and ensure a comfortable playing.

- Material** Plastic
- Features** Stick, long version
Stick, regular version
Triple stick
Sevenfold stick



SST1-R SST1-L SST3 SST7

SAMBA BEATERS NEW

MEINL offers a wide assortment of Samba Beaters for Surdos and Repiniques in order to achieve their authentic sounds. All beaters are made from high quality materials and ensure a comfortable playing.

- Features** 15" long, aluminum stick with 2" felt beater
16" long, wood stick with 2" felt beater
16" long, wood stick with 2 1/2" felt beater
16" long, wood stick with 2" leather beater
16" long, wood stick with 3" bushy felt beater



SB1 SB2 SB3 SB4 SB5



CAJONS CAJON BAG



CAJONS

The MEINL Cajons are completely hand made from start to finish. They work perfectly for Flamenco or World Music and deliver an extremely wide range of sounds, reaching from loud, deep bass tones up to cutting overtones with an abundance of projection and enforcement. Both percussionists and drummers appreciate the Cajon for its diversity of sound. They also work perfectly during unplugged gigs or sessions.

Once again, MEINL proves its leading position in developing innovative instruments in today's percussion world: The CAJ1 and CAJ2 Cajons combine features such as adjustable snare wires, which up to now have never been utilized in any other Cajon. Also, the top corners of the front plate can be adjusted, allowing the player to customize the amount of snap desired.

Material Frontplate: American White Ash (*Fraxinus americana* L.)
Resonating body: Rubber Wood (*Hevea brasiliensis* Muell.-Arg.)
Features Adjustable top corners
Internal, adjustable snare wires
Padded sitting surface
Wide sound options
Finish Matt



Fully adjustable snare wires



Internal snare wires

Material Frontplate: American White Ash (*Fraxinus americana* L.)
Resonating body: American White Ash (*Fraxinus americana* L.)
Features Adjustable top corners
Internal, adjustable snare wires
Padded sitting surface
Wide sound options
Finish Matt



CAJ1SNT-M



CAJ2AWA-M

MEINL also offers a high quality Peruvian Cajon with a built in sizzle effect. The top corners of the frontplate can be adjusted, allowing the player to customize the amount of snap desired.

Material Frontplate: Makah-Burl Wood
Resonating body: Rubber Wood (*Hevea brasiliensis* Muell.-Arg.)
Features Built in sizzle effect
Padded sitting surface
Wide sound options
Includes Allen wrench
Finish Matt



Makah-Burl Wood

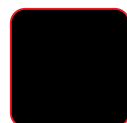

Premium fiberglass



CAJ3MB-M

Material Frontplate: Premium fiberglass
Resonating body: Rubber Wood (*Hevea brasiliensis* Muell.-Arg.)
Features Built in sizzle effect
Padded sitting surface
Wide sound options
Includes Allen wrench



CAJ7NT-BK

PROFESSIONAL CAJON BAG

The MEINL Cajon Bag is the perfect solution for transporting these valuable and fragile instruments. Its heavy duty padded outside walls store it securely and prevents damage.

Material Heavy duty padded nylon
Measures 20 1/2" W x 12" H x 12" D
Features Padded shoulder strap
External pocket
Carrying grip



MCJB

IBO DRUMS IBO BAGS



Made from Mango Wood (Mangifera Sp.L.)

IBO DRUMS

The MEINL Ibo Drums perfectly combine tradition with modern innovation. "Ibo" is the Nigerian name for "pottery" where these unique drums originate. They all have a wide spectrum of sounds, are easy to play and offer many great features.

FIBERGLASS IBO DRUMS

The MEINL Fiberglass Ibo Drums have a wide variety of different sounds and the fiberglass body make them nearly unbreakable.

- Size** Large
- Material** Premium fiberglass
- Features** Built in microphone hole
Resistant shell construction
- Includes** Foam padded base
- Colours** BKO = Black Ornament
BKR = Black / Red
HC = Honeycomb

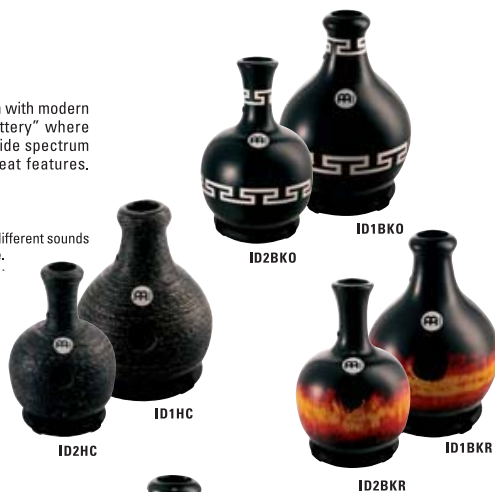

FIBERGLASS TRI SOUND IBO DRUM

The MEINL Tri Sound Ibo Drum features an additional rawhide playing surface and an extra thin bottom for enhanced sound.

- Size** Large
- Material** Premium fiberglass
- Features** Rawhide playing surface
Built in microphone hole
Resistant shell construction
- Includes** Foam padded base
- Colour** GO = Gold Ornament



Extra thin bottom for enhanced sound



FIBERGLASS TRI SOUND IBO DRUM

The MEINL Tri Sound Ibo Drum features an additional fiberglass playing surface and an extra thin bottom for enhanced sound.

- Size** Large
- Material** Premium fiberglass
- Features** Extra fiberglass playing surface
Built in microphone hole
Resistant shell construction
- Includes** Foam padded base
- Colour** BKO = Black Ornament



Extra thin bottom for enhanced sound



FIBERGLASS IBO DRUM, MINI

This MEINL Fiberglass Ibo Drum is smaller sized and offers a variety of effect sounds.

- Size** Mini
- Material** Premium fiberglass
- Features** Smaller sized
Built in microphone hole
Resistant shell construction
- Includes** Foam padded base
- Colour** BKO = Black Ornament



WOOD IBO DRUM

This unique instrument is another true MEINL innovation. It features a wooden body for a wide sonic range.

- Size** Large
- Material** Made from Mango Wood (Mangifera Sp.L.)
- Features** Dry tones
Built in microphone hole
Resistant shell construction
- Includes** Foam padded base



ID6

CERAMIC IBO DRUM

The ceramic body of this Ibo Drum causes a slight enhancement of the higher frequencies, with fat and powerful bass tones.

- Size** Large
- Material** Ceramic
- Features** Full and rich sounds
Built in microphone hole
- Includes** Foam padded base
- Colour** RB = Red/Brown



ID7RB

CERAMIC IBO DRUM

The special feature of this MEINL Ceramic Ibo Drum is the fiberglass bottom for extra sound options.

- Size** Large
- Material** Ceramic
- Features** Fiberglass playing surface
Built in microphone hole
- Includes** Foam padded base
- Colour** RB = Red/Brown



ID8RB



Extra fiberglass bottom for more sound options

PROFESSIONAL IBO BAGS

The MEINL Ibo Bag fits all common clay drum models and is the perfect solution for transporting these valuable and fragile instruments. Its heavy duty padded outside walls store it securely and prevents damage.

- Size** Small (9 3/4" W x 13 1/3" H x 9 3/4" D)
Medium (11" W x 14 1/2" H x 11" D)
- Material** Heavy duty padded nylon
- Includes** Padded shoulder strap
Carrying grip
External pocket



MIB-S

MIB-M



DARBUKAS AND DOUMBEKS

Darbukas and Doumbeks have their origin in Middle Eastern music. They are very popular in countries where music and rhythm are part of daily life. Later on they found their way into Western civilization and have become a very popular instrument in today's modern music. MEINL offers a wide range of premium darbukas and doumbeks with outstanding features and sound qualities.

ALUMINUM DARBUKAS, PLAIN

These Turkish style MEINL Darbukas feature fat lows and ringing highs with a wide range between.

- Sizes** 5 1/3" x 9 1/4"
5 7/8" x 11"
7 1/4" x 13 1/3"
8" x 14 1/2"
- Material** Aluminum
Features Synthetic heads
Includes Tuning key



ALUMINUM DARBUKAS, HAND HAMMERED

These MEINL Turkish style Darbukas have a beautifully hand hammered shell. They offer resonant lows and ringing highs with a wide range between.

- Sizes** 5 7/8" x 11"
7 1/4" x 13 1/3"
8" x 14 1/2"
- Material** Aluminum
Features Synthetic heads
Hand hammered shell
Includes Tuning key



ALUMINUM JINGLE DARBUKAS, HAND HAMMERED

These MEINL Aluminum Darbukas feature a beautifully hand hammered shell and built in jingles which adds a nice rattling effect and enhances their sound spectrum tremendously.

- Sizes** 5 7/8" x 11"
8" x 14 1/2"
- Material** Aluminum
Features Built in jingles
Synthetic heads
Hand hammered shell
Includes Tuning key



COPPER DARBUKAS, BRASS PLATED HAND HAMMERED

These unique instruments are made entirely of copper with a brass plated- and hand hammered shell. Strong high tones with resonant lows.

- Sizes** 7 1/2" x 14 3/4"
7 7/8" x 15 1/2"
- Material** Copper
Features Synthetic head
Hand hammered shell
Includes Carrying bag
Spare head
Tuning key



COPPER DARBUKAS, HAND ENGRAVED

The beautifully hand engraved shell of this copper darbuka is outstanding in sound and look!

- Sizes** 7 1/2" x 14 3/4"
7 7/8" x 15 1/2"
- Material** Copper
Features Natural rawhide
Hand engraved shells
Includes Carrying bag
Spare head
Tuning key



PROFESSIONAL DARBUKA BAG

The MEINL Darbuka Bag is made from heavy duty padded nylon with reinforced stitching and is equipped with a double-slide zipper, a padded shoulder strap, and a carrying grip. It protects your instruments and provides hassle free transportation.

- Material** Heavy duty padded nylon
Features Double-slide zipper
Additional upright zipper
Padded shoulder strap
Carrying grip
External pocket



Additional upright zipper

DOUMBEKS, DOUMBEK BAG



ALUMINUM DOUMBEKS

Hand made entirely of aluminum, the MEINL Doumbek is outstanding in sound and quality reaching from resonant lows to ringing highs. Available as black vinyl covered or copper finished versions.

- Size** 8 1/2" x 17 1/8"
- Material** Aluminum
- Features** Synthetic heads
- Includes** Carrying bag
Spare head
Tuning key



HE-3000

HE-3020

ALUMINUM DOUMBEK, SMALL

The shell of this MEINL Doumbek is made entirely from aluminum and covered with black vinyl. Due to its smaller size, it has a very soft tone yet still retains volume and richness.

- Size** 5 7/8" x 11"
- Material** Aluminum
- Features** Synthetic head
- Includes** Carrying bag
Spare head
Tuning key



HE-3205

NEW

ALUMINUM DOUMBEK, HAND HAMMERED

The aluminum shell of this MEINL Doumbek is completely hand hammered for a most appealing look.

- Size** 8 1/2" x 17 1/8"
- Material** Aluminum
- Features** Synthetic head
Hand hammered shell
- Includes** Carrying bag
Spare head
Tuning key



HE-3030

COPPER DOUMBEK, HAND ENGRAVED

The copper shell of this MEINL Doumbek is hand engraved for a stunning look. A very traditionally looking and sounding instrument.

- Size** 8 1/2" x 17 1/8"
- Material** Copper
- Features** Synthetic head
Hand engraved shell
- Includes** Carrying bag
Spare head
Tuning key



HE-3012

ALUMINUM DOUMBEK, WOOD COVERED

The shell of this MEINL Doumbek is made from aluminum and is completely covered with a layer of the finest wood. Combined with its synthetic head, it ensures a warm and smooth tone with lots of low end and less ringing highs.

- Size** 8 1/2" x 17 1/8"
- Material** Aluminum
- Features** Wood covered shell
Synthetic head
- Includes** Carrying bag
Spare head
Tuning key



HE-3400

NEW

COPPER DOUMBEK, HAND HAMMERED

The shell of this MEINL Doumbek is made entirely from hand hammered copper, giving it a stunning and wonderful look. This is truly a visually modern instrument with a traditional sound.

- Size** 8 1/2" x 17 1/8"
- Material** Copper
- Features** Synthetic head
Hand hammered shell
- Includes** Carrying bag
Spare head
Tuning key



HE-3015

NEW

PROFESSIONAL DOUMBEK BAG

The MEINL Doumbek Bag is made from heavy duty padded nylon with reinforced stitching and is equipped with a double-slide zipper, a padded shoulder strap, and a carrying grip. It protects your instruments and provides hassle free transportation.

- Material** Heavy duty padded nylon
- Features** Double-slide zipper
Additional upright zipper
Padded shoulder strap
Carrying grip
External pocket



Additional upright zipper



MDOB

NEW



RITUAL DRUMS

MEINL combines traditional instruments with modern technology and innovations. The range of Ritual Drums is a line of innovative instruments which originate in many different cultures from all around the world. MEINL's expertise in R&D helped in creating these authentic and high quality range of instruments which is outstanding in the percussion world.

WAH WAH TUBES

The MEINL Wah Wah Tube is a tubular effect instrument that delivers smooth, bell-like tones with an incredible sustain. By covering and uncovering the sound hole a "wah wah" effect can be achieved. An amazing effect instrument with surprising results and a lot of fun to play.

- Sizes** Small (high pitch)
Large (low pitch)
- Material** Aluminum
- Includes** Rubber mallet
- Colour** BK = Black



TALKING DRUM

The Talking Drum has its origin in West Africa. The traditional technique involves squeezing the tuning ropes while striking the head with a small bent wooden mallet. This causes the pitch of this extraordinary drum to vary widely and produces a unique effect.

- Size** 7 1/2"
- Material** Premium fiberglass
- Features** Durable synthetic heads
Wooden rims
Nylon tuning strap
- Includes** Curved wooden beater
- Colour** BK = Black



BATAS

Having originated in West Africa and rooted in religious ceremonies, the Bata Drum made its way to Western civilization over 300 years ago. The largest Bata is called Iya and functions together with the medium Bata called Itotele. The performance usually includes a dual between the players where they question, fight, and answer each other in rhythmic patterns. The smallest bata drum is the Okonkolo and its task is to perform frequent rhythmic patterns during rituals. The MEINL Batas are made from premium fiberglass for more durability, lighter weight and comfortable playing.

- Sizes** Okonkolo 5 1/4" & 8"
Itotele 5 3/4" & 8 3/4"
Iya 6 3/4" & 12"
- Material** Premium fiberglass
- Features** Hand selected buffalo heads
Traditional TTR-Rim
- Includes** Nylon strap
Tuning key
- Colour** BK = Black



TAMBORA

The rhythm of the Merengue has its roots in the Dominican Republic where the use of a Tambora drum is essential in creating this style of music. It is traditionally played with the drum sitting on the lap, and struck with a beater on one side, and the bare hand on the other side of the drum.

- Size** 11"
- Material** Rubber Wood (*Hevea brasiliensis* Muell.-Arg.)
- Features** True Skin Buffalo Heads
Black powder coated hardware
- Includes** Nylon strap
Wooden beater
Tuning key
- Colour** AB-M = African Brown
- Finish** Matt



MTA1AB-M

BERIMBAU

The MEINL Berimbau is another traditional African instrument which is very prevalent in Brazil and other countries of South America. Three parts are involved: The metal plate, the small caxixi, and the stick. When played correctly, it produces a very exotic and singing sound which is great for World Music and other modern productions.

- Material** Premium fiberglass
- Includes** Small Caxixi
Metal plate
Wooden Stick
Carrying bag
- Colour** R = Red



BE1R

RAINMAKER

The MEINL Rainmaker is uniquely different. Due to the circular construction, it can be mounted on a cymbal stand and by simply turning the instrument a drizzle can immediately change into the sound of a monsoon. The major advantage over other rainmakers is that the sound can be continuous without changes in intensity.

- Material** Premium fiberglass
- Features** Circular construction
- Includes** Ergonomically shaped handle
- Colours** BK = Black
R = Red



RA7R

RA7BK

CANDELA® PERCUSSION CYMBALS

The MEINL Candela® Series of Percussion Cymbals have been designed to meet the specific requirements of today's percussionists. They are extremely thin cymbals which produce soft, exotic tones, are tonally matched and respond even at lower volumes.



CA10S

PERCUSSION SPLASH

The percussion splash is an extremely thin, quick sounding cymbal – perfect for fast percussive accents.

- Size** 10"
- Material** B20 Bronze
- Features** Hand hammered
Brilliant finish
Fast response and attack
Quick decay

PERCUSSION CRASHES

The crashes are thin, tonally matched cymbals which can be played by hand or hit with a stick. They respond fast and decay quickly.

- Sizes** 14"
16"
- Material** B20 Bronze
- Features** Hand hammered
Brilliant finish
Fast response and attack
Quick decay

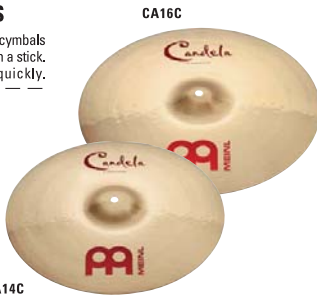

CA14C

CA16C

TIMBALE CRASH/RIDE

It's the perfect cymbal for timbale playing. It has a loud, penetrating bell and a full, warm crash sound.

- Size** 18"
- Material** B20 Bronze
- Features** Hand hammered
Brilliant finish
Cutting bell sound
Great crash sound



CA18CR

PERCUSSION JINGLE BELL

A great cymbal with an exotic sound. Six pairs of jingles attached to this cymbal produce a rattling effect.

- Size** 14"
- Material** B8 Bronze
- Features** Precisely hammered
Built in jingles



CA14PJB

TAM TAM STAND

The MEINL Tam Tam Stand holds all common tam tams up to 22" diameter.

- Material** Black powder coated steel
- Features** Holds tam tams up to 22" diameter

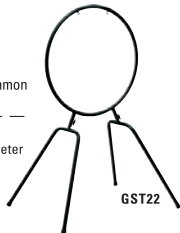

GST22

TAM TAMS

The MEINL Percussion Tam Tams create a voluminous dark sound with an extremely long sustain.

- Sizes** 20"
22"
- Material** B20 Bronze
- Features** Hand hammered
Long sustain



G22

G20

CYMBAL TROLLEY

The MEINL Cymbal Trolley holds cymbals up to 22" in diameter and has an external compartment for cymbals up to 14" in diameter. The whole bag is mounted on two stable wheels and has a length adjustable grip that allows convenient transportation of those heavy instruments.

- Size** 22"
- Material** Bag: Heavy duty padded nylon
Wheels: Hard plastic
- Features** External cymbal compartment
External accessory compartment
Internal padded cymbal dividers
Stable wheels
Length adjustable grip



Length adjustable grip

CYMBAL BAG

The MEINL Cymbal Bag holds cymbals up to 22" diameter. An external compartment which holds cymbals up to 14" allows a comfortable weight balance when packed.

- Size** 22"
- Material** Heavy duty padded nylon
- Features** External compartment
Padded dividing pads
Padded shoulder strap
Carrying grip

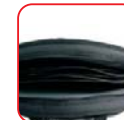

MCB22

STICK BAG

The MEINL Stick Bag offers four spacious sections for drumsticks and a separate compartment for drum keys, small tools and other valuables.

- Material** Heavy duty padded nylon
- Features** External pocket
Shoulder strap
Extension straps



MSB-1

Spacious stick compartments for quick access

CYMBAL STACKERS

The MEINL Cymbal Stackers enable a space saving set up of various cymbals on top of each other.

- Sizes** ø 6 mm
ø 8 mm
- Material** Chrome plated steel
- Features** Felt washers



MC-CYS

MC-CYS8

CANDELA® CYMBALS / BAGS



Stable wheels



MCB22-TR



DRUMSTICK HOLDER

The MEINL Drumstick Holder firmly attaches to any common stand and stores a number of drumsticks, mallets, brushes and other accessories in its roomy pouch for ready access when needed.

- Material** Chrome plated steel
Black textile pouch
- Features** Strong mounting clamp



MC-DSH

CYMBAL HOLDER

This MEINL holder comfortably places any cymbal within a drum or percussion set up.

- Material** Chrome plated steel
- Features** Knurled surface
Felt washers



MC-CY

SPARE PARTS



CONGAS

SERIES	SIZE	HEAD	RIM	LUG	BRACKET
HEADLINER	10"	HHEAD10	HRIM10	HCLUG	HCBRACKET-02
HEADLINER	11"	HHEAD11	HRIM11	HCLUG	HCBRACKET-02
HEADLINER	12"	HHEAD12C	HRIM12C	HCLUG	HCBRACKET-02
MCC11	11"	TS-B-38	SSR-25	LUG-03	BRACKET-15
MCC1134	11 3/4"	TS-B-39	SSR-26	LUG-03	BRACKET-15
MCC1212	12 1/2"	TS-B-40	SSR-27	LUG-03	BRACKET-15
LC11	11"	TS-B-52	TTR-28	LUG-03	BRACKET-20
LC1134	11 3/4"	TS-B-53	TTR-29	LUG-03	BRACKET-20
LC1212	12 1/2"	TS-B-54	TTR-30	LUG-03	BRACKET-20
MEC11	11"	TS-B-28	SSR-09	LUG-03	BRACKET-14
MEC1134	11 3/4"	TS-B-29	SSR-11	LUG-03	BRACKET-14
MEC1212	12 1/2"	TS-B-30	SSR-14	LUG-03	BRACKET-14
FC11	11"	TS-B-34	SSR-22	LUG-01	BRACKET-14
FC1134	11 3/4"	TS-B-35	SSR-23	LUG-01	BRACKET-14
FC1212	12 1/2"	TS-B-36	SSR-24	LUG-01	BRACKET-14
FL10	10"	TS-B-01	SSR-06	LUG-01	
FL11	11"	TS-B-03	SSR-07	LUG-01	
FL12	12"	TS-B-15	SSR-12	LUG-01	
FL13	13"	TS-B-21	SSR-15	LUG-01	
MP11	11"	TS-B-34	SSR-22	LUG-01	BRACKET-14
MP1134	11 3/4"	TS-B-35	SSR-23	LUG-01	BRACKET-14
MP1212	12 1/2"	TS-B-36	SSR-24	LUG-01	BRACKET-14
MSA11AWA	11"	TS-B-07	SSR-08	LUG-02	BRACKET-16
MSA1134AWA	11 3/4"	TS-B-11	SSR-10	LUG-02	BRACKET-16
MSA1212AWA	12 1/2"	TS-B-17	SSR-13	LUG-02	BRACKET-16
MSA11ZFAM	11"	TS-B-07	SSR-37	LUG-01	BRACKET-14
MSA1134ZFAM	11 3/4"	TS-B-11	SSR-38	LUG-01	BRACKET-14
MSA1212ZFAM	12 1/2"	TS-B-17	SSR-39	LUG-01	BRACKET-14
WC11	11"	TS-B-44	TTR-23	LUG-01	BRACKET-14
WC1134	11 3/4"	TS-B-45	TTR-24	LUG-01	BRACKET-14
WC1212	12 1/2"	TS-B-46	TTR-25	LUG-01	BRACKET-14



TIMBALES

SERIES	SIZE	HEAD	RIM	LUG	BRACKET
HT1314	13" 14"	HEAD-24 HEAD-22	RIM-37 RIM-38	LUG-26 LUG-26	BRACKET-18 BRACKET-18
MT1415	14" 15"	HEAD-22 HEAD-23	RIM-23 RIM-24	LUG-17 LUG-17	BRACKET-12 BRACKET-12
TT1BK	13" 14"	HEAD-24 HEAD-22	RIM-21 RIM-22	LUG-17 LUG-17	
AV1BK	14" 15"	HEAD-22 HEAD-23	RIM-27 RIM-28	LUG-17 LUG-17	
LC1	14" 15"	HEAD-22 HEAD-23	RIM-19 RIM-20	LUG-16 LUG-16	BRACKET-08 brass BRACKET-09 brass, small BRACKET-10 chrome BRACKET-11 chrome, small
BT1415	14" 15"	HEAD-22 HEAD-23	RIM-19 RIM-20	LUG-16 LUG-16	BRACKET-10 chrome BRACKET-11 chrome, small
MDT13CH	13"	HEAD-43	RIM-31	LUG-21	BRACKET-13
MIT810CH	8" 10"	HEAD-41 HEAD-42	RIM-29 RIM-30	LUG-21 LUG-21	BRACKET-13 BRACKET-13



BONGOS

SERIES	SIZE	HEAD	RIM	LUG
HB100	6 3/4" 8"	HHEAD634W HHEAD8W	HRIM634W HRIM8W	HBLUG HBLUG
FWB100	3 1/2" 4 1/4"	TS-B-31 TS-B-32	SSR-16 SSR-17	LUG-19 LUG-19
FWB190	6 3/4" 8"	HEAD-38 HEAD-39	SSR-18 SSR-19	LUG-22 LUG-22
FWB200	6 3/4" 8"	HEAD-38 HEAD-39	SSR-20 SSR-21	LUG-22 LUG-22
FFB200	6 3/4" 8"	TS-B-50 TS-B-51	SSR-34 SSR-35	LUG-23 LUG-23
FWB300	6 3/4" 8"	TS-C-13 TS-C-14	TTR-31 TTR-32	LUG-22 LUG-22
FWB400	7" 8 1/2"	TS-C-02 TS-C-03	SSR-02 SSR-04	LUG-07 LUG-07
FFB400	7" 8 1/2"	TS-C-02 TS-C-03	SSR-02 SSR-04	LUG-07 LUG-07
WB500	7" 9"	TS-C-11 TS-C-12	TTR-26 TTR-27	LUG-07 LUG-07
CS400	7" 8 1/2"	TS-C-02 TS-C-03	SSR-02 SSR-04	LUG-07 LUG-07



DJEMBES

SERIES	SIZE	HEAD	RIM	LUG	BRACKET
HDJ600	12"	HHEAD12W	HRIM12W	HDLUGW	HDBRACKET-02
DJW3	12"	TS-G-01	SSR-29	LUG-04	
DJF3	12"	TS-G-01	SSR-29	LUG-05	
DJW2	12 3/4"	TS-G-02	SSR-30	LUG-04	
DJW21	21"	TS-C-09	TTR-22	LUG-06	
DJWR3	12"	TS-CA-01			



DANCING DRUMS

SERIES	SIZE	HEAD	RIM	LUG	BRACKET
HC301	8 1/2"	HHEAD8,5	HRIM8,5	HDCLUG	HDBRACKET-02
HDJ400	12"	HHEAD12	HRIM12	HDLUG	HDBRACKET-02
HDJ200	8"	HHEADJ8	HRIMDJ8	HD200LUG	
HFDD1	8 3/4"	HHEADHFDD1	HRIMHFDD1	HFDDLUG	HFDDBRACKET
HFDD2	8"	HHEADHFDD2	HRIMHFDD2	HFDDLUG	HFDDBRACKET
HFDD3	7 1/2"	HHEADHFDD3	HRIMHFDD3	HFDDLUG	HFDDBRACKET



DARBUKAS/DOUMBEKS

SERIES	SIZE	HEAD	FOR MODEL NO.
Plastic Heads	5 1/3"	HE-HEAD-100	HE-100
	5 3/4"	HE-HEAD-3205	HE-3205
	5 7/8"	HE-HEAD-101	HE-101 / HE-111 / HE-311
	7 1/4"	HE-HEAD-103	HE-103 / HE-113
	7 1/2"	HE-HEAD-214	HE-214
	7 7/8"	HE-HEAD-215	HE-215
	8"	HE-HEAD-104	HE-104 / HE-114 / HE-314
	8 1/2"	HE-HEAD-3000	HE-3000 / HE-3012 / HE-3020 / HE-3030 HE-3015 / HE-3400
Natural Heads	7 1/2"	HE-HEAD-204	HE-204
	7 7/8"	HE-HEAD-205	HE-205



RITUAL DRUMS

SERIES	SIZE	HEAD	RIM	LUG	BRACKET
BA1	5 1/4"	HEAD-07	RIM-04	LUG-12	
		HEAD-08	RIM-05	LUG-12	
BA2	5 3/4"	HEAD-09	RIM-06	LUG-12	
		HEAD-10	RIM-07	LUG-12	
BA3	6 3/4"	HEAD-11	RIM-08	LUG-12	
		HEAD-12	RIM-09	LUG-12	
HCG89	8"	HEAD-05	TTR-05	LUG-11	HDBRACKET-02
		HEAD-06	TTR-08	LUG-11	HDBRACKET-02
MTA1	11"	TS-B-09 (NT)	RIM-03	LUG-10	BRACKET-06
		TS-B-10 (WH)	LUG-10	LUG-10	BRACKET-06
TD7	7 1/2"	HEAD-35	RIM-25		

SAMBA SERIES

SERIES	SIZE	HEAD	RIM	LUG	BRACKET
PA10	10"	HEAD-44	RIM-33	LUG-24	BRACKET-19
PA12	12"	HEAD-45	RIM-34	LUG-24	BRACKET-19
QW7	8"	HEAD-13	RIM-10	LUG-13	
RE10	10"	HEAD-48	RIM-39	LUG-29	
RE12	12"	HEAD-47	RIM-36	LUG-28	
RE12AB	12"	HEAD-47	RIM-36	LUG-32	
SU18	18"	HEAD-49	RIM-40	LUG-30	
SU20	20"	HEAD-46	RIM-35	LUG-27	
SU22	22"	HEAD-50	RIM-41	LUG-31	
TBR06	6"	HEAD-40	RIM-32	LUG-20	

STANDS / SPARE PARTS FOR STANDS

Timbale Stand, chrome	TMT
Double Stand for HC888/HC812	HDSTAND
10" Basket Stand for HC555	HSTAND10
11" Basket Stand for HC555/HC512	HSTAND11
12" Basket Stand for HC512	HSTAND12
Cowbell Holder, complete for Meinl Timbales	STAND-01
Cowbell Holder, complete for HT1314 Timbales	HDSTAND-01
L-Shaped Clamp for top part for TMB	STAND-18
Fast Lock Set, chrome	STAND-14
Fast Lock Set, black	STAND-15
Memory Clamp, chrome, for upper stand tube	STAND-11
Memory Clamp, chrome, for middle stand tube	STAND-07
Memory Clamp, black, for middle stand tube	STAND-08
Memory Clamp, chrome, for lower stand tube	STAND-09
Memory Clamp, black, for lower stand tube	STAND-10
Rubber Feet (set of 3pcs) for Timbales, Bongo, Djembe Stand	STAND-16
Rubber Feet (set of 3pcs) for Steely-II Stands	STAND-35
Rubber Tops (set of 3pcs.) for Steely Stands	STAND-21
Screw Set complete for Steely Stand, black	STAND-22
Screw Set complete for Steely Stand, chrome	STAND-23
Screw Set complete for Steely Stand, gold tone	STAND-24
Socket Screw (set of 2pcs.) black	STAND-26
Socket Screw (set of 2pcs.) chrome	STAND-27
Socket Screw (set of 2pcs.) gold tone	STAND-28
Upper Stand Section, complete from TMB	STAND-34

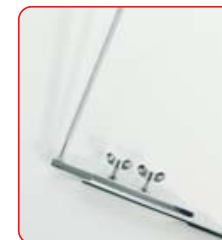

OTHER PARTS

Lug Oil	SPARE-09
Tambora Beater	SPARE-01
Talking Drum Beater	SPARE-10
Chimes Beater	NIN0567
Wah Wah Beater	SPARE-12
Guiro Scraper Wood (GU1)	SPARE-04
Guiro Scraper Plastic (GU2 / GU6 / GU7)	SPARE-13
Cowbell Bolt, complete	SPARE-11
Chimes Holder	SPARE-07
Conga Saver for 8mm Lugs (set of 6pcs.)	CONGA-SAVER8
Conga Saver for 10mm Lugs (set of 6pcs.)	CONGA-SAVER10
Tuning Key, 13mm + 14mm, L shaped, gold tone	KEY-01
Tuning Key, 13mm + 14mm, L shaped, chrome	KEY-02
Tuning Key, 14mm, chrome	KEY-03
Tuning Key, 13mm, chrome	KEY-04
Tuning Key, 12mm + 13mm	KEY-05
Tuning Key, 10mm	KEY-06
Standard Drum Key	KEY-07
Tuning Key for Pandeiro	KEY-08





FIRST MOVE

NINO® PERCUSSION

FIRST MOVE

The new generation of musical instruments for early childhood education.

NINO® instruments meet exactly the requirements of early childhood education and are perfectly suitable for the use in kindergartens, schools, music therapy and for musical activities at home.

The easy handling and an appealing design are standard for all NINO® instruments. They are noteworthy due to their professional features, the great sound and their outstanding quality. The strong, childproof workmanship guarantees years of trouble-free use of all NINO® instruments.

FIRST MOVE



THE DIFFERENCE

THE SAFETY

NINO® instruments have been tested by the Landesgewerbeanstalt Bayern, Germany (LGA), Institute for the Testing of Goods and Quality Monitoring and have been awarded with the LGA Test Certificate. This means that NINO® instruments comply with the strict requirements of the European Community Directives 88/378EC and 87/357/EC.

PRODUCT TESTING

All NINO® instruments are regularly tested for safety and sanitary harmlessness according to the EC Directives 88/378/EC (Toy Safety Directive) and 87/357/EC (Imitation of Food).

The tests are carried out by the Landesgewerbeanstalt Bayern, Germany (LGA), a modern testing and consulting services organization with over 30 branches worldwide.

As a recognized institute for the testing of goods and quality monitoring, the LGA is entitled to award the GS and LGA test marks which are accepted throughout Europe and internationally as a guarantee of safety.

NINO® INSTRUMENTS PASS THE FOLLOWING TESTS:

Testing in dependence on the Toy Safety Directive (88/378/EC)

Mechanical and physical characteristics

Inflammability

Migration of certain parts

Saliva and perspiration resistance

Colorfastness

Determination of the content of Pentachlorophenol (PCP)

Testing with regard to pesticides

Valuation in accordance with EC Directive 87/357/EC

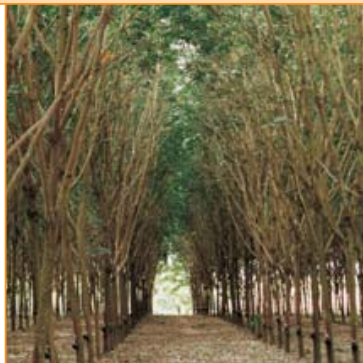

Rubber Wood plantation farm in Thailand

CERTIFICATION

After passing all tests, the internationally accepted LGA Test Certificate was awarded for all NINO® percussion instruments. This certificate vouches for quality and safety.

MATERIAL & ECOLOGY

Wood is a raw material which is present in almost every part of our daily life. Trees are an important part of the complex eco-system while healthy forests are imperative for the Earth's atmosphere.

Only Rubber Wood (*Hevea brasiliensis* Muell.-Arg.) is used for the making of NINO® percussion instruments. This wood fulfills the CITES regulations ('Convention on International Trade in Endangered Species of Wild Fauna and Flora') and originates from environmentally controlled forests from industrial wood plantations.

WOOD FROM ENVIRONMENTALLY CONTROLLED WOOD PLANTATIONS

Thailand is a logical manufacturing base for percussion instruments due to the fact that the Hevea Brasiliensis, which was indigenous to Brazil and later transported by way of England to Asia, has been commercially grown in Southeast Asia during the last century on plantation farms for the production of Latex.

The traditional plantation of Rubber Wood (*Hevea brasiliensis* Muell.-Arg.) meets all ecological requirements. In a natural evolution, new trees are planted and the older ones, which have ceased to provide latex, are harvested. In this way, plenty of raw material is available and the valuable rain forest eco-system is preserved.

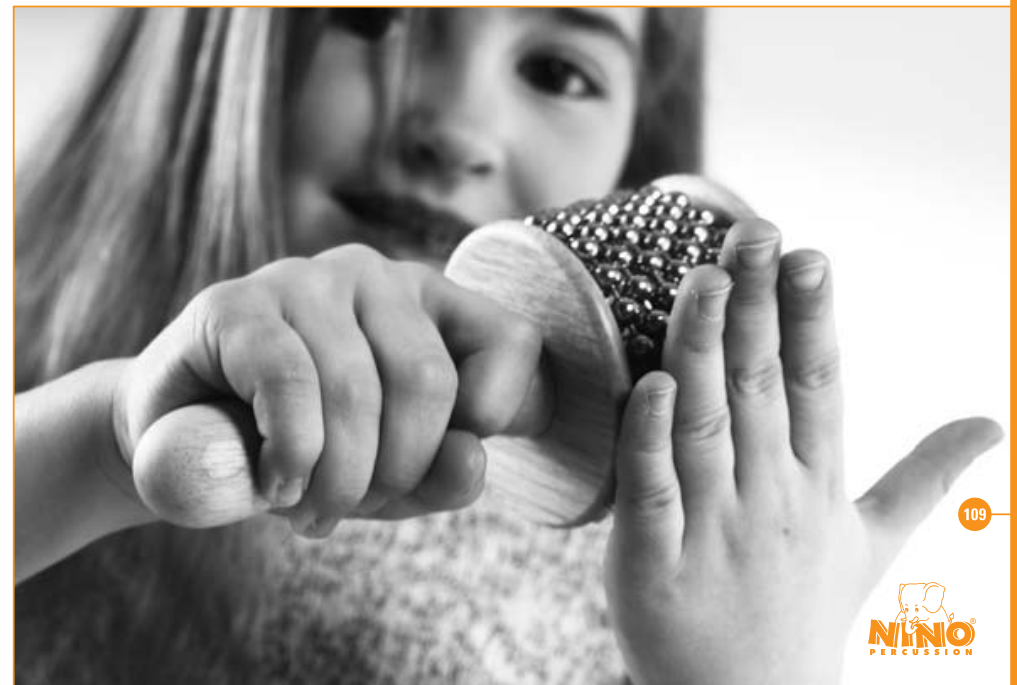

FEEL THE MAGIC OF THE DRUMS

CONGA SETS



CONGA SETS

NINO® Congas are famous for their professional workmanship. Available are fiberglass or wood sets. They all include basket stands and can therefore be played individually or in a set configuration.

NINO910 WOOD CONGA SETS

The NINO910 Wood Congas are ideal for first time players or schools. Height adjustable stands included.

- Size** 9" & 10"
28" tall
- Material** Rubber Wood (*Hevea brasiliensis* Muell.-Arg.)
- Features** Hand selected buffalo heads
Rounded rims for playing comfort
Black powder coated hardware
- Includes** Height adjustable basket stands with quick set up system
Tuning key
- Colours** NT = Natural
WR = Wine Red



NINO® Wood Congas are equipped with strong tuning bracket

The rounded rim offers perfect playing comfort without harming the wrist or palm

NINO89 WOOD CONGA SETS

The NINO89 Wood Congas can be played standing up or sitting down and are therefore the perfect congas for children in kindergartens.

- Size** 8" & 9"
22" tall
- Material** Rubber Wood (*Hevea brasiliensis* Muell.-Arg.)
- Features** Hand selected buffalo heads
Rounded rims for playing comfort
Black powder coated hardware
- Includes** Basket stands
Tuning key
- Colours** NT = Natural
WR = Wine Red



FIBERGLASS CONGA SETS

Our fiberglass is a high quality material, manufactured by hand, into especially powerful sounding shells. The advantage over wood congas is the lower weight which makes handling much easier. The model with its colourful Harlekin® design will certainly attract attention.

- Size** 8" & 9"
22" tall
- Material** Premium fiberglass
- Features** Hand selected buffalo heads
Rounded rims for playing comfort
Black powder coated hardware
- Includes** Basket stands
Tuning key
- Colours** HK = Harlekin
R = Red



WOOD DJEMBES



The Djembe is the most popular African drum. Even untrained players are quickly able to draw different tones from this great instrument. The NINO® Wood Djembe has a diameter of 10" and a height of 21" and is the perfect drum for children in kindergarden or elementary school.

- Size** 10"
21" tall
- Material** Rubber Wood (*Hevea brasiliensis* Muell.-Arg.)
- Features** Hand selected goat heads
Rounded rims for playing comfort
Black powder coated hardware
Patented Floatune® Tuning System
- Includes** Tuning key
- Colours** NT = Natural
WR = Wine Red



The rounded rim offers perfect playing comfort without harming the wrist or palm

NINO® Djembes are equipped with the patented Floatune® Tuning System which avoids drilling into the shell



NINO23NT

NINO23WR

WOOD BONGOS

The NINO® Wood Bongo is an affordable yet high quality instrument with great versatility in sound. Children love the coloured Harlekin® design!

- Size** 6 1/2" & 7 1/2"
- Material** Rubber Wood (*Hevea brasiliensis* Muell.-Arg.)
- Features** Hand selected buffalo heads
Rounded rims for playing comfort
- Includes** Tuning key
- Colours** NT-HK = Natural Shell / Harlekin Hardware
NT-BK = Natural Shell / Black Hardware
WR-BK = Wine Red Shell / Black Hardware



NINO3NT-BK

NINO3WR-BK

NINO3NT-HK

DJEMBES, BONGOS



ABS BONGOS PLUS

A real alternative! The NINO® ABS Bongo Plus is an affordable bongo with a great sound and functional hardware. Shells made of ABS plastic make this bongo lighter than comparable wood models.

- Size** 6 1/2" & 7 1/2"
- Material** ABS Plastic
- Features** Hand selected buffalo heads
Rounded rims for playing comfort
Black powder coated hardware
- Includes** Tuning key
- Colours** BK-BK = Black Shell / Black Hardware
R-BK = Red Shell / Black Hardware



NINO17BK-BK

NINO17R-BK



The tuning system is outstanding in this price range

BONGO BAG

The NINO® Bongo Bag featuring the Harlekin® design can be used for transporting a bongo or other small percussion items.

- Material** Nylon
- Includes** Padded shoulder strap
Carrying grip



NINO801

BONGO STAND



The patented NINO® Bongo Stand has been developed especially for kids and their height in order to offer them a safe and comfortable playing position. It can be tilted in a 90° angle and height adjusted from 31" up to 45" so children can play standing up or sitting down. The NINO® Bongo Stand is also suitable for many other common bongo models.

- Material** Chrome plated steel
- Features** Fully height adjustable from 31" to 45"
90° angle adjustable
Tripod stand with rubber feet
Suitable for other common bongo models



The latch of the patented NINO® Bongo Stand holds the bongo absolutely stable

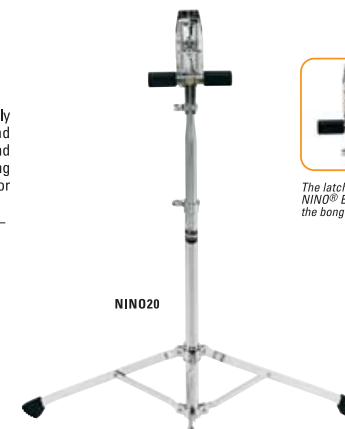

NIN020



EXPERIENCE SOUND WITH FUN AND PLEASURE

ABS DRUMS

The colourful NINO® ABS Drums are not only durable, they also have a powerful sound. Shells made from ABS Plastic and synthetic heads guarantee great stability and a long life. With their low weight of about two pounds and their outstanding workmanship, NINO® ABS Drums are also perfectly suitable for toddlers.



ABS CONGAS

Size 6"
Material ABS Plastic
Features Synthetic head
Includes Nylon strap
Colours G/Y = Green / Yellow
 R/BK = Red / Black
 R = Red



ABS DJEMBS

Size 8"
Material ABS Plastic
Features Synthetic head
Includes Nylon strap
Colours G/Y = Green / Yellow
 R/BK = Red / Black
 R = Red



ABS BONGOS

Size 6 1/2" & 7 1/2"
Material ABS Plastic
Features Synthetic head
Includes Nylon strap
Colours BK = Black
 G/Y = Green / Yellow
 R = Red



ABS DRUMS



ABS HAND DRUMS

The multi-coloured NINO® ABS Hand Drums offer more than just tonal variety. The unbreakable shells and durable synthetic heads ensure years of trouble-free use.



Because of the patented tuning system, the drums come pretuned and ready to play right out of the box

Sizes 6"
 10"
 12"
Material ABS Plastic
Features Synthetic head
Includes Wooden beater
Colours B = Blue
 BK = Black
 GR = Green
 R = Red
 Y = Yellow



ABS JINGLE DRUMS

The NINO® Jingle Drums offer enhanced sound options due to attached jingle pairs.



Size 10"
Material ABS Plastic with nickelsilver jingles
Features Synthetic head
Includes Wooden beater
Colours BK = Black
 R = Red



NEW AND AUTHENTIC SOUNDS

FRAME DRUMS

These NINO® Frame Drums are traditionally equipped with buffalo skin heads and come with a wooden beater. With their warm tone they can be used in various musical occasions.

- Sizes** 12 1/2"
15"
Material Buffalo skin heads
Features Velcro strap
Includes Wooden beater



WOOD TONE BLOCKS

The NINO® Wood Tone Blocks come with two tonally matched resonating bodies and are available in different sizes.

- Sizes** Small
Medium
Material Rubber Wood (*Hevea brasiliensis* Muell.-Arg.)
Features Tonally matched resonating bodies
Includes Wooden beater



WOOD A-GO-GO'S

The NINO® Wood A-go-go's are played with a wooden beater and produce a powerful sound. They can also be scratched like a guiro. These two playing styles leave room for creativity.

- Sizes** 1 row
2 rows
3 rows
Material Rubber Wood (*Hevea brasiliensis* Muell.-Arg.)
Features Different playing options
Includes Wooden beater



WOOD BLOCKS

The Wood Block is probably one of the oldest rhythm instruments and should be part of any percussion group. The NINO® Wood Blocks have an impressive sound and are available in two sizes.

- Sizes** Medium
Large
Material Rubber Wood (*Hevea brasiliensis* Muell.-Arg.)
Includes Wooden beater



ORIENTAL WOOD TONE BLOCKS

The NINO® Oriental Wood Tone Blocks come in two different versions: One model is played by holding it in the player's hand, which produces a slightly dampened sound. The model with the handle has a more high pitched and open sound.

- Material** Rubber Wood (*Hevea brasiliensis* Muell.-Arg.)
Includes Wooden beater



WOOD STIRRING DRUM

The eight wooden tongues produce different pitches when they are struck separately, like playing a xylophone. By stirring in the drum with the included beater a scale can be played. The combination of a stirring drum with a handle is an original MEINL Innovation.

- Material** Rubber Wood (*Hevea brasiliensis* Muell.-Arg.)
Features Ergonomically shaped handle
Includes Wooden beater



WOOD BALL STIRRING DRUMS

The NINO® Wood Ball Stirring Drums are a further development of the familiar stirring drum. The instrument is based on a clever design. When playing the drum, a wooden ball fastened to a nylon string strikes the tonally matched wooden tongues and produces a harmonic sound.

- Sizes** Small
Large
Material Rubber Wood (*Hevea brasiliensis* Muell.-Arg.)
Features Ergonomically shaped handle



SHAKING, FEELING, LISTENING

WOOD FROGS

The NINO® Wood Frogs have gained an enormous popularity over the last few years. Children especially love the authentic "ribbit" sound which is created by scratching the wooden beater on the frog's back. Great fun for kids and adults.

Sizes Small
Medium
Large
X-large
Material Wood
Features Creates original "ribbit" sound
Includes Wooden scratcher
Colour GR = Green

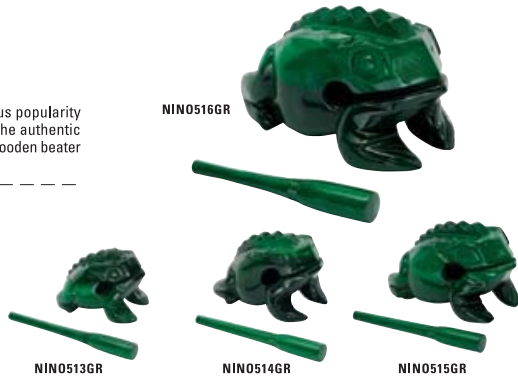

WOOD ANIMALS, MINI

The NINO® Wood Animals are great sounding miniature imitations of a grasshopper, snail, frog, and turtle. Scratching the wooden beater on the surface of the instruments creates a nice guiro-like sound. Great fun for kids and adults.

Size Mini
Material Wood
Features Creates guiro-like sounds



WOOD SHAKERS

Toddlers especially love these little rhythm instruments. NINO® Natural Wood Shakers have different fillings. A cylindrical shaped shaker is available in two different sizes, as well as a square, and a triangular shaped shaker assortment.

Shapes Cylindrical, small
Cylindrical, large
Square, 3 pcs set
Triangular, 3 pcs set
Material Rubber Wood (*Hevea brasiliensis* Muell.-Arg.)
Features Different sounding fillings



WOOD EGG SHAKERS

NINO® Wood Egg Shakers are very handy because of their shape. They also have a great sound with various pitches depending on their size.

Sizes Small
Medium
Large
Material Rubber Wood (*Hevea brasiliensis* Muell.-Arg.)



WOOD CLAVES

Claves are an essential instrument in Latin music and shouldn't be missing from any percussion set up. The NINO® Wood Claves are available as regular sized models. A second pair was especially designed to fit a child's hand size.

Sizes Small
Regular
Material Rubber Wood (*Hevea brasiliensis* Muell.-Arg.)
Features Sold as pairs



WOOD EGG MARACAS

Maracas are used for any style of music and are one of the most popular rhythm instruments worldwide. The NINO® Wood Egg Maracas have a nice warm sound and come with an ergonomically shaped handle.

Sizes Small
Medium
Material Rubber Wood (*Hevea brasiliensis* Muell.-Arg.)
Features Ergonomically shaped handle
Sold as pairs



WOOD MARACAS

The NINO® Wood Maracas sound very focused and have more attack.

Sizes Small
Medium
Material Rubber Wood (*Hevea brasiliensis* Muell.-Arg.)
Features Ergonomically shaped handle
Sold as pairs



SKIN MARACAS

NINO® Skin Maracas are entirely hand made and have a warm and mellow sound.

Sizes Small
Medium
Material Natural skin
Features Mellow sound
Ergonomically shaped wood handle
Sold as pairs



SKIN EGG SHAKER

The NINO® Skin Egg Shaker is entirely hand made and has a warm and mellow sound.

Material Natural skin



HAND PERCUSSION



SIMPLY CATCHY SOUNDS

DOUBLE SHAKER

The NINO® Double Shaker produces a clear and cutting sound with enhanced volume.

Material Rattan with natural skin hide bottom

CAXIXI

The NINO® Caxixi produces a clear and cutting sound.

Material Rattan with natural skin hide bottom

BASKET SHAKERS

The NINO® Basket Shakers contain a special filling for a slightly dampened sound.

Sizes Small
Medium

Material Rattan

GANZA SHAKERS

The NINO® Ganza Shakers produce a voluminous sound due to their size.

Sizes Small
Medium

Material Rattan with coconut bottom

WOOD TAMBOURINES

The NINO® Wood Tambourines feature a sturdy wooden frame along with a nice sparkling sound. They are available in a one row construction with 8 nickel silver jingle pairs, or as a two row model with 16 nickel silver jingle pairs.

Size 10" diameter
Material Jingles: Nickel silver
Wooden frame
Features 1 or 2 row versions available



NIN0501

NIN0703



NIN0522

NIN0521



NIN015

NIN014

HAND PERCUSSION



RACKET TAMBOURINE

The NINO® Racket Tambourines feature a sturdy rattan frame along with a nice sparkling sound. They are available as a one row construction with 9 aluminum jingle pairs. An ergonomically shaped handle makes them perfect for children hands.

Material Frame: Rattan
Jingles: Aluminum
Features Ergonomically shaped and padded handle

NIN0518



WOOD GUIRO SHAKER

The NINO® Wood Guiro Shaker is equipped with a filling and combines a shaker as well as a guiro sound in one instrument.

Material Rubber Wood (*Hevea brasiliensis* Muell.-Arg.)
Features Additional shaker sound
Includes Wooden striker

NIN0520

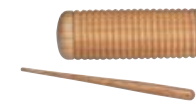

WOOD GUIRO

The guiro is an important instrument which plays a very important part in any percussion set up. Striking the tonal grooves of the NINO® Wood Guiro creates many different sounds.

Material Rubber Wood (*Hevea brasiliensis* Muell.-Arg.)
Includes Wooden striker

NIN0555



CABASAS

The NINO® Cabasa is made from a wooden cylinder covered with a rippled metal plate, which is surrounded by a net of metal beads. Holding the handle with one hand and scratching the metal beads with the other hand on the metal plate creates the classic cabasa sound. The smaller 2" model was especially designed for a child's hand.

Sizes Small
Medium
Material Steel chain and cylinder
Features Ergonomically shaped wooden handle

NIN0701

NIN0702

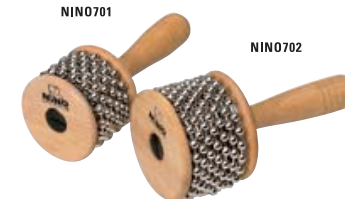

WOODPECKER

The NINO® Woodpecker creates an amazingly realistic „woodpecker“ sound. It's a great effect instrument which is also interesting for professional players who look to increase their sound arsenal.

Material Rubber Wood (*Hevea brasiliensis* Muell.-Arg.)

NEW

NIN0519



SOUNDS LOADED WITH ENERGY

HAND PERCUSSION

CHIMES

The NINO® Chimes can be mounted on a cymbal stand-, or held by the wooden frame. The 12 bars of the NINO® Chimes are made from a premium aluminum alloy and create a very full and rich sound.

Size 12 bars
Material Silver anodized aluminum alloy



NINO600

ENERGY CHIMES

These NINO® instruments have a very cutting "ping" sound. The free floating bars create a very long sustain. NINO® offers three different pitched Energy Chimes, as well as a model with three bars.

Sizes Small
Medium
Large
3 rows
Material Silver anodized aluminum alloy
Includes Wooden beater



NINO580

NINO579L

NINO579M

NINO579S

TRIANGLES

NINO® Percussion offers three tonally matched triangles. They have a strong sound with a long sustain.

Sizes 4"
6"
8"
Material Steel
Features Wooden holder with braided nylon strap
Includes Metal beater with rubber padded grip



NINO552

NINO550

NINO551

A-GO-GO BELL

The NINO® A-Go-Go Bell is perfectly sized for children. It is handmade from high quality steel and produces a loud bell sound.

Material Black powder coated steel



NINO505

JINGLE STICKS

The NINO® Jingle Sticks feature six pairs of nickel silver jingles firmly mounted on a plastic frame with a handle. The jingle stick can be played like a tambourine, or like a drumstick on a conga, bongo, or djembe. New and interesting sounds can be achieved with this instrument.

Material Jingles: Nickel silver
Frame: ABS
Features Ergonomically shaped handle
New sound ideas
Colours BK = Black
R = Red
Y = Yellow



NINO13BK

NINO13R

NINO13Y

MINI FIBERGLASS GUIROS

The NINO® Mini Guiros are made from premium fiberglass. The sound is achieved by scratching the different surfaces of the guiro.

Size Mini
Material Premium fiberglass
Includes Wooden scraper
Colours BK = Black
R = Red



NINO581R

NINO581BK

MINI FIBERGLASS GUIRO SHAKERS

NINO® also offers a Mini Fiberglass Guiro Shaker which combines the sounds of a shaker and a guiro in one instrument.

Size Mini
Material Premium fiberglass
Features Additional shaker sound
Includes Wooden scraper
Colours BK = Black
R = Red



NINO583BK

NINO583R

SOUVENIR INSTRUMENTS

The NINO® Souvenir Instruments are very popular as small gifts or ornaments. They are available as a conga, djembe, or bongo. Great fun for everybody.

Size 3" tall
Material Rubber Wood (*Hevea brasiliensis* Muell.-Arg.)
Features Natural hide skins



NINO511

NINO510

NINO512

CLEAR SOUNDS FROM MODERN MATERIALS

PLASTIC MARACAS

The NINO® Plastic Maracas are known for their stability, versatility, and strong, projecting sound.

Material Plastic
Features Ergonomically shaped handle
 Sold as pairs
Colour R = Red



PLASTIC EGG MARACAS

The NINO® Egg Maracas are made from a special plastic material. They have a very clear and pronounced sound and are perfect maracas for children.

Size 6"
Material Plastic
Features Ergonomically shaped handle
 Sold as pairs
Colour R = Red



BALL SHAKER

The two shakers are firmly attached to each other with a strong cord. By tightly holding one ball and rhythmically swinging the other one, many sounds can be achieved.

Material Plastic
Features Attractive Harlekin® design



EGG SHAKERS

NINO® Egg Shakers are vital to every percussion collection. They have an extremely pronounced and crystal clear sound.

EGG SHAKERS

Material Plastic
Colours B = Blue
 BK = Black
 GR = Green
 R = Red
 Y = Yellow

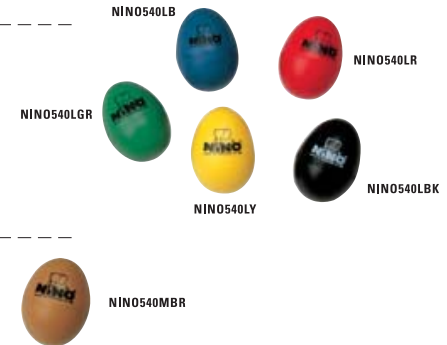

EGG SHAKER, SMALL

Size Small
Material Plastic
Colour BR = Brown



EGG SHAKER ASSORTMENTS

Material Plastic
Sets Egg Shaker Set 4 pcs.
 Egg Shaker Set 80 pcs. including elephant shaped basket



HAND PERCUSSION



FRESH FRUITS AND VEGETABLES

BOTANY SHAKER

The NINO® Botany Shakers are made from a high quality plastic material filled with a specially nice sounding substance. These fruit and vegetable imitations look amazingly real and create a great variety of sounds.

NINO® Botany Shakers have been tested for saliva resistance and can therefore be given to toddlers without any worries.



VE36-NINO536

BOTANY SHAKER ASSORTMENT, 36 pcs.

Material Plastic
Features Botany Shaker Assortment, 36 pcs. incl. 2 baskets of each 18 pcs.

BOTANY SHAKER ASSORTMENT, 4 pcs.

Material Plastic
Features Botany Shaker Assortment, 4 pcs. "fruit"



NINOSET100

BOTANY SHAKER ASSORTMENT, 4 pcs.

Material Plastic
Features Botany Shaker Assortment, 4 pcs. "vegetable"



NINOSET101

BOTANY SHAKER, NINO® SETS



NINO® SETS

NINO® instruments have been designed to meet the demands of early childhood education and are perfectly suitable for the use in kindergartens, schools, music therapy and musical activities in the family. Available are two different NINO® Percussion collections which come in a durable nylon Harlekin® design bag. It's the perfect activity for small groups of up to 8 children.

NINOSET1

Contents 1 x ABS Hand Drum 6"
1 x Wooden Beater
1 x Wood Shaker, large
1 x Skin Maracas pair, small
1 x Jingle Stick
1 x Harlekin® bag
Colours BK = Black
R = Red
Y = Yellow



NINOSET1

NINOSET4

Contents 1 x Wood Guiro
1 x Caxixi
1 x Wood Claves pair, small
1 x Triangle, 4"
1 x Egg Shaker
1 x Egg Shaker, small
1 x Botany Shaker, Banana
1 x Botany Shaker, Apple
1 x Harlekin® bag



NINOSET4

Contents of NINOSET4



SET-THEORY IN A DIFFERENT WAY

NINO® RHYTHM SETS



NINO® RHYTHM SETS

These two NINO® Rhythm Sets include 12 or 15 individual instruments. They are perfect for use in kindergarden, schools, or percussion groups. These collections of different instruments are the ideal way to explore the complete NINO® world of percussion and rhythm.

NINOSSET12

- Contents**
- 1 x Wood Claves pair, large
 - 1 x Triangle, 6"
 - 1 x ABS Hand Drum 10"
 - 1 x Tambourine, one row
 - 1 x Energy Chime, medium
 - 1 x Wood Guiro
 - 1 x Skin Maracas pair, medium
 - 1 x Basket Shaker, medium
 - 2 x Egg Shaker
 - 1 x Wood A-Go-Go, two rows

NINOSSET12



NINOSSET15

- Contents**
- 1 x Wood Claves pair, small
 - 1 x Triangle, 4"
 - 1 x ABS Hand Drum 6"
 - 1 x Mini Fiberglass Guiro
 - 1 x Skin Egg Shaker
 - 1 x Egg Maracas pair, small
 - 1 x Basket Shaker, small
 - 1 x Wood Shaker Assortment 3 pcs., square
 - 1 x Wood-Block, medium
 - 1 x Botany Shaker, Banana
 - 1 x Egg Shaker
 - 1 x Jingle Stick
 - 1 x Basket

NINOSSET15



PRECIOUS METAL BROUGHT TO SOUND

CYMBALS

These excellent sounding NINO® Cymbals are made in Germany. They are a high quality product and perfect for music education. They are tonally matched to create a triad when played at the same time.

- Sizes** 12" / 30,5 cm
13" / 33,0 cm
14" / 35,5 cm
- Material** Nickel silver
- Features** Tonally matched
- Includes** Leather strap



CYMBAL PAIRS

NINO® Cymbal Pairs are made in Germany from premium alloys. Different sizes are available in bronze, brass, or nickel silver. All cymbal pairs are tonally matched and are equipped with a leather strap.

- Sizes** 6" / 15,0 cm
7" / 17,5 cm
8" / 20,0 cm
- Material** Bronze, brass, or nickel silver pairs
- Includes** Leather straps



CHINA GONG

Children love the NINO® Tenor Gong which is hand made from a special alloy. Its smooth and relaxing tone reveals magic.

- Size** 12"
- Material** Special alloy
- Features** Smooth and relaxing tone
- Includes** Holder
Beater



MUSIC BAGS

Handy bags made from durable nylon are always useful. This NINO® Music Bag is available in red and the Harlekin® design. Many separate compartments make it ideal for all kind of activities.

- Material** Nylon
- Features** Many compartments
- Colours** HK = Harlekin
R = Red



CYMBALS, BAGS



SPARE PARTS

Our spare part service has original NINO® heads and lugs for congas, djembes, bongos available separately. Mechanical spare parts for NINO® instruments are also available.

HEADS	
HEAD-NI910-9	9" for conga (NINO910)
HEAD-NI910-10	10" for conga (NINO910)
HEAD-NIN089-8	8" for conga (NINO89)
HEAD-NIN089-9	9" for conga (NINO89)
HEAD-NIN023	10" for djembe
HEAD-NIN03-65	6 1/2" for bongo (NIN03 / NIN017)
HEAD-NIN03-75	7 1/2" for bongo (NIN03 / NIN017)
TUNING LUG	
LUG-NIN0910	Lug for conga (NINO910)
LUG-NIN089	Lug for conga (NINO89)
LUG-NIN023	Lug for djembe (NIN023)
LUG-NIN03	Lug for bongo (NIN03 / NIN017)
BEATERS	
NIN09	Wood beater
NIN0567	Metal beater



SIGN IN & WIN

For more information about MEINL percussion products, endorsing artists, tips'n tricks around percussion, exclusive video footage and mp3 downloads, please log on to meinlpercussion.com

SIGN IN & WIN

Take part in the monthly MEINL percussion give away by simply subscribing to the official MEINL Newsletter and receive site updates, product news, clinic and tour dates, exclusive artist updates, and much more.

Every month MEINL gives away valuable prizes to the winner of the monthly contest. For more details please check out

meinlpercussion.com

