



2007
THE MEINL BOOK OF PERCUSSION

PASSION FOR DETAILS





DIRECTORY

PRODUCT GROUP	PAGE
CONGAS	2
DJEMBES	30
BONGOS	44
CAJONS	58
TIMBALES	74
SAMBA	84
SHAKERS	98
STEELBELLS	102
TAMBOURINES	105
CLAVES	107
CHIMES	108
TRIANGLES	110
CABASAS	111
BLOCKS	112
GUIROS	112
MARACAS	113
EGG SHAKERS	113
RITUAL DRUMS	114
SHEKERES	116
IBO DRUMS	118
DOUMBEKS	120
DARBUKAS	122
DANCING DRUMS	124
HARDWARE	126
CANDELA CYMBALS	130
NINO	133
MERCHANDISE	160

MEINL PERCUSSION – PASSION FOR DETAILS

After 29 years of making instruments we've learned that no detail is too small. Every part adds up to making the instrument better. Better sound, more durable or more professional appearance. When it comes to crafting instruments we are always looking for ways to make them better. For example, before MEINL Cajons there was either a Peruvian or Flamenco style, but never both combined like our cajons with adjustable snare sound. For shakers, we have no limit. Think of the first tunable shaker invented... the Spark. Or the Wah Wah shaker. Before MEINL Ibos, only fragile ceramic drums were available – now we offer more durable fiberglass and wood ibos. For congas, think of our patented Floatune system, invented to have a freely resonating shell, with no hardware bolted to it. Our Free Ride Bongos allow for a shell free of hardware also. The height adjustable Steely II stand features many innovations from L-shaped legs to ergonomic arched rubber bracings. There are examples like this for every type of percussion instrument we make.

How do we do it? One simple word, Passion. **We have a Passion for Details.**

MEINL MERCHANDISE

Support your favourite percussion brand with the official MEINL swag. A selection of exclusive items made from the highest quality materials.

KEY CHAINS

NEW

Colours Black, Blue, Green, Orange, Red, Silver



M75

POLO SHIRT

Sizes M, L, XL, XXL
Colour Black
Front MEINL logo, small



M25

Front only

TRAINING JACKET

NEW

Sizes M, L, XL
Colour Black
Front MEINL logo, small
Back MEINL logo, big



M73

Front

Back

LONGSLEEVE T-SHIRT

Sizes S, M, L, XL, XXL
Colour Black
Front MEINL logo, small
Back MEINL logo, big



M45

Front

Back

SWEAT SHIRT

Sizes S, M, L, XL, XXL
Colour Black
Front MEINL logo, small
Back MEINL logo, big



M49

Front

Back

LANYARD



M35

MOUSE PAD "CONGA HEAD"

M51



FRISBEE DISC

M52



LONG SLEEVE W. RED ARMS

NEW

Sizes M, L, XL
Colour Black/Red
Front MEINL logo, small
Back MEINL logo, big



M74

Front

Back

HOOD SHIRT W. ZIPPER

Sizes S, M, L, XL, XXL
Colour Black
Front MEINL logo, small
Back MEINL logo, big



M48

Front

Back

T-SHIRT

Sizes S, M, L, XL, XXL
Colour Black
Front MEINL logo, small
Back MEINL logo, big



M42

Front

Back

SIGN IN AND WIN

Take part in the monthly MEINL PERCUSSION give away by simply subscribing to the official MEINL Newsletter and receive site updates, product news, clinic and tour dates, exclusive updates, and much more. Every month MEINL gives away valuable prizes to the winner of the monthly contest. For more details please check out

meinlpercussion.com

For more information about MEINL percussion products, endorsing artists, tips'n tricks around percussion, exclusive video footage and mp3 downloads, please log on to meinlpercussion.com

IMPRESSUM

All features are subject to change without notice. Not responsible for typographic errors. No part of this book may be reprinted, reproduced or included in any online service in any form in whole or in part, without the prior written permission of MEINL.
© 2007 Roland Meinl Musikinstrumente GmbH & Co. KG

Advertising Concept & Design by:
infowerk ag

Content & Direction by:
Udo Heubeck, Mario Schmitt

Photos by:
Studio Waldeck, Markus Buberl, Biggi Sauer, Luis de Miguel, Rick Malkin, Scott Saltzman, Alex Solca, Andrea Meister, James Cumpsty, Sean Vennet, Ludek Neuzil, Mario Rath

MEINL would like to thank:
Storymaker, www.storymaker.de
Klaus Haberecker, www.ergotherapie-haberecker.de
Markus Buberl, www.triebwerk.net

MEINL GLOBAL HEADQUARTER
Am Bahnhof 2
91468 Gutenstetten
GERMANY

MEINL USA L.C.
3300 Ambrose Avenue
Nashville, TN 37207
USA

Printed in Germany M-CA301206



meinlpercussion.com





CONGAS

MIPA AWARD FOR MEINL PROFESSIONAL SERIES AND MEINL ARTIST SERIES LUIS CONTE CONGAS

The "Musikmesse International Press Award" is annually presented by 55 music magazines from all over the world that get together and vote for the best products in certain categories.

In the category "Best Percussion Product," MEINL Congas have won the MIPA Award twice.



WOODCRAFT SERIES

The MEINL Woodcraft Series Congas stand for tradition combined with exceptional workmanship. Only the finest hand selected materials are used to produce these premium drums. Their "Cuban Style" shaped shells provide a broad range of different tonal characteristics. It blends warm bass tones, soft open tones, and sharp slaps into one powerful drum and at the same time yields extraordinary projection.



Sizes 11" Quinto, 11 3/4" Conga, 12 1/2" Tumba 30" tall

Material Two ply American White Ash (*Fraxinus americana* L.)

Features True Skin Buffalo Heads
10 mm strong tuning lugs
4 mm traditional TTR-Rims
Chrome plated hardware

Includes MEINL Conga Saver (patented)
MEINL Soundpads
Accessory pouch
L-shaped tuning key
Tune Up Oil

Colour ZFA-M = Zebra Finished Ash

Finish Matt



Two ply American White Ash (*Fraxinus americana* L.)

FLOATUNE SERIES

The Floatune Tuning System is a true and unique MEINL innovation. All mounting hardware is completely isolated from the shell and is secured without any drilling which allows the shell to vibrate freely.



Sizes 10" Nino, 11" Quinto, 12" Conga, 13" Tumba 30" tall

Material Two ply Rubber Wood (*Hevea brasiliensis* Muell.-Arg.)

Features Floatune Tuning System
True Skin Buffalo Heads
10 mm strong tuning lugs
4 mm rounded SSR-Rims
Chrome plated hardware

Includes MEINL Conga Saver (patented)
MEINL Soundpads
Accessory pouch
L-shaped tuning key
Tune Up Oil

Colour NT = Natural

Finish Hi Gloss



ARTIST SERIES

Mongo Santamaria

Ramon "Mongo" Santamaria was without a doubt one of the most respected conga players ever and a pioneer of modern Latin Jazz. During the 50's his band "Black Cuban Diamonds" laid down the foundation for an outstanding career.

He has recorded dozens of legendary percussion albums. Worldwide Jazz hits, such as "Watermelon Man" in 1963 and the album "Summertime" from 1980 are only two of the many recordings from this great master percussionist. Mongo has inspired more percussionists around the globe than any other conguero.

Mongo Santamaria died at the Baptist Hospital in Miami, USA in February 2003. He was 85 years old. It is with great appreciation and deepest respect that we honour our friend and his life's work with his MEINL Artist Series Mongo Santamaria Congas.



Ramon "Mongo" Santamaria, Cuba



Sizes 11" Quinto, 11 3/4" Conga, 12 1/2" Tumba 30" tall
Material Two ply American White Ash (*Fraxinus americana* L.)
Features True Skin Buffalo Heads
 10 mm strong tuning lugs
 4 mm rounded SSR-Rims
 Gold tone hardware

Includes MEINL Conga Saver (patented)
 MEINL Soundpads
 Accessory pouch
 L-shaped tuning key
 Tune Up Oil
Colour AWA = American White Ash
Finish Hi Gloss



Two ply American White Ash (*Fraxinus americana* L.)

SPECIAL EDITION ARTIST SERIES

As a special tribute to our friend and inspiration, the legendary Mongo Santamaria, MEINL offers the Special Edition Artist Series Mongo Santamaria Congas. Made with dedication, from only the finest hand selected materials, these drums sound as original and musical as their mentor. Mongo Santamaria and the MEINL Special Edition Artist Series Congas – a legendary combination.



Two ply American White Ash (*Fraxinus americana* L.)

Sizes 11" Quinto, 11 3/4" Conga, 12 1/2" Tumba 30" tall
Material Two ply American White Ash (*Fraxinus americana* L.)
Features True Skin Buffalo Heads
 10 mm strong tuning lugs
 4 mm rounded SSR-Rims
 Chrome plated hardware

Includes MEINL Conga Saver (patented)
 MEINL Soundpads
 Accessory pouch
 L-shaped tuning key
 Tune Up Oil
Colour ZFA-M = Zebra Finished Ash
Finish Matt



FIBERCRAFT SERIES

MEINL Fibercraft Congas offer great quality, durability, volume, and the resistance to climatic changes. They have a great presence and brilliancy in sound. Great for live playing and extensive road use.



Extraordinary sparkling effect

Sizes 11" Quinto, 11 3/4" Conga, 12 1/2" Tumba

Material Premium fiberglass

Features True Skin Buffalo Heads
10 mm strong tuning lugs
4 mm rounded SSR-Rims
Chrome plated hardware

Includes MEINL Conga Saver (patented)
MEINL Soundpads
Accessory pouch
L-shaped tuning key
Tune Up Oil

Colours BKSP = Black Sparkle
BSP = Blue Sparkle
RSP = Red Sparkle



MEINL CONGA SAVER PATENTED



PROFESSIONAL SERIES

Roland Meinl

The Roland Meinl Professional Series Congas – one of the finest instruments in the MEINL Percussion program and the preferred conga model by many top congueros. Outstanding in look and sound reaching from fat basses to cutting slaps with a great warm overall tone. They have set the standard in the professional conga ranges.



MP11NT

MP1134NT

MP1212NT



Chrome plated 4mm rounded SSR-Rim



MP11ARF

MP1134ARF

MP1212ARF



MP11BB

MP1134BB

MP1212BB



MP11EBK

MP1134EBK

MP1212EBK



Sizes 11" Quinto, 11 3/4" Conga, 12 1/2" Tumba
30" tall

Material Two ply Rubber Wood (Hevea brasiliensis Muell.-Arg.)

Features True Skin Buffalo Heads
10 mm strong tuning lugs
4 mm rounded SSR-Rims
Chrome plated hardware

Includes MEINL Conga Saver (patented)
MEINL Soundpads
Accessory pouch
L-shaped tuning key
Tune Up Oil

Colours ARF = Aztec Red Fade
BB = Brown Burl
EBK = Ebony Black
NT = Natural

Finish Hi Gloss





ARTIST SERIES

Luis Conte

Grammy-winner Luis Conte is an acknowledged master of percussion. His celebrated career includes touring and/or recording with some of the greatest names in contemporary music, including Madonna, Eric Clapton, Santana, Céline Dion, Barbara Streisand, Backstreet Boys, Ray Charles and Cuban legends Arturo Sandoval and Cachao. He can also be heard on the scores and/or soundtracks to movies such as Mission Impossible, Rain Man, Disney's animated Tarzan and many more.

Luis began 2006 by playing at the Grammy Awards with musical director Patrice Rushen and performed with James Taylor (as person of the year) in a concert where he had to back guest artists such as Bonnie Raitt, Dixie Chicks, Paul Simon, Bruce Springsteen and Dr. John.

The year continued with a clinic tour throughout the Midwestern US.

While not on tour, Luis has been busy in Los Angeles appearing on a variety of recordings, such as jingles (TV commercials), movie soundtracks such as Miami Vice, Smoking Aces and The Lost City and on albums such as Five for Fighting, OK Go, Michael W Smith, Michael Bolton, Russell Watson, Pussy Cat Dolls, Ziggy Marley, Marco Antonio Solis, Aly and AJ, Slumber Party Girls and many more.

Besides an Australian tour with Jackson Browne and concerts with the great R&B Soul and Gospel Diva Patti Labelle, Luis also performed in Christian concerts with Dámaris Carbaugh, Bill Cantos and the City of Angels Orchestra.

If this wasn't enough, Luis also jammed at the Andre Agassi Celebrity Benefit concert in Las Vegas with Phil Collins, Christina Aguilera and Tears For Fears.

During the summer months, Luis gave an extensive clinic tour which took him to Switzerland, Portugal, Spain, the Netherlands, Belgium, France, Turkey, the Czech Republic, England, Sardinia and Italy where he performed in front of several thousand enthused visitors.

His next triumph was an incredible duet with Thomas Lang at the Modern Drummer Festival in Newark, NJ. Luis and Thomas convened on the New Jersey Performing Arts Center with many other lovers of all things drumming to give a performance which many will remember for years to come.

Luis has also been touring with his own band around Los Angeles and Santa Barbara Counties and is currently working on his next solo CD which will be released sometime in 2007.



Black powder coated
4 mm traditional TTR-Rim



LC11NT-M

LC1134NT-M

LC1212NT-M

Rubber ringed bottom
for more stability and
protection

All of Luis' needs have been met and exceeded with the MEINL Artist Series Luis Conte Signature Congas. They combine the charm and sound of the old traditional Cuban drums with modern features and innovations. The congas are equipped with traditional rims, are mounted as close to the shell as possible, and when combined with MEINL's True Skin Buffalo Heads, they enable an even more controlled sound.

Sizes	11" Quinto, 11 3/4" Conga, 12 1/2" Tumba 30" tall	Includes	MEINL Conga Saver (patented) MEINL Soundpads Accessory pouch L-shaped tuning key Tune Up Oil
Material	Two ply Rubber Wood (<i>Hevea brasiliensis</i> Muell.-Arg.)	Colour	NT-M = Natural
Features	True Skin Buffalo Heads 8 mm strong tuning lugs 4 mm traditional TTR-Rims Black powder coated hardware	Finish	Matt

STEELY II CONGA STAND (patented)

Once again, MEINL percussion has taken an already advanced product to the next level. Besides its revolutionary features such as 90° angled legs for more stability, metal spikes attached to the bottom of every leg to prevent movement, U-shaped notches built into the ring for quick set up and breakdown, system for faster height adjustability is established and new ergonomic arched rubber bracings for more stability have now been introduced. It allows for quicker and completely stress free adjustments pertaining to the player's individual needs. The new MEINL Steely II Conga Stands (patented) are available for all MEINL Professional Range Congas.



U-shaped notch allows quick set up and breakdown (patent pending)

Metal spike attachment (patented)



New ergonomic arched rubber bracing for more stability

IMPROVED

Quick and easy height adjustability (patent pending)



L-shaped leg (patented)

MARATHON® CLASSIC SERIES

The MEINL Marathon® Classic Series Congas set the standard in this price range by which other wood congas are judged. They combine professional features at a very attractive price.



Black powder coated 2.6 mm rounded SSR-Rim



NEW



See page 14/15 for detailed information



MCC11CB

MCC1134CB

MCC1212CB

Sizes 11" Quinto, 11 3/4" Conga, 12 1/2" Tumba
30" tall

Material Two ply Rubber Wood
(*Hevea brasiliensis* Muell.-Arg.)

Features True Skin Buffalo Heads
8 mm strong tuning lugs
2.6 mm rounded SSR-Rims
Black powder coated hardware

Includes Steely II Conga Stand (patented)
MEINL Conga Saver (patented)
Accessory pouch
L-shaped tuning key
Tune Up Oil

Colours CB = Coffee Burst, hi gloss
SNT-M = Super Natural, matt
TSR-M = Tequilla Sunrise, matt

IMPROVED



MCC11SNT-M

MCC1134SNT-M

MCC1212SNT-M



MCC11TSR-M

MCC1134TSR-M

MCC1212TSR-M

HEADLINER® SERIES

11" & 12" WOOD CONGA SETS

The 11" & 12" pair is a full-sized entry level conga set. With superb projection, warm tones, a light weight and features found on professional congas, they offer outstanding quality and great value in the budget price range. This is a pair of congas you will want to keep around as you develop your skills.



Sizes 11" & 12" Conga Set
28" tall

Material Rubber Wood
(*Hevea brasiliensis* Muell.-Arg.)

Features Hand selected buffalo heads
8 mm strong tuning lugs
Original MEINL style tuning brackets
2 mm rounded rims
Black powder coated hardware

Includes HC812: Height adjustable double braced tripod stand
HC512: Height adjustable basket stands with quick set up system
Tuning key

Colours MA = Maple
NT = Natural
VSB = Vintage Sunburst
WR = Wine Red

Finish Hi Gloss



HEADLINER® SERIES

10" & 11" WOOD CONGA SETS

The 10" & 11" pair is the perfect set of congas to get you started. The compact size is easy for young players to handle, light to carry and has a full, rich sound. You can develop a full foundation of conga techniques and rhythms with these student-friendly drums. Professional sounding congas at a great price.



HC888NT



HC888WR



Original MEINL style tuning bracket

Black powder coated 2 mm rounded rim

Rubber ringed bottom for more stability and protection

- Sizes** 10" & 11" Conga Set
28" tall
- Material** Rubber Wood
(*Hevea brasiliensis* Muell.-Arg.)
- Features** Hand selected buffalo heads
8 mm strong tuning lugs
Original MEINL style tuning brackets
2 mm rounded rims
Black powder coated hardware

- Includes** HC888: Height adjustable double braced tripod stand
HC555: Height adjustable basket stands with quick set up system
Tuning key
- Colours** BK = Black
NT = Natural
VSB = Vintage Sunburst
WR = Wine Red
- Finish** Hi Gloss



HC555VSB



Height adjustable



HC555BK

U-shaped notch allows quick set up and breakdown (patent pending)



L-shaped leg (patented)



STEELY II CONGA STANDS (patented)

The MEINL Steely II Conga Stands (patented) are available for all MEINL Professional Series Congas.

IMPROVED
New ergonomic arched rubber bracing for more stability

U-shaped notch allows quick set up and breakdown (patent pending)



L-shaped leg and metal spike attachment (patented)

Quick and easy height adjustability (patent pending)

MODELS:

For Marathon® Classic Series Congas
For Luis Conte Artist Series Congas

ST-MCC11BK	11"	Black powder coated
ST-MCC1134BK	11 3/4"	Black powder coated
ST-MCC1212BK	12 1/2"	Black powder coated

For Floatune Series Congas

ST-FL10CH	10"	Chrome plated
ST-FL11CH	11"	Chrome plated
ST-FL12CH	12"	Chrome plated
ST-FL13CH	13"	Chrome plated

For Professional Series Congas

For Fibercraft Series Congas

For Special Edition Mongo Santamaria Artist Series Congas

ST-MP11CH	11"	Chrome plated
ST-MP1134CH	11 3/4"	Chrome plated
ST-MP1212CH	12 1/2"	Chrome plated

For Mongo Santamaria Artist Series Congas

ST-MSA11G	11"	Gold tone
ST-MSA1134G	11 3/4"	Gold tone
ST-MSA1212G	12 1/2"	Gold tone

For Woodcraft Series Congas

ST-WC11CH	11"	Chrome plated
ST-WC1134CH	11 3/4"	Chrome plated
ST-WC1212CH	12 1/2"	Chrome plated

Material Steel
Features Patented designs
Metal spike attachment on each leg
L-shaped legs
U-shaped notch for quick set up and breakdown
Notches for quick height adjustability
Includes Allen wrench

STEELY II CONGA STAND HEIGHT EXPANDER SET (patent pending)

Those innovative add-ons to the MEINL Steely II Conga Stands (patented) allow an easy and effective height extension in order to allow a more comfortable playing position for taller congueros.

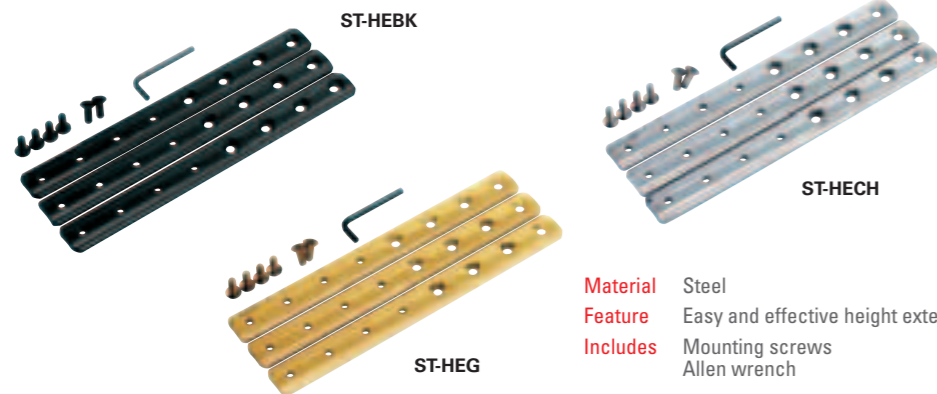

Material Steel
Feature Easy and effective height extension
Includes Mounting screws
Allen wrench



Easy and effective height extension

Finishes Black powder coated
Chrome plated
Gold tone

PROFESSIONAL CONGA STAND

The MEINL Conga Stand is unique with respect to design and function. It was especially developed to accommodate the rigors of professional road use where fine adjustment and durability are demanded. It is fully height adjustable and securely fixed by means of the three legs of the stand.

Compatible for all sizes



The lightweight stand can be folded to a compact unit which requires little space

Material Chrome plated steel
Features Unique design
Rubber padded crossbeams
Fully height adjustable
Folds up to a compact unit

Includes Allen wrench
Memory locks



TMC-CH

PROFESSIONAL CONGA BAGS

The MEINL Conga Bags come in three sizes: Quinto, Conga, and Tumba. An additional upright zipper simplifies packing and unpacking of your drum. Additional features are padded backpack straps and an external pocket for accessories.



Additional upright zipper

Sizes 11"
11 3/4"
12 1/2"

Material Heavy duty padded nylon



MCOB-11

Padded backpack strap

MCOB-1134

MCOB-1212

Carrying grip

Features Additional upright zipper
External pocket
Padded backpack straps
Carrying grip

CONGAS

Model No.	Size	Height	Material	Features	SPARE PARTS					Page		
					Head	Rim	Lug	Bracket				
WOODCRAFT SERIES												
WC11	11"	30"	•	•	•	•	•	TS-B-44	TTR-23	LUG-01	BRACKET-14	4
WC1134	11 3/4"	30"	•	•	•	•	•	TS-B-45	TTR-24	LUG-01	BRACKET-14	4
WC1212	12 1/2"	30"	•	•	•	•	•	TS-B-46	TTR-25	LUG-01	BRACKET-14	4
FLOATUNE SERIES												
FL10	10"	30"	•	•	•	•	•	TS-B-01	SSR-06	LUG-01		5
FL11	11"	30"	•	•	•	•	•	TS-B-03	SSR-07	LUG-01		5
FL12	12"	30"	•	•	•	•	•	TS-B-15	SSR-12	LUG-01		5
FL13	13"	30"	•	•	•	•	•	TS-B-21	SSR-15	LUG-01		5
ARTIST SERIES, Mongo Santamaria												
MSA11AWA	11"	30"	•	•	•	•	•	TS-B-07	SSR-08	LUG-02	BRACKET-16	6
MSA1134AWA	11 3/4"	30"	•	•	•	•	•	TS-B-11	SSR-10	LUG-02	BRACKET-16	6
MSA1212AWA	12 1/2"	30"	•	•	•	•	•	TS-B-17	SSR-13	LUG-02	BRACKET-16	6
SPECIAL EDITION ARTIST SERIES, Mongo Santamaria												
MSA112FA-M	11"	30"	•	•	•	•	•	TS-B-07	SSR-37	LUG-01	BRACKET-14	7
MSA1134ZFA-M	11 3/4"	30"	•	•	•	•	•	TS-B-11	SSR-38	LUG-01	BRACKET-14	7
MSA1212ZFA-M	12 1/2"	30"	•	•	•	•	•	TS-B-17	SSR-39	LUG-01	BRACKET-14	7
FIBERCRAFT SERIES												
FC11	11"	30"	•	•	•	•	•	TS-B-34	SSR-22	LUG-01	BRACKET-14	8/9
FC1134	11 3/4"	30"	•	•	•	•	•	TS-B-35	SSR-23	LUG-01	BRACKET-14	8/9
FC1212	12 1/2"	30"	•	•	•	•	•	TS-B-36	SSR-24	LUG-01	BRACKET-14	8/9
PROFESSIONAL SERIES												
MP11	11"	30"	•	•	•	•	•	TS-B-34	SSR-22	LUG-01	BRACKET-14	10/11
MP1134	11 3/4"	30"	•	•	•	•	•	TS-B-35	SSR-23	LUG-01	BRACKET-14	10/11
MP1212	12 1/2"	30"	•	•	•	•	•	TS-B-36	SSR-24	LUG-01	BRACKET-14	10/11
ARTIST SERIES, Luis Conte												
LC11	11"	30"	•	•	•	•	•	TS-B-52	TTR-28	LUG-03	BRACKET-20	13
LC1134	11 3/4"	30"	•	•	•	•	•	TS-B-53	TTR-29	LUG-03	BRACKET-20	13
LC1212	12 1/2"	30"	•	•	•	•	•	TS-B-54	TTR-30	LUG-03	BRACKET-20	13
MARATHON® CLASSIC SERIES												
MCC11	11"	30"	•	•	•	•	•	TS-B-38	SSR-25	LUG-03	BRACKET-15	16/17
MCC1134	11 3/4"	30"	•	•	•	•	•	TS-B-39	SSR-26	LUG-03	BRACKET-15	16/17
MCC1212	12 1/2"	30"	•	•	•	•	•	TS-B-40	SSR-27	LUG-03	BRACKET-15	16/17
HEADLINER® SERIES WOOD CONGA SETS												
HC812 (incl. double stand)	11" + 12"	28"	•					HHEAD11/HHEAD12C	HRIM11/HRIM12C	HCLUG	HCBRACKET-02	18
HC512 (incl. basket stands)	11" + 12"	28"	•					HHEAD11/HHEAD12C	HRIM11/HRIM12C	HCLUG	HCBRACKET-02	19
HC888 (incl. double stand)	10" + 11"	28"	•					HHEAD10/HHEAD11	HRIM10/HRIM11	HCLUG	HCBRACKET-02	20
HC555 (incl. basket stands)	10" + 11"	28"	•					HHEAD10/HHEAD11	HRIM10/HRIM11	HCLUG	HCBRACKET-02	21

SPARE PARTS FOR STANDS		
Double Stand for HC888/HC812	HDSTAND	18/20
10" Basket for HC555	HSTAND10	21
11" Basket for HC555/HC512	HSTAND11	19/21
12" Basket for HC512	HSTAND12	19
Rubber Feet (set of 3 pcs.) for Steely-II Stand	STAND-35	22
Rubber Tops (set of 3 pcs.) for Steely-II Stand	STAND-21	22
Screw Set complete for Steely-II Stand, black	STAND-22	22
Screw Set complete for Steely-II Stand, chrome	STAND-23	22
Screw Set complete for Steely-II Stand, gold tone	STAND-24	22
Socket Screw (set of 2 pcs.) black	STAND-26	22
Socket Screw (set of 2 pcs.) chrome	STAND-27	22
Socket Screw (set of 2 pcs.) gold tone	STAND-28	22

OTHER PARTS		
Lug Oil	SPARE-09	
Conga Saver for 8mm Lugs (set of 6 pcs.)	CONGA-SAVER8	
Conga Saver for 10mm Lugs (set of 6 pcs.)	CONGA-SAVER10	
Tuning Key, 13mm + 14mm, L shaped, gold tone	KEY-01	
Tuning Key, 13mm + 14mm, L shaped, chrome	KEY-02	
Tuning Key, 14mm, chrome	KEY-03	
Tuning Key, 13mm, chrome	KEY-04	

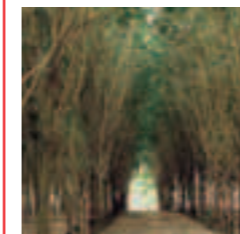

RUBBER WOOD

(*Hevea brasiliensis* Muell.-Arg.)

The traditional plantation of rubber wood (*Hevea brasiliensis* Muell.-Arg.) in Thailand meets all ecological requirements. In a natural evolution, new trees are planted and the older ones, which have ceased to provide latex, are harvested. In this way, plenty of raw material is available and the valuable rain forest eco-system is preserved. In addition to rubber wood (*Hevea brasiliensis* Muell.-Arg.), we also utilize American White Ash (*Fraxinus americana* L.) which meets all the CITES-regulations set in the "Convention on International Trade in Endangered Species of Wild Fauna and Flora."



FIBERGLASS

Many percussionists prefer the sound of fiberglass instead of wood, because fiberglass produces a more compact sound with an appealing spectrum of overtones. Premium fiberglass is manufactured by hand laminating layer upon layer which requires extreme patience and dexterity. The result is a truly professional instrument with a unique sound quality.



TRUE SKIN BUFFALO HEADS

MEINL True Skin Buffalo Heads are without a doubt the perfect choice for both wood and fiberglass congas due to their structure, thickness, and sonic characteristics. True Skin hides are selected by specialists. After the selection process, each skin is gently tanned using a special MEINL procedure and then mounted by hand to become a first class True Skin Head.



SSR

The MEINL Safe & Sound-Rim (SSR) for congas features a rounded profile to support a comfortable playing feel and prevents palm injuries.



TTR

The MEINL Traditional-Tuning-Rim (TTR) for congas represents the traditional "Cuban Style." It is narrowly placed around the shell and enhances the overall conga sound.



CONGA SAVER

The patented Conga Saver is truly a MEINL innovation. Available in 8mm and 10mm versions, they are placed over the conga lugs to prevent them from damaging and scratching the shell while the conga remains fully tunable.





Mario "Mafisto" Zöller,
synchronisation system engineer

Petra Öhrlein,
industrial clerk

Carina Strenz,
flight attendant

DJEMBES

Carina Strenz:

"I love to meet with friends and make music, because rhythm feeds my soul. Drumming makes me feel really energized and relaxed at the same time. It's a very rewarding experience and a lot of fun too! Sometimes we play traditional rhythms that we learned, and sometimes we make them up. The more we explore, the deeper it takes us, on a never-ending journey ... I could do this forever!"

FLOATUNE SERIES 12 3/4" WOOD DJEMBES (patented)

The 12 3/4" MEINL patented Floatune Djembe is modeled after the West African originals. Deep, round-sounding bass notes complimented by crisp tones and slaps are produced by the projection of this drum. A common drum known for its dynamic sounds and the most widely used African drum today.



Size 12 3/4"
25 1/4" tall

Material Rubber Wood
(*Hevea brasiliensis* Muell.-Arg.)

Features True Skin Goat Heads
8 mm strong tuning lugs
3 mm rounded SSR-Rims
Easy tuning and comfortable change of heads
Rubber pads and relocated lugs offer perfect playing comfort
Patented Floatune Tuning System
Chrome plated hardware

Includes Accessory pouch
L-shaped tuning key
Tune Up Oil

Colours AB-M = African Brown, matt
GAB = Gold Amber Sunburst, hi gloss
NT = Natural, hi gloss
SNT-M = Super Natural, matt

The head can be tuned very simply

FLOATUNE SERIES 12" WOOD DJEMBES (patented)

The 12" MEINL patented Floatune Djembe is modeled after the West African originals. The proportions of this drum provide higher, brighter tones and slaps, while retaining a clear, full bass note. This model is a bit more compact and lighter in weight.



Size 12"
24 1/4" tall

Material Rubber Wood
(*Hevea brasiliensis* Muell.-Arg.)

Features True Skin Goat Heads
8 mm strong tuning lugs
3 mm rounded SSR-Rims
Easy tuning and comfortable change of heads
Rubber pads and relocated lugs offer perfect playing comfort
Patented Floatune Tuning System
Chrome plated hardware

Includes Accessory pouch
L-shaped tuning key
Tune Up Oil

Colours AB-M = African Brown, matt
GAB = Gold Amber Sunburst, hi gloss
NT = Natural, hi gloss
SNT-M = Super Natural, matt

FLOATUNE SERIES WOOD DJEMBE (patented)

The MEINL patented Floatune Wood Djembe is made from finest American White Ash (*Fraxinus americana* L.) which produces an excellent voluminous djembe sound.

American White Ash
(*Fraxinus americana* L.)



SSR
Safe & Sound-Rim
MEINL
Chrome plated
3 mm rounded
SSR-Rim



DJW3ZFA-M

- Size** 12"
24 1/4" tall
- Material** American White Ash
(*Fraxinus americana* L.)
- Features** True Skin Goat Head
8 mm strong tuning lugs
3 mm rounded SSR-Rim
Easy tuning and comfortable change of heads
Rubber pads and relocated lugs offer perfect playing comfort
Patented Floatune Tuning System
Chrome plated Hardware

- Includes** Accessory pouch
L-shaped tuning key
Tune Up Oil
- Colour** ZFA-M = Zebra Finished Ash
- Finish** Matt

FLOATUNE SERIES FIBERGLASS DJEMBES (patented)

The MEINL patented Floatune Series Fiberglass Djembes are truly a sound alternative. Fiberglass has enormous strength and can produce slaps of outstanding transparency and immensely powerful bass tones.

Extraordinary sparkling effect

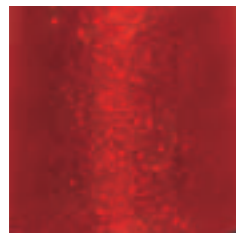

SSR
Safe & Sound-Rim
MEINL
Chrome plated
3 mm rounded
SSR-Rim

FLOATUNE
TUNING SYSTEM



DJF3RSP

DJF3BSP

- Size** 12"
24 1/4" tall
- Material** Premium fiberglass
- Features** True Skin Goat Heads
8 mm strong tuning lugs
3 mm rounded SSR-Rims
Easy tuning and comfortable change of heads
Rubber pads and relocated lugs offer perfect playing comfort
Patented Floatune Tuning System
Chrome plated hardware

- Includes** Accessory pouch
L-shaped tuning key
Tune Up Oil
- Colours** BSP = Blue Sparkle
RSP = Red Sparkle

PATENTED FLOATUNE TUNING SYSTEM

The patented Floatune Tuning System is a great innovation in drum technology. It is essentially a ring-harness and connecting hardware that floats on the outside of the drum shell. This allows the head to be secured and tuned without the need to drill bolt-holes through the shell. Excessive hardware mounted on the shell can have an undesirable effect on the drum's resonance. Anything that interferes with the vibration of the shell is actually reducing the full potential of the drum. The more freely the shell vibrates, the more pronounced and developed the fundamental sound characteristics will be.

The vibration of the shell is a very important component of the drum's fundamental sound

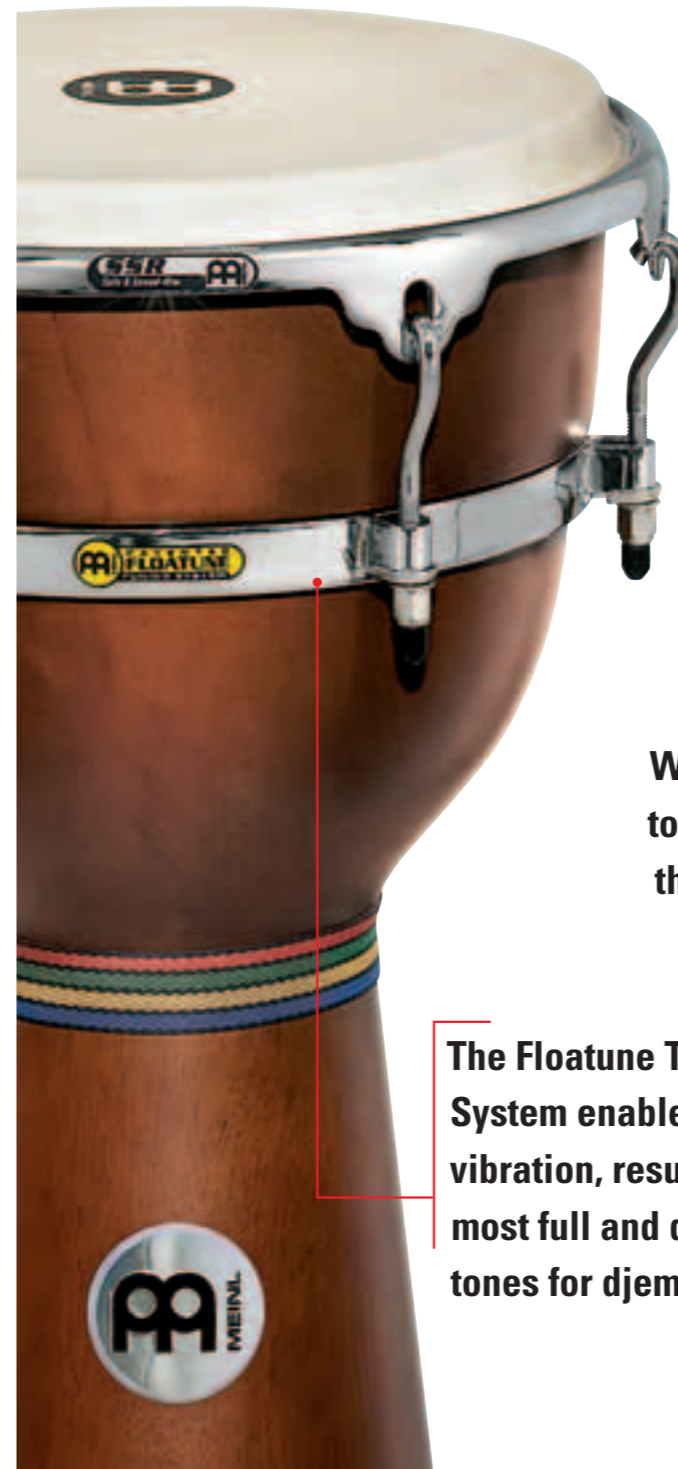

Without the need to drill bolt-holes through the shell

The Floatune Tuning System enables maximum vibration, resulting in the most full and developed tones for djembes

PASSION FOR DETAILS

ROPE TUNED WOOD DJEMBES

The MEINL Rope Tuned Wood Djembes are crafted with great attention to detail. They feature the traditional rope tuning system. A great sounding drum at an affordable price.



Traditional rope tuning system

DJWR3AB-M

DJWR3SNT-M

DJWR3NT-M

- | | | | |
|-----------------|---|----------------|---|
| Size | 12"
24 1/4" tall | Colours | AB-M = African Brown
NT-M = Natural
SNT-M = Super Natural |
| Material | Rubber Wood
(<i>Hevea brasiliensis</i> Muell.-Arg.) | Finish | Matt |
| Features | True Skin Calf Heads
Traditional rope tuning system | | |

HEADLINER® SERIES WOOD DJEMBES

If you are looking for an affordable djembe for drum circles or spontaneous jam sessions, don't look any further! The MEINL Headliner® Series Djembes have it all! Equipped with hand selected goat heads they produce the classic djembe sounds reaching from fat basses to rich open tones and cutting slaps.



All djembes are now equipped with six tuning lugs for better tuning consistency

Black powder coated 2 mm rounded rim



HDJ600WR

HDJ600VSB

HDJ600MA

HDJ600NT

Original MEINL style tuning bracket



Rubber ringed bottom for more stability and protection

- | | | | |
|-----------------|--|-----------------|---|
| Size | 12"
23 1/2" tall | Includes | Tuning key |
| Material | Rubber Wood
(<i>Hevea brasiliensis</i> Muell.-Arg.) | Colours | MA = Maple
NT = Natural
VSB = Vintage Sunburst
WR = Wine Red |
| Features | 8 mm strong tuning lugs
2 mm rounded rims
Original MEINL style tuning brackets
Black powder coated hardware
Hand selected goat heads | | |
| | | Finish | Hi Gloss |



ORIGINAL AFRICAN STYLE ROPE TUNED WOOD DJEMBES

The MEINL Original African Style Rope Tuned Wood Djembes are carved from one solid piece of plantation grown Mahogany Wood. These high quality instruments are crafted with great attention to detail and provide an outstanding and voluminous sound. The complex rope tuning system guarantees an ideal and long lasting tuning of the instrument. The MEINL Original African Style Rope Tuned Wood Djembes come bundled with the Professional Djembe Bags.

NEW

BAG INCLUDED!

Hand selected goat head

Pre-stretched high quality HTP nylon rope



ADJ2-L+BAG bundle with MDJB-M

ADJ2-XL+BAG bundle with MDJB-M



Hand carved ornament

Carved from one solid piece of plantation grown Mahogany Wood



ADJ2-M+BAG bundle with MDJB-S

- Material** Mahogany Wood
- Features** Carved from one solid piece of plantation grown Mahogany Wood
Hand selected goat heads
Double braided HTP nylon ropes
Hand carved shells
- Includes** Professional Djembe Bag made out of heavy duty padded nylon

Sizes	Diameter	Tall
M	9 1/4" – 10 1/4"	20"
L	10 3/4" – 12 1/4"	24"
XL	12 3/4" – 14 1/4"	25"

HTP rope	Thickness	Runners
M	4 mm	25
L	4 mm	35
XL	5 mm	35



KES-01

KESSING

The Kessing is a traditional djembe accessory that provides a dry rattling accompaniment to the drum. It slides securely into the webbing and is removable.

NEW



Example with three kessings

- Size** Medium
- Material** Aluminum



STEELY II DJEMBE STAND (patented)

The Steely II Djembe stand (patented) features all of the same designs as the Steely II Conga stands (patented). It can be adjusted to accommodate various djembe sizes using three spacers and is fully height adjustable. Perfect for drum circles and other street percussion activities.

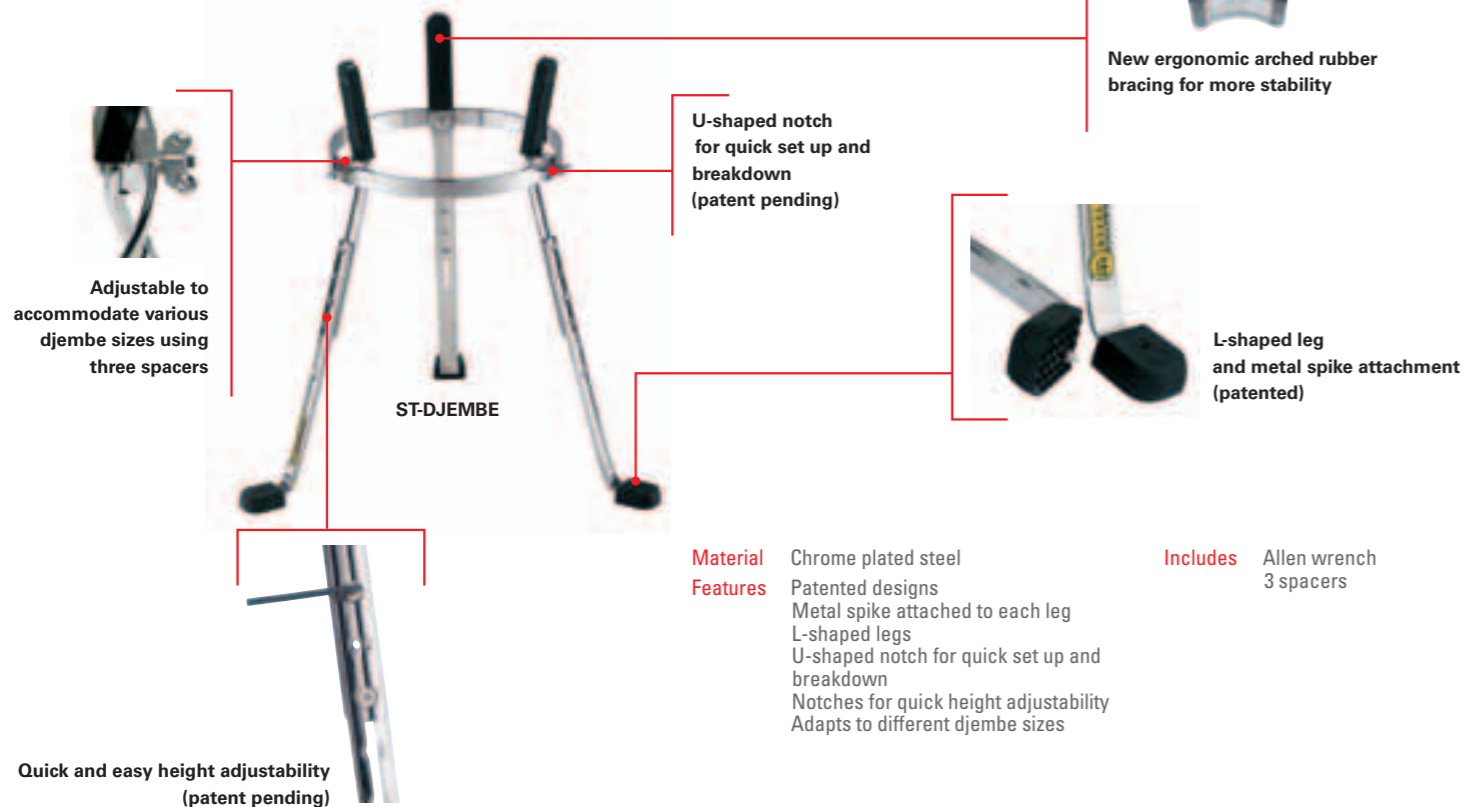

PROFESSIONAL DJEMBE STAND

The MEINL Djembe Stand was designed to firmly hold any djembe in the traditional playing position. A resistant nylon strap is placed around the drum and two rubber padded u-shaped hooks are slide into the bottom of the shell. It can be angled and is fully height adjustable.

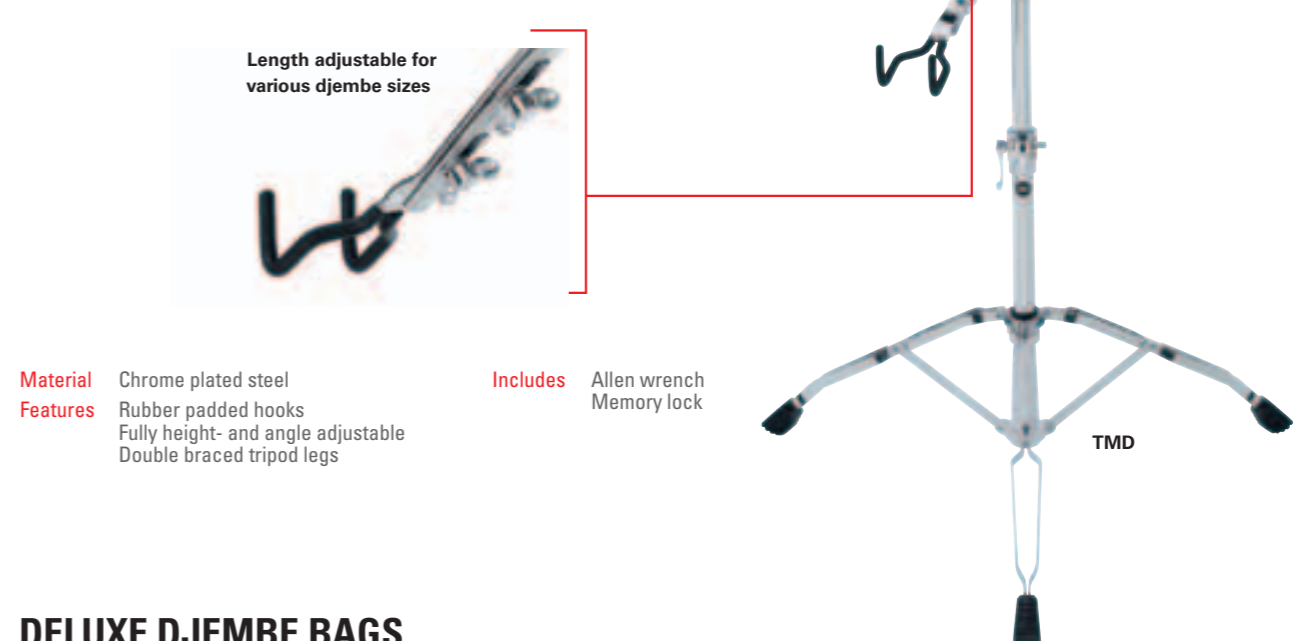

PROFESSIONAL DJEMBE BAGS

The MEINL Djembe Bags come in two sizes medium and large to fit all common djembe models. Additional features are padded backpack straps and an external pocket for accessories.



DELUXE DJEMBE BAGS

The MEINL Deluxe Djembe Bags feature an additional layer of synthetic fur, which removes surface moisture and provides additional protection. They come in medium and large sizes enabling them to fit all common djembe models. Additional features are padded backpack straps and an external pocket for accessories.



DJEMBES

Model No.	Size	Height	Material	Features	SPARE PARTS					Page
					Head	Rim	Lug	Bracket		
FLOATUNE SERIES 12 3/4" WOOD DJEMBES										
DJW2	12 3/4"	25 1/4"	•	• • • • •	TS-G-02	SSR-30	LUG-04			32
FLOATUNE SERIES 12" WOOD DJEMBES										
DJW3	12"	24 1/4"	•	• • • • •	TS-G-01	SSR-29	LUG-04			33/34
ROPE TUNED WOOD DJEMBES										
DJWR3	12"	24 1/4"	•	• • • • •	TS-CA-01					36
FLOATUNE SERIES FIBERGLASS DJEMBES										
DJF3	12"	24 1/4"	•	• • • • •	TS-G-01	SSR-29	LUG-05			34
HEADLINER® SERIES WOOD DJEMBES										
HDJ600	12"	23 1/2"	•		HHEAD12W	HRIM12W	HDLUGW	HDBRACKET-02		37
ORIGINAL AFRICAN STYLE ROPE TUNED WOOD DJEMBES										
ADJ2-M+BAG	9 1/4"-10 1/4"	20"	•	• • • • •	HEAD-53					39
ADJ2-L+BAG	10 3/4"-12 1/4"	24"	•	• • • • •	HEAD-54					38
ADJ2-XL+BAG	12 3/4"-14 1/4"	25"	•	• • • • •	HEAD-55					38
SPARE PARTS FOR STANDS										
Fast Lock Set, chrome					STAND-14					41
Rubber Feet (set of 3 pcs.) for Djembe Stand					STAND-16					41
Rubber Feet (set of 3 pcs.) for Steely-II Stand					STAND-35					40
Rubber Tops (set of 3 pcs.) for Steely-II Stand					STAND-21					40
Socket Screw (set of 2 pcs.) chrome					STAND-27					40
OTHER PARTS										
Lug Oil					SPARE-09					
Tuning Key, 13mm + 14mm, L-shaped, chrome					KEY-02					

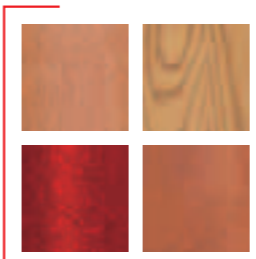

DIVERSITY IN MATERIALS

MEINL uses four different materials to produce premium djembes: Rubber Wood (*Hevea brasiliensis* Muell.-Arg.), American White Ash (*Fraxinus americana* L.), premium fiberglass, and plantation grown Mahogany Wood. This diversity covers all djembe sounds ever required in any musical setting.

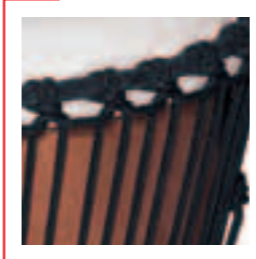

ROPE TUNING SYSTEM

The complex rope tuning system guarantees an ideal and long lasting tuning of the instrument, with the HTP nylon rope that is used being of the highest standard.



PATENTED FLOATUNE TUNING SYSTEM

The patented MEINL Floatune Tuning System makes drilling holes into the shell unnecessary while enhancing the resonance of the drum increase its projection.



TRUE SKIN GOAT HEADS

The original MEINL True Skin Goat Heads on djembes offer the widest dynamic range from cutting slaps to powerful bass tones. True Skin hides are selected by specialists. After the selection process, each skin is gently tanned using a special MEINL procedure and then mounted by hand to become a first class True Skin Head.



TRUE SKIN CALF HEADS

The original MEINL True Skin Calf Heads on the MEINL Rope Tuned Djembes offer an alternative sound with fewer overtones and a warmer overall spectrum. True Skin hides are selected by specialists. After the selection process, each skin is gently tanned using a special MEINL procedure and then mounted by hand to become a first class True Skin Head.





BONGOS

MIPA AWARD FOR MEINL FREE RIDE SERIES COLLECTION WOOD BONGOS

The "Musikmesse International Press Award" is annually presented by 55 music magazines from all over the world that get together and vote for the best products in certain categories.

The MEINL Free Ride Series Collection Series Bongos won the MIPA Award in the "Best Percussion Product" category.



FREE RIDE SUSPENSION SYSTEM (patented)

This original MEINL innovation allows for the first time ever, freely resonating bongo shells.



The Macho and Hembra are no longer attached to each other by a wooden block mounted between the shells spoiling the resonance of the instrument

With the patented MEINL Free Ride Suspension System the two drums are firmly attached utilizing the bottom rims which results in not having to drill into the bongo shells

PASSION FOR DETAILS

FREE RIDE SERIES (patented) COLLECTION WOOD BONGOS

MEINL Collection Series Wood Bongos are the finest bongos available today. They are made entirely by hand and exhibit unparalleled sound, charm, and workmanship. MEINL's expertise in wood selection enabled to study the sonic properties of a large variety of exclusive woods. These extensive studies now reflect in the excellence of these collectors item bongos. The patented MEINL Free Ride System allows freely resonating bongo shells.



Sizes 7" Macho & 8 1/2" Hembra
Materials AWA-M = American White Ash (*Fraxinus americana* L.)
 ROW-M = Rose Wood (*Pterocarpus macrocarpus* Kurz)
 TW-M = Teak Wood (*Tectona grandis* L.f.)

Features MEINL Free Ride Suspension System (patented)
 Chrome plated hardware
 True Skin Cow Heads
 8 mm strong tuning lugs
 3 mm rounded SSR-Rims
 Resonance Shaping Area
Includes Accessory pouch
 L-shaped tuning key
 Tune Up Oil
Finish Matt

FREE RIDE SERIES (patented) WOODCRAFT BONGO

The MEINL Woodcraft Bongo, just as the Woodcraft Congas, stands for tradition combined with exceptional workmanship. Only the finest hand selected materials are used to produce this premium bongo which produces the authentic and typical loud slapping bongo sound. The patented MEINL Free Ride System allows freely resonating bongo shells.



Sizes 7" Macho & 9" Hembra
Material American White Ash (*Fraxinus americana* L.)
Features MEINL Free Ride Suspension System (patented)
 Chrome plated hardware
 True Skin Cow Heads
 8 mm strong tuning lugs
 4 mm traditional TTR-Rims
 Resonance Shaping Area
Includes Accessory pouch
 L-shaped tuning key
 Tune Up Oil
Colour ZFA-M = Zebra Finished Ash
Finish Matt

FREE RIDE SERIES (patented) FWB400 WOOD BONGOS

The MEINL FWB400 Free Ride Series Wood Bongos are the preferred bongo model by many top percussionists. Exceptional sound qualities combined with a wide variety of colours make it the perfect bongo for the working musician. The patented MEINL Free Ride System allows freely resonating bongo shells.



Sizes 7" Macho & 8 1/2" Hembra
Material Rubber Wood (*Hevea brasiliensis* Muell.-Arg.)
Features MEINL Free Ride Suspension System (patented)
 Chrome plated hardware
 True Skin Cow Heads
 8 mm strong tuning lugs
 3 mm rounded SSR-Rims
 Resonance Shaping Area

Includes Accessory pouch
 L-shaped tuning key
 Tune Up Oil
Colours ARF = Aztec Red Fade
 CR = Cherry Red
 EBK = Ebony Black
 GAB = Gold Amber Sunburst
 NT = Natural
Finish Hi Gloss



FREE RIDE SERIES (patented) FFB400 FIBERGLASS BONGOS

The MEINL FFB400 Free Ride Series Fiberglass Bongos have a stunning sound reaching from powerful mids to sharp highs. Due to their fiberglass shells they are extremely durable and the perfect instrument for the working musician on the road.



Sizes 7" Macho & 8 1/2" Hembra
Material Premium fiberglass
Features MEINL Free Ride Suspension System (patented)
 Chrome plated hardware
 True Skin Cow Heads
 8 mm strong tuning lugs
 3 mm rounded SSR-Rims
 Resonance Shaping Area

Includes Accessory pouch
 L-shaped tuning key
 Tune Up Oil
Colours BKSP = Black Sparkle
 BSP = Blue Sparkle
 STS = Sterling Silver

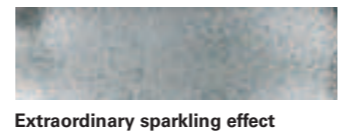

Extraordinary sparkling effect

FREE RIDE SERIES (patented) FWB300 WOOD BONGO

The MEINL FWB300 Free Ride Series Wood Bongo is equipped with traditional rims and the finest, hand selected cow heads. It produces a warm, yet full and voluminous sound. The patented MEINL Free Ride System allows the bongo shells to resonate freely.



Sizes 6 3/4" Macho & 8" Hembra
Material Rubber Wood (*Hevea brasiliensis* Muell.-Arg.)
Features MEINL Free Ride Suspension System (patented)
 Chrome plated hardware
 True Skin Cow Heads
 8 mm strong tuning lugs
 4 mm traditional TTR-Rims

Includes Accessory pouch
 L-shaped tuning key
 Tune Up Oil
Colour NT-M = Natural
Finish Matt

WB300 WOOD BONGO

Representing the traditional style, the MEINL WB300 Wood Bongo is equipped with a solid woodblock that attaches the two drums together. This enables a sturdy and comfortable way of playing the bongo traditionally between the legs. It features traditional rims and the finest hand selected cow heads, producing a warm, full and voluminous sound.



Sizes 6 3/4" Macho & 8" Hembra
Material Rubber Wood (*Hevea brasiliensis* Muell.-Arg.)
Features Solid woodblock connection
 Chrome plated hardware
 True Skin Cow Heads
 8 mm strong tuning lugs
 4 mm traditional TTR-Rims

Includes Accessory pouch
 L-shaped tuning key
 Tune Up Oil
Colour SNT-M = Super Natural
Finish Matt

PROFESSIONAL BONGO BAG

The MEINL Bongo Bag fits all common bongo models and still has enough room for some hand percussion instruments. A padded separator is included.

Material Heavy duty padded nylon
Features Additional room for accessories
 Padded shoulder strap
 Carrying grip
 Padded separator



MBB



Roland Peil, Germany (Fanta 4)

FREE RIDE SERIES (patented) FWB200 WOOD BONGOS

The MEINL FWB200 Free Ride Series Wood Bongos are made from high quality components and produce a superb tone. The patented MEINL Free Ride System allows freely resonating bongo shells.



- Sizes** 6 3/4" Macho & 8" Hembra
Material Rubber Wood
(Hevea brasiliensis Muell.-Arg.)
Features MEINL Free Ride Suspension System (patented)
 Chrome plated hardware
 Hand selected buffalo heads
 8 mm strong tuning lugs
 2.5 mm rounded SSR-Rims

- Includes** Accessory pouch
 L-shaped tuning key
 Tune Up Oil
Colours ARF = Aztec Red Fade
 GAB = Gold Amber Sunburst
 NT = Natural
Finish Hi Gloss

FWB200NT

FWB200GAB

FWB200ARF

FREE RIDE SERIES (patented) FFB200 FIBERGLASS BONGOS

The MEINL FFB200 Fiberglass Bongos produce a compact sound with a nice spectrum of overtones. They are made from the finest components and are outstanding in quality and workmanship. Ideal for the ambitious beginner who looks for a semi-professional bongo at an affordable price.



- Sizes** 6 3/4" Macho & 8" Hembra
Material Premium fiberglass
Features MEINL Free Ride Suspension System (patented)
 Chrome plated hardware
 Hand selected buffalo heads
 8 mm strong tuning lugs
 2.5 mm rounded SSR-Rims

- Includes** Accessory pouch
 L-shaped tuning key
 Tune Up Oil
Colours BKSP = Black Sparkle
 BSP = Blue Sparkle
 STS = Sterling Silver

FFB200STS

FFB200BKSP

FFB200BSP

Extraordinary sparkling effect

FREE RIDE SERIES (patented) FWB190 WOOD BONGOS

The MEINL FWB190 Free Ride Series Wood Bongos are perfect for the ambitious beginner and for those who look for an affordable second set. Its professional features are outstanding in this price range. The patented MEINL Free Ride System allows freely resonating bongo shells.



- Sizes** 6 3/4" Macho & 8" Hembra
Material Rubber Wood
(Hevea brasiliensis Muell.-Arg.)
Features MEINL Free Ride Suspension System (patented)
 Black powder coated hardware
 Hand selected buffalo heads
 8 mm strong tuning lugs
 2.5 mm rounded SSR-Rims

- Includes** Accessory pouch
 L-shaped tuning key
 Tune Up Oil
Colours CB = Coffee Burst, hi gloss
 CR-M = Cherry Red, matt
 SNT-M = Super Natural, matt
 TSR-M = Tequilla Sunrise, matt

FWB190CR-M

FWB190TSR-M

FWB190SNT-M

FWB190CB

FREE RIDE SERIES (patented) MINI WOOD BONGOS

The MEINL Mini Wood Bongo is a smaller version of a real sized bongo. It is equipped with professional features in miniature size just like the regular size standard model.



- Sizes** 3 1/2" Macho & 4 1/4" Hembra
Material Rubber Wood
(Hevea brasiliensis Muell.-Arg.)
Features Free Ride Suspension System (patented)
 True Skin Buffalo Heads
 Rounded SSR-Rims
 Chrome plated hardware

- Includes** Tuning key
Colours SNT-M = Super Natural
 TSR-M = Tequilla Sunrise
Finish Matt

FWB100TSR-M

FWB100SNT-M

Chrome plated rounded SSR-Rim

HEADLINER® SERIES WOOD BONGOS

MEINL Headliner® Series Bongos are perfect for the student or hobbyist who is looking for a high quality instrument right from the beginning.



Sizes 6 3/4" Macho & 8" Hembra
Material Rubber Wood
(Hevea brasiliensis Muell.-Arg.)
Features Hand selected buffalo heads
 8 mm strong tuning lugs
 2 mm rounded rims
 Black powder coated hardware
 Interior backing plates

Includes Tuning key
Colours MA = Maple
 NT = Natural
 VSB = Vintage Sunburst
 WR = Wine Red
Finish Hi Gloss

BONGO BAG

The MEINL standard Bongo Bag offers dependable protection at an affordable price making transportation as hassle free as possible.



Size Bongos up to 7 1/2" Macho & 8 1/2" Hembra
Material Heavy duty padded nylon
Features Padded shoulder strap
 Carrying grip

PROFESSIONAL BONGO STAND (patented)

The patented MEINL Bongo Stand features a new design concept and simple functionality. The bongo is placed on a padded T-shaped tube and secured with a convenient knob screw. A stable metal clamp holds the entire unit securely in place.

Material Chrome plated steel
Features Patented design
 Padded T-shaped tube
 Fully height- and angle adjustable
 Double braced tripod legs
 Fits all common bongos
Includes Allen wrench
 Memory locks

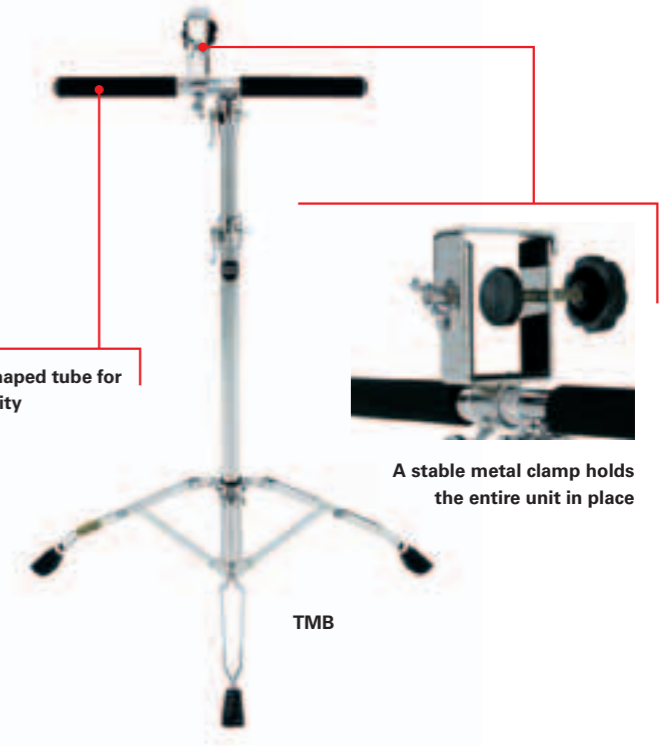

PROFESSIONAL BONGO STAND (patented) FOR SEATED PLAYERS

This version of MEINL's Professional Bongo Stand (patented) has all the features of its regular model, however it can be placed low enough to be comfortably played sitting down in the traditional position. A great stand for drummers as well who incorporate a bongo into their regular drum set up.

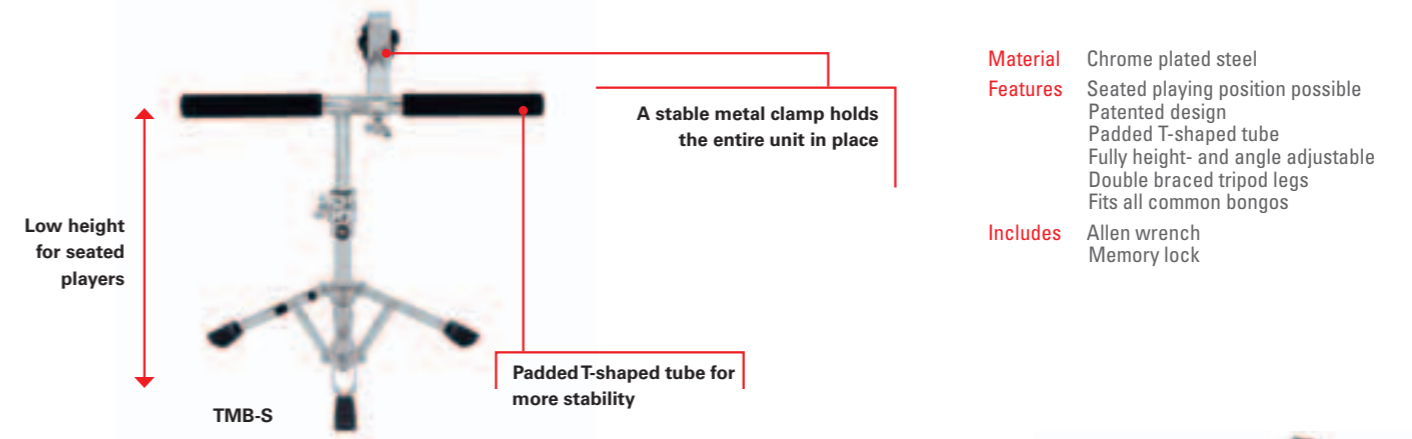

Material Chrome plated steel
Features Seated playing position possible
 Patented design
 Padded T-shaped tube
 Fully height- and angle adjustable
 Double braced tripod legs
 Fits all common bongos
Includes Allen wrench
 Memory lock

BONGO STAND (patent pending)

The MEINL Headliner® Series Bongo Stand (patent pending) combines easy handling and functionality with reliability and sturdy construction. A newly designed bracket enables extremely quick and easy mounting, yet holds the entire bongo securely in place.

Material Chrome plated steel
Features Quick set up
 Easy handling
 Reliable placement
 Double braced tripod stand
 Fits all common bongos
Includes Wrench

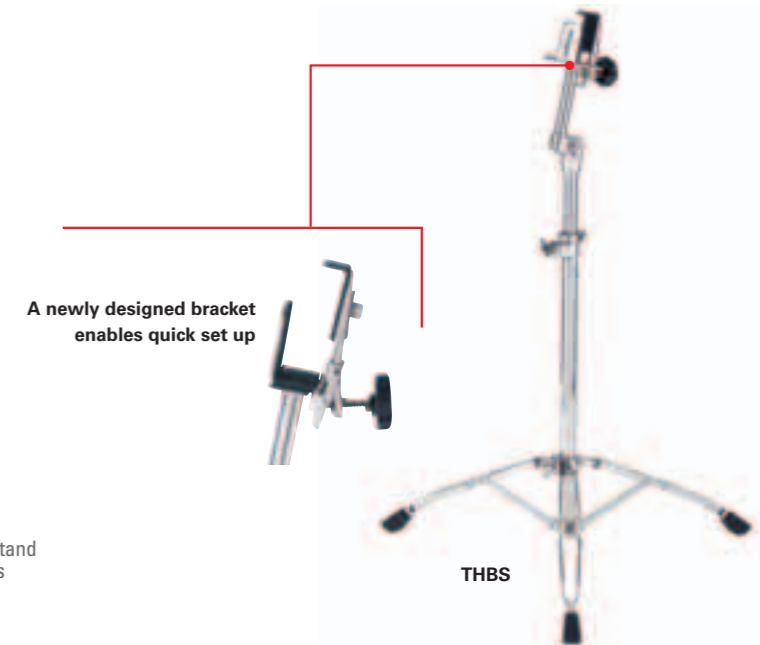

BONGOS

Model No.	Size	Material	Features	SPARE PARTS			Page
				Head	Rim	Lug	
FREE RIDE SERIES COLLECTION WOOD BONGOS							
CS400	7"	• • • • •	• • • • •	TS-C-02	SSR-02	LUG-07	48
CS400	8 1/2"	• • • • •	• • • • •	TS-C-03	SSR-04	LUG-07	48
FREE RIDE SERIES WOODCRAFT BONGO							
WB500	7"	• • • • •	• • • • •	TS-C-11	TTR-26	LUG-07	48
WB500	9"	• • • • •	• • • • •	TS-C-12	TTR-27	LUG-07	48
FREE RIDE SERIES FWB400 WOOD BONGOS							
FWB400	7"	• • • • •	• • • • •	TS-C-02	SSR-02	LUG-07	49
FWB400	8 1/2"	• • • • •	• • • • •	TS-C-03	SSR-04	LUG-07	49
FREE RIDE SERIES FFB400 FIBERGLASS BONGOS							
FFB400	7"	• • • • •	• • • • •	TS-C-02	SSR-02	LUG-07	50
FFB400	8 1/2"	• • • • •	• • • • •	TS-C-03	SSR-04	LUG-07	50
FREE RIDE SERIES FWB300 WOOD BONGO							
FWB300	6 3/4"	• • • • •	• • • • •	TS-C-13	TTR-31	LUG-22	51
FWB300	8"	• • • • •	• • • • •	TS-C-14	TTR-32	LUG-22	51
WB300 WOOD BONGO							
WB300	6 3/4"	• • • • •	• • • • •	TS-C-13	TTR-31	LUG-22	51
WB300	8"	• • • • •	• • • • •	TS-C-14	TTR-32	LUG-22	51
FREE RIDE SERIES FWB200 WOOD BONGOS							
FWB200	6 3/4"	• • • • •	• • • • •	HEAD-38	SSR-20	LUG-22	52
FWB200	8"	• • • • •	• • • • •	HEAD-39	SSR-21	LUG-22	52
FREE RIDE SERIES FFB200 FIBERGLASS BONGOS							
FFB200	6 3/4"	• • • • •	• • • • •	TS-B-50	SSR-34	LUG-23	52
FFB200	8"	• • • • •	• • • • •	TS-B-51	SSR-35	LUG-23	52
FREE RIDE SERIES FWB190 WOOD BONGOS							
FWB190	6 3/4"	• • • • •	• • • • •	HEAD-38	SSR-18	LUG-22	53
FWB190	8"	• • • • •	• • • • •	HEAD-39	SSR-19	LUG-22	53
FREE RIDE SERIES MINI WOOD BONGOS							
FWB100	3 1/2"	• • • • •	• • • • •	TS-B-31	SSR-16	LUG-19	53
FWB100	4 1/4"	• • • • •	• • • • •	TS-B-32	SSR-17	LUG-19	53
HEADLINER® SERIES WOOD BONGOS							
HB100	6 3/4"	• • • • •	• • • • •	HHEAD634W	HRIM634W	HBLUG	54
HB100	8"	• • • • •	• • • • •	HHEAD8W	HRIM8W	HBLUG	54

SPARE PARTS FOR STANDS		
Memory Clamp, chrome, for middle stand tube for TMB + TMB-S	STAND-07	55
Memory Clamp, chrome, for lower stand tube for TMB + TMB-S	STAND-09	55
Memory Clamp, chrome, for upper stand tube for TMB	STAND-11	55
Fast Lock Set, chrome for TMB + TMB-S	STAND-14	55
Rubber Feet (set of 3 pcs.) for all Bongo Stands	STAND-16	55
L-Shaped Clamp for top part for TMB + TMB-S	STAND-18	55
Upper Stand Section, complete for TMB	STAND-34	55

OTHER PARTS	
Lug Oil	SPARE-09
Tuning Key, 13mm + 14mm, L-shaped, chrome	KEY-02



FREE RIDE SUSPENSION SYSTEM (patented)

The Macho and Hembra are no longer attached to each other by a wooden block mounted between the shells spoiling the resonance of the instrument. Whereas with the patented MEINL Free Ride Suspension System the two drums are firmly attached utilizing the bottom rims which results in not having to drill into the bongo shells. It allows for the first time ever, freely resonating bongo shells.



RESONANCE SHAPING AREA

The MEINL Resonance Shaping Area is a fine solution to enhance the resonance of the bongos. The center part of the two bongo shells are crafted thinner than usual while still maintaining its full stability. The result is a superior timbre and better resonance of the instrument.

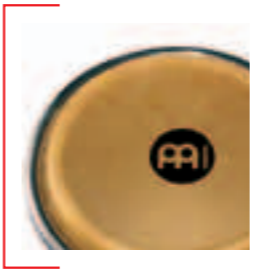

TRUE SKIN COW HEADS

The original MEINL True Skin Cow Heads are perfect sounding hides for bongos and meet all requirements demanded by professional players. They have outstanding sound qualities, are easy to tune, resistant, and have a smooth surface for comfortable playing. True Skin hides are selected by specialists. After the selection process, each skin is gently tanned using a special MEINL procedure and then mounted by hand to become a first class True Skin Head.

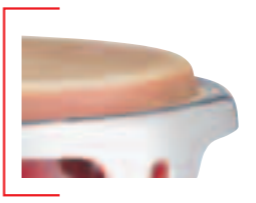

SSR

The MEINL Safe & Sound-Rim (SSR) for bongos features a rounded profile to support a comfortable playing feel and to assist in the prevention of palm injuries.



TTR

The MEINL Traditional-Tuning-Rim (TTR) for bongos represents the traditional "Cuban Style." They are narrowly placed around the shell and enhances the overall bongo sound.





CAJONS

MIPA AWARD FOR MEINL CONGA CAJON

The "Musikmesse International Press Award" is annually presented by 55 music magazines from all over the world that get together and vote for the best products in certain categories.

The MEINL Conga Cajon won the MIPA Award in the "Best Percussion Product" category.



PICKUP CAJONS

NEW

The MEINL Pickup Cajons are equipped with the DST pickup microphone and the A1.2 preamp system with volume control from B-Band®. This active system includes a specially designed preamp, high quality endpin output jack and a durable battery. The structure is light in mass adding very little weight to the instrument. The sound reproduction is amazingly pure and clear. This installed microphone system provides comfortable and easy handling in live situations. Plug in and play.

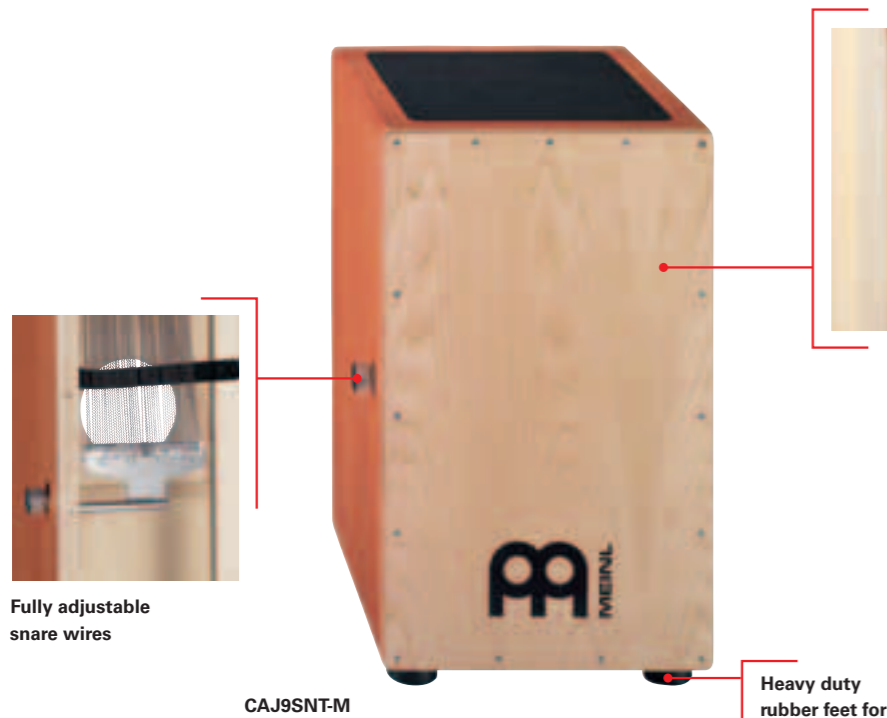

DST pickup microphone from
B-BAND
ELECTRIST INSTRUMENTS

- Materials** Frontplate: American White Ash (*Fraxinus americana* L.)
Resonating body: Rubber Wood (*Hevea brasiliensis* Muell.-Arg.)
- Features** DST pickup microphone
Active A1.2 preamp system with volume control from B-Band®
Adjustable top corners
Internal, adjustable snare wires
Padded sitting surface
Wide sound options
- Includes** 9-volt battery
- Finish** Matt



- Materials** Frontplate: Makah-Burl
Resonating body: Rubber Wood (*Hevea brasiliensis* Muell.-Arg.)
- Features** DST pickup microphone
Active A1.2 preamp system with volume control from B-Band®
Adjustable top corners
Built in sizzle effect
Padded sitting surface
Wide sound options

- Includes** 9-volt battery
Allen wrench
- Finish** Matt

BASS PEDAL CAJON (patent pending)

NEW

The MEINL Bass Pedal Cajon features another unique innovation, which proves once again MEINL's leading R/D status in the worldwide percussion scene. A pedal attached to the cajon adjusts the amount of pressure used to press the snare wires against the front plate, and can even be turned off completely. This system allows the player to change the settings of the snare wires while playing a rhythm with both hands without an interruption. Due to its size being bigger than the standard MEINL Cajons, the instrument has more projection and bass frequencies.

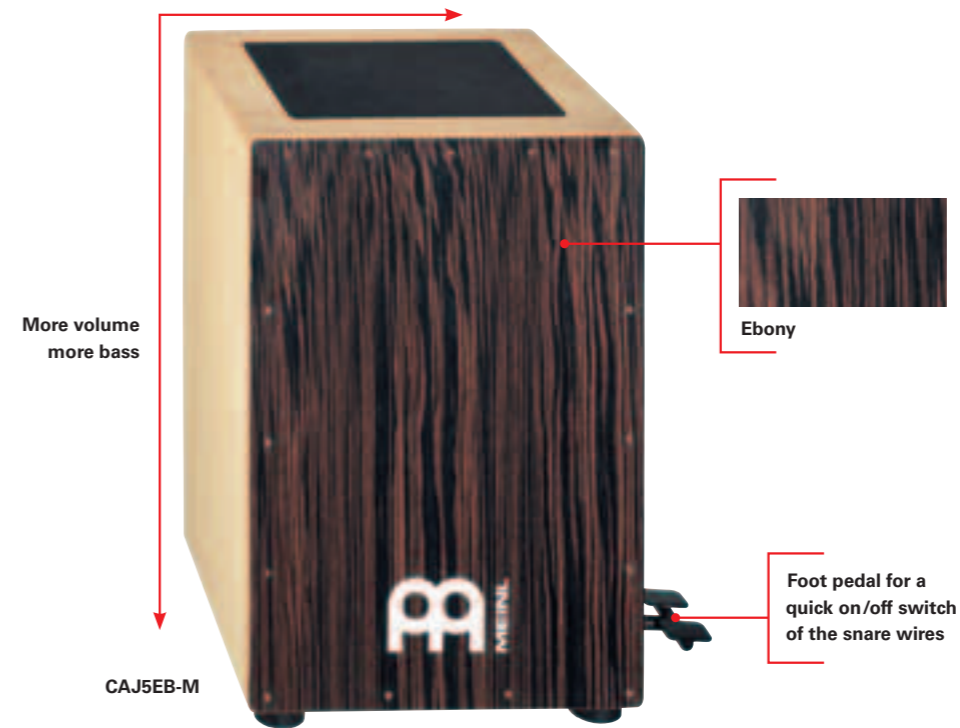

- Materials** Frontplate: Ebony
Resonating body: Rubber Wood (*Hevea brasiliensis* Muell.-Arg.)
- Features** Foot pedal
Internal, adjustable snare wires
Great bass tones
Adjustable top corners
Padded sitting surface
Wide sound options
- Finish** Matt

DELUXE BASS PEDAL CAJON BAG

NEW

The MEINL Deluxe Cajon Bag for the CAJ5 is perfectly suited for the bigger sized Bass Pedal Cajon. It features an additional layer of synthetic fur, which removes surface moisture and provides additional protection.



SNARE CAJONS

To equip a Cajon with fully adjustable snare wires is an original MEINL innovation and proves yet again MEINL's leading R/D status in the worldwide percussion scene. The snares touch the frontplate from the inside and deliver the classical cajon sound, which is requisite in Flamenco music. A knurled knob adjusts the amount of pressure used to press the snare wires against the frontplate. Rattling ranging between light and sensitive to very loud can be achieved through adjustment. The entire snare unit can even be turned off completely.



Materials CAJ2BB-M
Frontplate: OceanBlu Burl
Resonating body: Burl
CAJ2RO-M
Frontplate: Cherry
Resonating body: Red Oak

Features Adjustable top corners
Internal, adjustable snare wires
Padded sitting surface
Wide sound options
Finish Matt

DELUXE CAJON BAG

The MEINL Deluxe Cajon Bag features an additional layer of synthetic fur, which removes surface moisture and provides additional protection. Additional features are a padded shoulder strap and an external pocket for accessories.



Materials Heavy duty padded nylon
Synthetic fur
Measures 20 1/2" W x 12" H x 12" D
Features Padded shoulder strap
External pocket
Carrying grip

American White Ash
(*Fraxinus americana L.*)

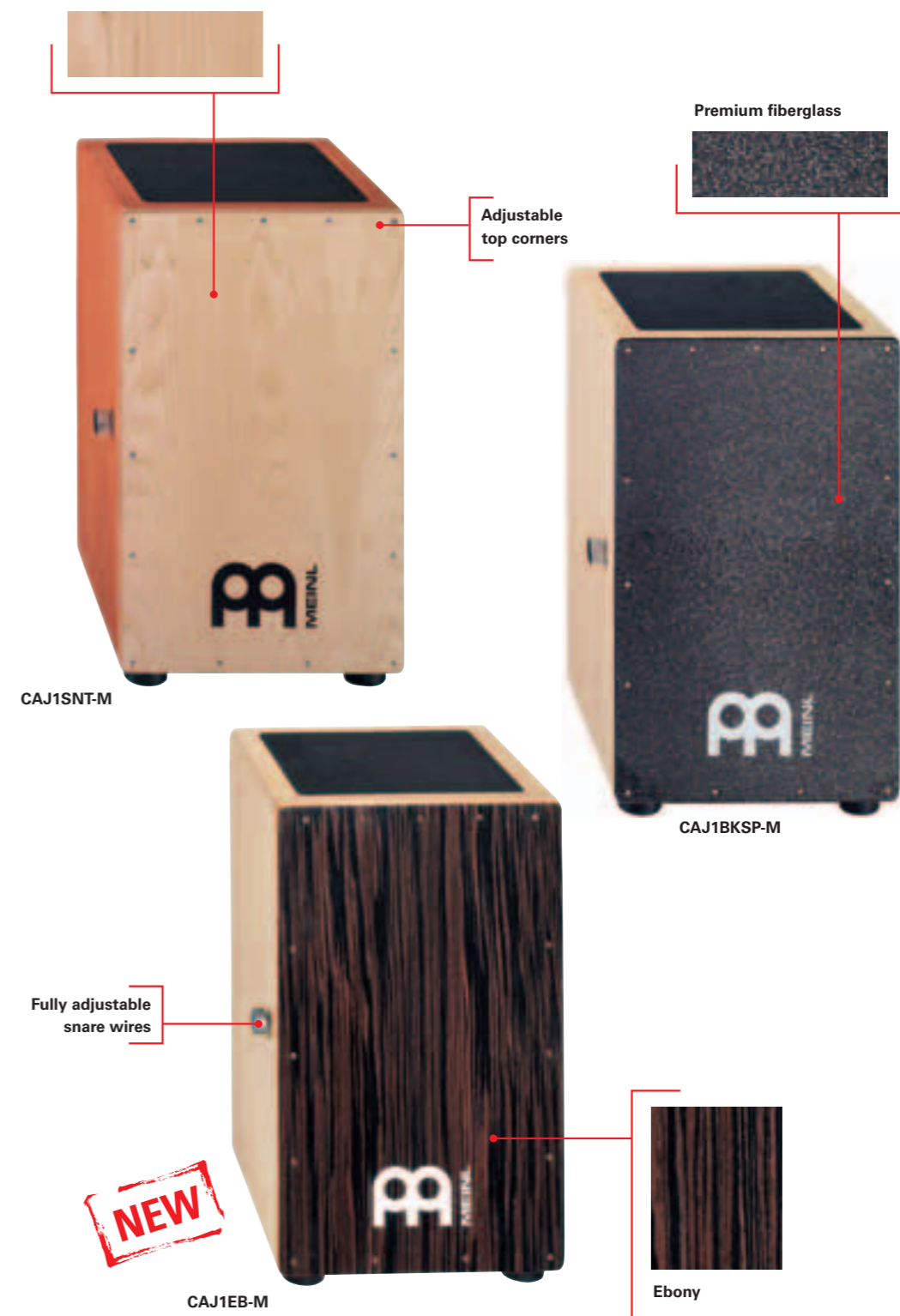

Materials CAJ1BKSP-M
Frontplate: Premium fiberglass
Resonating body: Rubber Wood
(*Hevea brasiliensis* Muell.-Arg.)
CAJ1EB-M
Frontplate: Ebony
Resonating body: Rubber Wood
(*Hevea brasiliensis* Muell.-Arg.)
CAJ1SNT-M
Frontplate: American White Ash
(*Fraxinus americana L.*)
Resonating body: Rubber Wood
(*Hevea brasiliensis* Muell.-Arg.)

Features Adjustable top corners
Internal, adjustable snare wires
Padded sitting surface
Wide sound options
Finish Matt



STRING CAJONS

MEINL Cajons feature a built in adjustable sizzle effect. Strings which touch the frontplate on the inside and span from top to bottom, deliver a sensitive rattle that can be adjusted to fit various musical applications. Featuring a frontplate made from finest Makah-Burl and Birch, this cajons are a beauties in looks and sound. A built in sizzle effect ensures the authentic rattling sound with voluminous bass tones and cutting highs.

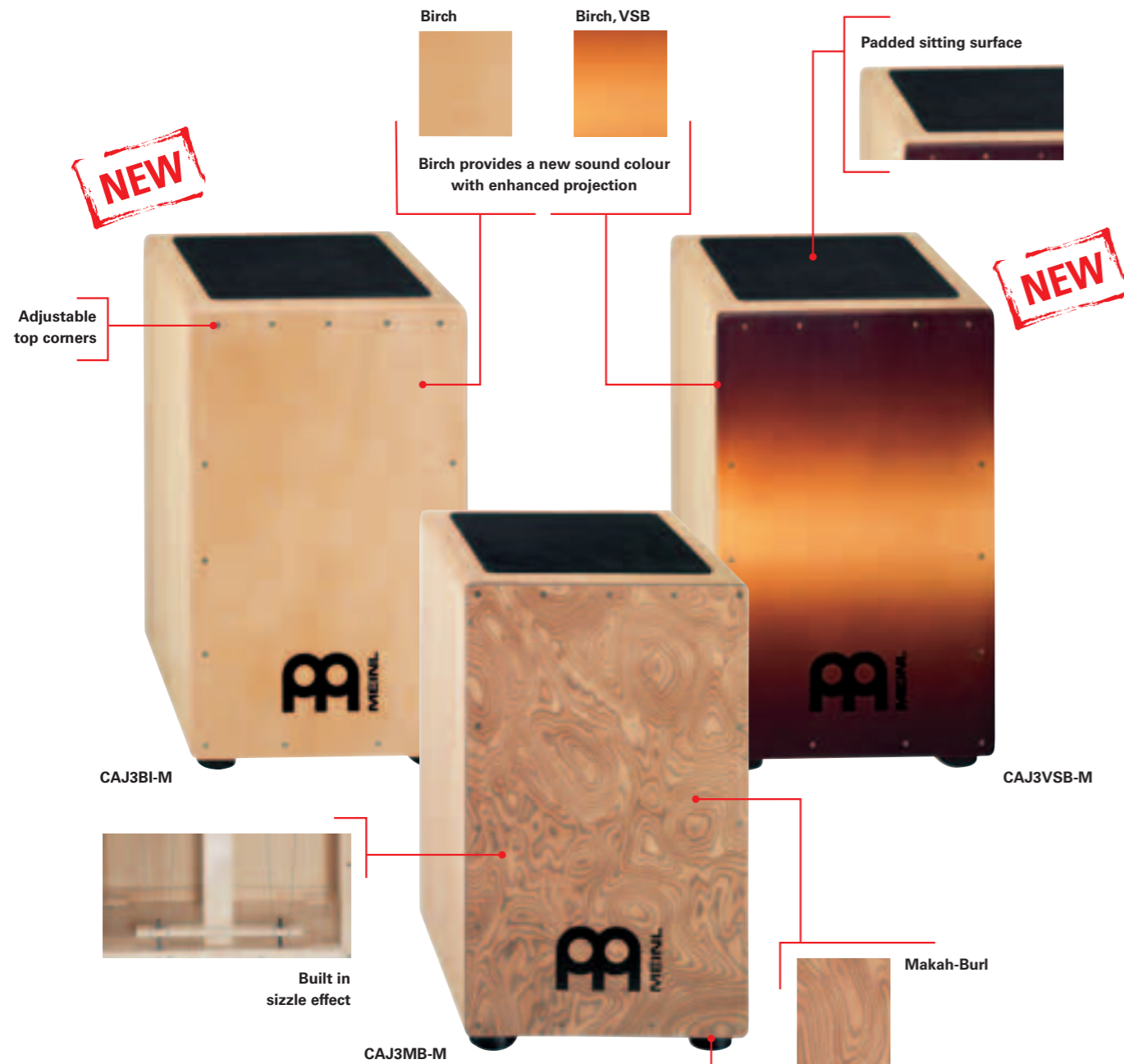

Materials CAJ3BI-M
Frontplate: Birch
Resonating body: Rubber Wood
(*Hevea brasiliensis* Muell.-Arg.)
CAJ3MB-M
Frontplate: Makah-Burl
Resonating body: Rubber Wood
(*Hevea brasiliensis* Muell.-Arg.)
CAJ3VSB-M
Frontplate: Birch
VSB = Vintage Sunburst
Resonating body: Rubber Wood
(*Hevea brasiliensis* Muell.-Arg.)

Features Adjustable top corners
Built in sizzle effect
Padded sitting surface
Wide sound options
Birch for new sound colour
Includes Allen wrench
Finish Matt

Heavy duty rubber feet for a solid base

STRING FIBERGLASS CAJON

This MEINL Cajon features a frontplate made from premium fiberglass and resonating body made from Rubber Wood, resulting in a modern look and additional sound options.

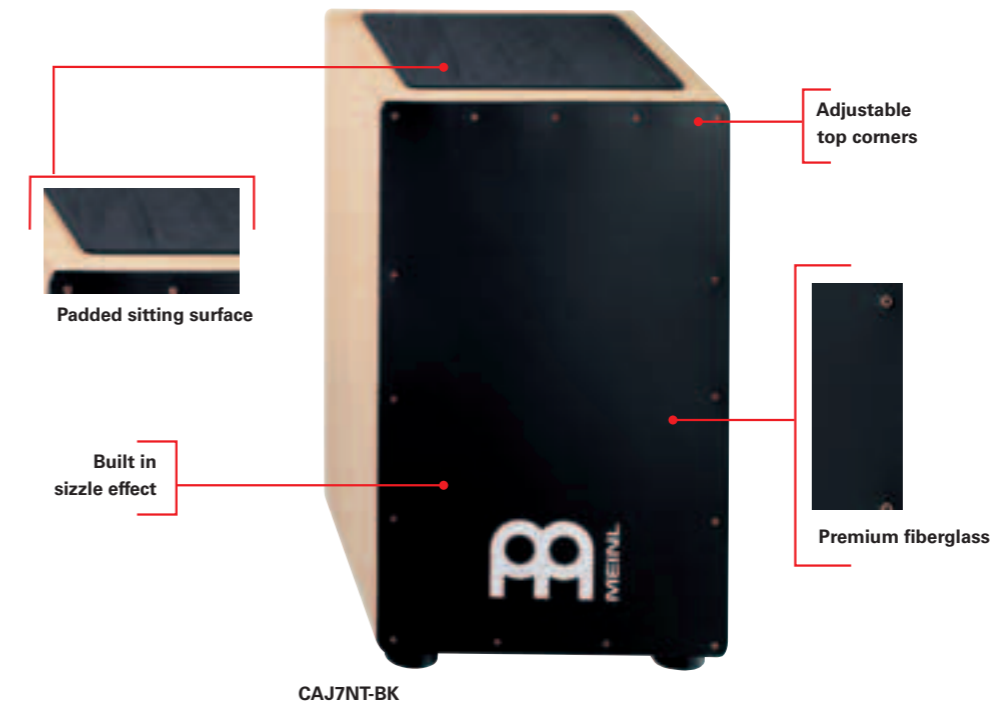

Materials Frontplate: Premium fiberglass
Resonating body: Rubber Wood
(*Hevea brasiliensis* Muell.-Arg.)

Features Adjustable top corners
Built in sizzle effect
Padded sitting surface
Wide sound options

Includes Allen wrench

PROFESSIONAL CAJON BAG

The MEINL Cajon Bag is the perfect solution for transporting these valuable and fragile instruments. Its heavy duty padded outside walls store it securely and prevents damage.



Material Heavy duty padded nylon
Measures 20 1/2" W x 12" H x 12" D
Features Padded shoulder strap
External pocket
Carrying grip

HEADLINER® SERIES CAJONS

The MEINL Headliner® Series Cajon delivers the classic cajon sound at an affordable price and can be used in Flamenco or world music. It is also very useful during unplugged gigs for delivering the rhythmic foundation for a whole band when a full drum set can't be used. For more sound options, the top corners of the cajon can be adjusted, allowing the player to customize the amount of snap desired.

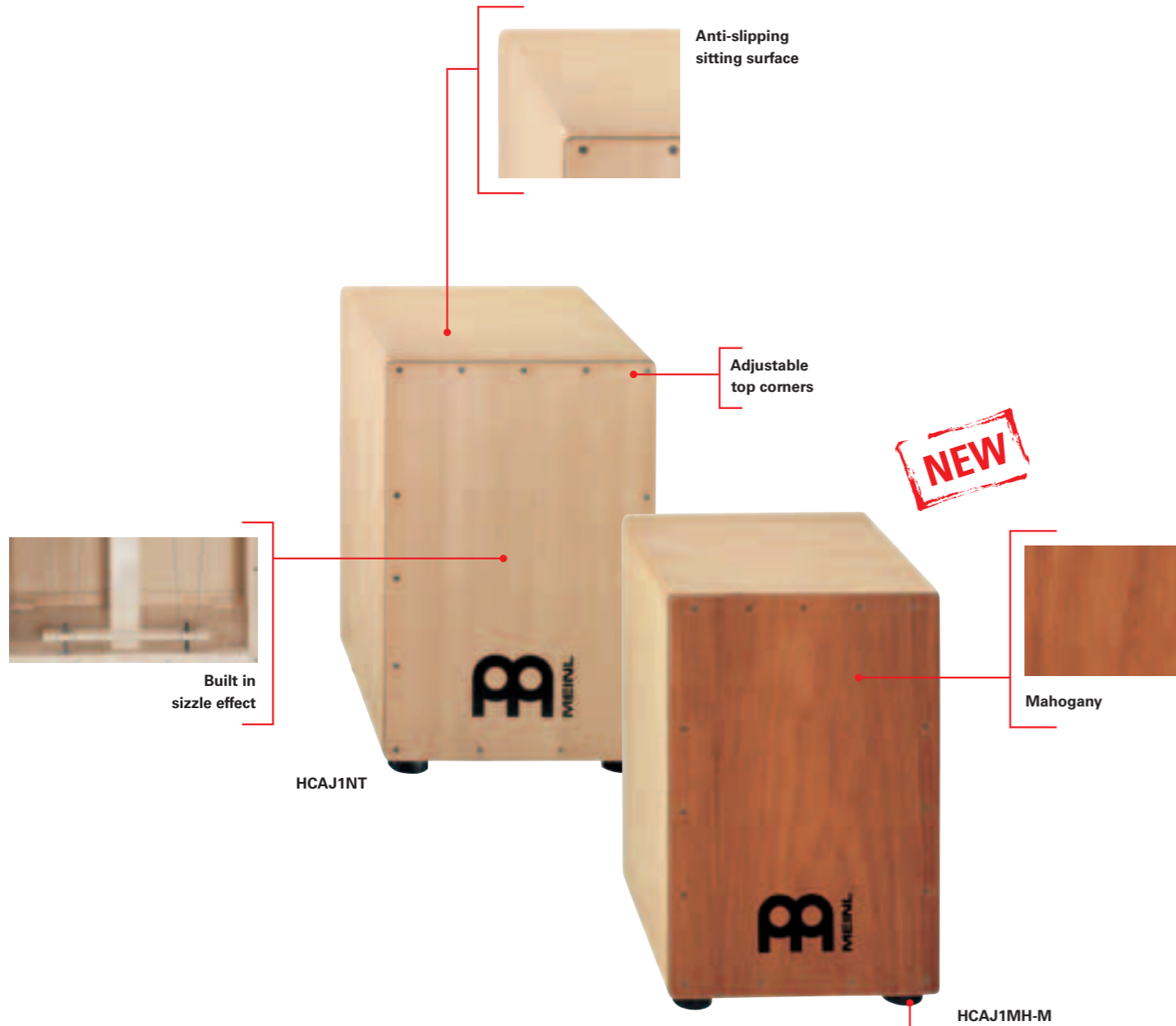

Materials HCAJ1NT
Frontplate: Rubber Wood
(*Hevea brasiliensis* Muell.-Arg.)
Resonating body: Rubber Wood
(*Hevea brasiliensis* Muell.-Arg.)
HCAJ1MH-M
Frontplate: Mahogany
Resonating body: Rubber Wood
(*Hevea brasiliensis* Muell.-Arg.)

Features Adjustable top corners
Built in sizzle effect
Anti-slipping sitting surface
Includes Allen wrench
Finish Matt

Heavy duty rubber feet for a solid base

HEADLINER® DESIGNER SERIES CAJONS

NEW

The new MEINL Headliner® Designer Series Cajons are available in three different finishes: Original Camo, Flower Power and Cork. The fabric cloth-covered body produces a drier and crisper sound compared to conventional bare wood construction. These cajons also feature a built in sizzle effect and guarantee great attention due to their eye-catching finish.



Materials Rubber Wood
(*Hevea brasiliensis* Muell.-Arg.)
Fabric cloth-covered
Features Built in sizzle effect
Adjustable top corners

Includes Allen wrench
Finish CF = Cork
FP = Flower Power
OC = Original Camo

BONGO CAJONS

The MEINL Bongo Cajon is uniquely different. It delivers the sound one can expect from a traditional cajon, and with a playing surface that has high- and low pitch sound areas, traditional bongo patterns can be played on it as well. Its compact size and light weight makes it the perfect companion on the road.

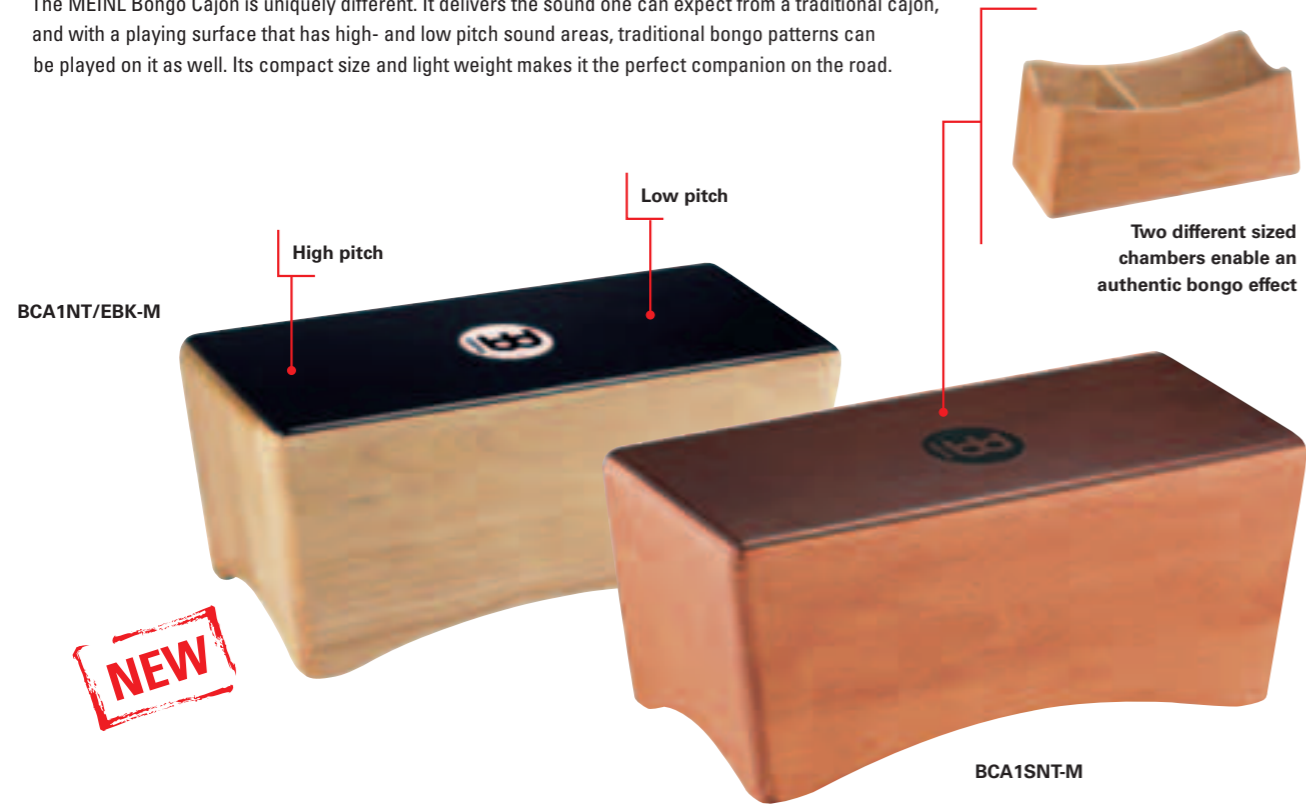

Material Rubber Wood
(*Hevea brasiliensis* Muell.-Arg.)

Colours NT/EBK-M = Natural/Ebony Black
SNT-M = Super Natural

Features High- and low pitch playing surface
Compact size and light weight

Finish Matt

PALITO

The new MEINL Palito is another addition to the comprehensive variety of our cajon instruments. Strings which touch the playing surface on the inside deliver a sensitive sizzle effect that fits to various musical applications. Its compact size and light weight makes it the perfect companion on the road.



Materials Playing surface: Makah-Burl
Resonating body: Rubber Wood
(*Hevea brasiliensis* Muell.-Arg.)

Features Built in sizzle effect
Compact size

Includes Allen wrench

Finish Matt

CONGA CAJON

The MEINL Conga Cajon is another milestone in the development of unique and innovative percussion instruments. It can be played traditionally in a trio configuration or individually as a normal cajon or as a hand-drum incorporated in a percussion set up. Integrated in a drum set configuration, it makes a great sonic addition for the drummer's means of expression. The MEINL Conga Cajon features MEINL's innovative internal and adjustable snare wire system for enhanced sound possibilities.



Materials Playing surface: Black Makah-Burl
Resonating Body: Rubber Wood
(*Hevea brasiliensis* Muell.-Arg.)

Features Internal, adjustable snare wires
Adjustable top corners

Finish Matt

CONGA CAJON STAND

The new MEINL Conga Cajon Stand has many of the same features as the Steely II Conga Stands (patented). It was designed to enable a comfortable placement of MEINL Conga Cajon when played by itself or when incorporating it into a percussion rig.



Backside

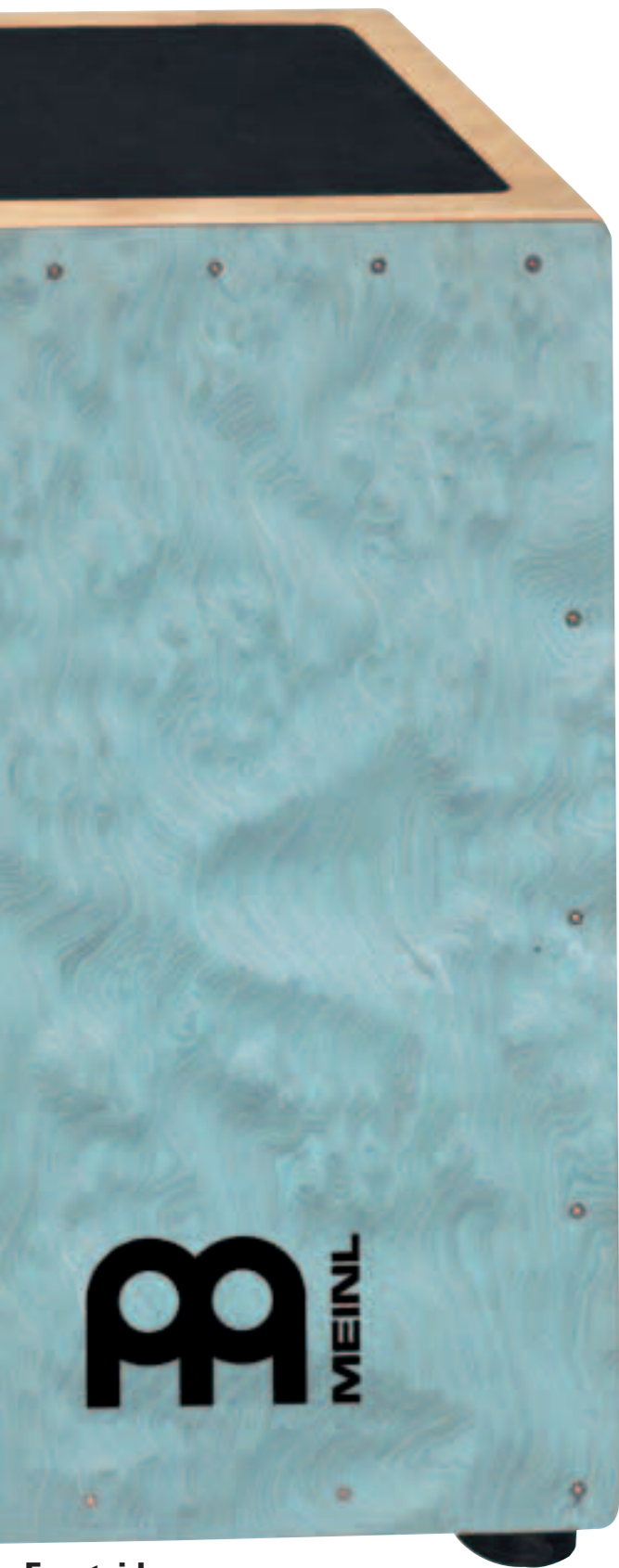

Frontside



FOOT PEDAL (patent pending)

The foot pedal features another unique innovation, which proves once again MEINL's leading R/D status in the worldwide percussion scene. A pedal attached to the cajon adjusts the amount of pressure used to press the snare wires against the front plate, and can even be turned off completely. This system allows the player to change the settings of the snare wires while playing a rhythm with both hands without an interruption.



FULLY ADJUSTABLE SNARE WIRES

To equip a Cajon with fully adjustable snare wires is an MEINL innovation and proves yet again MEINL's leading R/D status in the worldwide percussion scene. The snares touch the frontplate from the inside and deliver the classical Cajon sound, which is requisite in Flamenco music. A knurled knob adjusts the amount of pressure used to press the snares wires against the frontplate. Rattling ranging between light and sensitive to very loud can be achieved through adjustment. The entire snare unit can even be turned off completely.



BUILT IN SIZZLE EFFECT

MEINL Cajons feature a built in adjustable sizzle effect. Guitar strings which touch the frontplate on the inside and span from top to bottom, deliver a sensitive rattle that can be adjusted to fit various musical applications.



ADJUSTABLE FRONTPLATE

Being able to adjust the frontplate and therefore allowing the player to customize the amount of snap desired, is another feature that Cajons from MEINL percussion offer. This adds versatility to the sounds that can be played and ultimately allows the player to use the MEINL Cajon in a wide variety of musical settings.

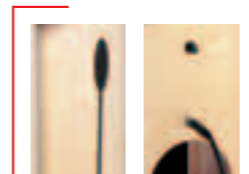

PICKUP SYSTEM

The MEINL Pickup Cajons are equipped with the DST pickup microphone and the A1.2 preamp system with volume control from B-Band®. This active system includes a specially designed preamp, high quality endpin output jack and a durable battery. The structure is light in mass adding very little weight to the instrument. The sound reproduction is amazingly pure and clear.



FIBERGLASS FRONTPLATE

MEINL is once again proving its leading position in utilizing new materials to create new sounds. Using premium fiberglass to construct the frontplate of a Cajon not only offers a drastic new look to it, but at the same time offers many new sound options which are not possible through the use of traditional materials.



TIMBALES

MIPA AWARD FOR MEINL ARTIST SERIES LUIS CONTE SIGNATURE TIMBALES

The "Musikmesse International Press Award" is annually presented by 55 music magazines from all over the world that get together and vote for the best products in certain categories.

The MEINL Artist Series Luis Conte Timbales won the MIPA Award in the "Best Percussion Product" category.



PROFESSIONAL SERIES

Robert Stein

The Roland Meinl Professional Series Timbales are made from finest German B8 cymbal bronze. They produce a fantastic warm sound with cutting rim shots and enhanced cascara playing.



Made from German B8 cymbal bronze

Applying the logo from underneath the head to prevent from wearing off (patent pending)

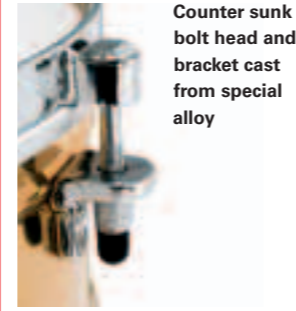

Counter sunk bolt head and bracket cast from special alloy



BT1415



Cuban style flared out bottom edge



Thoughtfully arranged lugs enable an easy way to play the Cascara

Sizes 14" & 15"
Material German B8 cymbal bronze
Features Two worked in flanges
 Cuban style flared out bottom edge
 Brackets cast from special brass alloy

Includes Adjustable cowbell holder
 Height adjustable tilting double braced tripod stand
 Accessory pouch
 L-shaped tuning key
 Tune Up Oil

ARTIST SERIES

Luis Conte

It is with the greatest appreciation and the deepest respect that we honour our friend Luis and his life's work with his MEINL Artist Series Luis Conte Signature Timbales. Perfection in even the smallest details has been achieved in this outstanding instrument. All of the specifications Luis required for his instrument have been consequently realized.



Luis Conte, USA



Counter sunk bolt head and bracket cast from special alloy



LC1BRASS

LC1STS

Extensively hammered shell

Thoughtfully arranged lugs enable an easy way to play the Cascara

Sizes 14" & 15"
Material Solid brass or stainless steel
Features Extensively hammered shells
 Two worked in flanges
 Cuban style flared out bottom edge
 Brackets cast from special brass alloy

Includes Adjustable cowbell holder
 Height adjustable tilting double braced tripod stand
 Accessory pouch
 L-shaped tuning key
 Tune Up Oil

ARTIST SERIES

Amadito Valdès

It's been ten years now since the American guitarist Ry Cooder along with a group of Cuban musicians put out a CD with the title "Buena Vista Social Club."

Wim Wenders produced a musical-documentary film about the club and its musicians, with a resulting smash that has exceeded sales of over 5 million. Amadito Valdès played the timbales and became known as "The Golden Stick of the Buena Vista Social Club."

You belong to the so-called "Forgotten Generation" of Cuban music. Shortly after your musical career began in 1960, along came the embargo between Cuba and the United States. How did that affect your work?

I didn't feel like I was cut out from musical development. It's true, we couldn't buy any more American records, but of course we listened to Duke Ellington, Dizzy Gillespie, Miles Davis and all. For us Cuban musicians, things got harder, and it was more difficult to distribute our music. However, we developed our concepts further and created a new style so that for example we could meld our traditional Cuban music with American Jazz. The Cuban music had a new sound that opened new paths and renewed itself.

You played drum set for many years in the biggest Cuban bands until you switched over to Timbales. The drum set is not actually an original Cuban percussion instrument.

That's right; it comes out of the Anglo-Saxon musical tradition. However, it is part of a large spectrum of rhythmical possibilities, and Cuban music easily assimilates other influences. My agenda was to inject our traditional music with the drum set sound, and let the Cuban rhythms take on new colours from this instrument. My dream was to create a comfortable enhancement of our music through the drum set. It shouldn't replace our percussion instruments, but rather take on a new roll within the music. The tradition and flavour of a culture is something one must always respect, however one can find a little sprout of something, join it with the existing traditions, and come up with a whole new development.

What did the success of the film mean for your career?

The cd was more important for me. Before the film was released, we had an European tour of the "Afro-Cuban All Stars" with Ruben Gonzales. For me that was the breakthrough into the international music scene. That's how I became internationally known. Well, with "Buena Vista Social Club." I became an international hit and all, that has led to more offers and requests. But I have not changed my lifestyle. I still live in the same house.

How did it happen that you work with MEINL, a German company?

At the 1993 Expo de Musica in Sao Paolo, the Brazilian representative for MEINL first approached me. A couple of years later, I met with Norbert Saemann at the Jazz Festival in Munich, and he proposed that we make an Artist Series Timbales. For me that was a big acknowledgement. MEINL is something like a title of nobility, that you cannot buy or sell.

What advice can you give to young drummers?

Be respectful of tradition and be open for what is new, practice a lot and experiment even more. And if you would know Amadito, that's not bad at all... (laughs)

"Buena Vista Social Club has not changed my life"



ARTIST SERIES (patented)

The MEINL Artist Series Amadito Valdès Timbales – a tribute to one of the greatest timbaleros ever.

Amadito Valdès



Amadito Valdès, Cuba



Adjustable cowbell holder

AV1BK

- Sizes 14" & 15"
- Material Black powder coated steel
- Features Two worked in flanges
Patented Floatune Tuning System
- Includes Adjustable cowbell holder
Height adjustable tilting double braced tripod stand
Accessory pouch
L-shaped tuning key
Tune Up Oil



MEINL PATENTED FLOATUNE TUNING SYSTEM

Patented Floatune Tuning System



FLOATUNE SERIES (patented)

The patented MEINL Floatune Tuning System used on these timbales works without having to drill into the shell. The result is a voluminous timbale sound with a crisp and warm response, cutting rim shots and a great cascara sound.

MEINL PATENTED FLOATUNE TUNING SYSTEM



Adjustable cowbell holder

- Sizes 13" & 14"
- Material Black powder coated steel
- Features Two worked in flanges
Patented Floatune Tuning System
- Includes Adjustable cowbell holder
Height adjustable tilting double braced tripod stand
Accessory pouch
L-shaped tuning key
Tune Up Oil

T11BK

MARATHON® SERIES

MEINL Marathon® Series Timbales are professionally equipped yet are offered at a more affordable price. They are perfect for the working percussionist or to be included in a drum setup.

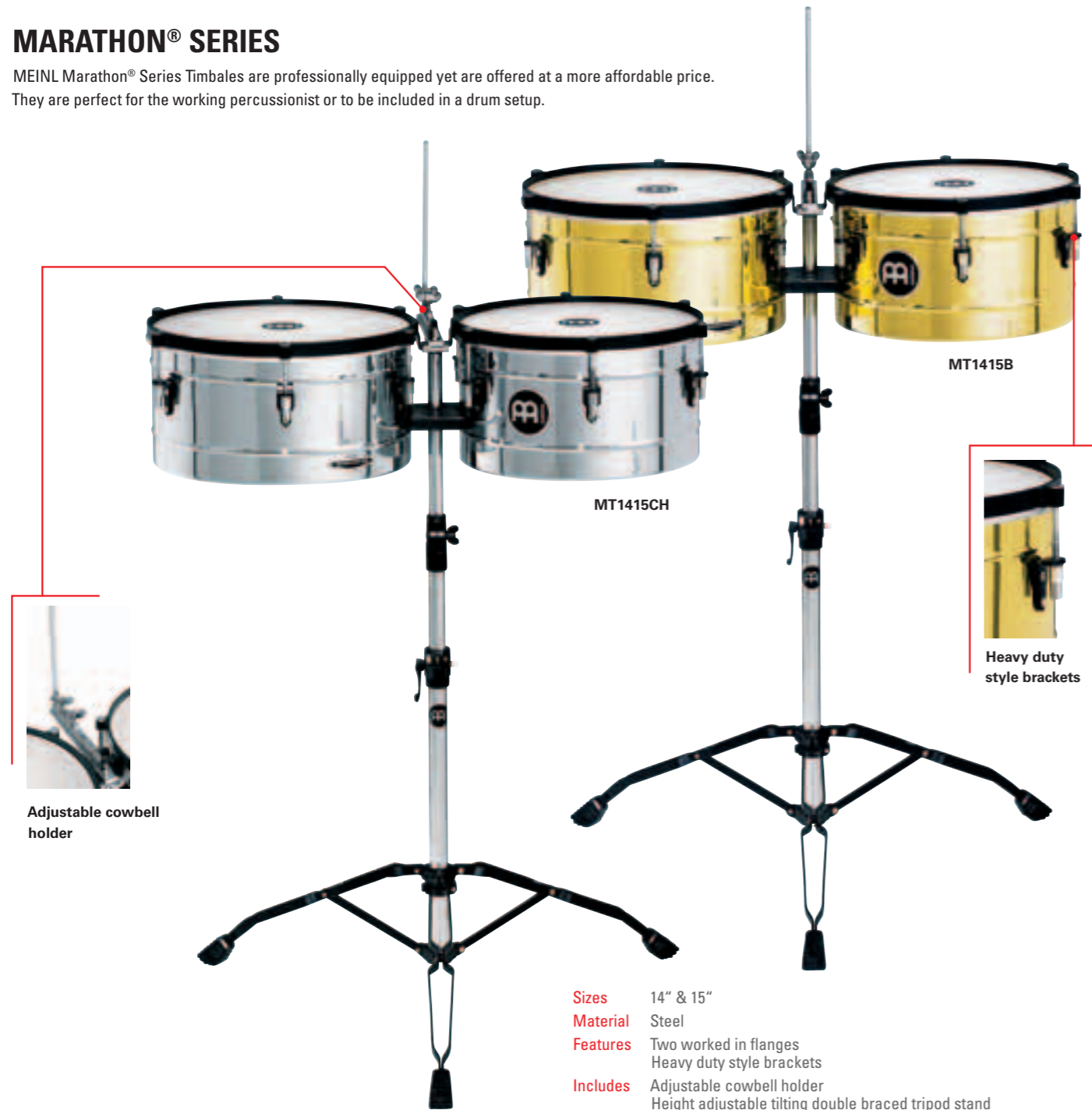

MT1415B

MT1415CH

Heavy duty style brackets

Adjustable cowbell holder

- Sizes** 14" & 15"
- Material** Steel
- Features** Two worked in flanges
Heavy duty style brackets
- Includes** Adjustable cowbell holder
Height adjustable tilting double braced tripod stand
Accessory pouch
L-shaped tuning key
Tune Up Oil
- Finishes** Brass
Chrome

PROFESSIONAL TIMBALE BAG

The MEINL Timbale Bag has two internal compartments (padded separator included) to fit both timbale drums (up to 15") and an outside pocket to fit the stand, cowbells, and sticks.

- Sizes** 14" & 15"
- Material** Heavy duty padded nylon
- Features** External pocket for stand and cowbell
Padded shoulder strap
Carrying grip
Padded separator



MTB



HEADLINER® SERIES

The MEINL Headliner® Series Timbales come in 13" and 14" sizes, are made from chrome plated steel and come with a heavy duty-, height adjustable tilting stand. They provide the classic timbale sound and are the perfect introduction to the joy and passion of timbale playing at an affordable price.

TIMBALE STICKS

The MEINL Timbale Sticks are made out of the finest hand-selected Hickory Wood and are available in four different sizes.

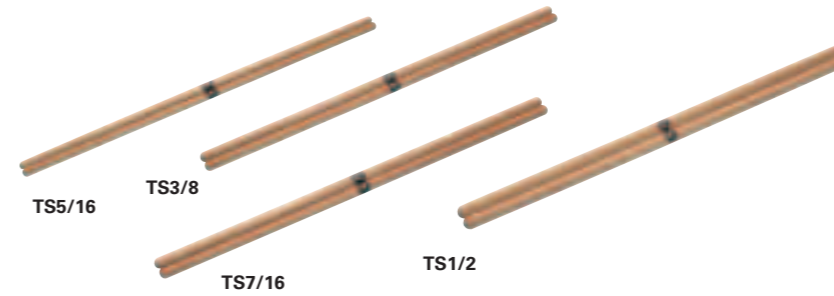

- Sizes** 5/16" x 15", 3/8" x 15", 7/16" x 16 3/4", 1/2" x 16 3/4"
- Material** Hickory Wood



HT1314CH

- Sizes** 13" & 14"
- Material** Steel
- Includes** Height adjustable tilting double braced tripod stand
Tuning key
Wrench
Cowbell holder
- Finish** Chrome

DRUMMER TIMBALE

MINI TIMBALE

The MEINL Drummer and Mini Timbale provide the characteristic timbale sounds and project enough to cut through any band setting. It is a perfect addition to any percussion- or drum set configuration.

Original timbale style bracket & tuning lug



MIT810CH

- Sizes** 13" drummer timbale
8" & 10" mini timbale
- Material** Steel

MDT13CH



- Feature** Strong mounting clamp
- Includes** L-shaped tuning key
Tune Up Oil
- Finish** Chrome

TIMBALES

Model No.	Size	Material	Features	SPARE PARTS					Page
				Head	Rim	Lug	Bracket		
PROFESSIONAL SERIES									
BT1415	14"	•	• • •	HEAD-22	RIM-19	LUG-16	BRACKET-10 chrome	76	
BT1415	15"	•	• • •	HEAD-23	RIM-20	LUG-16	BRACKET-11 chrome, small	76	
ARTIST SERIES, Luis Conte									
LC1	14"	• •	• • • •	HEAD-22	RIM-19	LUG-16	BRACKET-08 brass	77	
LC1	15"	• •	• • • •	HEAD-23	RIM-20	LUG-16	BRACKET-09 brass, small	77	
							BRACKET-10 chrome	77	
							BRACKET-11 chrome, small	77	
ARTIST SERIES, Amadito Valdés									
AV1BK	14"	•	• • •	HEAD-22	RIM-27	LUG-17		79	
AV1BK	15"	•	• • •	HEAD-23	RIM-28	LUG-17		79	
FLOATUNE SERIES									
TI1BK	13"	•	• • •	HEAD-24	RIM-21	LUG-17		79	
TI1BK	14"	•	• • •	HEAD-22	RIM-22	LUG-17		79	
MARATHON® SERIES									
MT1415	14"	•	• • •	HEAD-22	RIM-23	LUG-17	BRACKET-12	80	
MT1415	15"	•	• • •	HEAD-23	RIM-24	LUG-17	BRACKET-12	80	
HEADLINER® SERIES									
HT1314	13"	•	• • •	HEAD-24	RIM-37	LUG-26	BRACKET-18	81	
HT1314	14"	•	• • •	HEAD-22	RIM-38	LUG-26	BRACKET-18	81	
DRUMMER TIMBALE									
MDT13CH	13"	•	• • •	HEAD-43	RIM-31	LUG-21	BRACKET-13	81	
MINI TIMBALE									
MIT810CH	8"	•	• • •	HEAD-41	RIM-29	LUG-21	BRACKET-13	81	
MIT810CH	10"	•	• • •	HEAD-42	RIM-30	LUG-21	BRACKET-13	81	

SPARE PARTS FOR STANDS	
Timbale Stand, chrome	TMT
Cowbell Holder, complete for MEINL Timbales	STAND-01
Cowbell Holder, complete for HT1314 Timbales	HDSTAND-01
Memory Clamp, chrome for middle stand tube	STAND-07
Memory Clamp, black for middle stand tube	STAND-08
Memory Clamp, chrome for lower stand tube	STAND-09
Memory Clamp, black for lower stand tube	STAND-10
Fast Lock Set, chrome	STAND-14
Fast Lock Set, black	STAND-15
Rubber Feet (set of 3 pcs.) for Timbales Stand	STAND-16

OTHER PARTS	
Lug Oil	SPARE-09
Tuning Key, 13 mm + 14 mm, L shaped, chrome	KEY-02



DIVERSITY IN MATERIALS

MEINL has a great variety of different sounding timbales due to the diversity of materials used in making the shells. Available models include German B8 cymbal bronze, solid brass, stainless steel, black powder coated steel, chrome plated steel, and brass plated steel.



HAMMERED SHELLS

Extensively hammered shells (Artist Series Luis Conte Timbales) provide the classic dry cascara sound and support the sharpness and projection of the drums.



PATENTED FLOATUNE TUNING SYSTEM

The patented Floatune Tuning System works without having to drill into the shell (Artist Series Amadito Valdés and Floatune Series timbale models). The bottom rim is positioned around the shell before the bottom is flanged. When the head is tensioned the lower rim is drawn upward against the tuning flange and the head and upper rim are drawn downward over the shell.



FLARED OUT BOTTOM EDGE

The Cuban Style flared out bottom edge increases the projection of the timbale (Artist Series Luis Conte and Professional Series Timbales).



WORKED IN FLANGES AND CAST BRACKETS

Two flanges are worked into the shell to increase stability. Brackets cast from special brass alloy.



APPLYING THE LOGO FROM UNDERNEATH THE HEADS (patent pending)

All MEINL timbale heads are now being manufactured with the MEINL logo applied onto the head's surface from underneath (patent pending).

Both drummers and percussionists alike have experienced the same annoying situation with plastic heads: Extensively playing causing the colour of the logo-print to wear out. Not only does it create an unattractive look, but moreover the colour clings to the tip of the drumstick resulting in unwanted black stains that appear on other drumheads, cymbals, or other instruments. This new and original MEINL innovation prevents the colouring of the logo from wearing off and helps to keep your instruments nice and clean.



SAMBA

The MEINL Samba Series is a line of innovative Brazilian percussion instruments. Its variety of different and authentic sounds, innovative features and wide range of accessories combined with light weight materials designed for comfortable playing makes this series invaluable to all percussionists.

FLOATUNE TAMBORIMS (patented)

Tamborims are played with a plastic stick while the other hand changes the pitch of the drum. It has a bright, loud, and cutting sound. MEINL offers a variety of tamborims all made from several high quality materials for more sound options.



Applying the logo from underneath the head to prevent from wearing off (patent pending)

Light weight ABS guarantees great stability and comfortable handling

- Size** 6"
- Material** ABS
Aluminum
Brass plated steel
Chrome plated steel
Rubber Wood (*Hevea brasiliensis* Muell.-Arg.)
- Features** Patented Floatune Tuning System
Counter sunk bolt lugs
Replaceable synthetic heads
- Includes** German "Pfennig" as tuning key



Patented Floatune Tuning System

TAMBORIM STICKS



- Material** Plastic
- Colours** BK = Black
R = Red

PROFESSIONAL TAMBORIM BAG

The MEINL Tamborim Bag is made from heavy duty padded nylon with reinforced stitching and is equipped with a double-slide zipper and a shoulder strap. It protects your instruments and provides hassle free transportation.



- Size** 6"
- Material** Heavy duty padded nylon
- Features** Double-slide zipper
Shoulder strap
External pocket



Perfect fit

WOOD PANDEIROS

The Pandeiro is played with one hand while the other alters the pitch of the drum. Solid jingles produce a brilliant and cutting sound.



- Sizes** 10"
12"
- Material** Rubber Wood (*Hevea brasiliensis* Muell.-Arg.)
- Features** Counter sunk bolt lugs
Chrome plated hardware
Replaceable hand selected goat heads
- Includes** Tuning key
- Colour** CN-M = Chest Nut
- Finish** Matt

PROFESSIONAL PANDEIRO BAGS

The MEINL Pandeiro Bags are made from heavy duty padded nylon with reinforced stitching and are equipped with a double-slide zipper and a shoulder strap. They protect your instruments and provide hassle free transportation.



- Sizes** 10"
12"
- Material** Heavy duty padded nylon
- Features** Double-slide zipper
Shoulder strap
External pocket

FIBERGLASS QWEEKA

While one hand rubs the internal bamboo shaft with a moist cloth, the other hand controls the pressure of the head thereby changing the pitch of the tone.



- Size** 8"
- Material** Premium fiberglass
- Features** Floatune Tuning System
Hand selected goat head
- Includes** Tuning key
- Colour** R = Red



- Sizes** 6"
10"
- Material** Aluminum
- Features** Counter sunk bolt heads (QW10)
Hand selected goat heads
- Includes** Tuning key



Internal bamboo shaft

NEW

ALUMINUM QWEEKAS

MEINL now offers two Qweekas made from light weight aluminum. Their light weight and solid construction makes them perfect for street Samba.



ALUMINUM CAIXAS

With shells made from premium aluminum, these MEINL Caixas produce the classic bright and cutting sound with penetrating rim shots that these instruments are supposed to deliver. Its light weight yet solid construction makes it perfect for street Samba.

- Sizes** 12" x 4 1/2"
14" x 4"
- Material** Aluminum
- Features** Replaceable synthetic heads
Counter sunk bolt heads
Steel snare wires
Professional snare throw-off mechanism
- Includes** Tuning key



PROFESSIONAL CAIXA BAGS

NEW

The MEINL Caixa Bags are made from heavy duty padded nylon with reinforced stitching and are equipped with a double-slide zipper, a shoulder strap, and a carrying grip. They protect your instruments and provide hassle free transportation.

- Sizes** 12" x 4 1/2"
14" x 4"
- Material** Heavy duty padded nylon
- Features** Double-slide zipper
Extra pocket for spare heads
Shoulder strap
Carrying grip
External pocket



SAMBA STICKS

MEINL offers a wide assortment of Samba Sticks for Tamborims, Repiniques, and other Samba instruments in order to achieve their authentic sounds. All sticks are made from high quality materials and ensure a comfortable playing.

- Material** Plastic
- Sizes** SST1-S = Stick, short version
SST1-R = Stick, regular version
SST1-L = Stick, long version
SST3-S = Triple stick, short version
SST3 = Triple stick
SST7 = Sevenfold stick

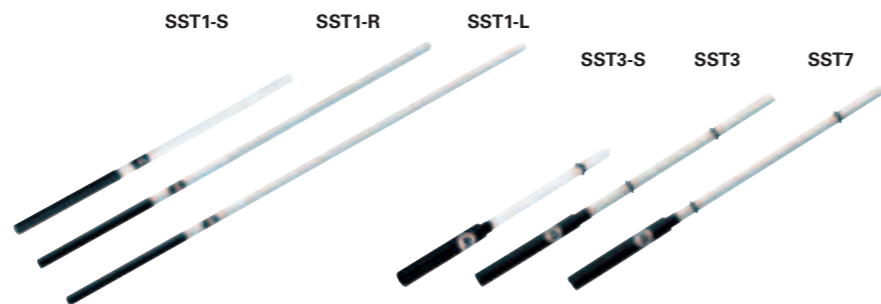

ALUMINUM REPINIKUES

The Repinique is played with a stick while the other hand is used for open tones and slaps. MEINL offers two sizes made from premium aluminum.

- Sizes** 10" x 10"
12" x 12"
- Material** Aluminum
- Features** Counter sunk bolt heads
Chrome plated hardware
Replaceable synthetic heads
6 tuning lugs (10" model)
8 tuning lugs (12" model)
- Includes** Tuning key



WOOD REPINIQUE

For an especially warm and harmonic sound, MEINL offers a Repinique made from wood.



- Size** 12" x 10"
- Material** Rubber Wood
(*Hevea brasiliensis* Muell.-Arg.)
- Features** Counter sunk bolt heads
Chrome plated hardware
Replaceable synthetic heads
8 tuning lugs
- Includes** Tuning key
- Colour** AB = African Brown
- Finish** Hi Gloss

PROFESSIONAL REPINIQUE BAGS

The MEINL Repinique Bags are made from heavy duty padded nylon with reinforced stitching and are equipped with a double-slide zipper, a shoulder strap, and a carrying grip. They protect your instruments and provide hassle free transportation.



SAMBA BELT

MEINL offers a high quality belt to ensure a safe and comfortable playing of the Surdo and Repinique. It can be placed around the player's shoulder or hip depending on the required playing position.

- Material** Cotton
- Features** Length adjustable
Adjustable shoulder padding
Strong attachment hooks
- Colour** R = Red



ALUMINUM SURDOS

The deep sound of the Surdo is the heartbeat of Samba music. It is played with a felt beater. MEINL offers several sizes made from premium aluminum.



- Sizes** 16" x 20"
18" x 22"
20" x 24"
22" x 24"
- Material** Aluminum
- Features** Counter sunk bolt heads
Chrome plated hardware
Replaceable synthetic heads
8 tuning lugs (16" & 18" models)
10 tuning lugs (20" & 22" models)
- Includes** Tuning key

STAND ALONE ALUMINUM SURDOS

Having a Surdo hanging around the player's shoulders and neck can be exhausting when played that way over a long period of time. MEINL percussion offers stand alone Surdos that are equipped with sturdy, height adjustable legs placed on the floor while playing.



- Sizes** 16" x 20"
18" x 22"
20" x 24"
22" x 24"
- Material** Aluminum
- Features** Height adjustable legs
Counter sunk bolt heads
Chrome plated hardware
Replaceable synthetic heads
8 tuning lugs (16" & 18" models)
10 tuning lugs (20" & 22" models)
- Includes** Tuning key

PROFESSIONAL SURDO BAGS

The MEINL Surdo Bags are made from heavy duty padded nylon with reinforced stitching and are equipped with a double-slide zipper, padded backpack straps, and a carrying grip. They protect your instruments and provide hassle free transportation.



- Sizes** 16" x 20"
18" x 22"
20" x 24"
22" x 24"
- Material** Heavy duty padded nylon
- Features** Double-slide zipper
Padded backpack straps
Carrying grip
External pocket

SAMBA BEATERS

MEINL offers a wide assortment of Samba Beaters for Surdos and Repiniques in order to achieve their authentic sounds. All beaters are made from high quality materials and ensure a comfortable playing.



- SB1 = 15" long, aluminum stick with 2" felt beater
- SB2 = 16" long, wood stick with 2" felt beater
- SB3 = 16" long, wood stick with 2 1/2" felt beater
- SB4 = 16" long, wood stick with 2" leather beater
- SB5 = 16" long, wood stick with 3" bushy felt beater



HANDHELD MODELS

The unique feature of the MEINL Handheld Models is a wide and comfortable grip. Ideal for street percussion.

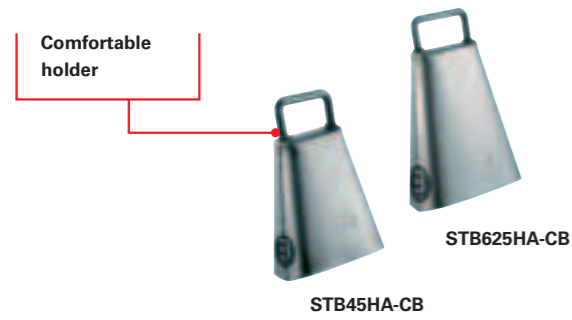

Sizes 4 1/2"
6 1/4"
Material Special steel alloy
Feature Comfortable holder
Finish Hand brushed steel

HANDHELD MODELS, ALUMINUM

Another true MEINL innovation! They are the perfect handheld bells for Samba music due to their light weight and comfortable grip which keeps the player from tiring, allowing for energetic playing. Aluminum also enables a more soft and musical tone.

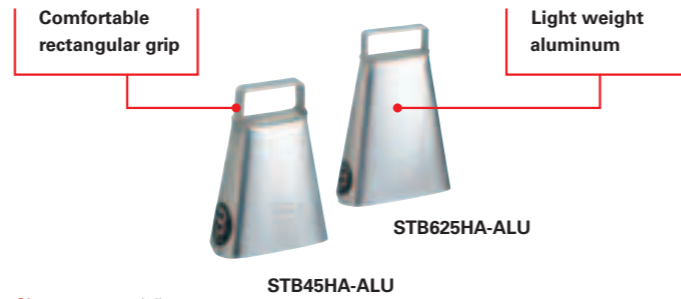

Sizes 4 1/2"
6 1/4"
Material Aluminum
Features Light weight construction
Comfortable rectangular grip

A-GO-GO STEEL FINISH MODELS

These MEINL A-Go-Go Bells are tonally matched especially for the requirements of South American rhythms.



Sizes Small
Large
Material Special steel alloy
Includes Mounting clamp for small model
Finish Hand brushed steel

A-GO-GO CHROME FINISH MODELS

These highly polished A-Go-Go Bells offer a bright sound and are equipped with a flexible connection. Ideal for Samba style music.

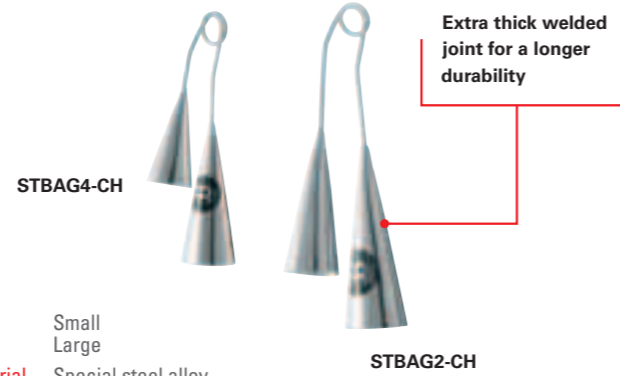

Sizes Small
Large
Material Special steel alloy
Feature Flexible connection
Finish High polished chrome

ALUMINUM SAMBA SHAKERS

The MEINL Samba Shakers are the ideal instruments for street Samba due to their voluminous sound and their ability to cut through loud musical environments. Their shells are made from thin aluminum which, when combined with solid steel shots, produce a warm, penetrating, and cutting shaker sound.

SINGLE SHAKERS



SSH1-S

SSH1-M

SSH1-L

Sizes Small
Medium
Large
Material Aluminum

DOUBLE SHAKERS



SSH2-S

SSH2-M

SSH2-L

Sizes Small
Medium
Large
Material Aluminum

TRIPLE SHAKERS

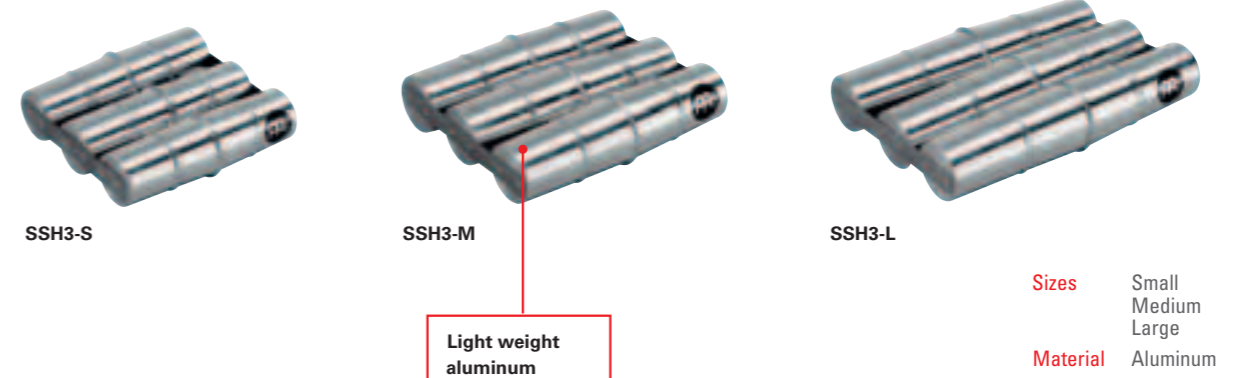

SSH3-S

SSH3-M

SSH3-L

Sizes Small
Medium
Large
Material Aluminum

ROCAR

NEW

The MEINL Rocar is equipped with 20 pairs of solid jingles mounted onto a wooden bar. Due to the Rocar's light weight, it is suited for parades, festivals and many other occasions.

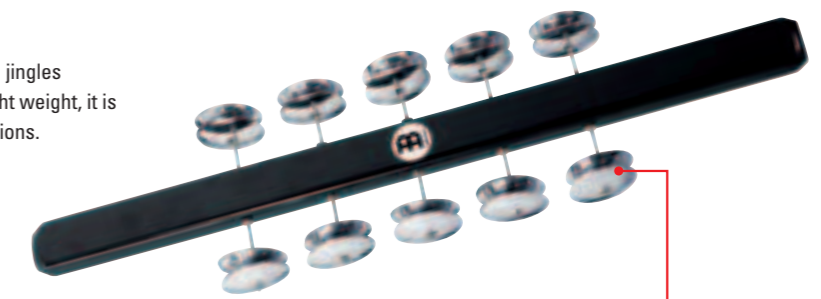

RC1BK

20 pairs of solid jingles

Material Rubber Wood
(*Hevea brasiliensis* Muell.-Arg.)
Colour BK = Black
Feature 20 pairs of solid jingles



SAMBA

Model No.	Size	Material	Features	SPARE PARTS				Page
				Head	Rim	Lug	Bracket	
FLOATUNE TAMBORIMS								
TBR06	6"	• • • • •	• • • • •	HEAD-40	RIM-32	LUG-20		86
WOOD PANDEIROS								
PA10	10"	• • • • •	• • • • •	HEAD-44	RIM-33	LUG-24	BRACKET-19	87
PA12	12"	• • • • •	• • • • •	HEAD-45	RIM-34	LUG-24	BRACKET-19	87
FIBERGLASS QWEEKA								
QW7	8"	• • • • •	• • • • •	HEAD-13	RIM-10	LUG-13		87
ALUMINUM QWEEKAS								
QW6	6"	• • • • •	• • • • •	HEAD-57	RIM-44	LUG-35		87
QW10	10"	• • • • •	• • • • •	HEAD-58	RIM-45	LUG-36		87
ALUMINUM SURDOS								
SU16	16"	• • • • •	• • • • •	HEAD-59	RIM-46 (Top)	LUG-37		90
SU18	18"	• • • • •	• • • • •	HEAD-49	RIM-40 (Top)	LUG-30		90
SU20	20"	• • • • •	• • • • •	HEAD-46	RIM-35 (Top)	LUG-27		90
SU22	22"	• • • • •	• • • • •	HEAD-50	RIM-41 (Top)	LUG-31		90
STAND ALONE ALUMINUM SURDOS								
SU16-L	16"	• • • • •	• • • • •	HEAD-59	RIM-46 (Top)	LUG-37		91
SU18-L	18"	• • • • •	• • • • •	HEAD-49	RIM-40 (Top)	LUG-30		91
SU20-L	20"	• • • • •	• • • • •	HEAD-46	RIM-35 (Top)	LUG-27		91
SU22-L	22"	• • • • •	• • • • •	HEAD-50	RIM-41 (Top)	LUG-31		91
ALUMINUM CAIXAS								
CA12	12"	• • • • •	• • • • •	HEAD-51	RIM-42 (Top)	LUG-33		88
CA14	14"	• • • • •	• • • • •	HEAD-52	RIM-43 (Top)	LUG-34		88
ALUMINUM REPINQUES								
RE10	10"	• • • • •	• • • • •	HEAD-48	RIM-39 (Top)	LUG-29		89
RE12	12"	• • • • •	• • • • •	HEAD-47	RIM-36 (Top)	LUG-28		89
WOOD REPINIQUE								
RE12	12"	• • • • •	• • • • •	HEAD-47	RIM-36	LUG-32		89
OTHER PARTS								
A Go Go Bell Holder				STBAGH				
Tuning Key for Pandeiro				KEY-08				
Tuning Key for Caixa				KEY-09				
Tuning Key for Surdo and Repinique				KEY-10				



LIGHT WEIGHT MATERIALS

Samba is mostly played in the streets while marching along to the rhythms of the music. Therefore it is essential that the weight of the instruments is as light as possible, ensuring hours of comfortable and ergonomically sound playing without lacking power and projection.

Beginning and professional players alike will appreciate the fact that MEINL percussion is using only light weight, yet durable and robust aluminium for crafting Surdos, Repiniques, Caixas, Qweekas, Handheld Bells and Samba Shakers.



COUNTER SUNK BOLT HEADS

The attention to detail is what sets MEINL percussion instruments apart. Counter sunk bolt heads on MEINL Qweeka (QW10), all Repiniques and all Surdos allow for energetic playing without having to worry about the bolt heads of the tuning lugs being in the way of the beater. Little details that make all the difference in the world.

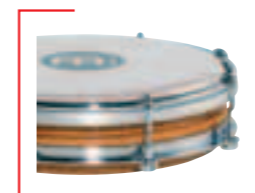

PATENTED FLOATUNE TUNING SYSTEM

The patented MEINL Floatune Tuning System makes drilling holes into the shell unnecessary while enhancing the resonance of the drum and increasing its projection.



STAND ALONE SURDOS

Having a Surdo hanging around the player's shoulders and neck can be exhausting when played that way over a long period of time. MEINL percussion offers stand alone Surdos that are equipped with sturdy legs placed on the floor while playing.



APPLYING THE LOGO FROM UNDERNEATH THE HEADS (patent pending)

All MEINL Samba Instruments equipped with plastic heads are now being made with the MEINL logo applied onto the head's surface from underneath (patent pending). This new and original MEINL innovation prevents the colouring of the logo from wearing off and helps to keep your other instruments nice and clean.



WIDE RANGE OF SAMBA ACCESSORIES

To complete the assortment, a wide range of accessories such as bags, sticks, beaters and a belt are offered for all MEINL Samba Instruments.

THE FUTURE OF SHAKERS FROM MEINL



Bill Saragosa, Germany



NEW

BILL SARAGOSA – SPARK SHAKERS

MEINL Percussion proudly introduces a new line of percussion instruments developed with the help of percussion artist Bill Saragosa.

Bill Saragosa is well known for his highly original designs. The shapes and sounds of his creations are anything but ordinary. His instruments are a welcome addition to the percussion arsenal of professional and recreational musicians alike.

“I am thrilled that my work has received the attention of MEINL Percussion and that we are able to offer my designs on a world-wide scale. I strongly recommend you, the player, to explore the full potential of these compact, ergonomic instruments. You will find a surprising resource through new dimensions of sound.”

SPARK SHAKER

The MEINL Spark Shaker is a very versatile instrument, and is unlike anything heard before. The sparkling, chirping, splashing tones readily mix with almost any musical flavour. The pod-like shape fits easily into the hand and may be manipulated for many interesting effects. Spark Shakers may be played in pairs, or in combination with other shakers for even more variations. It's as unique as the player who knows how to use it.

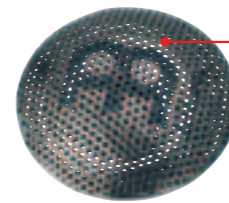

SH16

Circular motion enables a unique rattling sound

Size Medium
Materials Shaker: Coated steel
 Pellets: Coated steel
Finish Black nickel

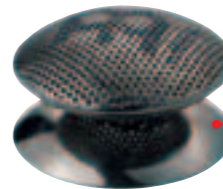

SH17

Screw-mounted disc enables a tunable pitch

Size Medium
Materials Shaker: Coated steel
 Pellets: Coated steel
Finish Black nickel

HEADED SPARK SHAKER

One side of the MEINL Headed Spark Shaker is a drum head! Premium goatskin and a steel shell provide a rattling combination of crisp warm tones and a bright metal timbre. Used alone or in combination with the Spark Shaker, its highly variable and “bendable” sound provides a very unique musical character.

Size Medium
Materials Shaker: Coated steel
 Pellets: Coated steel
 Goat head
Finish Black nickel



SH18



Side view

Sensational effects are produced when combined with another Spark Shaker

ALUMINUM SHAKERS, OCTAGONAL

MEINL's Octagonal Aluminum Shakers come in two different sizes. Both have a broad dynamic range with lots of volume.



SH8BK



SH88BK

Sizes Small
 Medium
Material Aluminum
Colour BK = Black

ALUMINUM JINGLE SHAKER

The MEINL Aluminum Jingle Shaker (designed by Juan Carlos Melian) has two pairs of steel jingles which are attached in one row to an octagonal aluminum shaker.

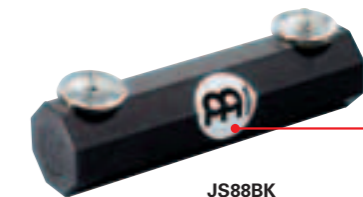

JS88BK

By tilting the shaker 90° to the front the jingles start to click on the beat

Size Medium
Materials Shaker: Aluminum
 Jingles: Steel
Colour BK = Black

STUDIO SHAKER

MEINL's Studio Shaker was designed to meet all the requirements necessary in today's session world. It delivers a very tasteful and delicate shaker sound with a warm overall tone and a very well balanced frequency spectrum.



SH10-L-BK

Size Large
Material Plastic
Colour BK = Black

ALUMINUM SHAKERS, ROUND

The MEINL Round Aluminum Shakers were designed to cut through loud live music. Available are two different versions.

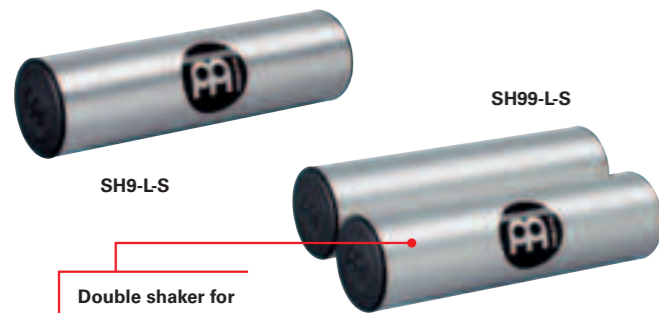

SH9-L-S

SH99-L-S

Double shaker for a louder sound

Size Large
Material Anodized aluminum
Features Available as a single, or double shaker
Colour S = Silver

WOOD SHAKERS

Made from a combination of selected woods, these new MEINL Wood Shakers offer a nice array of alternative sounds. A slightly softer attack combined with a generally warmer sound.

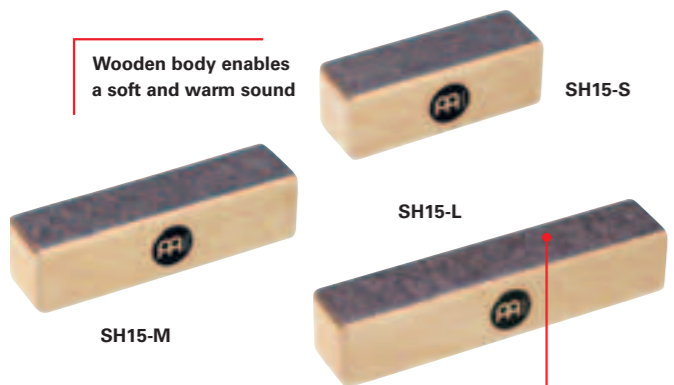

Wooden body enables a soft and warm sound

SH15-S

SH15-L

SH15-M

Black Makah-Burl

Sizes Small
Medium
Large
Materials Rubber Wood
(*Hevea brasiliensis* Muell.-Arg.)
Top and Bottom: Black Makah-Burl

FIBERGLASS SHAKERS

These MEINL Shakers are made from premium fiberglass for more durability and better sound quality. They are light weight and very comfortable to play.

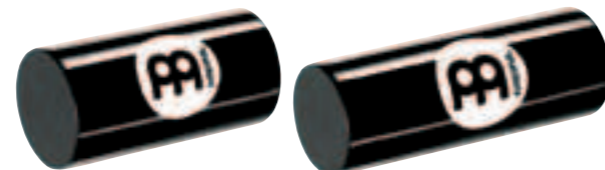

SH7-M-BK

SH7-L-BK

Sizes Medium
Large
Material Premium fiberglass
Colour BK = Black

SHAKER HOLDER

The MEINL Shaker Holder (designed by Jen Lowe) firmly attaches to any common rod. With its length adjustable specially shaped claws it holds any size shaker in a comfortable position for quick reach.

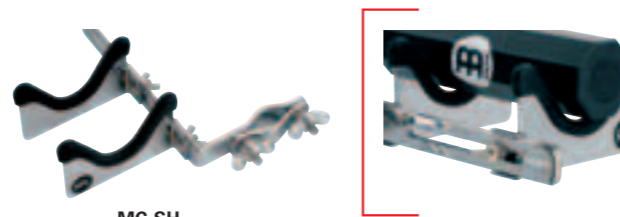

MC-SH

Material Chrome plated steel
Features Rubber pads against scratching
Length adjustable
Strong mounting clamp

SKIN SHAKER

The MEINL Skin Shaker combines two different materials into one unique instrument. It produces very experimental sounds and works perfectly in modern music productions.

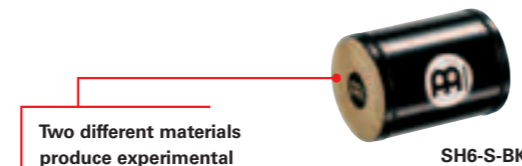

SH6-S-BK

Two different materials produce experimental sounds

Size Small
Materials Plastic with natural skin side caps
Colour BK = Black

U.F.O. SHAKER

The MEINL U.F.O. Shaker produces an extreme mellow and smooth sound and less attack. Therefore it perfectly fits in jazzy and classical arrangements and also ideal for world music.

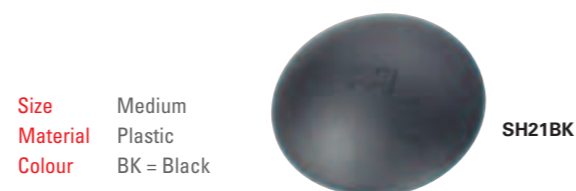

SH21BK

Size Medium
Material Plastic
Colour BK = Black

WAH-WAH SHAKER

The MEINL Wah-Wah Shaker is another unique and innovative instrument, offering yet another voice to a percussionist's range of sounds. The shaker has two chambers which are separated by a plastic membrane. The MEINL Wah-Wah Shaker offers a wide sound spectrum and is a lot of fun to play.

Size Medium
Materials Wooden body and plastic chamber
Colour BK = Black



SH20BK

By covering and uncovering the sound hole, a "wah-wah" effect can be achieved

LOOP SHAKER (patent pending)

The MEINL Loop Shaker has a crackling bright sound with many dynamics, and is easy to control. It is very responsive to hand pressure and movement, giving it a soft or loud voice as needed. The MEINL Loop Shaker has applications in practically any musical setting.

Size Medium
Material Plastic
Colour BK = Black



SH3BK

Loud and penetrating sound due to the many holes

ARTIST SERIES

The two versions have been designed according to master percussionist Luis Conte exact requirements. "My shaker sound is as smooth as silk" is how Luis described their sound.



SH4BK

More voluminous yet delicate sound

Size Medium
Material Plastic
Feature Two individual shakers connected as one instrument

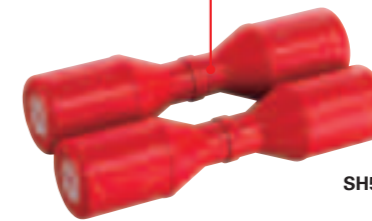

SH5R

Very subtle and smooth tone

Colours Live Shaker: BK = Black
Studio Shaker: R = Red

FIBERGLASS MINI SHAKER

The MEINL Mini Shaker is made from premium fiberglass and offers a smooth and soft shaker sound which blends well with all music and always delivers the right accents.

Size Large
Material Premium fiberglass
Colour R = Red



SH11-L-R

FIBERGLASS JINGLE MINI SHAKER

The MEINL Fiberglass Jingle Mini Shaker features a pair of aluminum jingles which are attached to the shaker and add an additional flavour to its sound.

Size Large
Materials Premium fiberglass
Jingles: Aluminum
Feature Additional jingles
Colour R = Red



SH12-L-R



REALPLAYER STEELBELLS

MEINL's Realplayer Steelbells are hand made using a special steel alloy. The parts are welded together in a continuous seam and sealed with a protective coating.



CHROME FINISH MODELS

These highly polished chrome finished models are not only visually bright, they also satisfy all of the sonic requirements for South American rhythms.

STEEL FINISH MODELS

The pitches of these Steelbells form a diatonic scale which makes it easy to use multiple bell combinations in any musical setting.

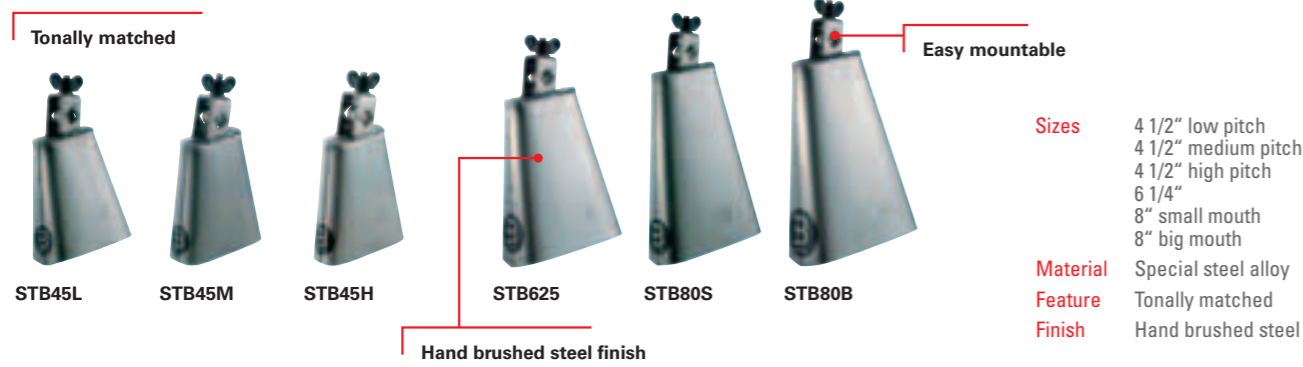

COWBELL BASS DRUM HOLDER

The MEINL Cowbell Holder attaches firmly to the bass drum hoop. Rubber pads prevent scratches on the hoop.

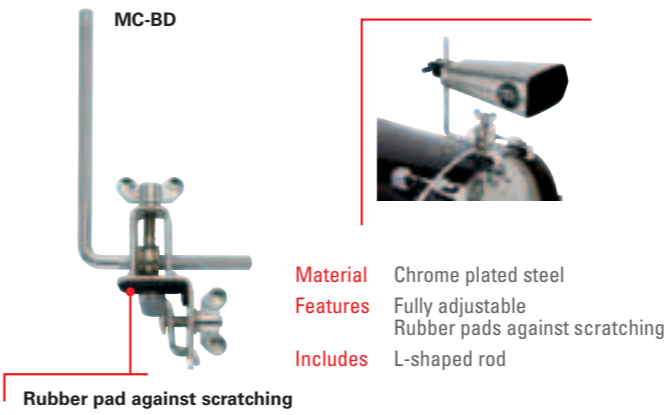

ARTIST SERIES

Kenny Aronoff says: "My Artist Series Signature Cowbells are the ultimate drummer's bells. Playing live they cut through and have very nice tones. Their recording characteristics are outstanding too."

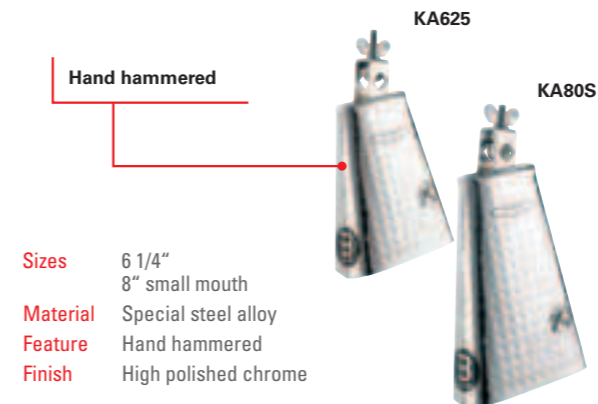

HAND HAMMERED MODELS

The strong fundamental tone of these Steelbells make them a unique alternative to all other bells on the market. Each Steelbell has its own character.

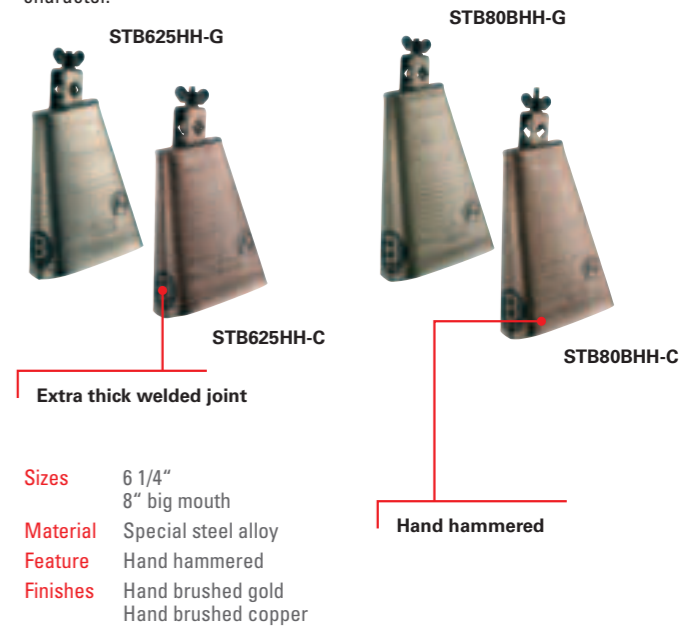

PEDAL MOUNT

The MEINL Pedal Mount fits on all common bass drum pedals and firmly holds cowbells, blocks, or tambourines. It is height adjustable and contains metal spikes attached to the bottom of the legs, holding the entire unit in place without movement.

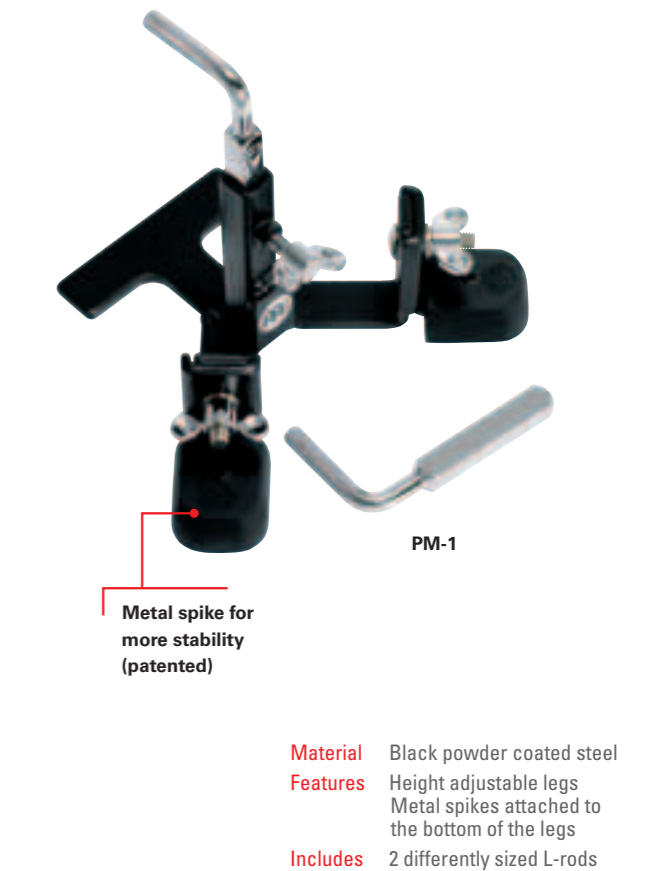

BLACK FINISH MODELS

The MEINL Black Finish Models cowbells have been especially designed to meet all of the requirements of today's modern percussionists and drum set players.



- Sizes** 4 3/4"
5 1/4"
8 1/2"
- Material** Special steel alloy
- Feature** Muffled sound
- Finish** Black powder coated steel

TRIPLE BELL

The three pitch-matched bells combined in one unit, offer the modern percussionist a variety of new playing options. Mounted in a drum set, they can be used in many patterns, techniques and styles. Used in a traditional percussion set up, the MEINL Triple Bell adds new colours and means of expression to the arsenal of sounds.

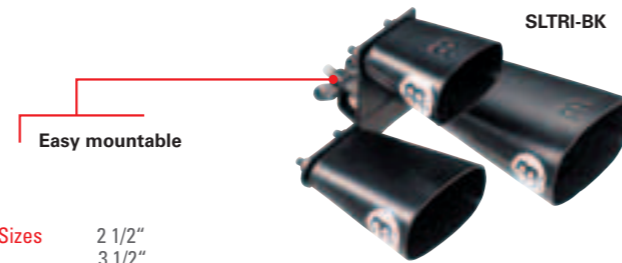

- Sizes** 2 1/2"
3 1/2"
5"
- Material** Special steel alloy
- Feature** Muffled sound
- Finish** Black powder coated steel

HAND MODELS

These Bongo Bells easily cut through any high volume performance and are comfortable to hold. They are perfect for a classic bongo pattern.

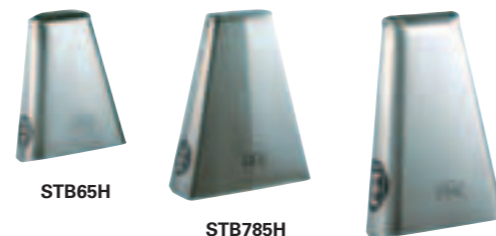

- Sizes** 6.5"
7.85"
8.15"
- Material** Special steel alloy
- Finish** Hand brushed steel

COWBELL BEATERS

MEINL offers a regular and professional cowbell beater for more sound options.

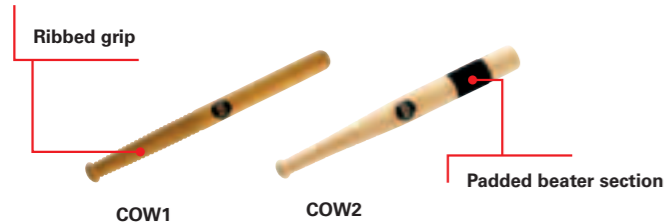

- Material** Rubber Wood (*Hevea brasiliensis* Muell.-Arg.)
- Features** Ribbed grip
Padded beater section

HANDMATE

The MEINL Handmate is a professional cowbell beater which can be mounted in a setup. This allows hitting the cowbell by hand while playing another instrument.

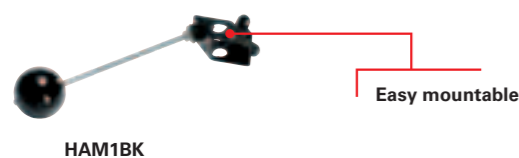

- Material** Steel construction with a wooden ball
- Feature** Fully adjustable



ABS TAMBOURINES

MEINL Hand and Set Up Tambourines (design protected by a utility model) have a distinct design advantage due to the construction of the ABS frame. Unlike other tambourines, MEINL's utilizes several different parts in the frame which are assembled into a type of "sandwich." This results in unsurpassed durability.

TAMBOURINES, STEEL JINGLES

These ergonomically shaped tambourines are available as hand held or mountable versions. The durable ABS frame allows hard hitting and energetic hand playing. Nickelsilver plated steel jingles produce a bright sound that projects well.

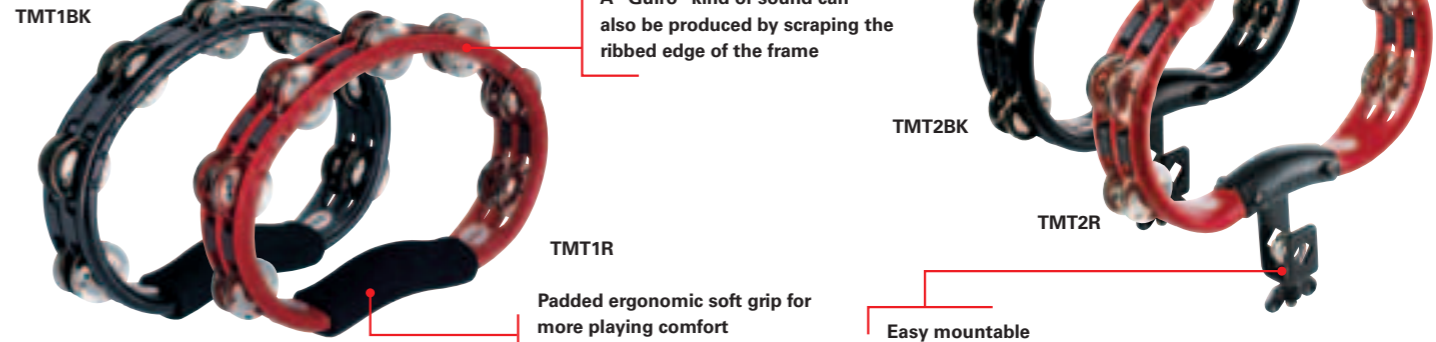

- Materials** Jingles: Nickelsilver plated steel
Frame: ABS
- Features** Padded soft grip for more playing comfort
Ergonomic design
Available as hand held or mountable versions
Guiro style playing surface
"Sandwich" construction
- Colours** BK = Black
R = Red

TAMBOURINES, BRASS JINGLES

The durable ABS frame allows hard hitting and energetic hand playing. They deliver a very warm, yet cutting sound.



- Materials** Jingles: Solid brass
Frame: ABS
- Features** Padded soft grip for more playing comfort
Ergonomic design
Available as hand held or mountable versions
Guiro style playing surface
"Sandwich" construction
- Colour** BK = Black

TAMBOURINES, ALUMINUM JINGLES

The hand held versions are extremely light weight for extensive and energetic playing. The mountable version is built to resist hard hitting.

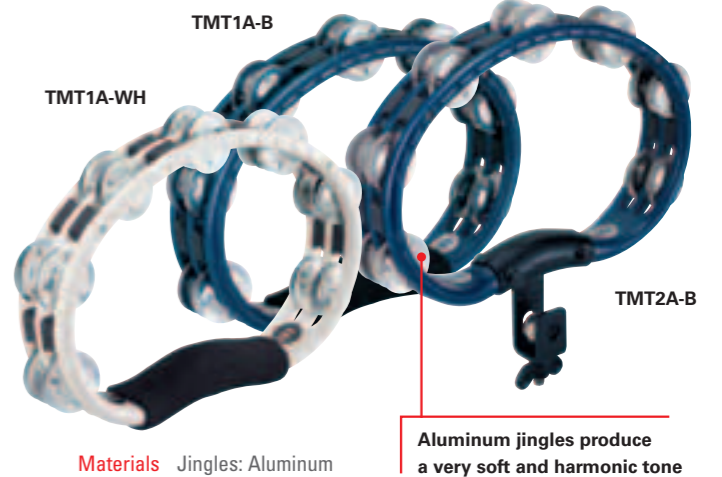

- Materials** Jingles: Aluminum
Frame: ABS
- Features** Padded soft grip for more playing comfort
Ergonomic design
Available as hand held or mountable versions
Guiro style playing surface
"Sandwich" construction
- Colours** B = Blue
WH = White (hand held only)

TAMBOURINE HOLDER

The tambourine holder converts a MEINL Hand Held Tambourine into a set up tambourine. It holds it in place and is made to resist even the hardest hits.

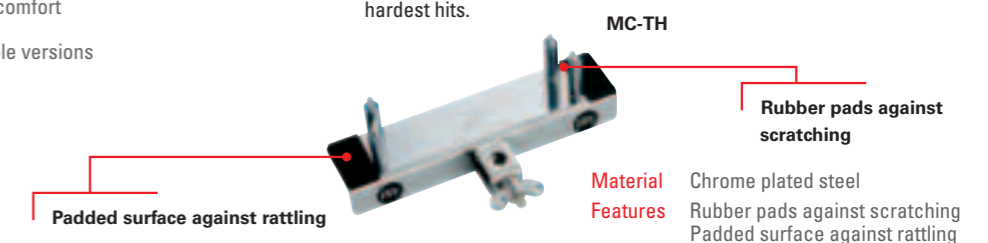

- Material** Chrome plated steel
- Features** Rubber pads against scratching
Padded surface against rattling

WOOD TAMBOURINES

MEINL's Wood Tambourines are made from a sturdy frame with jingles available in different materials, resulting in various sound possibilities. Their ergonomically shaped handle and light weight enable energetic playing.

WOOD TAMBOURINES, STEEL JINGLES

Featuring 1 or 2 row versions. The MEINL Wood Tambourines with nickelsilver plated steel jingles produce a bright sound that projects well.



Sizes 1 row
2 rows

Materials Jingles: Nickelsilver plated steel
Wooden frame

Colour AB = African Brown

ALUMINUM JINGLES

Featuring 1 or 2 row versions, the MEINL Wood Tambourines with aluminum jingles deliver a very soft and harmonic sound. They are also light weight for extensive and energetic playing.



Sizes 1 row
2 rows

Materials Jingles: Aluminum
Wooden frame

Colour AB = African Brown

Super light weight due to the aluminum jingles

BRASS JINGLES

Featuring 1 or 2 row versions. Solid brass jingles deliver a distinctively warm, and cutting sound.



Sizes 1 row
2 rows

Materials Jingles: Solid brass
Wooden frame

Colour AB = African Brown

HEADED WOOD TAMBOURINES, STEEL JINGLES

With steel jingles and the finest hand selected goat heads firmly attached to the tambourine, this instrument delivers a subtle and gentle tone when played by hand and a voluminous and rich sound.



Sizes 1 row
2 rows

Materials Jingles: Nickelsilver plated steel
Head: Hand selected goat heads
Wooden frame

Colour AB = African Brown

Hand selected goat head

Firmly attached

BRASS JINGLES

With brass jingles and fine hand selected goat heads firmly attached, these tambourines deliver a distinctively warm and cutting sound when played by hand or stick. Featuring 1 or 2 row versions.



Sizes 1 row
2 rows

Materials Jingles: Solid brass
Head: Hand selected goat heads
Wooden frame

Colour AB = African Brown

Solid brass jingles deliver a warm and cutting sound

HAND DRUMS

The MEINL Hand Drums are equipped with the finest hand selected goat heads. The scalloped frame guarantees a comfortable grip, which allows the fingers to apply pressure for a 'bending' note. Their light weight yet solid construction makes them perfect for unplugged situations and street percussion.



Sizes 10"
12"

Materials Rubber Wood (*Hevea brasiliensis* Muell.-Arg.)
Head: Hand selected goat heads

Colour AB = African Brown

HEADLINER® SERIES JINGLE STICKS

The MEINL Headliner® Series Jingle Sticks are a nice and affordable alternative to a tambourine. Nice sound effects are also achieved when used as a stick on a drum.

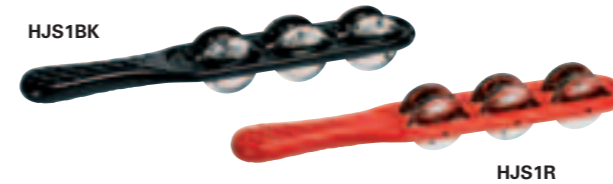

Materials Jingles: Nickelsilver plated steel
Frame: ABS

Colours BK = Black
R = Red

CLAVES DE LUXE

The MEINL Claves De Luxe are made from a superb, dense hardwood which delivers a cutting and bright tone. Due to their small size, they are portable and convenient but still enable a loud, solid rhythmic foundation on stage and in studio sessions.

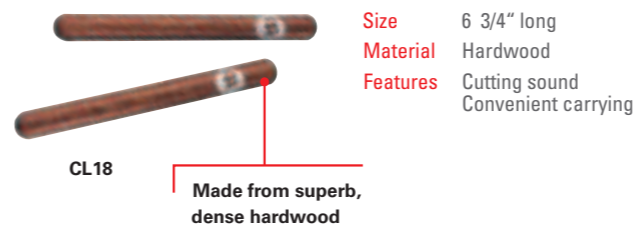

Size 6 3/4" long

Material Hardwood

Features Cutting sound
Convenient carrying

Made from superb, dense hardwood

WOOD CLAVES, CLASSIC

The MEINL Classic Wood Claves are the most common claves and produce the classic cutting sound. Both the clave and the striker have the same size.

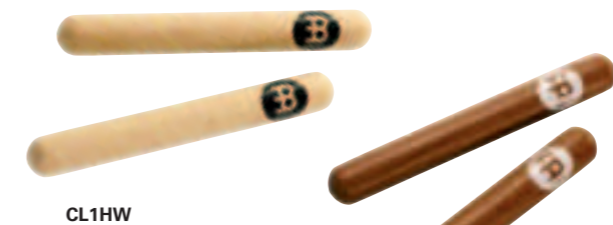

Materials HW = Hardwood
RW = Redwood

Feature Solid body



Materials HW = Hardwood
RW = Redwood

Features CL2 = Solid body
CL3 = Hollowed out body

JINGLE STICKS

The MEINL Jingle Sticks create many interesting sound possibilities.

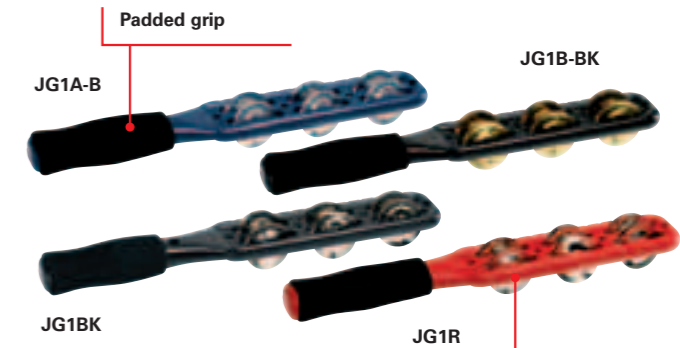

Jingles JG1 = Nickelsilver plated steel
JG1A = Aluminum
JG1B = Solid brass

Features Padded grip
Guiro style playing surface

FIBERGLASS CLAVES

The MEINL Fiberglass Claves produce the most penetrating, loud, and cutting sound of all. They are hand made from premium fiberglass which makes them nearly indestructible.

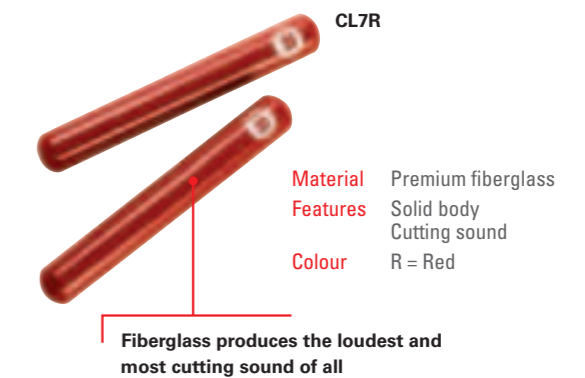

Material Premium fiberglass

Features Solid body
Cutting sound

Colour R = Red

Fiberglass produces the loudest and most cutting sound of all

WOOD CLAVES, AFRICAN

African Claves are slightly larger and have a lower fundamental pitch. Additionally, the resonating body is larger than the striker. Available in two different versions: Solid- and hollowed out body.

CHIMES

MEINL Chimes provide great tonal diversity and are available in a wide assortment of sounds. All MEINL Chimes are made from a premium anodized aluminum alloy, and a well balanced wooden bar. A durable nylon cord is used to attach them firmly together.

ARTIST SERIES

Luis Conte

"I wanted a wide spectrum!" comments Luis Conte. "The shorter bars deliver great high pitched sounds. I can get a full and bright chime sound from the medium and low pitched bars. They sound perfect especially in the studio."



CHIMES, 36 BARS

With bars made from hand polished aluminum, these chimes produce a sound that is clear, bright, and rich in volume and expression.



ROCK CHIMES, 33 BARS

The bars of MEINL Rock Chimes are thicker for a richer and more voluminous sound.



CHIMES, 66 BARS

The 66 bar chimes produce a rich and full sound. They cut through any band setting.



CHIMES, 33 BARS

The 33 bar chimes produce a very bright sound with a pronounced upper overtone spectrum. They are perfect for all live situations.

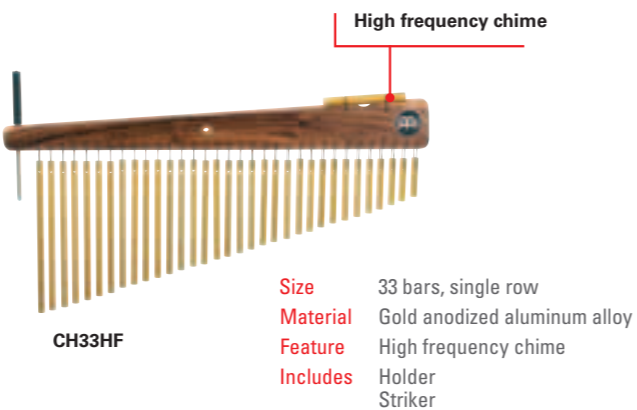

CHIMES, 27 BARS

The 27 bar chimes produce a full sound with a wide tonal spectrum. Ideal for smaller stages and club scenes.



STUDIO CHIMES, 27 BARS

The Studio Chimes feature slightly thinner bars for a full, rich and tasteful sound.



CHIMES, 12 BARS

The 12 bar chimes produce a beautiful, high pitched sound. Not too obtrusive, ideal for tasteful chime accents.



HEADLINER® SERIES CHIMES

The MEINL Headliner® Series Chimes are a great and affordable addition to any percussion set up! They are made from high quality materials and produce a full and warm chime sound.



CHIMES HOLDERS

These two differently sized MEINL holders comfortably place the chimes within a drum or percussion set up.

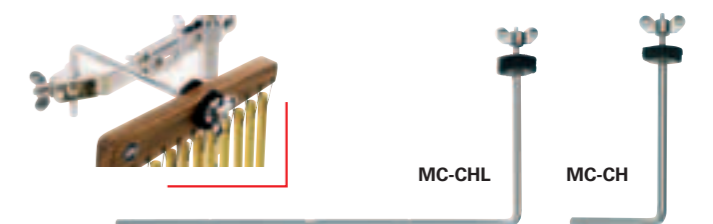

Sizes Regular, Large
Material Chrome plated steel
Features Knurled surface, Foam washer

PROFESSIONAL CHIMES BAG

The MEINL Chimes Bag fits all common chime models and is the perfect solution for transporting these valuable and fragile instruments. Inner velcro straps hold the instrument in place while two internal pockets secure them.

Material Heavy duty padded nylon
Features Stores up to 2 chimes, Carrying grip, Inner velcro straps, 2 internal pockets



2 internal pockets with inner velcro straps



HAND CHIMES

The three differently sized models of these hand chimes are tonally matched. They can easily be played by hand only and still produce a full and rich sound.

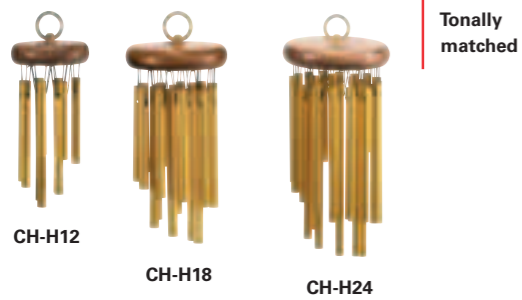

- Sizes** 12 bars
18 bars
24 bars
- Material** Gold anodized aluminum alloy

TRIANGLES

The solid brass triangles produce a nice sounding soft tone with a controlled sonic spectrum.



- Sizes** 4"
6"
8"
- Material** Solid brass
- Includes** Wooden holder with braided nylon cord
Metal beater

HANGING FINGER CYMBALS

Strung on a durable cord and made from a special bronze alloy, 14 unique finger cymbals produce a shimmering chorus effect.

- Size** 2 3/8" diameter
- Material** Special bronze alloy
- Features** Durable cord
Shimmering sound



PROFESSIONAL FINGER CYMBALS

Made from a special bronze alloy and attached with a durable cord, these professional finger cymbals are relatively heavy in weight producing a high pitched and cutting, pure ping sound.

- Size** 2 5/8" diameter
- Material** Special bronze alloy
- Features** Identical, high pitched sound
Durable cord



PEG CHIMES

The Peg Chimes are extremely high pitched. They are perfect for special accents.



- Size** 12 pegs
- Material** Gold plated steel

TRI TONE CHIMES

The three free floating bars create a very long sustain and are tonally matched.

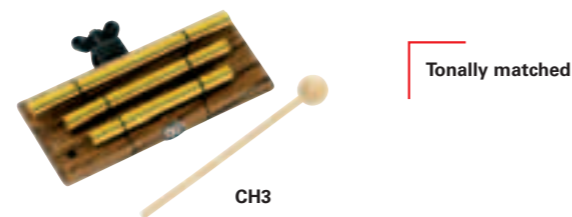

- Material** Gold anodized aluminum alloy
- Feature** Mountable on all common L-rods
- Includes** Wooden beater
Holder

TRIANGLE HOLDER

The MEINL Triangle Holder is a simple but effective way to place the triangle in the percussion set up.

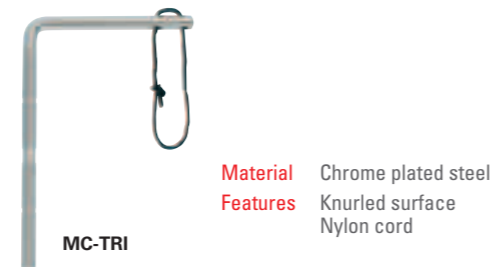

- Material** Chrome plated steel
- Features** Knurled surface
Nylon cord

FINGER CYMBALS

Connected with a durable rubber band, these finger cymbals are made from a special bronze alloy, ensuring a clear, delicate and pure sound. Measuring 2 3/8" in diameter, they are easy to hold and comfortable to play.

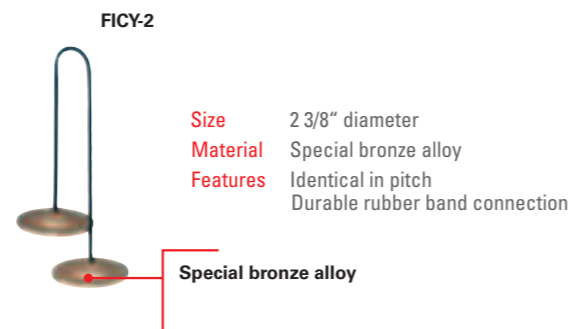

- Size** 2 3/8" diameter
- Material** Special bronze alloy
- Features** Identical in pitch
Durable rubber band connection

Special bronze alloy

TURBO CABASA (patent pending)

The MEINL Turbo Cabasa is a new innovation, with significantly more volume than normal cabasas. This comes from the eight sound ports in the resonating chamber (four on each end). The Turbo Cabasa brings the classic cabasa sound to a new level that will cut through any sonic environment.

- Size** Regular
- Materials** Steel chain and stainless steel cylinder
Wooden handle with padded soft grip
- Feature** 4 sound ports on each side for more volume
- Colour** BK = Black



CABASAS, WOOD

The MEINL Wood Cabasas are available in three different sizes and produce a clear and voluminous sound. Made from high quality components, they are very durable and long lasting.



- Sizes** Small
Regular
Large
- Materials** Steel chain and stainless steel cylinder
Wooden handle
- Colour** AM = Amber

CABASA HOLDER

This unique attachment holds the cabasa safe and ready to use. The padded surface prevents it from slipping.

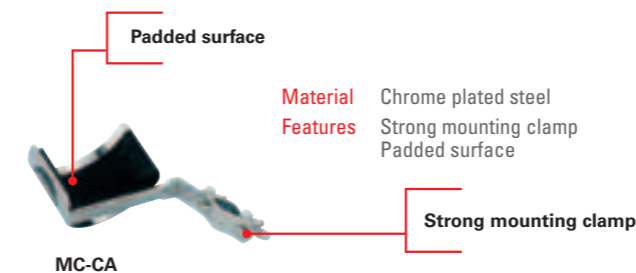

- Material** Chrome plated steel
- Features** Strong mounting clamp
Padded surface

THE ROAR

The MEINL Roar is available as a wood and as a fiberglass version. A rattling effect is achieved by striking the ball end against the palm of the hand.

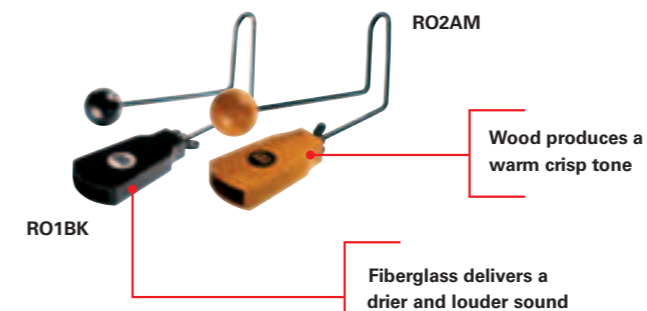

- Materials** Wood or premium fiberglass
- Feature** Solid construction

Wood produces a warm crisp tone

Fiberglass delivers a drier and louder sound

CABASA, WOOD WITH SOFT GRIP

The most common wood cabasa model is offered with a padded soft grip for a more comfortable playing feel.



- Size** Regular
- Materials** Steel chain and stainless steel cylinder
Wooden handle with padded soft grip
- Colour** CR = Cherry Red

THE NIGHT

When playing The Night, four solid steel balls hit a cylindrical metal rod in quick succession producing the unique sound of crickets.



- Materials** Solid steel balls and cylinder
Wooden body
- Feature** Ergonomically shaped handle
- Colour** AM = Amber

KOKIRIKO

The Kokiriko originated in Japan as a sound effect instrument. It produces a rattling effect which can be an almost silent rustling to an extremely loud chatter.

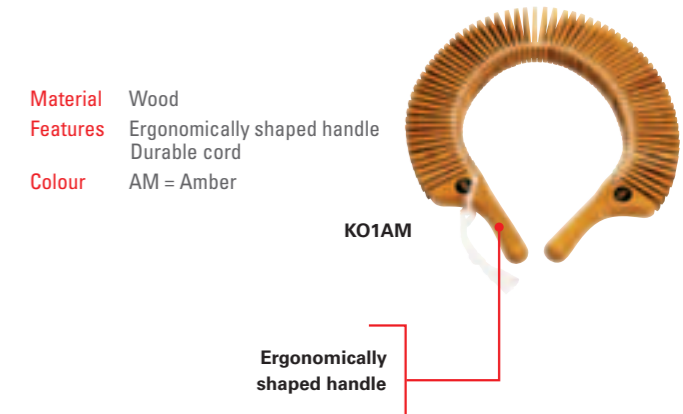

- Material** Wood
- Features** Ergonomically shaped handle
Durable cord
- Colour** AM = Amber

Ergonomically shaped handle

PERCUSSION BLOCK, HIGH PITCH

The MEINL Percussion Block is made to withstand even the hardest players. It delivers a cutting high pitched sound.



- MPE1BK**
- Material** PE
 - Features** High pitched sound
Durability
 - Includes** Mounting Clamp
 - Colour** BK = Black

PERCUSSION BLOCK, LOW PITCH

This MEINL Percussion Block delivers a low pitched sound and is easily mounted on any conventional L-rod.



- MPE2R**
- Material** PE
 - Features** Low pitched sound
Durability
 - Includes** Mounting Clamp
 - Colour** R = Red
- Easy mountable**

WOOD BLOCKS

The two versions of the MEINL Wood Blocks are tonally matched, highly durable and produce a voluminous sound with wood accents.

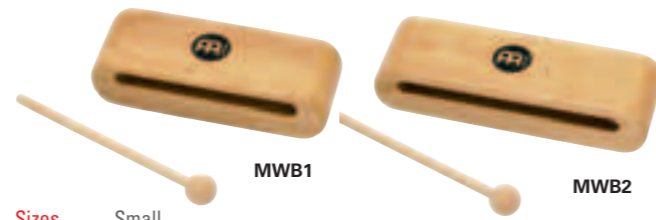

- MWB1**
- Sizes** Small
Large
 - Material** Rubber Wood
(*Hevea brasiliensis* Muell.-Arg.)
 - Feature** Rounded playing surface
 - Includes** Wooden beater
- MWB2**

WOOD BLOCK HOLDER

A special holder is available to include the MEINL Wood Blocks into any drum- or percussion set up. It can be fixed to any common L-Rod.

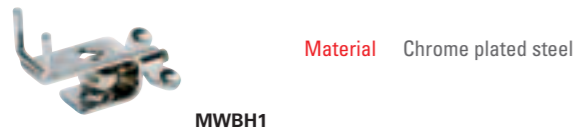

- MWBH1**
- Material** Chrome plated steel

FIBERGLASS GUIROS

The MEINL Fiberglass Guiros offer three different striking surfaces for enhanced sounds and rubber ringed grip holes.



- GU7BK**
- Material** Premium fiberglass
 - Features** Three striking surfaces
Rubber ringed grip holes
 - Includes** Plastic scraper
 - Colours** BK = Black
R = Red
- GU7R**

3 playing surfaces

WOOD GUIROS

The traditional MEINL Wood Guiros are available in two different versions and produce a warm and cutting sound.



- GU2AB-M**
- Material** Wood
 - Features** Three striking surfaces
Grip holes
 - Includes** Plastic scraper
 - Colour** AB-M = African Brown
 - Finish** Matt
- GU1AM**
- Material** Wood
 - Feature** Grip holes
 - Includes** Wooden scraper
 - Colour** AM = Amber

GUIRO HOLDER

The MEINL Guiro Holder firmly attaches to any common rod and holds the guiro securely in place while it is played.



- MC-GU**
- Material** Chrome plated steel
 - Feature** Rubber pads against scratching

PLASTIC GUIRO

The MEINL Plastic Guiro is precision molded from high strength plastic. It features three different striking surfaces and rubber ringed grip holes for maximum comfort and control.



- GU6BK**
- Material** High strength plastic
 - Features** Three striking surfaces
Rubber ringed grip holes
 - Includes** Plastic Scraper
 - Colour** BK = Black

SKIN MARACAS

The MEINL Skin Maracas are entirely made by hand and are offered in three different sizes for a wide sonic range. The two larger models sound especially full and dry, whereas the smaller sized version produces a very tight and high pitched sound.



- MSM4**
- Sizes** Midi
Traditional
Jumbo
 - Materials** Natural skin
Wooden handle
- MSM3**
- MSM2**

PLASTIC EGG SHAKERS

The MEINL Plastic Egg Shakers are preferred due to their smooth and crystal clear sound. These have applications in practically any musical setting.

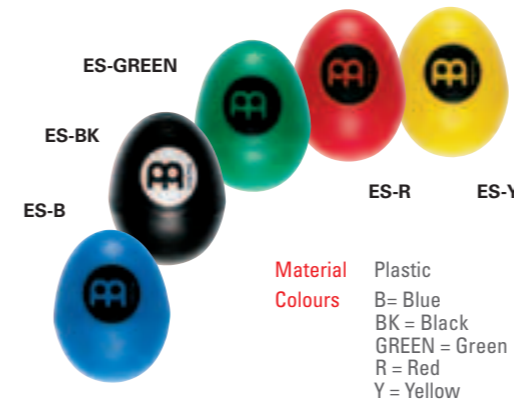

- ES-GREEN**
- ES-BK**
- ES-B**
- ES-R**
- ES-Y**
- Material** Plastic
 - Colours** B = Blue
BK = Black
GREEN = Green
R = Red
Y = Yellow

DOUBLE SHAKER

The MEINL Double Shaker is woven by hand. It offers two different sounds in one instrument.

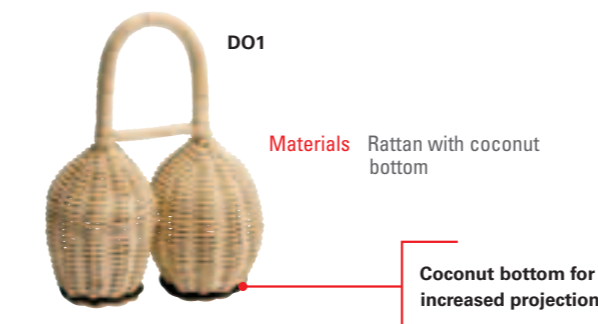

- DO1**
- Materials** Rattan with coconut bottom
 - Coconut bottom for increased projection**

PLASTIC MARACAS

The MEINL Plastic Maracas produce a loud and crisp sound. They are very durable and comfortable to play.



- PM2BK**
- Materials** Plastic
Wooden handle

WOOD MARACAS

The traditional MEINL Wood Maracas are available in both round and oval models. Both of these exhibit a traditional warm and rich sound.



- MWM1MC**
- Material** Wood
- MWM2AM**

WOOD EGG SHAKER

The MEINL Wood Egg Shaker is turned from wood and deliver a soft yet rich sound. It's perfect in situations which require clearly defined accents.



- ESW-J-BK**
- Size** Jumbo
 - Material** Wood
 - Colour** BK = Black

CAXIXIS/GANZA

The MEINL Caxixis/Ganza are woven by hand with a coconut bottom. Their sound is crystal clear, high pitched with a great projection.



- CAX1**
- CAX2**
- CAX3**
- Materials** Rattan with coconut bottom
- GA2**

RITUAL DRUMS

MEINL combines traditional instruments with modern technology and innovations. The range of Ritual Drums is a line of innovative instruments which originate in many different cultures from all around the world. MEINL's expertise in R&D helped in creating these authentic and high quality range of instruments which is outstanding in the percussion world.



Bill Summers, USA

RAMWONG

Ramwong is a Thai folk dance which evolved from Ramthone, a popular festive season in a certain region in Thailand. Ram means dance and Thone is a small drum.

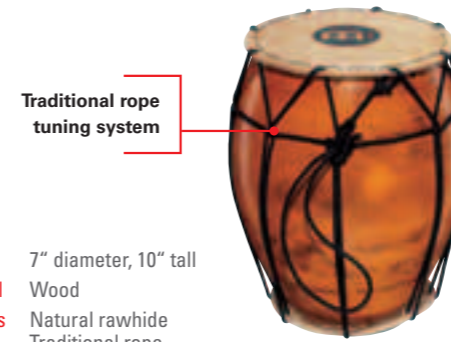

RAMWONG7

- Size** 7" diameter, 10" tall
- Material** Wood
- Features** Natural rawhide
Traditional rope tuning system

WOOD CONGUITAS

The Conguitas are a perfect addition to any percussion set up. They are made from high quality materials and produce a cutting and strong percussive tone which complements the congas in a harmonically supportive sound spectrum.

Hand selected buffalo head



HCG89NT

Heavy duty stand can be tilted



- Sizes** 8" & 9"
- Material** Rubber Wood
(*Hevea brasiliensis* Muell.-Arg.)
- Features** 8 mm strong tuning lugs
Original MEINL style tuning brackets
Traditional rims
Black powder coated hardware
Hand selected buffalo heads

- Includes** Height adjustable tilting
double braced tripod stand
Tuning key
Wrench
- Colour** NT = Natural
- Finish** Hi Gloss

TAMBORA

NEW

The rhythm of the Merengue has its roots in the Dominican Republic where the use of a Tambora drum is essential in creating this style of music.



MTA1SNT-M

Nylon strap

- Size** 11"
- Material** Rubber Wood
(*Hevea brasiliensis* Muell.-Arg.)
- Features** True Skin Buffalo Heads
Black powder coated hardware
- Includes** Nylon strap
Wooden beaters
Tuning key
- Colour** SNT-M = Super Natural
- Finish** Matt

BATAS

The MEINL Batas are made from premium fiberglass for more durability, lighter weight and comfortable playing, and have a traditionally authentic sound.

Hand selected buffalo head



BA1BK

BA3BK

BA2BK

- Sizes** Okonkolo 5 1/4" & 8"
Itotele 5 3/4" & 8 3/4"
Iya 6 3/4" & 12"
- Material** Premium fiberglass
- Features** Hand selected buffalo heads
Traditional TTR-Rims
- Includes** Nylon strap
Tuning key
- Colour** BK = Black

CABASA, FIBERGLASS

The shape and function of the MEINL Fiberglass Cabasa equals a traditional gourd calabash. The MEINL fiberglass version however offers positive stability and dynamic sound quality.

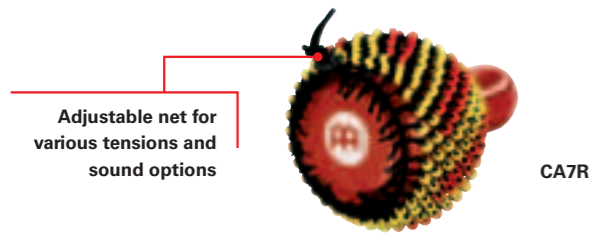

Material Premium fiberglass
Colour R = Red

SHEKERE, JUMBO SIZE

MEINL's Jumbo Size Shekere is hand made from premium fiberglass and fitted with a net of synthetic pearls.

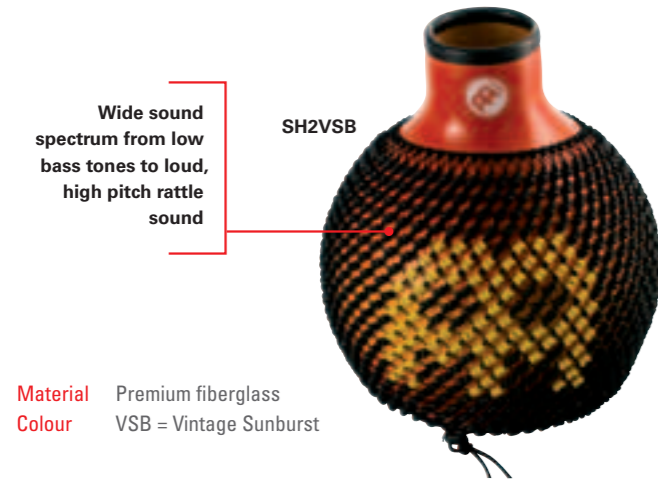

Material Premium fiberglass
Colour VSB = Vintage Sunburst

TALKING DRUM

The Talking Drum has its origin in West Africa. The traditional technique involves squeezing the tuning ropes while striking the head with a small bent wooden mallet.

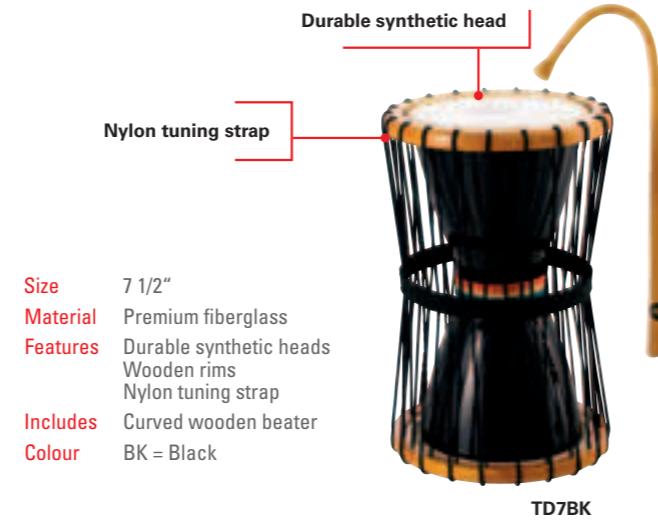

Size 7 1/2"
Material Premium fiberglass
Features Durable synthetic heads
Wooden rims
Nylon tuning strap
Includes Curved wooden beater
Colour BK = Black

SHEKERE

The MEINL Shekere is handmade from premium fiberglass and fitted with a net of synthetic pearls. It delivers a rich, full sound and unlike gourd shekeres it is nearly unbreakable.



Material Premium fiberglass
Colour BK = Black

BIRDS/WATERFALL

NEW

The MEINL Birds and Waterfall made out of Rubber Wood (*Hevea brasiliensis* Muell.-Arg.) enable a brighter timbre and a more penetrating sound.



BI1NT WA1NT

BIRDS/WATERFALL

The MEINL Birds and Waterfall realistically imitate the sound of a flock of birds or a rippling waterfall. By using fiberglass a bright sound is produced, the dynamic range is increased and an optimum durability is realized.



BI7RY WA7BK

WAH-WAH TUBES

The MEINL Wah-Wah Tube is a tubular effect instrument that delivers smooth, bell-like tones with an incredible sustain.

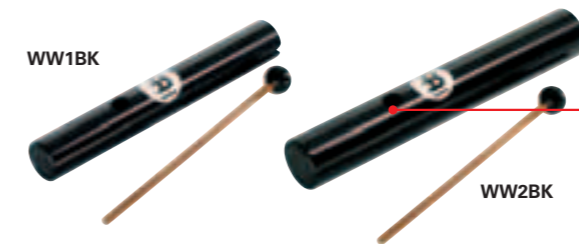

Sizes Small (high pitch)
Large (low pitch)
Material Aluminum
Includes Rubber mallet
Colour BK = Black

RAINMAKER

The MEINL Rainmaker is uniquely different. Due to the circular construction, it can be mounted on a cymbal stand and by simply turning the instrument a drizzle can immediately change into the sound of a monsoon.



BERIMBAU

The MEINL Berimbau is another traditional African instrument which is very prevalent in Brazil and other countries of South America. Three parts are involved: The metal plate, the small caxixi, and the stick.

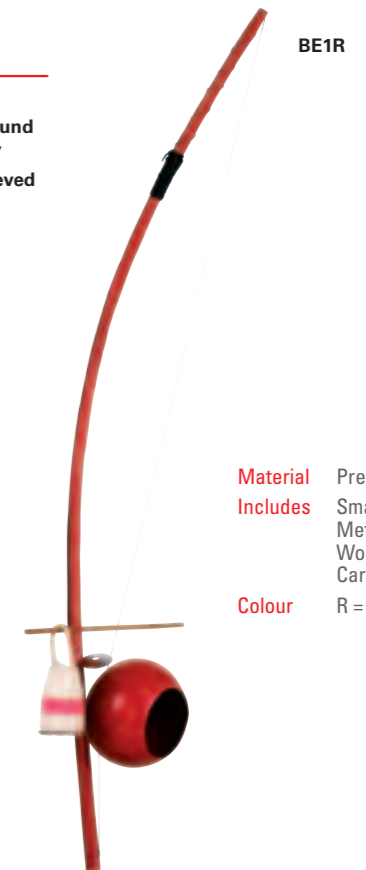

IBO DRUMS

The MEINL Ibo Drums perfectly combine tradition with modern innovation. "Ibo" is the Nigerian name for "pottery" where these unique drums originate. They all have a wide spectrum of sounds, are easy to play and offer many great features.

FIBERGLASS IBO DRUM

The MEINL Fiberglass Ibo Drum has a wide variety of different sounds and the fiberglass body makes it nearly unbreakable.



- Size** Large
- Material** Premium fiberglass
- Features** Built in microphone hole
Resistant shell construction
- Includes** Foam padded base
- Colour** BKR = Black/Red

ID1BKR

FIBERGLASS IBO DRUM, LONG NECK

The MEINL Fiberglass Ibo Drum has a wide variety of different sounds and the fiberglass body makes it nearly unbreakable.



- Size** Long neck
- Material** Premium fiberglass
- Features** Built in microphone hole
Resistant shell construction
- Includes** Foam padded base
- Colour** BKR = Black/Red

ID2BKR

FIBERGLASS TRI SOUND IBO DRUM

The MEINL Tri Sound Ibo Drum features an additional rawhide playing surface and an extra thin bottom for enhanced sound.

- Size** Large
- Material** Premium fiberglass
- Features** Rawhide playing surface
Built in microphone hole
Resistant shell construction
- Includes** Foam padded base
- Colour** GO = Gold Ornament



ID3GO

FIBERGLASS TRI SOUND IBO DRUM

The MEINL Tri Sound Ibo Drum features an additional fiberglass playing surface and an extra thin bottom for enhanced sound.



- Size** Large
- Material** Premium fiberglass
- Features** Extra fiberglass playing surface
Built in microphone hole
Resistant shell construction
- Includes** Foam padded base
- Colour** BKO = Black Ornament

ID4BKO

PROFESSIONAL IBO BAGS

The MEINL Ibo Bag fits all common clay drum models and is the perfect solution for transporting these valuable and fragile instruments. Its heavy duty padded outside walls store it securely and prevents damage.



- Sizes** Small (9 3/4" W x 13 1/3" H x 9 3/4" D)
Medium (11" W x 14 1/2" H x 11" D)
- Material** Heavy duty padded nylon
- Includes** Padded shoulder strap
Carrying grip
External pocket

MIB-S

MIB-M

WOOD IBO DRUM

This unique instrument is another true MEINL innovation. It features a wooden body for a wide sonic range.

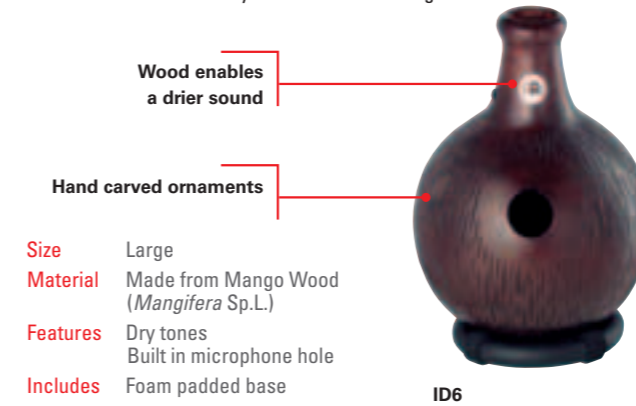

- Size** Large
- Material** Made from Mango Wood (*Mangifera Sp.L.*)
- Features** Dry tones
Built in microphone hole
- Includes** Foam padded base

ID6

CERAMIC IBO DRUM

The special feature of this MEINL Ceramic Ibo Drum is the fiberglass bottom for extra sound options.



- Size** Large
- Material** Ceramic
- Features** Fiberglass playing surface
Built in microphone hole
- Includes** Foam padded base
- Colour** RB = Red/Brown

ID8RB

PROFESSIONAL IBO STAND

The MEINL Ibo Stand was designed to enable playing an Ibo Drum in ways other than simply being placed in one's lap, such as standing up or incorporating it into a percussion set up. It can be angled and is fully height adjustable.

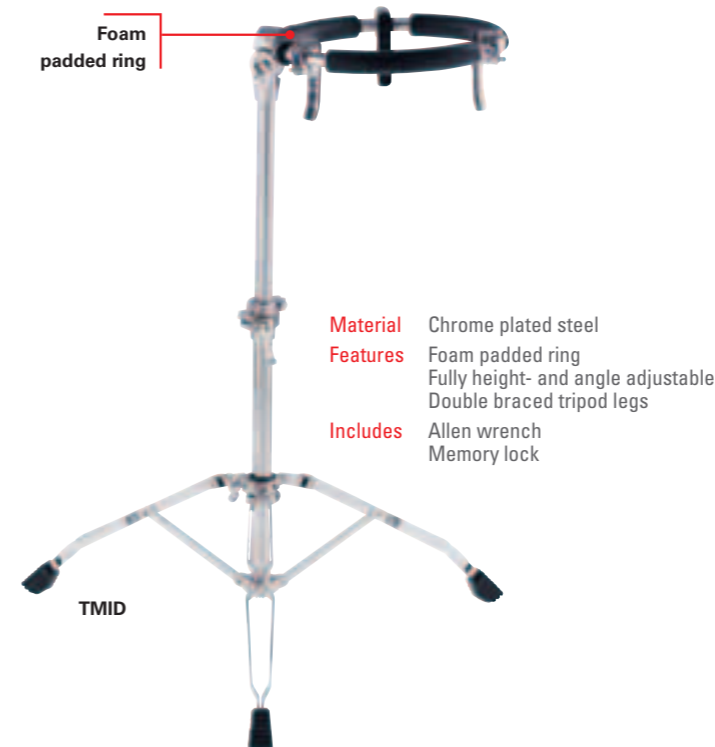

- Material** Chrome plated steel
- Features** Foam padded ring
Fully height- and angle adjustable
Double braced tripod legs
- Includes** Allen wrench
Memory lock

TMID

IBO HOLDER

The MEINL Ibo Holder securely supports most common ibo drums in a comfortable position while enabling you to play the ibo with both hands, or with one hand free for other instruments.



- Material** Black powder coated steel
- Includes** Allen wrench
Foam padded base

TMIH

DOUMBEKS

MEINL Doumbeks come from the same geographical points of origin as the darbukas, and are a favourite choice of drum for percussionists world-wide. Our doumbeks feature an ergonomic, Egyptian-style rounded rim with internal tuning lugs and a synthetic head. The bearing edge is carefully machined to assure consistent tuning. The doumbeks are well suited for fast finger-roll techniques and have a strong projection. The shells are constructed from various materials, each offering a wide range of timbres, weights and visual aesthetics.



Tercanli Tuncay, Turkey

Beatrix Fini, Italy

Davut Avutan, Turkey

COPPER DOUMBEK, HAND ENGRAVED

The copper shell of this MEINL Doumbek is hand engraved for a stunning look. A very traditionally looking and sounding instrument.

- Size** 8 1/2" x 17 1/8"
- Material** Copper
- Features** Synthetic head
Hand engraved shell
- Includes** Carrying bag
Spare head
Tuning key



HE-3012

Hand engraved shell

ALUMINUM DOUMBEK, HAND HAMMERED

The aluminum shell of this MEINL Doumbek is completely hand hammered for a most appealing look.

- Size** 8 1/2" x 17 1/8"
- Material** Aluminum
- Features** Synthetic head
Hand hammered shell
- Includes** Carrying bag
Spare head
Tuning key



HE-3030

Hand hammered shell

ALUMINUM DOUMBEK, WOOD COVERED

The shell of this MEINL Doumbek is made from aluminum and is completely covered with a layer of the finest wood. Combined with its synthetic head, it ensures a warm and smooth tone with lots of low end and less ringing highs.

- Size** 8 1/2" x 17 1/8"
- Material** Aluminum
- Features** Synthetic head
Wood covered shell
- Includes** Carrying bag
Spare head
Tuning key



HE-3400

Wood covered shell

ALUMINUM DOUMBEKS

Hand made entirely of aluminum, the MEINL Doumbek is outstanding in sound and quality reaching from resonant lows to ringing highs. Available as black vinyl covered or copper finished versions.



HE-3000

HE-3020

Black vinyl covered

Copper finish

- Size** 8 1/2" x 17 1/8"
- Material** Aluminum
- Feature** Synthetic heads
- Includes** Carrying bag
Spare head
Tuning key

PROFESSIONAL DOUMBEK STAND

The MEINL Doumbek Stand was designed to enable incorporating a Doumbek into a percussion- or drum set up. An adjustable, foam padded ring holds the Doumbek Drum firmly and prevents it from sliding or falling down. It can be angled and is fully height adjustable.

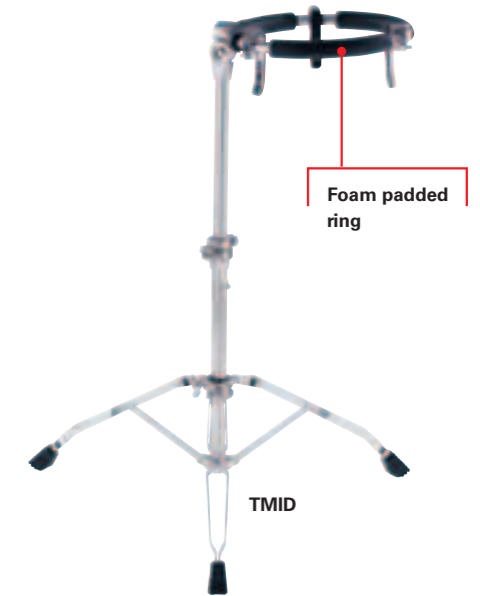

Foam padded ring

TMID

- Material** Chrome plated steel
- Features** Foam padded ring
Fully height- and angle adjustable
Double braced tripod legs
- Includes** Allen wrench
Memory lock

PROFESSIONAL DOUMBEK BAG

The MEINL Doumbek Bag is made from heavy duty padded nylon with reinforced stitching and is equipped with a double-slide zipper, a padded shoulder strap, and a carrying grip. It protects your instruments and provides hassle free transportation.



Carrying grip

MDOB

Additional upright zipper

Padded shoulder strap

- Material** Heavy duty padded nylon
- Features** Double-slide zipper
Additional upright zipper
Padded shoulder strap
Carrying grip
External pocket





DARBUKAS

MEINL Darbukas are made in the tradition of the original, esoteric goblet-shaped drums found in music from Eastern Europe, the Middle East and Southern Asia. Our darbukas are constructed from thin shells in various metals, each metal giving the different models their special timbre. The head is secured and tuned with external rings set close to the shell, in the Turkish-style. Light yet powerful, the darbukas have a deep full bass. They are well suited for high-pitched snapping sounds as well as a wide range of articulated "dum" and "tak" strokes.

ALUMINUM DARBUKAS, PLAIN

These Turkish style MEINL Darbukas feature fat lows and ringing highs with a wide range between.



Sizes HE-100 = 5 1/3" x 9 1/4"
HE-101 = 5 7/8" x 11"
HE-102 = 6 1/2" x 12 3/4"
HE-103 = 7 1/4" x 13 1/3"
HE-104 = 8" x 14 1/2"

Material Aluminum
Feature Synthetic heads
Includes Tuning key

ALUMINUM DARBUKAS, HAND HAMMERED

These MEINL Turkish style Darbukas have a beautifully hand hammered shell. They offer resonant lows and ringing highs with a wide range between.

Sizes HE-113 = 7 1/4" x 13 1/3"
HE-114 = 8" x 14 1/2"

Material Aluminum
Features Synthetic heads
Hand hammered shells
Includes Tuning key

ALUMINUM JINGLE DARBUKAS, HAND HAMMERED

These MEINL Aluminum Darbukas feature a beautifully hand hammered shell and built in jingles which adds a nice rattling effect and enhances their sound spectrum tremendously.



Sizes HE-314 = 8" x 14 1/2"
HE-315 = 8 1/4" x 16"

Material Aluminum

Features Built in jingles
Synthetic heads
Hand hammered shells
Includes Tuning key

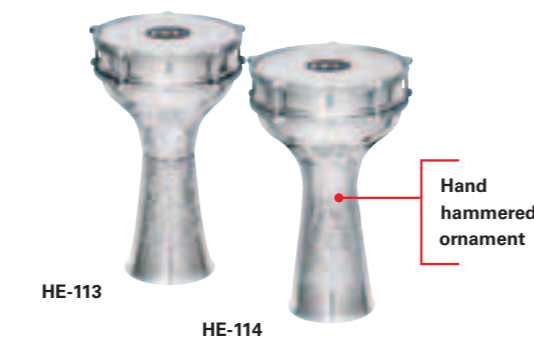

COPPER DARBUKAS, BRASS PLATED, HAND HAMMERED

These unique instruments are made entirely of copper with a brass plated- and hand hammered shell. Strong high tones with resonant lows.

Sizes HE-214 = 7 1/2" x 14 3/4"
HE-215 = 7 7/8" x 15 1/2"

Material Copper
Features Synthetic heads
Hand hammered shells
Includes Carrying bag
Spare head
Tuning key

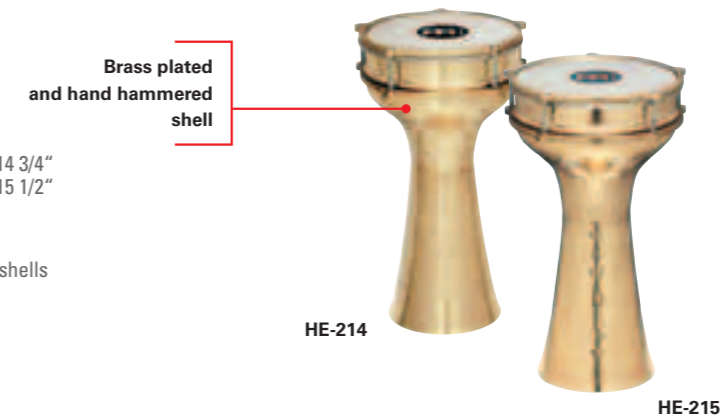

COPPER DARBUKAS, HAND ENGRAVED

The beautifully hand engraved shell of this copper darbuka is outstanding in sound and look!

Sizes HE-204 = 7 1/2" x 14 3/4"
HE-205 = 7 7/8" x 15 1/2"

Material Copper
Features Natural rawhides
Hand engraved shells
Includes Carrying bag
Spare head
Tuning key



PROFESSIONAL DARBUKA BAG

The MEINL Darbuka Bag is made from heavy duty padded nylon with reinforced stitching and is equipped with a double-slide zipper, a padded shoulder strap, and a carrying grip. It protects your instruments and provides hassle free transportation.



HEADLINER® SERIES DANCING DRUMS

The MEINL Headliner® Series Dancing Drums are the perfect instruments for educational or street percussion. They are made from high quality materials and produce great sounds. A great gift idea as well.

FIBERGLASS DANCING CONGA



HC301R

- Size** 8 1/2" x 24" tall
- Material** Premium fiberglass
- Features** 7 mm strong tuning lugs
2.2 mm rounded rim
Black powder coated hardware
- Includes** Nylon strap
Tuning key
- Colour** R = Red

FIBERGLASS DANCING DJEMBE



HDJ400R

- Size** 12" x 22 3/4" tall
- Material** Premium fiberglass
- Features** 7 mm strong tuning lugs
2.2 mm rounded rim
Black powder coated hardware
- Includes** Nylon strap
Tuning key
- Colour** R = Red

FIBERGLASS FAMILY DRUMS



HFDD1BK

HFDD2R

HFDD3Y

- Sizes** HFDD1BK = 8 3/4", tall 13 1/2"
HFDD2R = 8", tall 11 1/4"
HFDD3Y = 7 1/2", tall 9 3/4"
- Material** Premium fiberglass
- Features** 8 mm strong tuning lugs
Traditional rim
Black powder coated hardware
- Includes** Nylon strap
Tuning key
- Colours** BK = Black
R = Red
Y = Yellow

FIBERGLASS MINI DANCING DJEMBES



HDJ200Y

HDJ200B

- Size** 8" x 14 1/3" tall
- Material** Premium fiberglass
- Features** Traditional rim
Black powder coated hardware
Floatune Tuning System
- Includes** Nylon strap
Tuning key
- Colours** B = Blue
Y = Yellow

GLOW IN THE DARK CONGA AND BONGO

The unique "Glow In The Dark" finish is an original MEINL innovation and one-of-a-kind in today's percussion world. By applying a fluorescent layer of lacquer, the drums actually start to "Glow In The Dark." This results in an awesome visual effect on stage, especially in small clubs with dim lights. This finish is by far the most in demand look of today's Live Dance and Techno Scene.

WOOD CONGA SET



HC512GLOW

- Sizes** 11" & 12" Conga Set
28" tall
- Material** Rubber Wood (*Hevea brasiliensis* Muell.-Arg.)
- Features** Hand selected buffalo heads
8 mm strong tuning lugs
Original MEINL style tuning brackets
2 mm rounded rims
Black powder coated hardware

WOOD BONGO



HB100GLOW

- Sizes** 6 3/4" Macho & 8" Hembra
- Material** Rubber Wood (*Hevea brasiliensis* Muell.-Arg.)
- Features** Hand selected buffalo heads
8 mm strong tuning lugs
2 mm rounded rims
Black powder coated hardware
Interior backing plates
- Includes** Tuning key
- Colour** GLOW = Glow In The Dark

Hand selected buffalo head

2 mm rounded rim

Awesome visual "Glow In The Dark" effect

IMPROVED

- Includes** Height adjustable basket stands with quick set up system
Tuning key
- Colour** GLOW = Glow In The Dark



HEADLINER® SERIES DANCING DRUMS, GLOW IN THE DARK

DANCING CONGA, DANCING DJEMBE, MINI DANCING DJEMBES, FAMILY DRUMS
WOOD CONGA SET, WOOD BONGO



"HERE IS ENOUGH SPACE FOR ALL THE INSTRUMENTS I NEED AT MY GIGS!"

ROLAND PEIL about the MEINL PERCUSSION WORKSTATION

Finally an ingenious percussion Workstation that holds up and has enough space for all my wonderful toys!

This Workstation features one large and two small attachable and padded fiberglass tables for placing all kinds of hand percussion. The big legs make this tool absolutely steady, no matter how much fun we have on stage! The angle adjustable top bar with the different rods and hooks allows me to mount all kinds of beautiful toys such as tambourines, blocks, bells, chimes, finger cymbals, caxixis, rainmakers and much more ...

With the combination of other MEINL hardware I can adjust my Workstation for any need at any gig. Other great tools are the various rods. With their help, I am able to bring every instrument into perfect position. The MC-R3 is suitable for shortening the distance between the instrument and the player. Equally useful is the MC-R2 that brings my cow bells into a slanted position. Another good idea is the multi clamps. They are easy to mount on any stand that comes along and can be equipped with rods for mounting more instruments.

Definitely one for the road!

PERCUSSION WORKSTATION

When it comes to ease of access and playability, the MEINL Percussion Workstation is the ultimate solution. Made with great attention to detail, the MEINL Percussion Workstation has been designed to be customized by the player's demand. Depending on any given space situation, it can be expanded or reduced to fit the individual needs.

With the majority of its colour being black, the MEINL Percussion Workstation will blend in nicely with the overall stage design and won't interfere with the lighting- and design engineers' concepts.

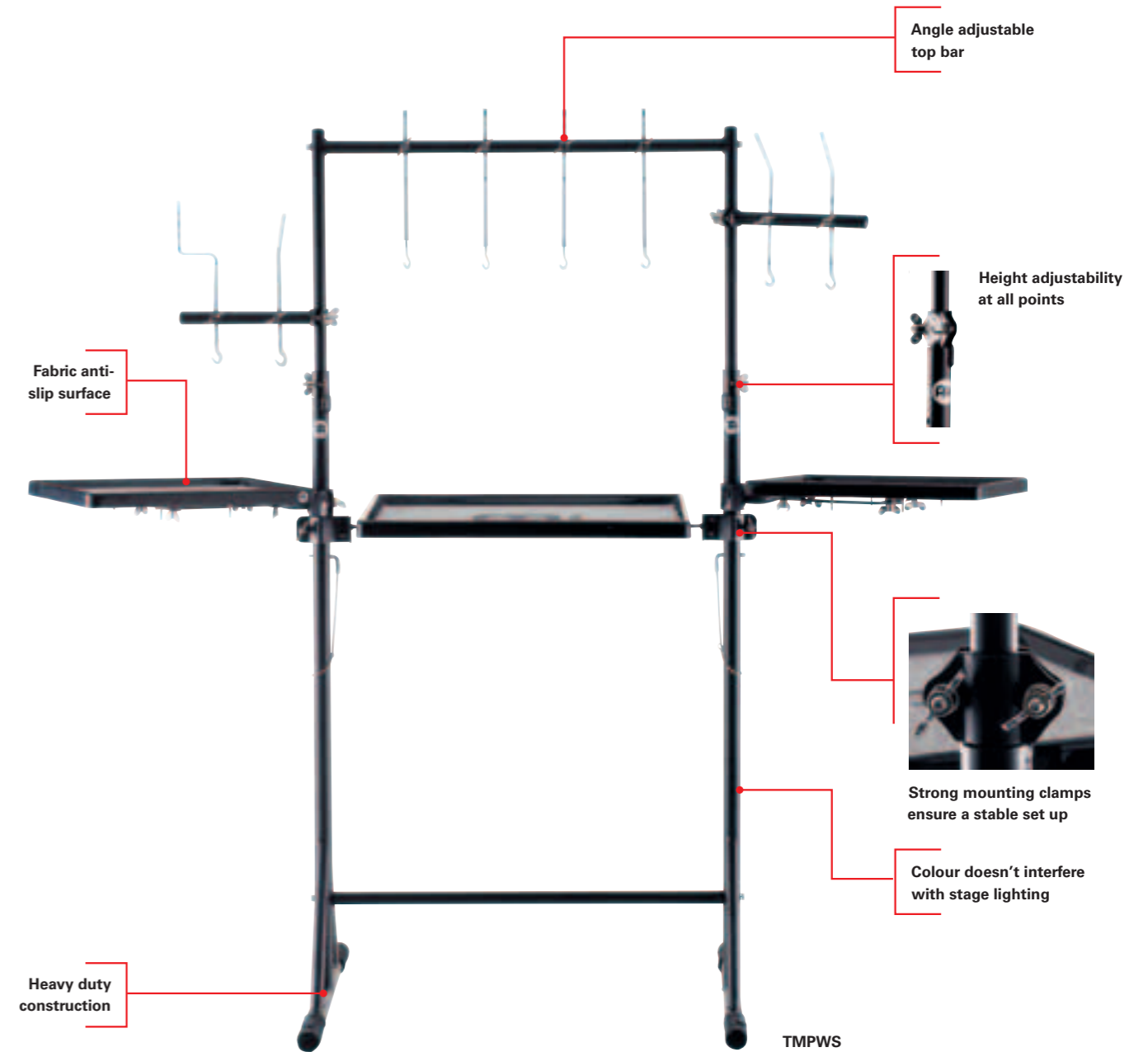

Material Black powder coated steel

Features Fully height adjustable
Angle adjustable top bar
Fabric anti-slip surface
Heavy duty construction
Infinitely expandable
Fabric anti-slip surfaces
Colour doesn't interfere with stage lighting

Includes 1 pc 22" x 24" padded fiberglass percussion table
2 pcs 18" x 12" padded fiberglass percussion tables (attachable)
1 pc 30" vertical bar
2 pcs 15" vertical bars (attachable)
4 pcs straight rods with hook
3 pcs angled rods with hook
1 pc Z-shaped rod with hook

PERCUSSION TABLES

The MEINL Percussion Tables are made from durable fiberglass and offer enough room for all common hand percussion instruments. It can be attached to all common stands. Through its innovative design the angle of the table can be adjusted.

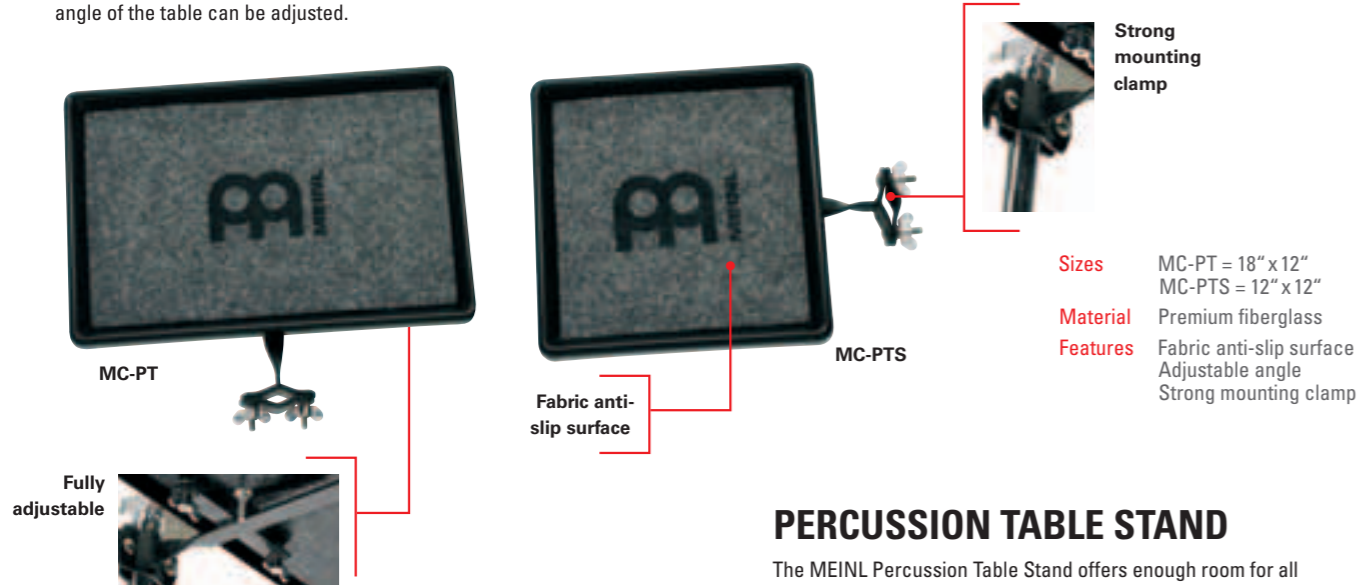

PERCUSSION TABLE STAND

The MEINL Percussion Table Stand offers enough room for all common hand percussion instruments. It is fully height adjustable and has a fabric anti-slip surface.

PERCUSSION STAND

The MEINL Percussion Stand is a universal device which offers a variety of set up solutions for both drummers and percussionists. It is fully height adjustable and features both quick locks and memory locks for a quick set up.

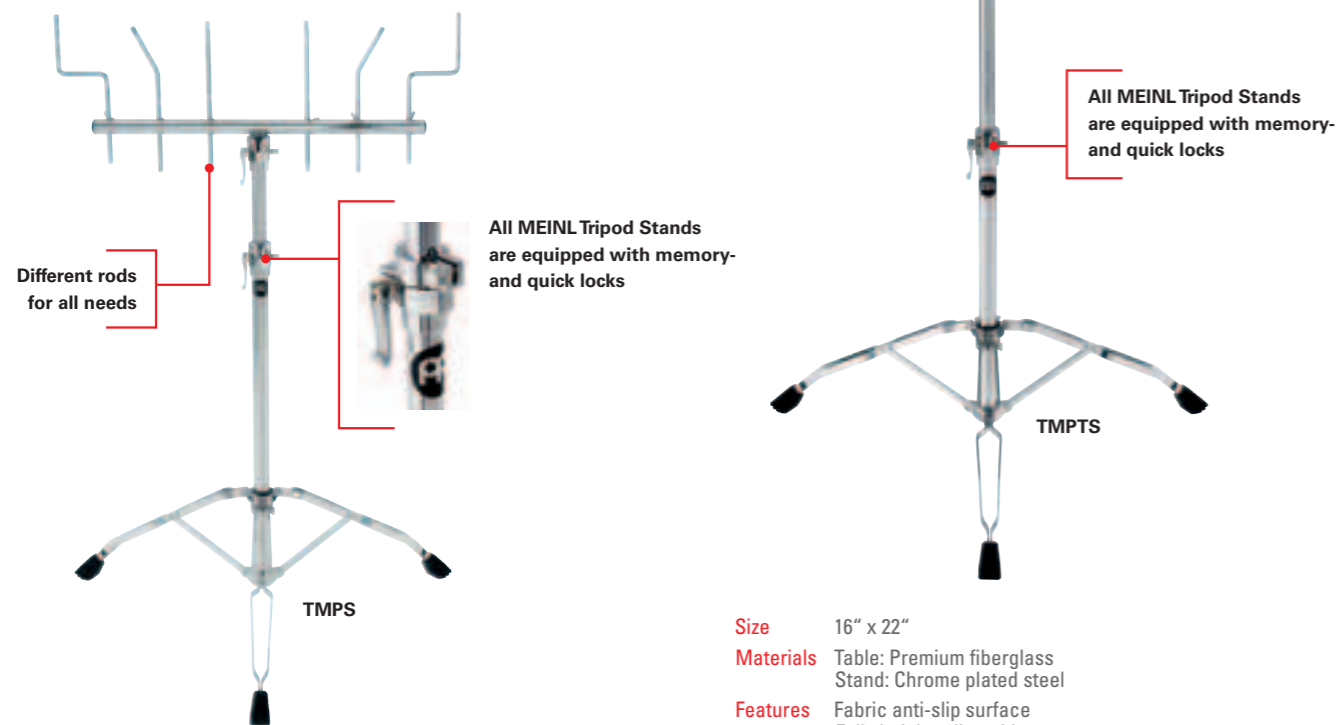

- Material** Chrome plated steel
- Features** Height adjustable
Double braced tripod legs
- Includes** Allen wrench
Memory locks
2 straight rods
2 angled rods
2 Z-shaped rods

ORIGINAL MEINL HARDWARE

A professional mounting system requires stability and flexibility. The Original MEINL Hardware features the highest quality workmanship to provide a large variety of set up solutions for both percussionists and drummers alike. A system of well thought out clamps, holders, rods, and attachments for literally any set up or space situation.

MULTI CLAMP, ONE MOUNT

The MEINL Multi Clamp easily attaches to any common stand. Its unique feature is the length adjustability to fit any given space situation. It holds one rod.

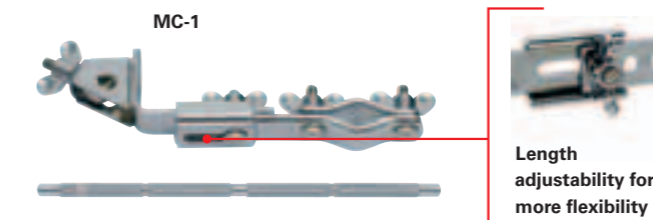

- Material** Chrome plated steel
- Features** Length adjustable
Strong mounting clamp
- Includes** Straight rod

CLAMP

The MEINL Percussion Clamp attaches to the lug of a conga, bongo, or djembe for mounting an additional cowbell, block, or tambourine.

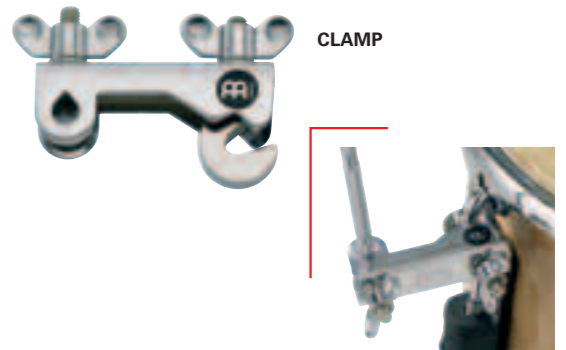

- Material** Chrome plated steel
- Feature** Compact and solid design

MULTI CLAMP, TWO MOUNTS

The MEINL Multi Clamp easily attaches to any common stand. Its unique feature is the length adjustability to fit any given space situation. It holds two rods.

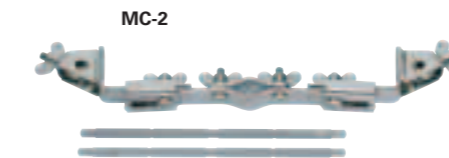

- Material** Chrome plated steel
- Features** Length adjustable
Strong mounting clamp
- Includes** 2 straight rods

MOUNTING BAR, 6 PCS.

The MEINL Mounting Bar can easily be attached to any stand. It's ideal for expanding your percussion or drum set up.

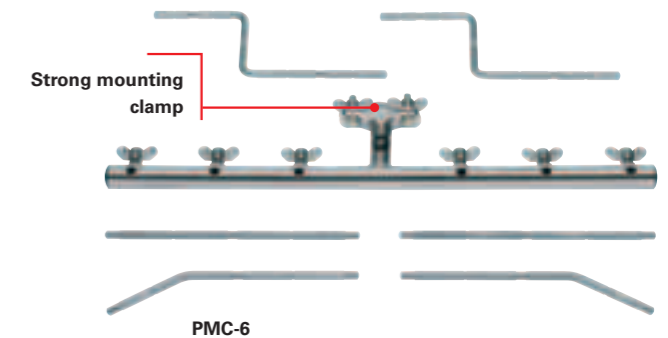

- Material** Chrome plated steel
- Includes** 2 straight rods
2 angled rods
2 Z-shaped rods

MULTI CLAMP, FOUR MOUNTS

The MEINL Multi Clamp easily attaches to any common stand. Its unique feature is the length adjustability to fit any given space situation. It holds four rods.

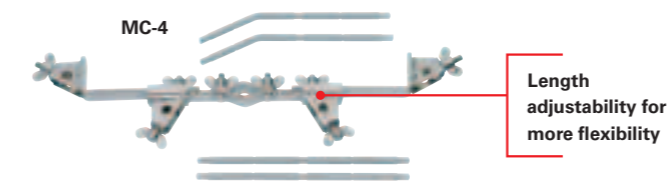

- Material** Chrome plated steel
- Features** Length adjustable
Strong mounting clamp
- Includes** 2 straight rods
2 angled rods

RODS

A variety of differently shaped rods can hold several mountable hand percussion instruments.



- Shapes** Angled rod
Straight rod
Z-shaped rod
- Material** Chrome plated steel
- Features** Knurled surface

CANDELA PERCUSSION CYMBALS

The MEINL Candela Series of Percussion Cymbals have been designed to meet the specific requirements of today's percussionists. They are extremely thin cymbals which produce soft, exotic tones, are tonally matched and respond even at lower volumes.

PERCUSSION CRASHES

The crashes are thin, tonally matched cymbals which can be played by hand or hit with a stick. They respond fast and decay quickly.

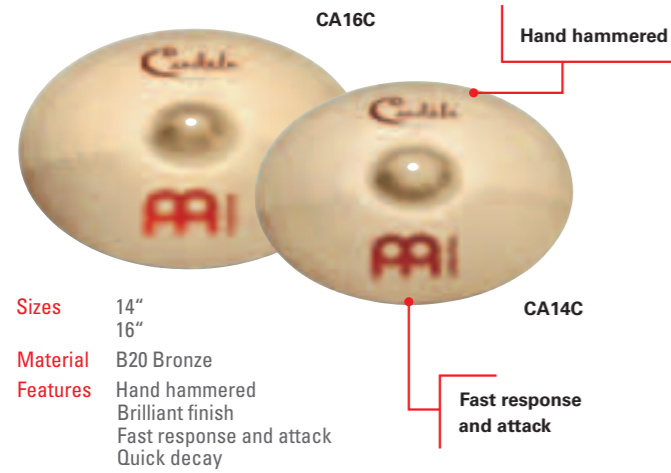

- Sizes** 14"
16"
- Material** B20 Bronze
- Features** Hand hammered
Brilliant finish
Fast response and attack
Quick decay

PERCUSSION SPLASH

The percussion splash is an extremely thin, quick sounding cymbal – perfect for fast percussive accents.

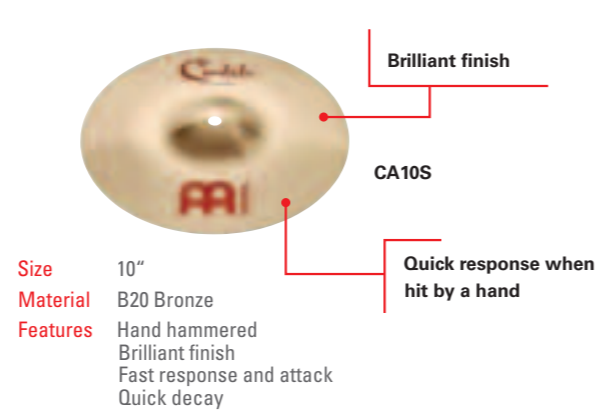

- Size** 10"
- Material** B20 Bronze
- Features** Hand hammered
Brilliant finish
Fast response and attack
Quick decay

TIMBALE CRASH/RIDE

It's the perfect cymbal for timbale playing. It has a loud, penetrating bell and a full, warm crash sound.



- Size** 18"
- Material** B20 Bronze
- Features** Hand hammered
Brilliant finish
Cutting bell sound
Great crash sound

TAM TAMS

The MEINL Percussion Tam Tams create a voluminous dark sound with an extremely long sustain.

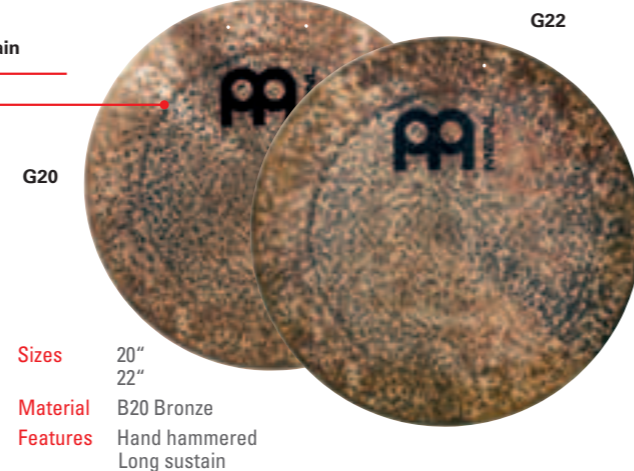

- Sizes** 20"
22"
- Material** B20 Bronze
- Features** Hand hammered
Long sustain

PERCUSSION JINGLE BELL

A great cymbal with an exotic sound. Six pairs of jingles attached to this cymbal produce a rattling effect.

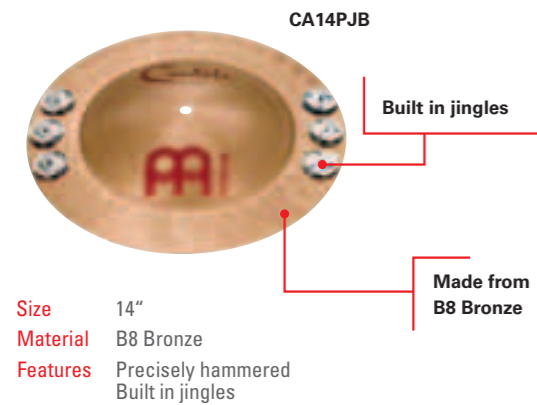

- Size** 14"
- Material** B8 Bronze
- Features** Precisely hammered
Built in jingles

TAM TAM STAND

The MEINL Tam Tam Stand holds all common tam tams up to 22" diameter.

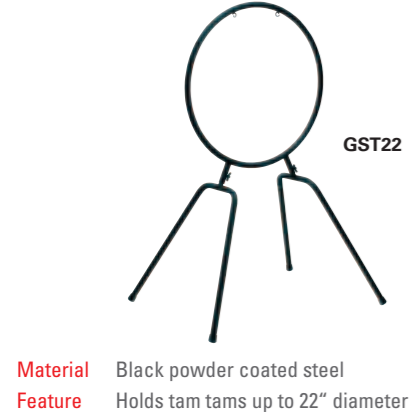

- Material** Black powder coated steel
- Feature** Holds tam tams up to 22" diameter

CYMBAL TROLLEY

The MEINL Cymbal Trolley holds cymbals up to 22" in diameter and has an external compartment for cymbals up to 14" in diameter. The whole bag is mounted on two stable wheels and has a length adjustable grip that allows convenient transportation of those heavy instruments.

- Size** 22"
- Materials** Bag: Heavy duty padded nylon
Wheels: Hard plastic
- Features** External cymbal compartment
External accessory compartment
Internal padded cymbal dividers
Stable wheels
Length adjustable grip



CYMBAL BAGS

The MEINL Cymbal Bags are available in 22" and 24" diameter. An external compartment which holds cymbals up to 14" allows a comfortable weight balance when packed.



- Sizes** 22"
24"
- Material** Heavy duty padded nylon
- Features** External compartment
Padded dividing pads
Padded shoulder strap
Carrying grip

STICK BAG

The MEINL Stick Bag offers four spacious sections for drumsticks and a separate compartment for drum keys, small tools and other valuables.



- Material** Heavy duty padded nylon
- Features** External pocket
Shoulder strap
Extension straps

DRUMSTICK HOLDER

The MEINL Drumstick Holder firmly attaches to any common stand and stores a number of drumsticks, mallets, brushes and other accessories in its roomy pouch for ready access when needed.



- Materials** Chrome plated steel
Black textile pouch
- Feature** Strong mounting clamp

CYMBAL STACKERS

The MEINL Cymbal Stackers enable a space saving set up of various cymbals on top of each other.

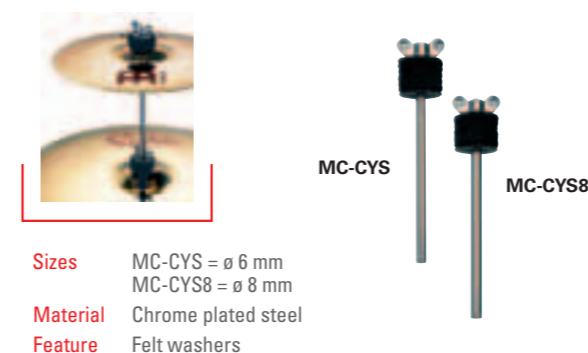

- Sizes** MC-CYS = ø 6 mm
MC-CYS8 = ø 8 mm
- Material** Chrome plated steel
- Feature** Felt washers

CYMBAL HOLDER

This MEINL holder comfortably places any cymbal within a drum or percussion set up.

- Material** Chrome plated steel
- Features** Knurled surface
Felt washers

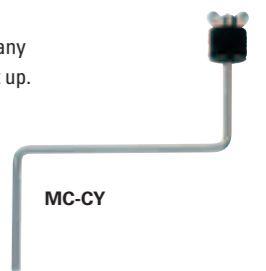



NINO® PERCUSSION

FIRST MOVE

The new generation of musical instruments for early childhood education.

NINO® instruments meet exactly the requirements of early childhood education and are perfectly suitable for the use in kindergartens, schools, music therapy and for musical activities at home.

The easy handling and an appealing design are standard for all NINO® instruments. They are noteworthy due to their professional features, the great sound and their outstanding quality. The strong, childproof workmanship guarantees years of trouble-free use of all NINO® instruments.



CONGA SETS

NINO® Congas are famous for their professional workmanship. Available are fiberglass or wood sets. They all include basket stands and can therefore be played individually or in a set configuration.

NINO910 WOOD CONGA SET

The NINO910 Wood Congas are ideal for first time players or schools. Height adjustable stands included.



- Sizes** 9" & 10" 28" tall
- Material** Rubber Wood (*Hevea brasiliensis* Muell.-Arg.)
- Features** Hand selected buffalo heads
Rounded rims for playing comfort
Black powder coated hardware
- Includes** Height adjustable basket stands with quick set up system
Tuning key
- Colour** NT = Natural

NINO89 WOOD CONGA SET

The NINO89 Wood Congas can be played standing up or sitting down and are therefore the perfect congas for children in kindergartens.



- Sizes** 8" & 9" 22" tall
- Material** Rubber Wood (*Hevea brasiliensis* Muell.-Arg.)
- Features** Hand selected buffalo heads
Rounded rims for playing comfort
Black powder coated hardware
- Includes** Basket stands
Tuning key
- Colour** NT = Natural

FIBERGLASS CONGA SET

Our fiberglass is a high quality material, manufactured by hand, into especially powerful sounding shells. The advantage over wood congas is the lower weight which makes handling much easier. The model with its colourful Harlekin® design will certainly attract attention.



- Sizes** 8" & 9" 22" tall
- Material** Premium fiberglass
- Features** Hand selected buffalo heads
Rounded rims for playing comfort
Black powder coated hardware
- Includes** Basket stands
Tuning key
- Colour** HK = Harlekin®

NINO® CONGA BAG

The NINO® Conga Bag is designed to supply reliable protection while transporting the instrument. It holds congas up to 10" diameter.



- Size** Up to 10"
- Material** Padded nylon
- Features** External pocket
Shoulder strap
Carrying grip

ORIGINAL AFRICAN STYLE ROPE TUNED WOOD DJEMBES

NEW

The NINO® Original African Style Rope Tuned Wood Djembes are carved from one solid piece of plantation grown Mahogany Wood. These high quality instruments are crafted with great attention to detail and provide an outstanding sound. The complex rope tuning system guarantees an ideal and long lasting tuning of the instrument without the use of any metal or sharp edges. Due to the small size and light weight, they are the perfect drums for young children.

Sizes	Diameter	Tall
XS	6 1/4" - 8 1/4"	11 3/4"
S	7" - 8 1/2"	15 3/4"

PP rope	Thickness	Runners
XS	3mm	20
S	4mm	20



- Material** Mahogany Wood
- Features** Carved from one solid piece of plantation grown Mahogany Wood
Hand selected goat heads
4mm strong high quality PP nylon ropes
Hand carved shells

WOOD DJEMBE

The Djembe is the most popular African drum. Even untrained players are quickly able to draw different tones from this great instrument. The NINO® Wood Djembe has a diameter of 10" and a height of 21" and is the perfect drum for children in kindergarten or elementary school.



- Size** 10" 21" tall
- Material** Rubber Wood (*Hevea brasiliensis* Muell.-Arg.)
- Features** Hand selected goat head
Rounded rim for playing comfort
Black powder coated hardware
Patented Floatune Tuning System
- Includes** Tuning key
- Colour** NT = Natural

NINO® DJEMBE BAG

The NINO® Djembe Bag is designed to supply reliable protection while transporting the instrument. It holds djembes up to 10" diameter.



- Size** Up to 10"
- Material** Padded nylon
- Features** External pocket
Shoulder strap
Carrying grip



CONGA SETS, DJEMBES

NINO910 WOOD CONGA SET, NINO89 WOOD CONGA SET, NINO® CONGA BAG, FIBERGLASS CONGA SET, AFRICAN STYLE ROPE TUNED WOOD DJEMBES, WOOD DJEMBE, NINO® DJEMBE BAG

WOOD BONGOS

The NINO® Wood Bongo is an affordable yet high quality instrument with great versatility in sound. Children love the coloured Harlekin® design!



Sizes 6 1/2" & 7 1/2"
Material Rubber Wood
 (Hevea brasiliensis Muell.-Arg.)
Features Hand selected buffalo heads
 Rounded rims for playing comfort

Includes Tuning key
Colours NT-BK = Natural Shell/Black Hardware
 NT-HK = Natural Shell/Harlekin® Hardware



Rounded rim for playing comfort

ABS BONGOS PLUS

A real alternative! The NINO® ABS Bongo Plus is an affordable bongo with a great sound and functional hardware. Shells made of ABS plastic make this bongo lighter than comparable wood models.



Sizes 6 1/2" & 7 1/2"
Material ABS plastic
Features Hand selected buffalo heads
 Rounded rims for playing comfort
 Black powder coated hardware

Includes Tuning key
Colours BK-BK = Black Shell/Black Hardware
 R-BK = Red Shell/Black Hardware

The tuning system is outstanding in this price range



BONGO STAND

The patented NINO® Bongo Stand has been developed especially for kids and their height in order to offer them a safe and comfortable playing position. It can be tilted in a 90° angle and height adjusted from 31" up to 45" so children can play standing up or sitting down. The NINO® Bongo Stand is also suitable for many other common bongo models.

The latch of the patented NINO® Bongo Stand holds the bongo absolutely stable

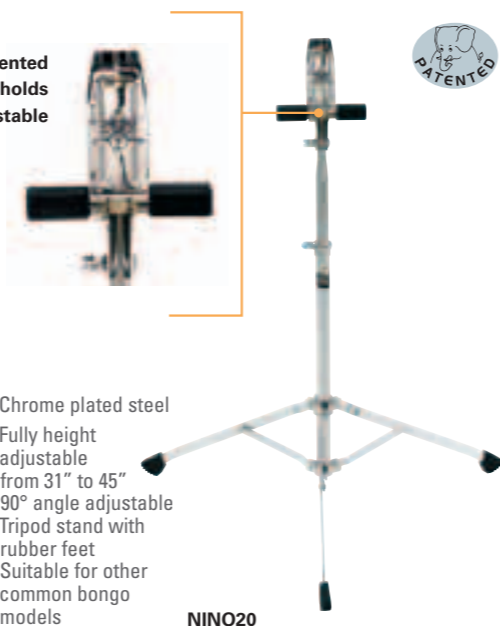

Material Chrome plated steel
Features Fully height adjustable from 31" to 45"
 90° angle adjustable
 Tripod stand with rubber feet
 Suitable for other common bongo models

NINO20

NINO® BONGO BAG

The NINO® Bongo Bag is designed to supply reliable protection while transporting the instrument.



Material Padded nylon
Features Padded shoulder strap
 Carrying grip
 Reinforced bottom

Reinforced bottom

NINO® INSTRUMENTS ARE PERFECT FOR USE IN MUSICAL THERAPY WITH CHILDREN

The direct feedback from the nerves of the skin, muscles, tendons, or sinew, ligaments and joints while hitting a bongo for example, enables reaching a clear proprioception through the direct feedback from the nerves of the skin, the muscles, the tendons and the joints. This is helpful for the development of concentration, attention, and sequencing.

KLAUS HABERECKER

is an accomplished Ergo- and Occupational Therapist. He has also enjoyed an apprenticeship in Sensory Integration Therapy.



Children form their sense of self-perception with music and rhythm in a much more intense manner.

Arithmetic and rhythm are basically very cognate. With many children suffering from dyscalculia, there are many practical exercises with drums and other instruments that are helping them to overcome this problem.



The more I am motivated to reach new goals, the more I am ready to try out new things, for example, changing less useful or antiquated movement patterns



CAJON

The NINO® Cajon delivers the classic sound and due to its smaller dimension, it is especially suitable for a child's size. It is made from high quality materials ensuring long lasting life for this precious instrument.

Not just for children, professional players may find the NINO® Cajon interesting, as they add a different yet authentic Cajon sound to their arsenal of instruments.

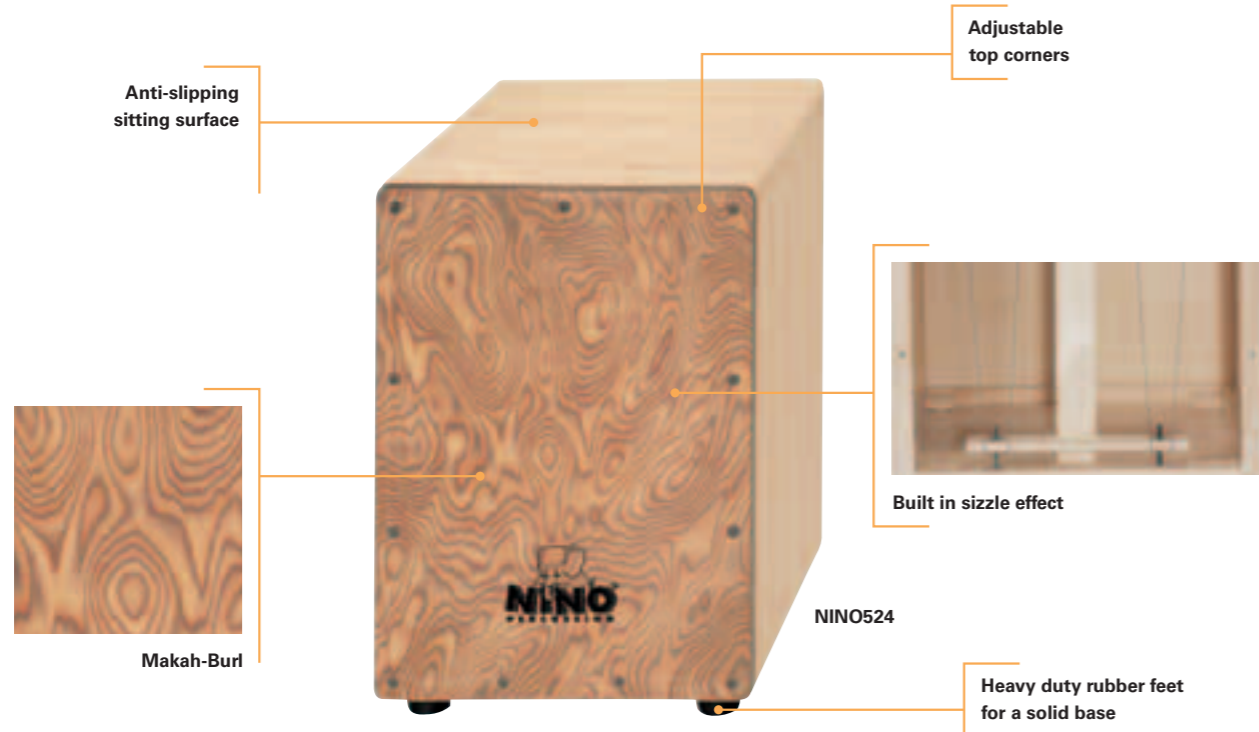

Sizes Length 9.5" (24 cm)
Height 13" (33 cm)
Depth 10" (25.4 cm)
Weight 5.5 pds (2.500 gr)

Materials Frontplate: Makah-Burl
Resonating Body: Rubber Wood
(*Hevea brasiliensis* Muell.-Arg.)

Features Built in sizzle effect
Anti-slipping sitting surface
Adjustable top corners

Includes Allen wrench

NINO® CAJON BAG

The NINO® Cajon Bag is designed to supply reliable protection while transporting the instrument.



Material Padded nylon
Features Padded shoulder strap
Carrying grip

FRAME DRUMS

These NINO® Frame Drums are traditionally equipped with buffalo skin heads and come with a wooden beater. With their warm tone they can be used in various musical occasions.

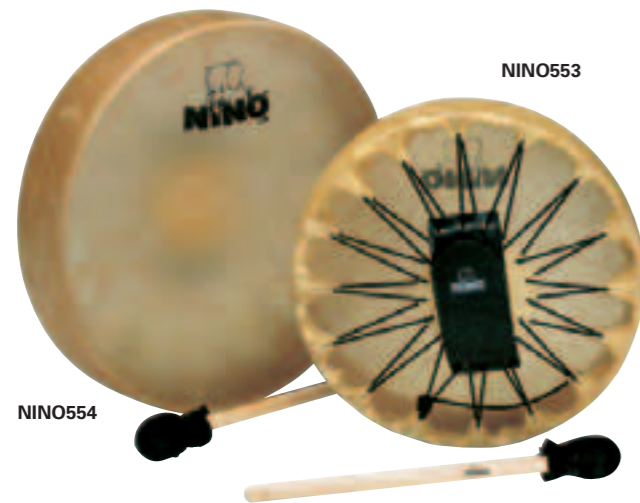

Sizes NINO553 = 12 1/2"
NINO554 = 15"
Material Buffalo skin heads

Feature Velcro strap
Includes Wooden beater

THE DISCOVERY OF A TRADITIONAL INSTRUMENT FOR CHILDREN.



Playing simple rhythms with children helps them to improve their attention span and retentive abilities.



ABS DRUMS

The colourful NINO® ABS Drums are not only durable, they also have a powerful sound. Shells made from ABS plastic and synthetic heads guarantee great stability and a long life. With their low weight of about two pounds and their outstanding workmanship, NINO® ABS Drums are also perfectly suitable for toddlers.

ABS DJEMBES

The drums come pretuned and ready to play right out of the box

- Size 8"
- Material ABS plastic
- Feature Synthetic heads
- Includes Nylon strap
- Colours G/Y = Green/Yellow
R/BK = Red/Black
R = Red



ABS BONGOS

- Sizes 6 1/2" & 7 1/2"
- Material ABS plastic
- Feature Synthetic heads
- Colours G/Y = Green/Yellow
R/BK = Red/Black
R = Red



ABS HAND DRUMS

The multi-coloured NINO® ABS Hand Drums offer more than just tonal variety. The unbreakable shells and durable synthetic heads ensure years of trouble-free use.



- Sizes NINO4 = 6"
NINO45 = 8"
NINO5 = 10"
NINO6 = 12"
- Material ABS plastic
- Feature Synthetic heads
- Includes Wooden beater
- Colours B = Blue
BK = Black
GR = Green
R = Red
Y = Yellow

ABS JINGLE DRUMS

The NINO® Jingle Drums offer enhanced sound options due to attached jingle pairs.

- Size 10"
- Materials ABS plastic with nickelsilver jingles
- Feature Synthetic heads
- Includes Wooden beater
- Colours BK = Black
R = Red



"It's fun! Children love the sound and the colours of these instruments."

The drums come pretuned and ready to play right out of the box



WOOD TAMBOURINES

The NINO® Wood Tambourines feature a sturdy wooden frame along with a nice sparkling sound. They are available in a one row construction with 8 nickelsilver plated steel jingle pairs, or as a two row model with 16 nickelsilver plated steel jingle pairs.



Size 10" diameter
Materials Jingles: Nickelsilver plated steel
 Wooden frame
Feature 1 or 2 row versions available

HEADED WOOD TAMBOURINES

With nickelsilver plated steel jingles and plastic heads firmly attached to the tambourine, this instrument delivers a subtle and gentle tone when played by hand and a voluminous and rich sound that projects well when hit with a stick. Available in a one row construction with 8 jingle pairs, or as a two row model with 16 jingle pairs.

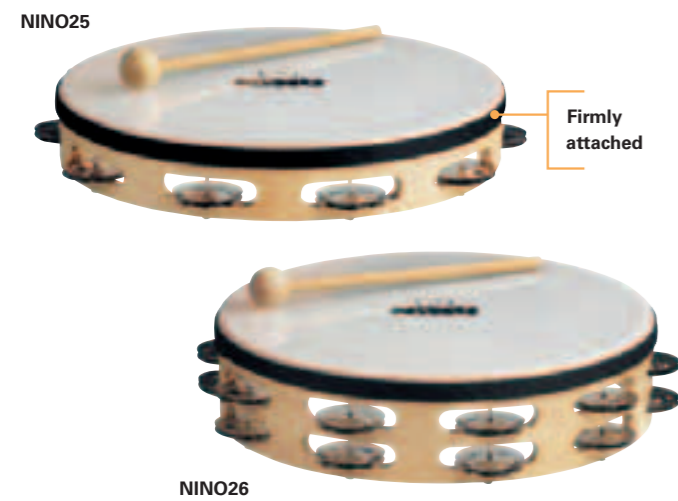

Size 10" diameter
Materials Jingles: Nickelsilver plated steel
 Head: Plastic
 Wooden frame
Feature 1 or 2 row versions available

RACKET TAMBOURINE

The NINO® Racket Tambourine features a sturdy rattan frame along with a nice sparkling sound. It is available as a one row construction with 9 aluminum jingle pairs. An ergonomically shaped handle makes it perfect for children hands.

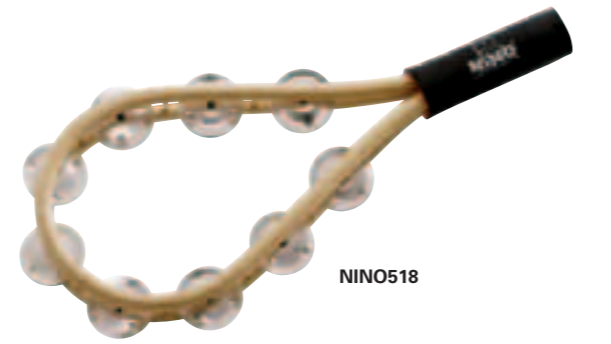

Materials Frame: Rattan
 Jingles: Aluminum
Features Ergonomically shaped and padded handle

A-GO-GO BELL

The NINO® A-Go-Go Bell is perfectly sized for children. It is handmade from high quality steel and produces a loud bell sound.



Material Black powder coated steel



CHIMES

The NINO® Chimes can be mounted on a cymbal stand-, or held by the wooden frame. The 12 bars of the NINO® Chimes are made from a premium aluminum alloy and create a very full and rich sound.

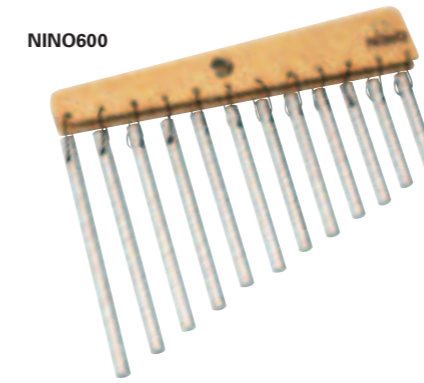

Size 12 bars
Material Silver anodized aluminum alloy

HAND CHIMES

With bars made from a silver anodized aluminum alloy, the NINO® Hand Chimes produce a full and rich sound.



Size 12 bars
Material Silver anodized aluminum alloy

TRIANGLES

NINO® Percussion offers three tonally matched triangles. They have a strong sound with a long sustain.



Sizes 4"
 6"
 8"
Material Steel
Feature Wooden holder with braided nylon strap
Includes Metal beater with rubber padded grip

ENERGY CHIMES

These NINO® instruments have a very cutting "ping" sound. The free floating bars create a very long sustain. NINO® offers three different pitched Energy Chimes, as well as a model with three bars.

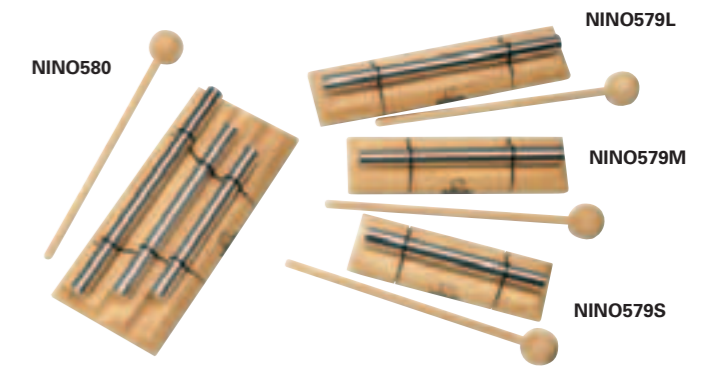

Sizes Small
 Medium
 Large
 3 rows
Material Silver anodized aluminum alloy
Includes Wooden beater

CABASAS

The NINO® Cabasas are made from a wooden cylinder covered with a rippled metal plate, which is surrounded by a net of metal beads. Holding the handle with one hand and scratching the metal beads with the other hand on the metal plate creates the classic cabasa sound. The smaller 2" model was especially designed for a child's hand.

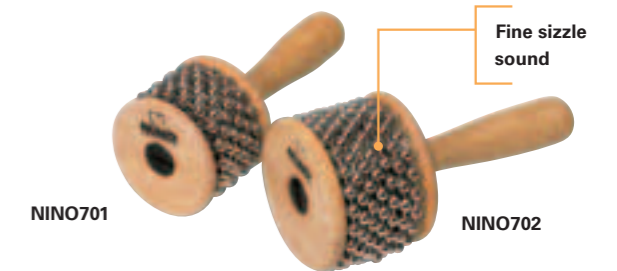

Sizes Small
 Medium
Material Steel chain and cylinder
Feature Ergonomically shaped wooden handle



JINGLE STICKS

The NINO® Jingle Sticks feature six pairs of nickelsilver plated jingles firmly mounted on a plastic frame with a handle. The jingle stick can be played like a tambourine, or like a drumstick on a conga, bongo, or djembe. New and interesting sounds can be achieved with this instrument.



Materials Jingles: Nickelsilver plated steel
Frame: ABS

Features Ergonomically shaped handle
New sound ideas

Colours BK = Black
R = Red
Y = Yellow

MINI GUIROS

The NINO® Mini Guiros are made from high quality material. The sound is achieved by scratching the different surfaces of the guiro.



Size Mini

Includes Wooden scraper

Colours BK = Black
R = Red

PLASTIC MARACAS

The NINO® Plastic Maracas are known for their stability, versatility, and strong, projecting sound.



Material Plastic

Features Ergonomically shaped handle
Sold as pairs

Colours GR = Green
R = Red
Y = Yellow



WOOD EGG MARACAS

Maracas are used for any style of music and are one of the most popular rhythm instruments worldwide. The NINO® Wood Egg Maracas have a nice warm sound and come with an ergonomically shaped handle.



Sizes Small
Medium

Material Rubber Wood
(*Hevea brasiliensis* Muell.-Arg.)

Features Ergonomically shaped handle
Sold as pairs

WOOD MARACAS

The NINO® Wood Maracas sound very focused and have more attack.

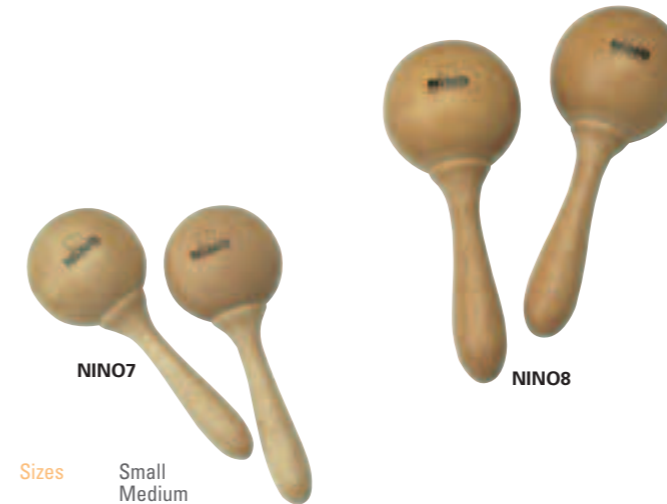

Sizes Small
Medium

Material Rubber Wood
(*Hevea brasiliensis* Muell.-Arg.)

Features Ergonomically shaped handle
Sold as pairs

PLASTIC EGG MARACAS

The NINO® Egg Maracas are made from a special plastic material. They have a very clear and pronounced sound and are perfect maracas for children.



Size 6"

Material Plastic

Features Ergonomically shaped handle
Sold as pairs

Colour R = Red

SKIN MARACAS

NINO® Skin Maracas are entirely hand made and have a warm and mellow sound.



Size Small

Material Natural skin

Features Mellow sound
Ergonomically shaped wood handle
Sold as pairs

SKIN EGG SHAKER

The NINO® Skin Egg Shaker is entirely hand made and has a warm and mellow sound.



Material Natural skin



WOOD FROGS

The NINO® Wood Frogs have gained an enormous popularity over the last few years. Children especially love the authentic "ribbit" sound which is created by scratching the wooden beater on the frog's back. Great fun for kids and adults.

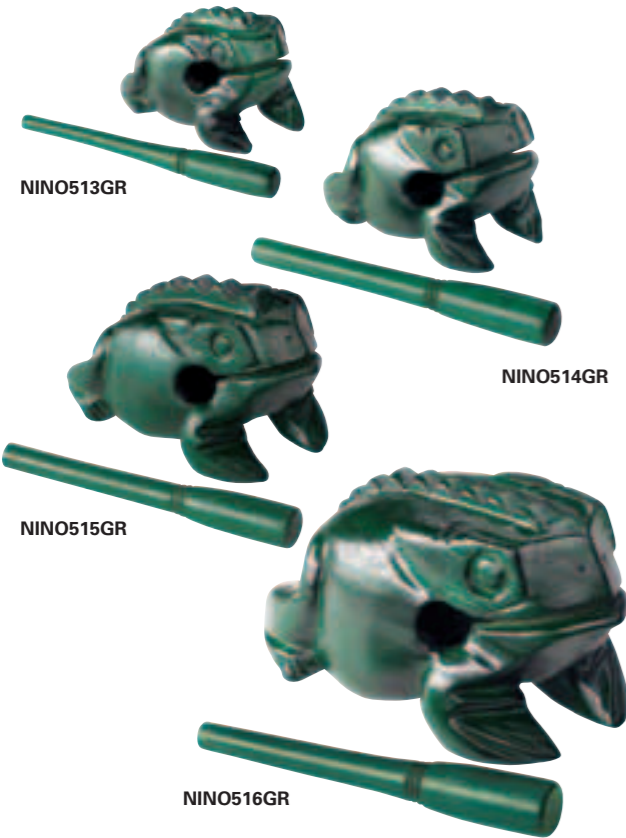

Sizes Small
Medium
Large
X-large

Material Wood

Feature Creates original "ribbit" sound

Includes Wooden scratcher

Colour GR = Green

WOOD ANIMALS

The NINO® Wood Animals are great sounding miniature imitations of a grasshopper, snail, turtle and pig. Scratching the wooden beater on the surface of the instruments creates a nice guiro-like sound. Great fun for kids and adults.



Material Wood

Feature Creates guiro-like sounds

WOOD SHAKERS

Toddlers especially love these little rhythm instruments. NINO® Natural Wood Shakers have different fillings. A cylindrical shaped shaker is available in two different sizes, as well as a square, and a triangular shaped shaker assortment.

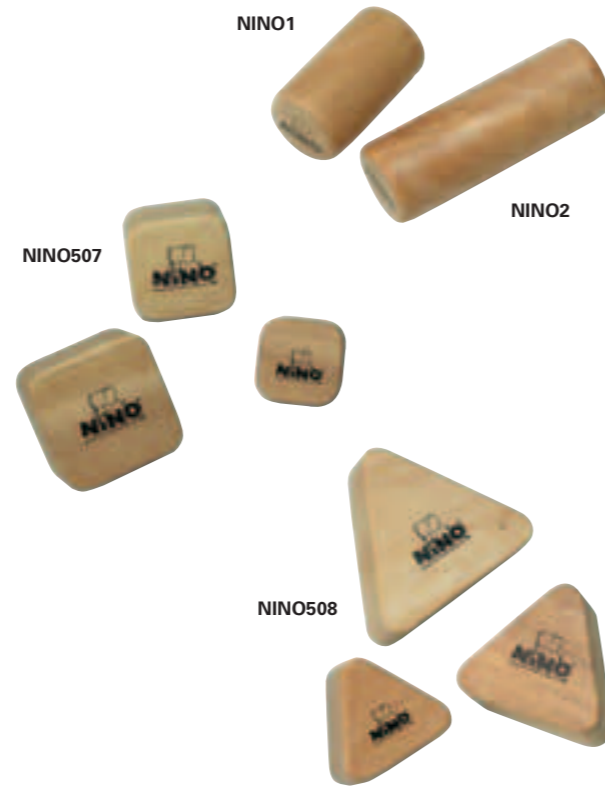

Shapes NINO1 = Cylindrical, small
NINO2 = Cylindrical, large
NINO507 = Square, 3 pcs. set
NINO508 = Triangular, 3 pcs. set

Material Rubber Wood
(*Hevea brasiliensis* Muell.-Arg.)

Feature Different sounding fillings

WOOD EGG SHAKERS

NINO® Wood Egg Shakers are very handy because of their shape. They also have a great sound with various pitches depending on their size.

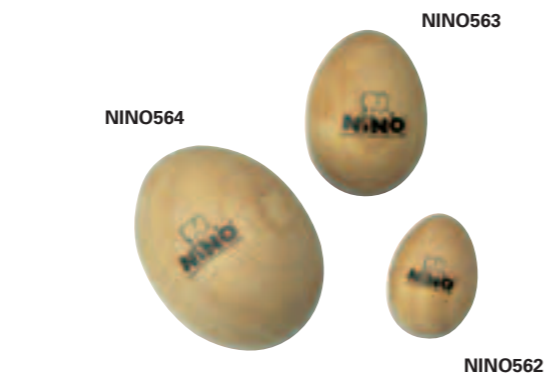

Sizes Small
Medium
Large

Material Rubber Wood
(*Hevea brasiliensis* Muell.-Arg.)

ORIENTAL WOOD TONE BLOCK

The NINO® Oriental Wood Tone Block produces a high pitched and open sound.



NINO572

Material Rubber Wood
(*Hevea brasiliensis* Muell.-Arg.)

Feature Ergonomically shaped handle

Includes Wooden beater

WOOD STIRRING DRUM

The eight wooden tongues produce different pitches when they are struck separately, like playing a xylophone. By stirring in the drum with the included beater a scale can be played. The combination of a stirring drum with a handle is an original MEINL innovation.



NINO556

Material Rubber Wood
(*Hevea brasiliensis* Muell.-Arg.)

Feature Ergonomically shaped handle

Includes Wooden beater

WOOD BALL STIRRING DRUM

The NINO® Wood Ball Stirring Drum is a further development of the familiar stirring drum. The instrument is based on a clever design. When playing the drum, a wooden ball fastened to a nylon string strikes the tonally matched wooden tongues and produces a harmonic sound.

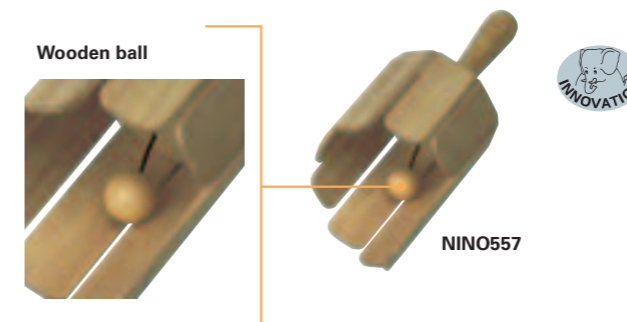

Material Rubber Wood
(*Hevea brasiliensis* Muell.-Arg.)

Feature Ergonomically shaped handle

SOUVENIR INSTRUMENTS

The NINO® Souvenir Instruments are very popular as small gifts or ornaments. They are available as a conga, djembe, or bongo. Great fun for everybody.



Size 3" tall

Material Rubber Wood
(*Hevea brasiliensis* Muell.-Arg.)

Feature Natural hide skins



WOOD CLAVES

Claves are an essential instrument in Latin music and shouldn't be missing from any percussion set up. The NINO® Wood Claves are available as regular sized models. A second pair was especially designed to fit a child's hand size.

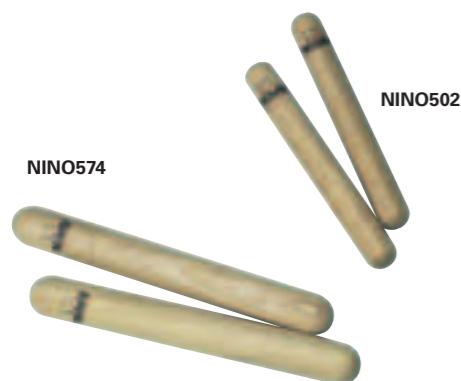

Sizes Small
Regular
Material Rubber Wood
(*Hevea brasiliensis* Muell.-Arg.)
Feature Sold as pairs

WOOD BLOCKS

The Wood Block is probably one of the oldest rhythm instruments and should be part of any percussion group. The NINO® Wood Blocks have an impressive sound and are available in two sizes.

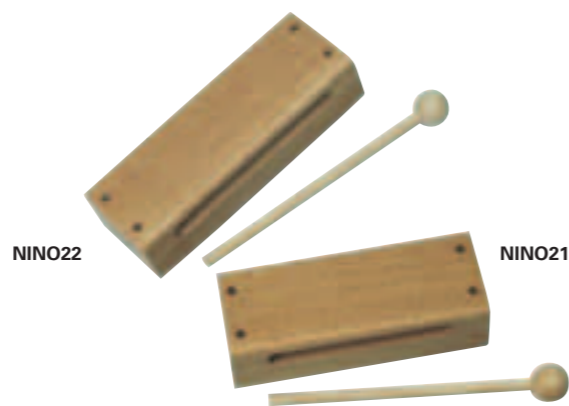

Sizes Medium
Large
Material Rubber Wood
(*Hevea brasiliensis* Muell.-Arg.)
Includes Wooden beater

WOOD GUIRO

The guiro is an important instrument which plays a very important part in any percussion set up. Striking the tonal grooves of the NINO® Wood Guiro creates many different sounds.



Material Rubber Wood
(*Hevea brasiliensis* Muell.-Arg.)
Includes Wooden striker

WOODPECKER

The NINO® Woodpecker creates an amazingly realistic "woodpecker" sound. It's a great effect instrument which is also interesting for professional players who look to increase their sound arsenal.



Material Rubber Wood
(*Hevea brasiliensis* Muell.-Arg.)

WOOD TONE BLOCK

The NINO® Wood Tone Block comes with two tonally matched resonating bodies.

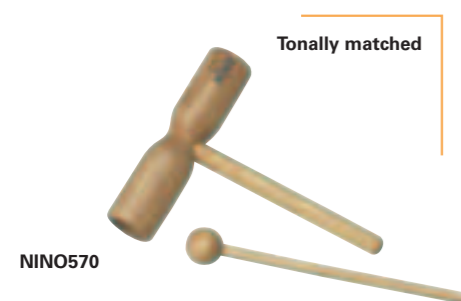

Material Rubber Wood
(*Hevea brasiliensis* Muell.-Arg.)
Feature Tonally matched resonating bodies
Includes Wooden beater

WOOD A-GO-GO'S

The NINO® Wood A-go-go's are played with a wooden beater and produce a powerful sound. They can also be scratched like a guiro. These two playing styles leave room for creativity.

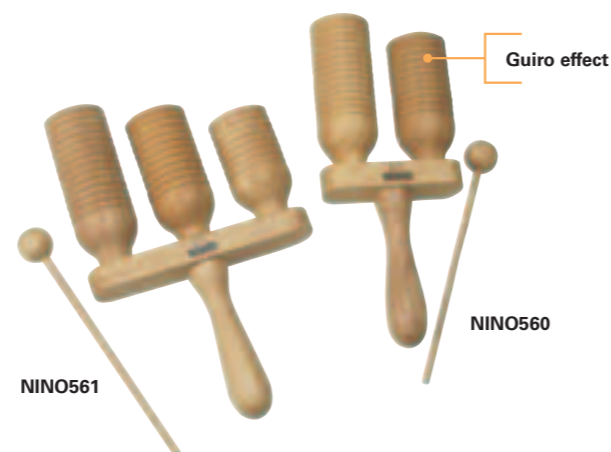

Sizes 2 rows
3 rows
Material Rubber Wood
(*Hevea brasiliensis* Muell.-Arg.)
Features Different playing options
Ergonomically shaped handle
Includes Wooden beater

WOOD GUIRO SHAKER

The NINO® Wood Guiro Shaker is equipped with a filling and combines a shaker as well as a guiro sound in one instrument.

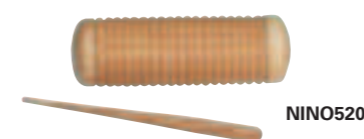

Material Rubber Wood
(*Hevea brasiliensis* Muell.-Arg.)
Feature Additional shaker sound
Includes Wooden striker

GANZA SHAKERS

The NINO® Ganza Shakers produce a voluminous sound due to their size.



Sizes Small
Medium
Materials Rattan with coconut bottom

CAXIXI

The NINO® Caxixi produces a clear and cutting sound.



Materials Rattan with natural skin hide bottom

DOUBLE SHAKER

The NINO® Double Shaker produces a clear and cutting sound with enhanced volume.



Materials Rattan with natural skin hide bottom

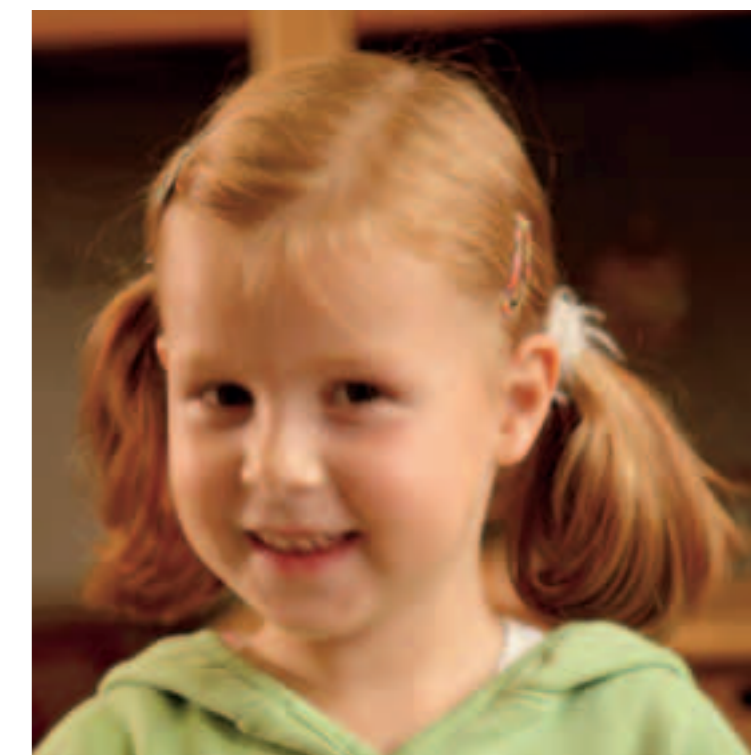

BOTANY SHAKERS

The NINO® Botany Shakers are made from a high quality plastic material filled with a specially nice sounding substance. These fruit and vegetable imitations look amazingly real and create a great variety of sounds.

NINO® Botany Shakers have been tested for saliva resistance and can therefore be given to toddlers without any worries.

“FRUIT” ASSORTMENT, 4 pcs.



Material Plastic
Feature Botany Shaker Assortment, 4 pcs. “fruit”

NINOSSET100



“VEGETABLE” ASSORTMENT, 4 pcs.



Material Plastic
Feature Botany Shaker Assortment, 4 pcs. “vegetable”

NINOSSET101

BOTANY SHAKER ASSORTMENT, 36 pcs.



Material Plastic
Feature Botany Shaker Assortment, 36 pcs. incl. 2 baskets of each 18 pcs.

VE36-NINO536

EGG SHAKERS

NINO® Egg Shakers are vital to every percussion collection. They have an extremely pronounced and crystal clear sound.



Material Plastic
Colours B = Blue
BK = Black
GR = Green
R = Red
Y = Yellow

EGG SHAKER, SMALL



NINO540MBR

Size Small
Material Plastic
Colour BR = Brown

ASSORTMENT, 4 pcs.



NINOSSET540

Material Plastic
Sets Egg Shaker Set 4 pcs.
Egg Shaker Set 80 pcs. including elephant shaped basket

ASSORTMENT, 80 pcs.



VE80-NINO540

BALL SHAKER

The two shakers are firmly attached to each other with a strong cord. By tightly holding one ball and rhythmically swinging the other one, many sounds can be achieved.

Material Plastic
Feature Attractive Harlekin® design



NINO509

NINO® SETS

NINO® instruments have been designed to meet the demands of early childhood education and are perfectly suitable for the use in kindergartens, schools, music therapy and musical activities in the family. Available are two different NINO® Percussion collections which come in a durable nylon Harlekin® design bag. It's the perfect activity for small groups of up to 8 children.

NINOSET1



NINOSET1

- Contents**
- 1 x ABS Hand Drum 6"
 - 1 x Wooden Beater
 - 1 x Wood Shaker, large
 - 1 x Skin Maracas pair, small
 - 1 x Jingle Stick
 - 1 x Harlekin® bag

NINOSET4



NINOSET4

- Contents**
- 1 x Wood Guiro
 - 1 x Caxixi
 - 1 x Wood Claves pair, small
 - 1 x Triangle, 4"
 - 1 x Egg Shaker
 - 1 x Egg Shaker, small
 - 1 x Botany Shaker, Banana
 - 1 x Botany Shaker, Apple
 - 1 x Harlekin® bag

Contents of NINOSET4



CYMBALS

These excellent sounding NINO® Cymbals are made in Germany. They are a high quality product and perfect for music education.



NINO-NS355

NINO-NS305

- Sizes** 12"/30.5 cm
14"/35.5 cm
- Material** Nickel silver
- Includes** Leather strap

CYMBAL PAIRS

NINO® Cymbal Pairs are made in Germany from premium alloys. Different sizes are available in bronze, brass, or nickel silver. All cymbal pairs are tonally matched and are equipped with a leather strap.



- Sizes** 7"/17.5 cm
8"/20.0 cm
- Materials** Bronze, brass, or nickel silver
- Includes** Leather straps

TENOR GONG

Children love the NINO® Tenor Gong which is hand made from a special alloy. Its smooth and relaxing tone reveals magic.



NINO900

- Size** 12"
- Material** Special alloy
- Feature** Smooth and relaxing tone
- Includes** Holder
Beater

MUSIC BAGS

Handy bags made from durable nylon are always useful. These NINO® Music Bags are available in red and the Harlekin® design. Many separate compartments make them ideal for all kind of activities.



- Material** Nylon
- Feature** Many compartments
- Colours** HK = Harlekin®
R = Red

NINO® RHYTHM SETS

These two NINO® Rhythm Sets include 12 or 15 individual instruments. They are perfect for use in kindergarten, schools, or percussion groups. These collections of different instruments are the ideal way to explore the complete NINO® world of percussion and rhythm.

NINOSET12



NINOSET12

Contents 1 x Wood Claves pair, large
1 x Triangle, 6"
1 x ABS Hand Drum 10"
1 x Tambourine, one row
1 x Energy Chime, medium

1 x Wood Guiro
1 x Skin Maracas pair, medium
1 x Double Shaker
2 x Egg Shaker
1 x Wood A-Go, two rows

NINOSET15



NINOSET15

Contents 1 x Wood Claves pair, small
1 x Triangle, 4"
1 x ABS Hand Drum 6"
1 x Mini Guiro
1 x Skin Egg Shaker
1 x Egg Maracas pair, small
1 x Double Shaker

1 x Wood Shaker Assortment 3 pcs., square
1 x Wood-Block, medium
1 x Botany Shaker, Banana
1 x Egg Shaker
1 x Jingle Stick
1 x Basket



NINO® PERCUSSION

Model No.	Size	Height	Material	Features	SPARE PARTS					
					Head	Rim	Lug	Bracket	Page	
			Rubber Wood Premium Fiberglass ABS Plastic Mahogany Wood	Hand selected buffalo heads Hand selected goat heads Rounded rims Floater Tuning System Rope Tuning System						
CONGA SETS										
NINO910	9"	28"			HEAD-NI910-9	RIM-NI910-9	LUG-NINO910	BRACKET-NI89	136	
NINO910	10"	28"			HEAD-NI910-10	RIM-NI910-10	LUG-NINO910	BRACKET-NI89	136	
NINO89	8"	22"			HEAD-NINO89-8	RIM-NINO89-8	LUG-NINO89	BRACKET-NI89	136	
NINO89	9"	22"			HEAD-NINO89-9	RIM-NINO89-9	LUG-NINO89	BRACKET-NI89	136	
AFRICAN STYLE ROPE TUNED WOOD DJEMBES										
NINO-ADJ2-XS	6 1/4"–8 1/4"	11 3/4"			HEAD-60				137	
NINO-ADJ2-S	7"–8 1/2"	15 3/4"			HEAD-61				137	
WOOD DJEMBE										
NINO23	10"	21"			HEAD-NINO23	RIM-NINO23	LUG-NINO23		137	
BONGOS										
NINO3	6 1/2"				HEAD-NINO3-65	RIM-NI3-65-BK	LUG-NINO3		138	
NINO3	7 1/2"				HEAD-NINO3-75	RIM-NI3-75-BK	LUG-NINO3		138	
NINO3	6 1/2"				HEAD-NINO3-65	RIM-NI3-65-BL	LUG-NINO3		138	
NINO3	7 1/2"				HEAD-NINO3-75	RIM-NI3-75-G	LUG-NINO3		138	
NINO17	6 1/2"				HEAD-NINO3-65	RIM-NI3-65-BK	LUG-NINO3		138	
NINO17	7 1/2"				HEAD-NINO3-75	RIM-NI3-75-BK	LUG-NINO3		138	
SPARE PARTS FOR STANDS										
8" Basket Stand for NINO89					NISTAND-08				136	
9" Basket Stand for NINO89					NISTAND-09				136	
9" Basket Stand for NINO910					NISTAND09				136	
10" Basket Stand for NINO910					NISTAND10				136	
OTHER PARTS										
Lug Oil					SPARE-09					
Wood Beater					NINO9					
Triangle Beater					NINO567					
Tuning Key, 13mm, chrome					KEY-04					



THE SAFETY

NINO® instruments have been tested by the Landesgewerbeanstalt Bayern, Germany (LGA), Institute for the Testing of Goods and Quality Monitoring and have been awarded with the LGA Test Certificate.

This means that NINO® instruments comply with the strict requirements of the European Community Directives 88/378EC and 87/357/EC.

PRODUCT TESTING

All NINO® instruments are regularly tested for safety and sanitary harmlessness according to the EC Directives 88/378/EC (Toy Safety Directive) and 87/357/EC (Limitation of Food).

The tests are carried out by the Landesgewerbeanstalt Bayern, Germany (LGA), a modern testing and consulting services organization with over 30 branches worldwide.

As a recognized institute for the testing of goods and quality monitoring, the LGA is entitled to award the GS and LGA test marks which are accepted throughout Europe and internationally as a guarantee of safety.



NINO® INSTRUMENTS PASS THE FOLLOWING TESTS

Testing in dependence on the Toy Safety Directive (88/378/EC)
Mechanical and physical characteristics
Inflammability
Migration of certain parts
Saliva and perspiration resistance
Colorfastness
Determination of the content of Pentachlorophenol (PCP)
Testing with regard to pesticides
Valuation in accordance with EC Directive 87/357/EC



CERTIFICATION

After passing all tests, the internationally accepted LGA Test Certificate was awarded for all NINO® percussion instruments. This certificate vouches for quality and safety.

MATERIAL & ECOLOGY

Wood is a raw material which is present in almost every part of our daily life. Trees are an important part of the complex eco-system while healthy forests are imperative for the Earth's atmosphere.

Only Rubber Wood (*Hevea brasiliensis* Muell.-Arg.) is used for the making of NINO® percussion instruments. This wood fulfils the CITES regulations ("Convention on International Trade in Endangered Species of Wild Fauna and Flora") and originates from environmentally controlled forests from industrial wood plantations.

WOOD FROM ENVIRONMENTALLY CONTROLLED WOOD PLANTATION

Thailand is a logical manufacturing base for percussion instruments due to the fact that the *Hevea Brasiliensis*, which was indigenous to Brazil and later transported by way England to Asia, has been commercially grown in Southeast Asia during the last century on plantation farms for the production of Latex.

The traditional plantation of Rubber Wood (*Hevea brasiliensis* Muell.-Arg.) meets all ecological requirements. In a natural evolution, new trees are planted and the older ones, which have ceased to provide latex, are harvested. In this way, plenty of raw material is available and the valuable rain forest eco-system is preserved.

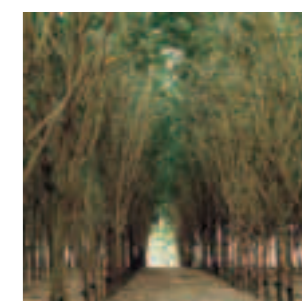

Rubber Wood plantation farm in Thailand