

**2008**

**THE MEINL BOOK OF PERCUSSION**

**PASSION FOR DETAILS**





## DIRECTORY

| PRODUCT GROUP   | PAGE |
|-----------------|------|
| CAJONS          | 2    |
| DJEMBES         | 18   |
| CONGAS          | 36   |
| BONGOS          | 60   |
| TIMBALES        | 74   |
| SAMBA           | 84   |
| STEELBELLS      | 96   |
| FRAME DRUMS     | 100  |
| TAMBOURINES     | 102  |
| CLAVES          | 105  |
| CHIMES          | 106  |
| CABASAS         | 109  |
| SHAKERS         | 110  |
| GUIROS          | 114  |
| MARACAS         | 115  |
| RITUAL DRUMS    | 116  |
| SHEKERES        | 117  |
| IBO DRUMS       | 120  |
| DOUMBEKS        | 122  |
| DARBUKAS        | 124  |
| DANCING DRUMS   | 126  |
| HARDWARE        | 127  |
| CANDELA CYMBALS | 130  |
| NINO®           | 133  |
| MERCHANDISE     | 160  |



**“ For 30 years ...**

we've crafted the finest percussion instruments ...  
instruments on which I am proud to put our family name.”

Reinhold Meinl, Owner





Christian Franz, Germany  
Hobby musician at a home recording session



## CAJONS

### MIPA AWARD FOR MEINL CONGA CAJON

The "Musikmesse International Press Award" is annually presented by 55 music magazines from all over the world that get together and vote for the best products in certain categories.

The MEINL Conga Cajon won the MIPA Award in the "Best Percussion Product" category.





## PICKUP CAJONS

The MEINL Pickup Cajons are equipped with the DST pickup microphone and the A1.2 pre-amp system with volume control from B-Band®. This active system includes a specially designed pre-amp, high quality endpin output jack and a durable battery. The structure is light in mass adding very little weight to the instrument. The sound reproduction is amazingly pure and clear. This installed microphone system provides comfortable and easy handling in live situations. Plug in and play!

DST pickup microphone from

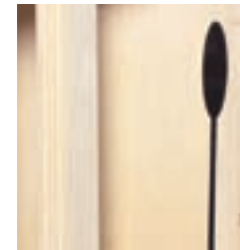

Inside

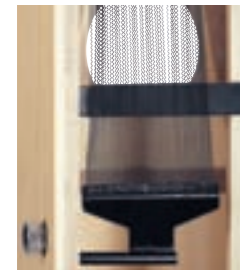

Fully adjustable snare wires

CAJ9SNT-M



Heavy duty rubber feet for a solid base

CAJ8MB-M



Adjustable sizzle effect with integrated string mute system (patent pending)



**Materials** CAJ9SNT-M  
Frontplate: American White Ash (*Fraxinus americana* L.)  
Resonating body: Rubber Wood (*Hevea brasiliensis* Muell.-Arg.)  
CAJ8MB-M  
Frontplate: Makah-Burl  
Resonating body: Rubber Wood (*Hevea brasiliensis* Muell.-Arg.)

**Features** CAJ9SNT-M  
DST pickup microphone  
Active A1.2 pre-amp system with volume control from B-Band®  
Adjustable top corners  
Internal, adjustable snare wires  
Padded sitting surface  
Wide sound options  
CAJ8MB-M  
DST pickup microphone  
Active A1.2 pre-amp system with volume control from B-Band®  
Adjustable top corners  
Adjustable sizzle effect with integrated string mute system  
Padded sitting surface  
Wide sound options

**Includes** CAJ9SNT-M  
9-volt battery  
CAJ8MB-M  
9-volt battery  
Allen wrench

**Finish** Matte



Rear view

Active A1.2 pre-amp system with volume control from



## BASS PEDAL CAJON (patent pending)

The MEINL Bass Pedal Cajon features another unique innovation, which proves once again MEINL's leading R/D status in the worldwide percussion scene. A pedal attached to the cajon adjusts the amount of pressure used to press the snare wires against the front plate, and can even be turned off completely. This system allows the player to change the settings of the snare wires while playing a rhythm with both hands without interruption. Due to its size being bigger than the standard MEINL Cajons, the instrument has more projection and bass frequencies.

**Materials** Frontplate: Ebony  
Resonating body: Rubber Wood (*Hevea brasiliensis* Muell.-Arg.)  
**Features** Foot pedal  
Internal, adjustable snare wires  
Great bass tones  
Adjustable top corners  
Padded sitting surface  
Wide sound options  
**Finish** Matte

More volume  
more bass

CAJ5EB-M

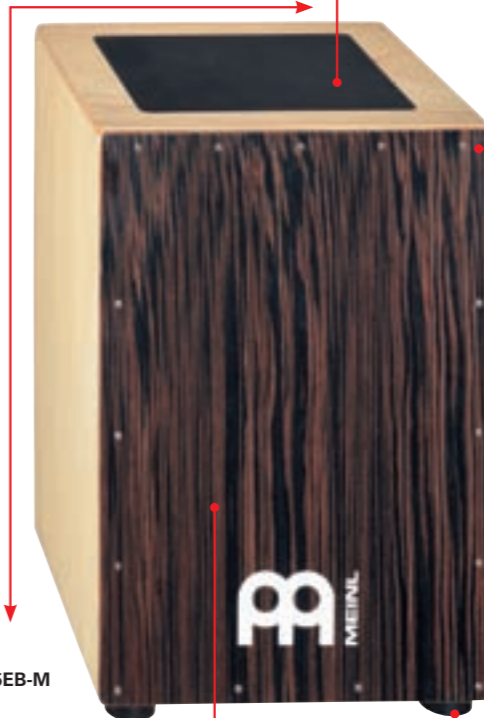

Padded sitting surface



Adjustable top corners

Foot pedal for a quick on/off switch of the snare wires (patent pending)



Heavy duty rubber feet for a solid base

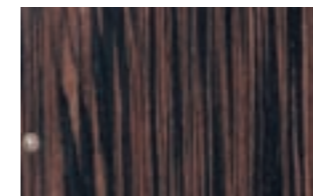

Ebony





## SNARE CAJONS

To equip a Cajon with fully adjustable snare wires is an original MEINL innovation and proves yet again MEINL's leading R/D status in the worldwide percussion scene. The snares touch the frontplate from the inside and deliver the classical cajon sound, which is requisite in Flamenco music. A knurled knob adjusts the amount of pressure used to press the snare wires against the frontplate. Rattling ranging between light and sensitive to very loud can be achieved through adjustment. The entire snare unit can even be turned off completely.



**Materials** CAJ2BB-M  
Frontplate: OceanBlu Burl  
Resonating body: Burl  
CAJ2ELM-M  
Frontplate: Elm  
Resonating body: Rubber Wood  
(*Hevea brasiliensis* Muell.-Arg.)  
CAJ2RO-M  
Frontplate: Cherry  
Resonating body: Red Oak

**Features** Adjustable top corners  
Internal, adjustable snare wires  
Padded sitting surface  
Wide sound options  
**Finish** Matte

**Materials** CAJ1BKSP-M  
Frontplate: Premium fiberglass  
Resonating body: Rubber Wood  
(*Hevea brasiliensis* Muell.-Arg.)  
CAJ1EB-M  
Frontplate: Ebony  
Resonating body: Rubber Wood  
(*Hevea brasiliensis* Muell.-Arg.)  
CAJ1SNT-M  
Frontplate: American White Ash  
(*Fraxinus americana* L.)  
Resonating body: Rubber Wood  
(*Hevea brasiliensis* Muell.-Arg.)

**Features** Adjustable top corners  
Internal, adjustable snare wires  
Padded sitting surface  
Wide sound options  
**Finish** Matte

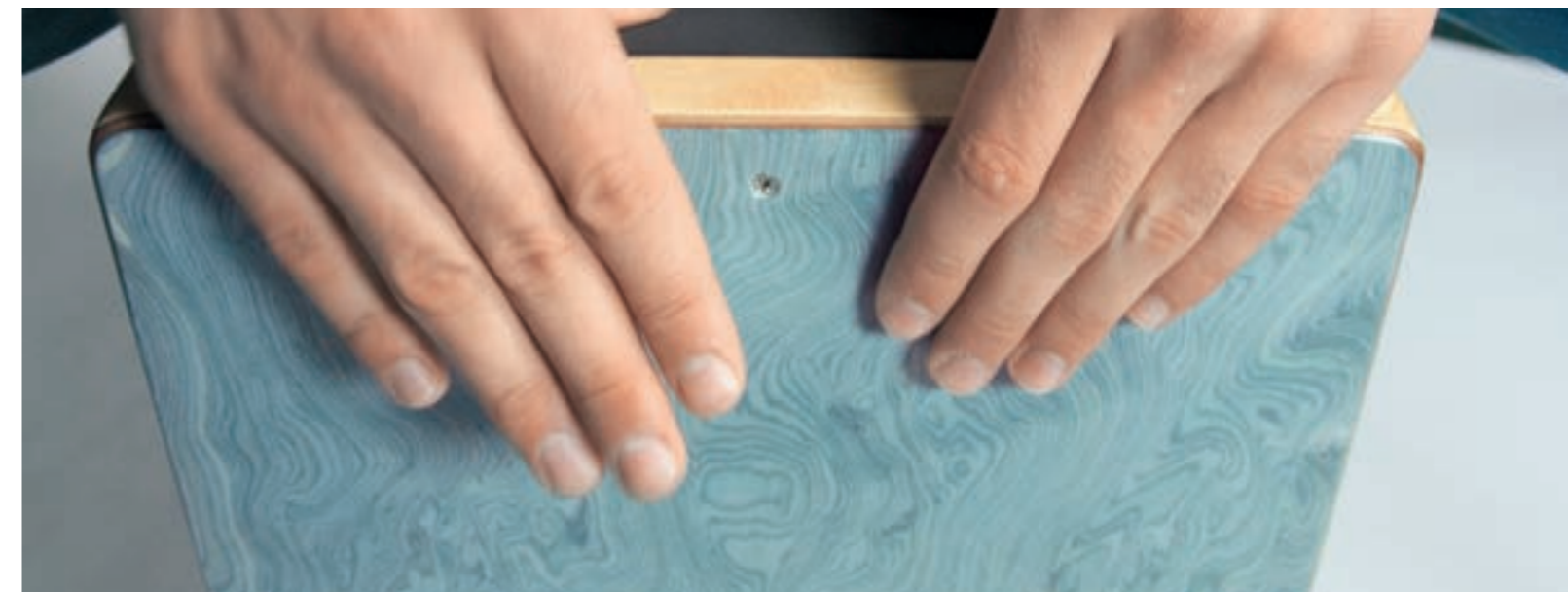



## 30<sup>TH</sup> ANNIVERSARY EDITION PEDAL CAJON (patent pending)

**NEW**

The MEINL 30<sup>TH</sup> Anniversary Pedal Cajon features our new patent pending ergonomic curved frontplate, made from exotic African Bubinga Wood. The new ergonomically shaped frontplate has a slight curve (Ergo-Shape) that follows the natural contour of your hands for extreme comfort when playing – you will feel the difference! This cajon also features our patent pending foot pedal.



## 30<sup>TH</sup> ANNIVERSARY EDITION STRING CAJON (patent pending)

**NEW**

The MEINL 30<sup>TH</sup> Anniversary String Cajon features an exotic Bubinga frontplate and two new innovations: The frontplate is ergonomically curved for maximum comfort and sound development, and the string mute system gives your sound extra precision and control. The Bubinga frontplate is a rich and beautiful reddish coloured African wood. Altogether this 30th Anniversary edition is a proud addition to the MEINL line of cajons.



## MEINL'S NEW ERGO-SHAPE

Ergonomic curved frontplate



## STRING CAJONS (patent pending)

**NEW**

MEINL Cajons feature a built-in adjustable sizzle effect. Strings, which touch the frontplate on the inside and span from top to bottom, deliver a sensitive rattle that can be adjusted to fit various musical applications. The patented integrated string mute system controls the tension of the strings and ensures a dry and crisp sizzle effect. The MEINL String Cajons come bundled with the Professional Cajon Bag.



- Materials** CAJ3MB-M  
Frontplate: Makah-Burl  
Resonating body: Rubber Wood (*Hevea brasiliensis* Muell.-Arg.)  
CAJ3VSB-M  
Frontplate: Birch  
VSB = Vintage Sunburst  
Resonating body: Rubber Wood (*Hevea brasiliensis* Muell.-Arg.)
- Features** Adjustable top corners  
Adjustable sizzle effect  
Integrated string mute system  
Wide sound options  
Birch for new sound colour  
Padded sitting surface
- Includes** Professional Cajon Bag made out of heavy duty padded nylon  
Allen wrench
- Finish** Matte

## STRING FIBERGLASS CAJON (patent pending)

**NEW**

This MEINL Cajon features a frontplate made from premium fiberglass and resonating body made from Rubber Wood, resulting in a modern look and additional sound options.



- Materials** Frontplate: Premium fiberglass  
Resonating body: Rubber Wood (*Hevea brasiliensis* Muell.-Arg.)
- Features** Adjustable top corners  
Adjustable sizzle effect  
Integrated string mute system  
Wide sound options  
Padded sitting surface
- Includes** Professional Cajon Bag made out of heavy duty padded nylon  
Allen wrench



Sabine Vieten, Germany (Die Happy)





## HEADLINER® SERIES CAJONS

The MEINL Headliner® Series Cajon delivers the classic cajon sound at an affordable price and can be used in Flamenco or world music. It is also very useful during unplugged gigs for delivering the rhythmic foundation for a whole band when a full drum set can't be used. For more sound options, the top corners of the cajon can be adjusted, allowing the player to customize the amount of snap desired.



**Materials**  
**HCAJ1NT**  
 Frontplate: Rubber Wood (*Hevea brasiliensis* Muell.-Arg.)  
 Resonating body: Rubber Wood (*Hevea brasiliensis* Muell.-Arg.)  
**HCAJ1MH-M**  
 Frontplate: Mahogany  
 Resonating body: Rubber Wood (*Hevea brasiliensis* Muell.-Arg.)

**Features** Adjustable top corners  
 Adjustable sizzle effect  
 Anti-slip sitting surface  
**Includes** Allen wrench  
**Finish** Matte

## HEADLINER® DESIGNER SERIES CAJONS

The MEINL Headliner® Designer Series Cajons are available in four different motifs: Original Camo, Flower Power, Cork, and Cow Skin. The cloth-covered body produces a drier and crisper sound compared to conventional bare wood construction. These cajons also feature a built-in sizzle effect and guarantee great attention due to their eye-catching finish.



**Materials** Cloth-covered Rubber Wood (*Hevea brasiliensis* Muell.-Arg.)  
**Features** Adjustable sizzle effect  
 Adjustable top corners

**Includes** Allen wrench  
**Finish** CF = Cork  
 COW = Cow Skin (synthetic hair)  
 FP = Flower Power  
 OC = Original Camo





## PALITO

The MEINL Palito is another addition to the comprehensive variety of our cajon instruments. Strings which touch the playing surface on the inside deliver a sensitive sizzle effect that fits to various musical applications. Its compact size and light weight makes it the perfect companion on the road.



Adjustable sizzle effect

PLCA1MB-M

Makah-Burl



- Materials** Playing surface: Makah-Burl  
Resonating body: Rubber Wood (*Hevea brasiliensis* Muell.-Arg.)
- Features** Adjustable sizzle effect  
Compact size
- Includes** Allen wrench
- Finish** Matte

## CONGA CAJON

The MEINL Conga Cajon is another milestone in the development of unique and innovative percussion instruments. It can be played traditionally in a trio configuration or individually as a normal cajon or as a hand-drum incorporated in a percussion set up. Integrated in a drum set configuration, it makes a great sonic addition for the drummer's means of expression. The MEINL Conga Cajon features MEINL's innovative internal and adjustable snare wire system for enhanced sound possibilities.

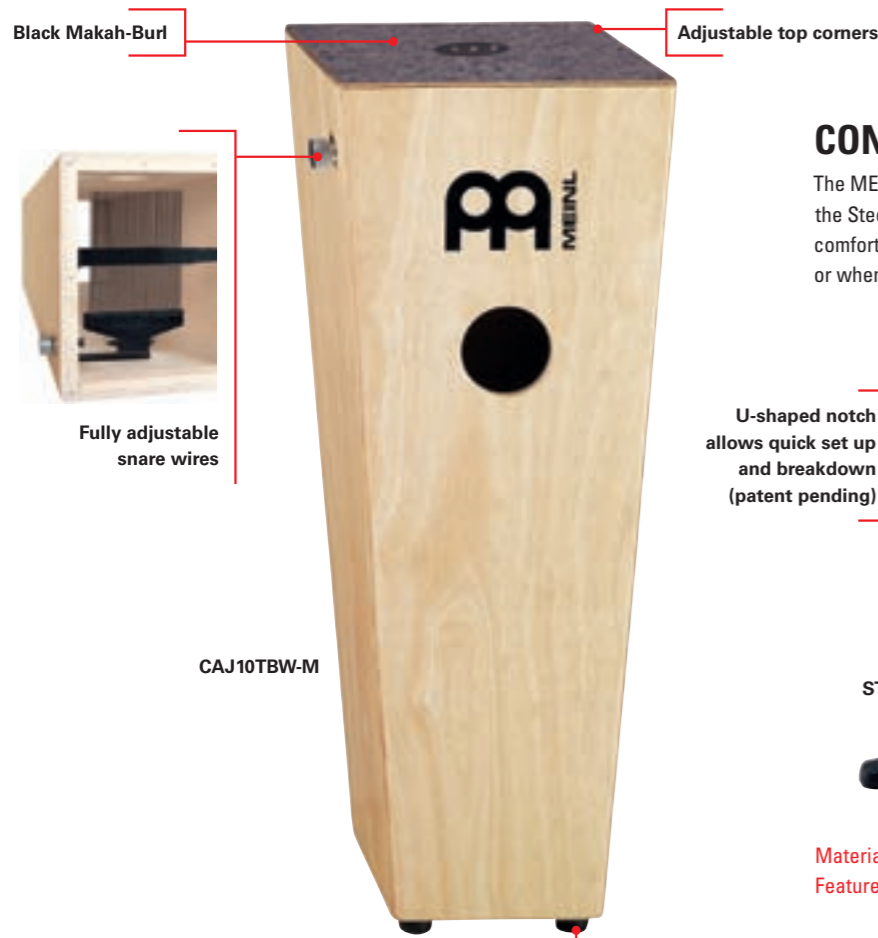

CAJ10TBW-M

## CONGA CAJON STAND

The MEINL Conga Cajon Stand has many of the same features as the Steely II Conga Stands (patented). It was designed to enable a comfortable placement of MEINL Conga Cajon when played by itself or when incorporating it into a percussion rig.

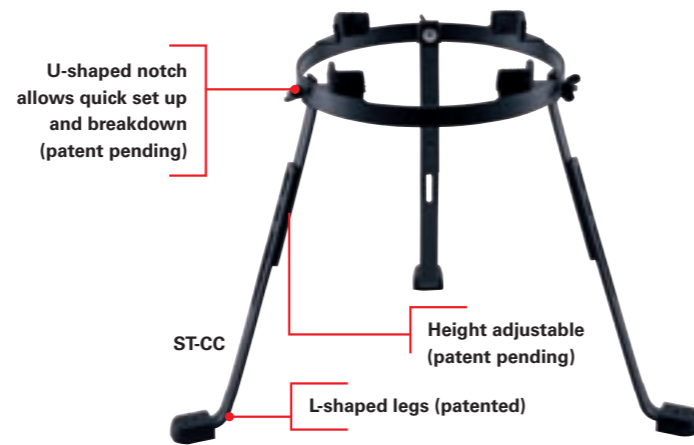

- Material** Black powder coated
- Features** Patented designs  
Metal spike attached to each leg  
L-shaped legs (patented)  
U-shaped notch for quick set up and breakdown  
Notches for quick height adjustability
- Includes** Allen wrench

- Materials** Playing surface: Black Makah-Burl  
Resonating Body: Rubber Wood (*Hevea brasiliensis* Muell.-Arg.)
- Features** Internal, adjustable snare wires  
Adjustable top corners
- Finish** Matte

Heavy duty rubber feet for a solid base

## BONGO CAJONS

The MEINL Bongo Cajon is uniquely different. It delivers the sound one can expect from a traditional cajon, and with a playing surface that has high- and low pitch sound areas, traditional bongo patterns can be played on it as well.

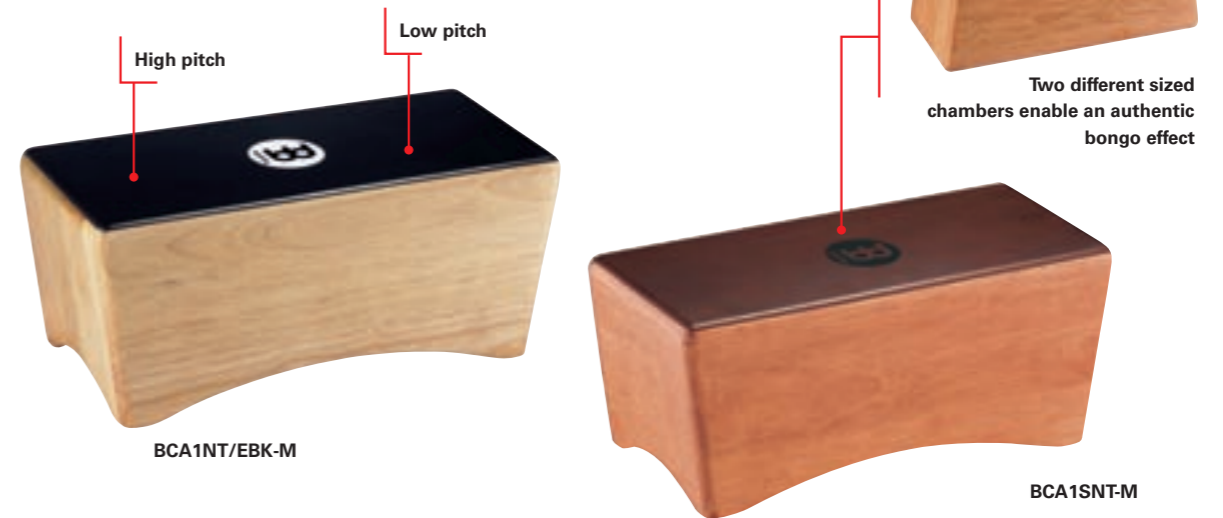

High pitch

Low pitch

Two different sized chambers enable an authentic bongo effect

BCA1NT/EBK-M

BCA1SNT-M

- Material** Rubber Wood (*Hevea brasiliensis* Muell.-Arg.)
- Features** High- and low pitch playing surface  
Compact size and light weight

- Colours** NT/EBK-M = Natural/Ebony Black  
SNT-M = Super Natural
- Finish** Matte

## TREJON



The MEINL Trejon is a breakthrough cajon development. Three separate faceplates create three distinct tonal effects. It is similar to a drum set in that bass, snare, and tom sounds are in easy reach on the comfortably angled playing surface. The Ebony faceplates are exotic and stylish.

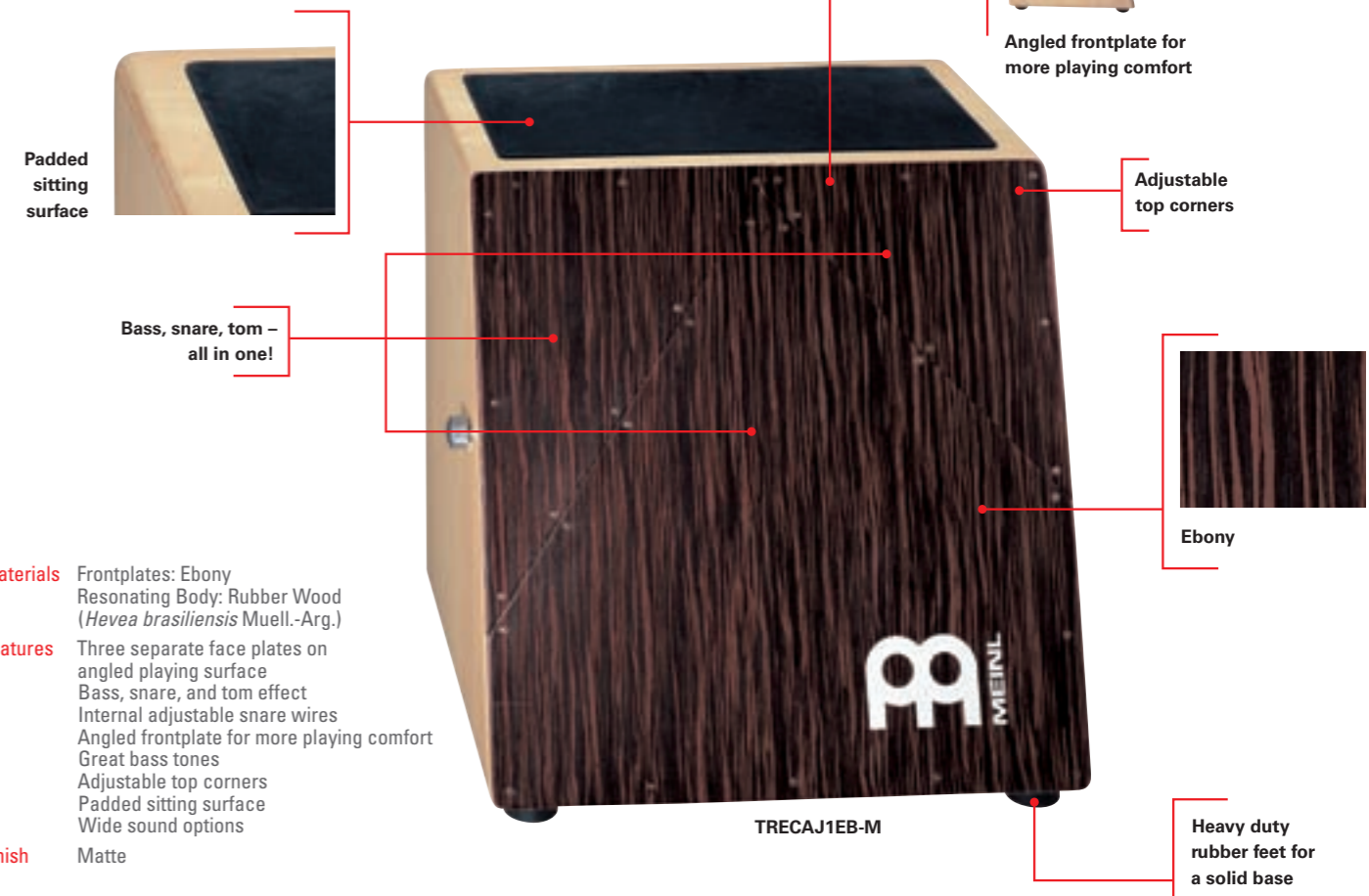

Padded sitting surface

Bass, snare, tom - all in one!

Angled frontplate for more playing comfort

Adjustable top corners

Ebony

Heavy duty rubber feet for a solid base

- Materials** Frontplates: Ebony  
Resonating Body: Rubber Wood (*Hevea brasiliensis* Muell.-Arg.)

- Features** Three separate face plates on angled playing surface  
Bass, snare, and tom effect  
Internal adjustable snare wires  
Angled frontplate for more playing comfort  
Great bass tones  
Adjustable top corners  
Padded sitting surface  
Wide sound options

- Finish** Matte

TRECAJ1EB-M



## DELUXE BASS PEDAL CAJON BAG

The MEINL Deluxe Cajon Bag for the CAJ5 is perfectly suited for the bigger sized Bass Pedal Cajon. It features an additional layer of synthetic fur, which removes surface moisture and provides additional protection.

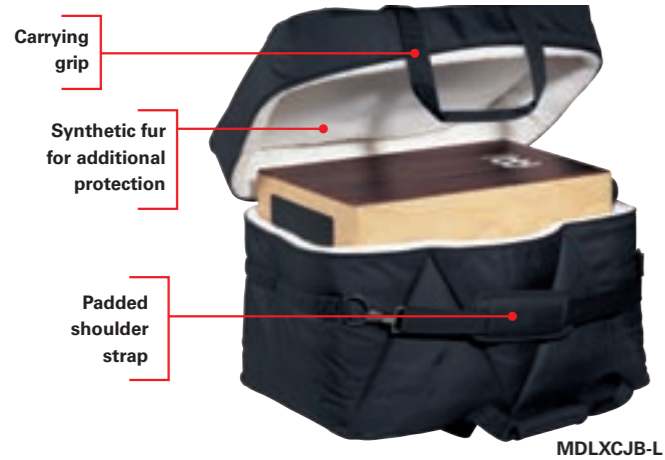

- Materials** Heavy duty padded nylon  
Synthetic fur
- Measures** 21 1/2" W x 17" H x 14 1/2" D
- Features** Padded shoulder strap  
External pocket  
Carrying grip

MDLXCJB-L

## DELUXE CAJON BAG

The MEINL Deluxe Cajon Bag features an additional layer of synthetic fur, which removes surface moisture and provides additional protection. Additional features are a padded shoulder strap and an external pocket for accessories.



- Materials** Heavy duty padded nylon  
Synthetic fur
- Measures** 20 1/2" W x 12" H x 12" D
- Features** Padded shoulder strap  
External pocket  
Carrying grip

MDLXCJB

## PROFESSIONAL CAJON BAG

The MEINL Cajon Bag is the perfect solution for transporting these valuable instruments. Its heavy duty padded outside walls store it securely and prevents damage.



- Material** Heavy duty padded nylon
- Measures** 20 1/2" W x 12" H x 12" D
- Features** Padded shoulder strap  
External pocket  
Carrying grip

MCJB

## PROFESSIONAL CONGA CAJON BAG

The Professional Conga Cajon Bag stores this valuable instrument securely and prevents it from being damaged during travel.



- Material** Heavy duty padded nylon
- Features** Padded shoulder strap  
External pocket  
Carrying grip

MCJB-D

## PROTECTION COVER FOR HEADLINER CAJON

**NEW**

The MEINL Protection Cover for Headliner Cajons offers dependable protection at an affordable price, assuring your cajon will look as good as it sounds for a long time to come.

- Material** Heavy duty nylon
- Colour** Black



MCJPC



## ERGO-SHAPE (patent pending)

MEINL's new ergonomically shaped frontplate has a slight curve that follows the natural contour of your hands for extreme comfort when playing cajon – you will feel the difference!

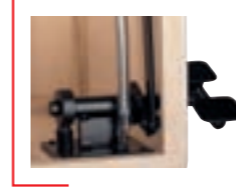

## FOOT PEDAL (patent pending)

The foot pedal features another unique innovation, which proves once again MEINL's leading R/D status in the worldwide percussion scene. A pedal attached to the cajon adjusts the amount of pressure used to press the snare wires against the front plate, and can even be turned off completely. This system allows the player to change the settings of the snare wires while playing a rhythm with both hands without interruption.



## FULLY ADJUSTABLE SNARE WIRES

To equip a cajon with fully adjustable snare wires is a MEINL innovation and proves yet again MEINL's leading R/D status in the worldwide percussion scene. The snares touch the frontplate from the inside and deliver the classical cajon sound, which is requisite in Flamenco music. A knurled knob adjusts the amount of pressure used to press the snares wires against the frontplate. Rattling ranging between light and sensitive to very loud can be achieved through adjustment. The entire snare unit can even be turned off completely.



## ADJUSTABLE SIZZLE EFFECT WITH INTEGRATED STRING MUTE SYSTEM (patent pending)

MEINL String Cajons feature an adjustable sizzle effect. Strings touch the frontplate on the inside and span from top to bottom, delivering a sensitive rattle that can be adjusted to fit various musical applications. The integrated string mute system controls the tension of the strings and ensures a dry and crisp sizzle effect.

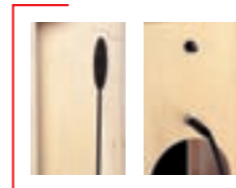

## PICKUP SYSTEM

The MEINL Pickup Cajons are equipped with the DST pickup microphone and the A1.2 pre-amp system with volume control from B-Band®. This active system includes a specially designed preamp, high quality endpin output jack and a durable battery. The structure is light in mass adding very little weight to the instrument. The sound reproduction is amazingly pure and clear.



## FIBERGLASS FRONTPLATE

MEINL is once again proving its leading position in utilizing new materials to create new sounds. Using premium fiberglass to construct the frontplate of a cajon not only offers a drastic new look, but also offers many new sound options which are not possible through the use of traditional materials.





**Rocco Horn,**  
composer and producer

**Jenny Kröning,**  
waitress

**Laura Hahn,**  
student

## DJEMBES

**Jenny Kröning:**

"Drumming really takes the edges off urban living. Lots of friends here in Berlin are getting into the drumming scene. It's energizing, it's primal, and it's fun!"



# ORIGINAL AFRICAN STYLE ROPE TUNED WOOD DJEMBES EARTH RHYTHM SERIES

**NEW**

The MEINL Original African Style Rope Tuned Wood Djembes are carved from one solid piece of plantation grown Mahogany Wood. These high quality instruments are crafted with great attention to detail and provide an outstanding, full voluminous sound. The Mali-Weave rope tuning system guarantees a proper and long-lasting tuning of the instrument. The Earth Rhythm Series features a carved design in black and brown. Its earthy pattern is evocative of ploughed fields and stalks of grain. The MEINL Original African Style Rope Tuned Djembes come bundled with the Professional Djembe Bag.

**COMES WITH BAG**

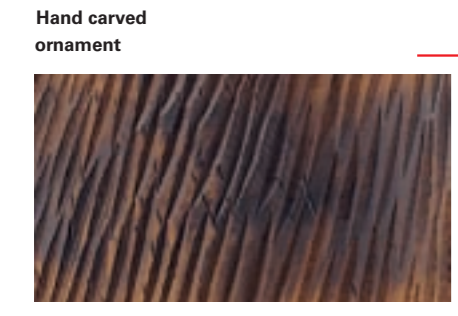

ADJ3-XL+BAG bundle with MDJB-M



ADJ3-L+BAG bundle with MDJB-M

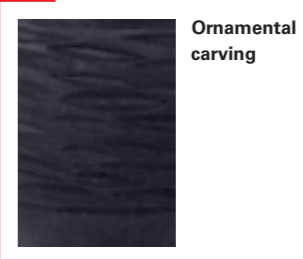

Carved from one solid piece of plantation grown Mahogany Wood



ADJ3-M+BAG bundle with MDJB-S

- Material** Mahogany Wood
- Features** Carved from one solid piece of plantation grown Mahogany Wood  
Hand selected goat heads  
Double braided HTP nylon ropes  
Hand carved shells  
Ornamental carving
- Includes** Professional Djembe Bag made out of heavy duty padded nylon
- Colour** Brown/Black

| Sizes    | Diameter          | Tall |
|----------|-------------------|------|
| M = 10"  | 9 1/4" – 10 1/4"  | 20"  |
| L = 12"  | 10 3/4" – 12 1/4" | 24"  |
| XL = 13" | 12 3/4" – 14 1/4" | 25"  |

| HTP rope | Thickness | Runners |
|----------|-----------|---------|
| M        | 4 mm      | 25      |
| L        | 4 mm      | 35      |
| XL       | 5 mm      | 35      |

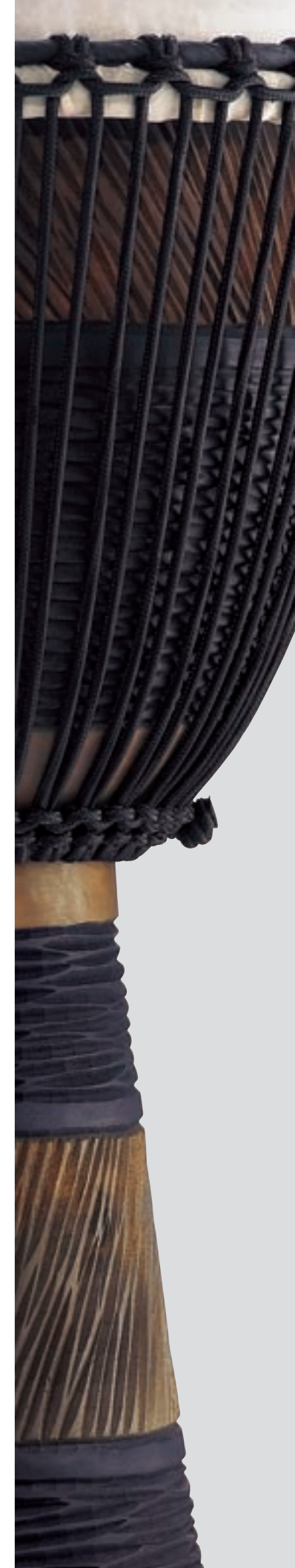



## ORIGINAL AFRICAN STYLE ROPE TUNED WOOD DJEMBES MOON RHYTHM SERIES

The MEINL Original African Style Rope Tuned Wood Djembes are carved from one solid piece of plantation grown Mahogany Wood. These high quality instruments are crafted with great attention to detail and provide an outstanding, full voluminous sound. The Mali-Weave rope tuning system guarantees a proper and long-lasting tuning of the instrument. The Moon Rhythm Series features a carved design in a dark mystic finish. The MEINL Original African Style Rope Tuned Djembes come bundled with the Professional Djembe Bag.

**NEW**

**COMES WITH BAG**

Hand carved ornament



ADJ4-XL+BAG  
bundle with MDJB-M

- Material** Mahogany Wood
- Features** Carved from one solid piece of plantation grown Mahogany Wood  
Hand selected goat heads  
Double braided HTP nylon ropes  
Hand carved shells  
Ornamental carving
- Includes** Professional Djembe Bag made out of heavy duty padded nylon
- Colour** Black



ADJ4-M+BAG  
bundle with MDJB-S



ADJ4-L+BAG  
bundle with MDJB-M

Pre-stretched high quality HTP nylon rope



| Sizes    | Diameter          | Tall |
|----------|-------------------|------|
| M = 10"  | 9 1/4" – 10 1/4"  | 20"  |
| L = 12"  | 10 3/4" – 12 1/4" | 24"  |
| XL = 13" | 12 3/4" – 14 1/4" | 25"  |

| HTP rope | Thickness | Runners |
|----------|-----------|---------|
| M        | 4 mm      | 25      |
| L        | 4 mm      | 35      |
| XL       | 5 mm      | 35      |





## ORIGINAL AFRICAN STYLE ROPE TUNED WOOD DJEMBES WATER RHYTHM SERIES

The MEINL Original African Style Rope Tuned Wood Djembes are carved from one solid piece of plantation grown Mahogany Wood. These high quality instruments are crafted with great attention to detail and provide an outstanding, full voluminous sound. The Mali-Weave rope tuning system guarantees a proper and long long-lasting tuning of the instrument. The Water Rhythm Series features a carved design evocative of ocean waves, and all djembes come bundled with the Professional Djembe Bag.

**COMES WITH BAG**

- Material** Mahogany Wood
- Features** Carved from one solid piece of plantation grown Mahogany Wood  
Hand selected goat heads  
Double braided HTP nylon ropes  
Hand carved shells
- Includes** Professional Djembe Bag made out of heavy duty padded nylon
- Colour** Brown

Hand selected goat head

Pre-stretched high quality HTP nylon rope



ADJ2-XL+BAG bundle with MDJB-M



Hand carved ornament



ADJ2-L+BAG bundle with MDJB-M

Carved from one solid piece of plantation grown Mahogany Wood



ADJ2-M+BAG bundle with MDJB-S



| Sizes    | Diameter          | Tall |
|----------|-------------------|------|
| M = 10"  | 9 1/4" - 10 1/4"  | 20"  |
| L = 12"  | 10 3/4" - 12 1/4" | 24"  |
| XL = 13" | 12 3/4" - 14 1/4" | 25"  |

| HTP rope | Thickness | Runners |
|----------|-----------|---------|
| M        | 4 mm      | 25      |
| L        | 4 mm      | 35      |
| XL       | 5 mm      | 35      |

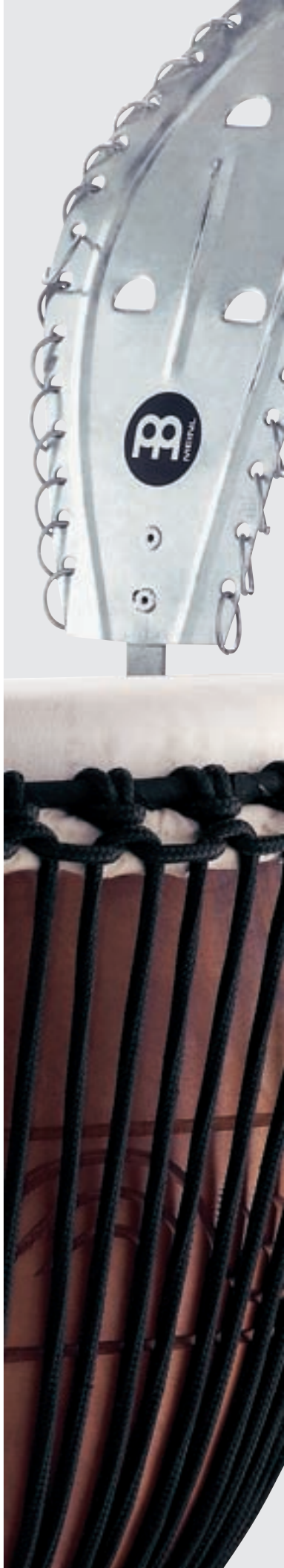



## ROPE TUNED WOOD DJEMBES

The MEINL Rope Tuned Wood Djembes are crafted with great attention to detail. They feature the traditional rope tuning system. A great sounding drum at an affordable price.



DJWR3AB-M

DJWR3SNT-M

DJWR3NT-M

**Size** 12"  
24 1/4" tall  
**Material** Rubber Wood  
(*Hevea brasiliensis* Muell.-Arg.)  
**Features** True Skin Calf Heads  
Traditional rope tuning system

**Colours** AB-M = African Brown  
NT-M = Natural  
SNT-M = Super Natural  
**Finish** Matte



Traditional rope tuning system

## HEADLINER® SERIES WOOD DJEMBES

If you are looking for an affordable djembe for drum circles or spontaneous jam sessions, don't look any further! The MEINL Headliner® Series Djembes have it all! Equipped with hand selected goat heads, they produce the classic djembe sounds reaching from fat basses to rich open tones and cutting slaps.



All djembes are equipped with six tuning lugs for better tuning consistency

Black powder coated 2 mm rounded rim



HDJ600WRB

HDJ600MA

HDJ600VSB

HDJ600NT

Original MEINL style tuning bracket



Rubber ringed bottom for more stability and protection

**Size** 12"  
23 1/2" tall  
**Material** Rubber Wood  
(*Hevea brasiliensis* Muell.-Arg.)  
**Features** 8 mm strong tuning lugs  
2 mm rounded rims  
Original MEINL style tuning brackets  
Black powder coated hardware  
Hand selected goat heads

**Includes** Tuning key  
**Colours** MA = Maple  
NT = Natural  
VSB = Vintage Sunburst  
WRB = Wine Red Burst  
**Finish** Hi Gloss





## FLOATUNE SERIES 12 3/4" WOOD DJEMBES

The 12 3/4" MEINL Floatune Djembe is modeled after the West African originals. Deep, round-sounding bass notes complimented by crisp tones and slaps are produced by this drum. The djembe is a popular drum known for its dynamic sounds, and the most widely used African drum today.



**Size** 12 3/4"  
25 1/4" tall

**Material** Rubber Wood  
(*Hevea brasiliensis* Muell.-Arg.)

**Features** True Skin Goat Heads  
8 mm strong tuning lugs  
3 mm rounded SSR-Rims  
Easy tuning and comfortable change of heads  
Rubber pads and lug placement offer perfect playing comfort  
Floatune Tuning System  
Chrome plated hardware

**Includes** Accessory pouch  
L-shaped tuning key  
Tune Up Oil

**Colours** AB-M = African Brown, matte  
GAB-M = Gold Amber Sunburst, matte  
NT = Natural, hi gloss  
SNT-M = Super Natural, matte

**NEW**

The head can be tuned very simply

## FLOATUNE SERIES 12" WOOD DJEMBES

The 12" MEINL Floatune Djembe is modeled after the West African originals. The proportions of this drum provide higher, brighter tones and slaps, while retaining a clear, full bass note. This model is a bit more compact and lighter in weight.



**Size** 12"  
24 1/4" tall

**Material** Rubber Wood  
(*Hevea brasiliensis* Muell.-Arg.)

**Features** True Skin Goat Heads  
8 mm strong tuning lugs  
3 mm rounded SSR-Rims  
Easy tuning and comfortable change of heads  
Rubber pads and lug placement offer perfect playing comfort  
Floatune Tuning System  
Chrome plated hardware

**Includes** Accessory pouch  
L-shaped tuning key  
Tune Up Oil

**Colours** AB-M = African Brown, matte  
GAB-M = Gold Amber Sunburst, matte  
NT = Natural, hi gloss  
SNT-M = Super Natural, matte

**NEW**





## FLOATUNE SERIES WOOD DJEMBE

The MEINL Floatune Wood Djembe is made from finest American White Ash (*Fraxinus americana* L.) which produces an excellent voluminous djembe sound.



- Size** 12"  
24 1/4" tall
- Material** American White Ash (*Fraxinus americana* L.)
- Features** True Skin Goat Head  
8 mm strong tuning lugs  
3 mm rounded SSR-Rim  
Easy tuning and comfortable change of heads  
Rubber pads and relocated lugs offer perfect playing comfort  
Floatune Tuning System  
Chrome plated Hardware
- Includes** Accessory pouch  
L-shaped tuning key  
Tune Up Oil
- Colour** ZFA-M = Zebra Finished Ash
- Finish** Matte

## FLOATUNE SERIES FIBERGLASS DJEMBES

The MEINL Floatune Series Fiberglass Djembes are truly a sound alternative. Fiberglass has enormous strength and can produce slaps of outstanding clarity and immensely powerful bass tones.



- Size** 12"  
24 1/4" tall
- Material** Premium fiberglass
- Features** True Skin Goat Heads  
8 mm strong tuning lugs  
3 mm rounded SSR-Rims  
Easy tuning and comfortable change of heads  
Rubber pads and lug placement offer perfect playing comfort  
Floatune Tuning System  
Chrome plated hardware
- Includes** Accessory pouch  
L-shaped tuning key  
Tune Up Oil
- Colours** BSP = Blue Sparkle  
RSP = Red Sparkle





## STEELY II DJEMBE STAND (patented)

The Steely II Djembe stand (patented) features all of the same designs as the Steely II Conga stands (patented). It can be adjusted to accommodate various djembe sizes using three spacers and is fully height adjustable. It is perfect for drum circles and other street percussion activities.

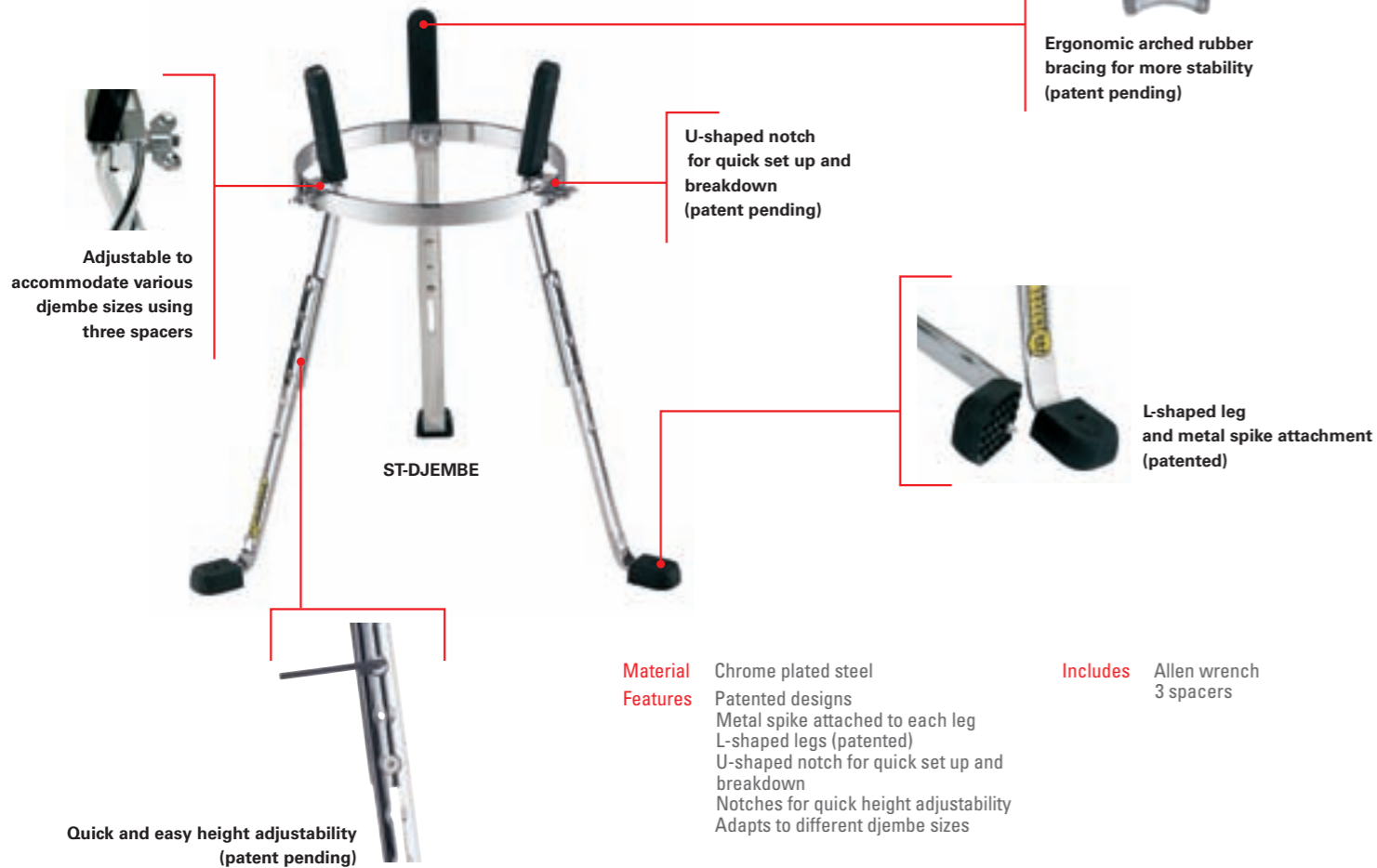

**Material** Chrome plated steel  
**Features** Patented designs  
 Metal spike attached to each leg  
 L-shaped legs (patented)  
 U-shaped notch for quick set up and breakdown  
 Notches for quick height adjustability  
 Adapts to different djembe sizes

**Includes** Allen wrench  
 3 spacers

## KESSING

The Kessing is a traditional djembe accessory that provides a dry rattling accompaniment to the drum. It slides securely into the webbing and is removable.

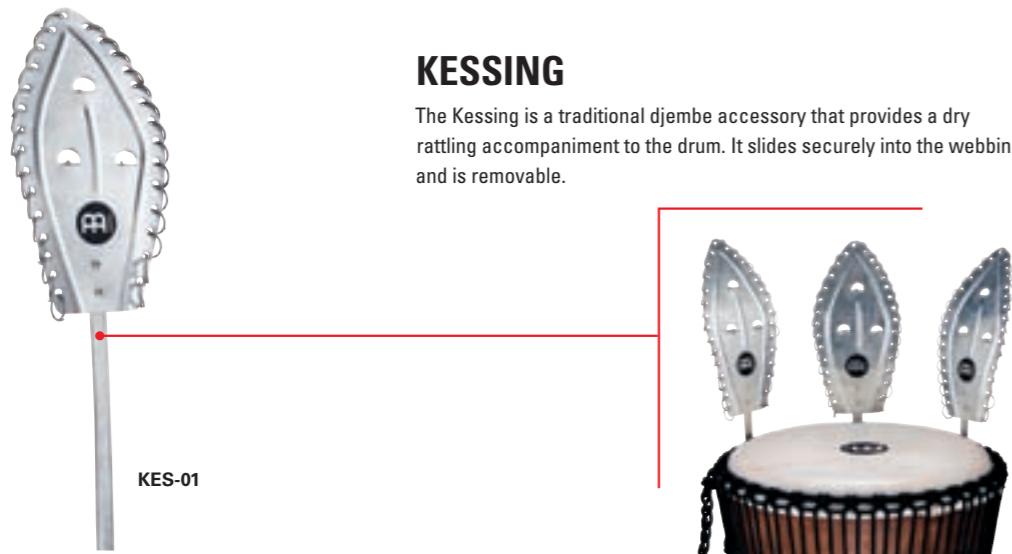

**Size** Medium  
**Material** Aluminum

Example with three kessings

## PROFESSIONAL DJEMBE STAND

The MEINL Djembe Stand was designed to firmly hold any djembe in the traditional playing position. A nylon strap is secured around the drum and two rubber padded u-shaped hooks slide into the bottom of the shell. It can be angled, and is fully height adjustable.

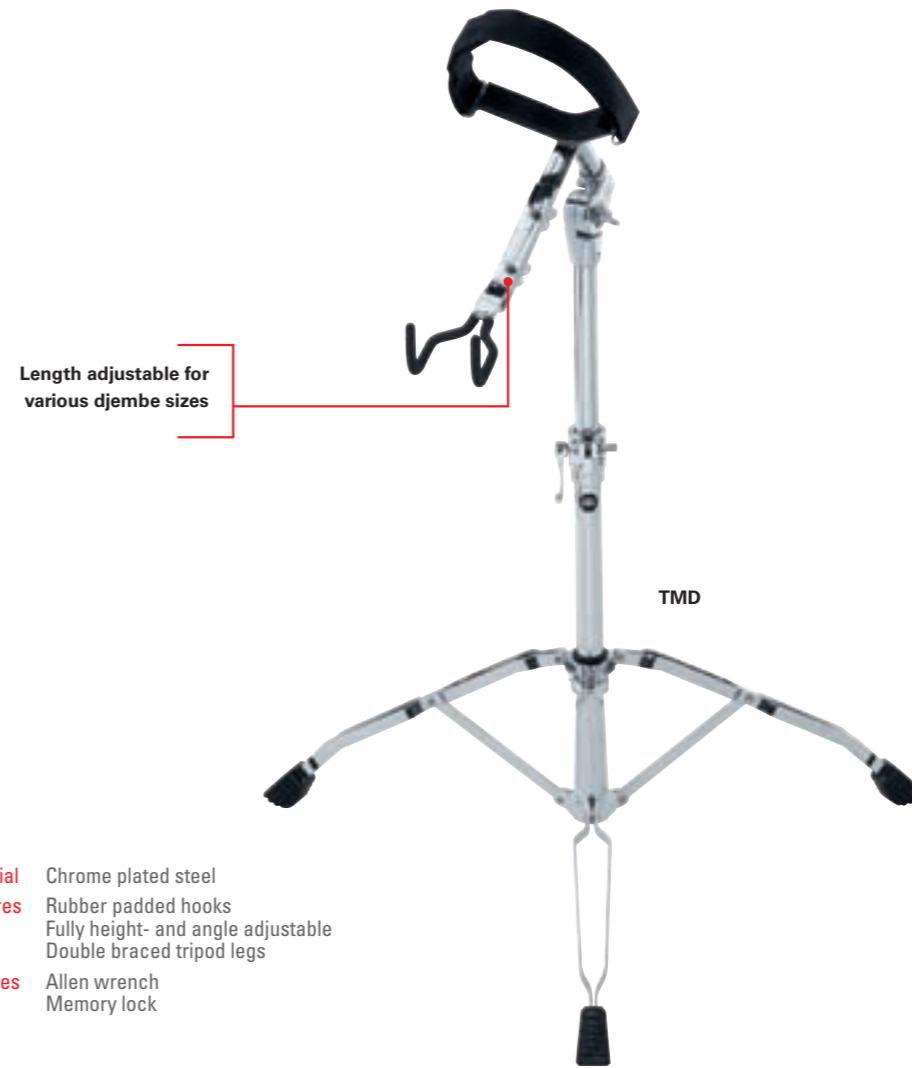

**Material** Chrome plated steel  
**Features** Rubber padded hooks  
 Fully height- and angle adjustable  
 Double braced tripod legs  
**Includes** Allen wrench  
 Memory lock

## PROFESSIONAL DJEMBE STRAP

The MEINL Djembe Strap comfortably and securely holds any djembe in the perfect playing position. It is fully adjustable and works on all common djembes. Thick pads ensure long lasting comfort while playing.



**Material** Cloth-covered nylon  
**Features** Quick change hook  
 Adjustable straps  
 Quick-release buckles  
**Colour** Multi colour

MDJS1



## PROFESSIONAL DJEMBE BAGS

The MEINL Djembe Bags come in two sizes, medium and large, to fit all common djembe models. Additional features are padded backpack straps and an external pocket for accessories.



Carrying grip

Padded backpack strap

- Sizes** Medium (up to 12")  
Large (up to 13 1/2")
- Material** Heavy duty padded nylon
- Features** External pocket  
Padded backpack straps  
Carrying grip
- Compatibility** MDJB-M:  
DJW3, DJF3, DJWR3, HDJ600  
MDJB-L:  
DJW2

MDJB-M



MDJB-L

## DELUXE DJEMBE BAGS

The MEINL Deluxe Djembe Bags feature an additional layer of synthetic fur, which removes surface moisture and provides additional protection. They come in medium and large sizes enabling them to fit all common djembe models. Additional features are padded backpack straps and an external pocket for accessories.



MDLXDB-M



Synthetic fur for additional protection

- Sizes** Medium (up to 12")  
Large (up to 13 1/2")
- Materials** Heavy duty padded nylon  
Synthetic fur
- Features** External pocket  
Padded backpack straps  
Carrying grip
- Compatibility** MDLXDB-M:  
DJW3, DJF3, DJWR3, HDJ600  
MDLXDB-L:  
DJW2



MDLXDB-L

## DJEMBES

| Model No.  | Size              | Height  | Material | Features | SPARE PARTS |         |        |              |       |
|--|-------------------|---------|----------|----------|-------------|---------|--------|--------------|-------|
|  |                   |         |          |          | Head        | Rim     | Lug    | Bracket      | Page  |
| <b>ORIGINAL AFRICAN STYLE ROPE TUNED WOOD DJEMBE WATER RHYTHM SERIES</b> |                   |         |          |          |             |         |        |              |       |
| ADJ2-M+BAG   | 9 1/4" - 10 1/4"  | 20"     | •        | •        | HEAD-53     |         |        |              | 25    |
| ADJ2-L+BAG   | 10 3/4" - 12 1/4" | 24"     | •        | •        | HEAD-54     |         |        |              | 25    |
| ADJ2-XL+BAG  | 12 3/4" - 14 1/4" | 25"     | •        | •        | HEAD-55     |         |        |              | 24    |
| <b>ORIGINAL AFRICAN STYLE ROPE TUNED WOOD DJEMBE EARTH RHYTHM SERIES</b> |                   |         |          |          |             |         |        |              |       |
| ADJ3-M+BAG   | 9 1/4" - 10 1/4"  | 20"     | •        | •        | HEAD-53     |         |        |              | 21    |
| ADJ3-L+BAG   | 10 3/4" - 12 1/4" | 24"     | •        | •        | HEAD-54     |         |        |              | 21    |
| ADJ3-XL+BAG  | 12 3/4" - 14 1/4" | 25"     | •        | •        | HEAD-55     |         |        |              | 20    |
| <b>ORIGINAL AFRICAN STYLE ROPE TUNED WOOD DJEMBE EARTH RHYTHM SERIES</b> |                   |         |          |          |             |         |        |              |       |
| ADJ4-M+BAG   | 9 1/4" - 10 1/4"  | 20"     | •        | •        | HEAD-53     |         |        |              | 23    |
| ADJ4-L+BAG   | 10 3/4" - 12 1/4" | 24"     | •        | •        | HEAD-54     |         |        |              | 23    |
| ADJ4-XL+BAG  | 12 3/4" - 14 1/4" | 25"     | •        | •        | HEAD-55     |         |        |              | 22    |
| <b>HEADLINER® SERIES WOOD DJEMBES</b>                                    |                   |         |          |          |             |         |        |              |       |
| HDJ600   | 12"               | 23 1/2" | •        |          | HHEAD12W    | HRIM12W | HDLUGW | HDBRACKET-02 | 27    |
| <b>ROPE TUNED WOOD DJEMBES</b>   |                   |         |          |          |             |         |        |              |       |
| DJWR3  | 12"               | 24 1/4" | •        | •        | TS-CA-01    |         |        |              | 26    |
| <b>FLOATUNE SERIES 12 3/4" WOOD DJEMBES</b>                              |                   |         |          |          |             |         |        |              |       |
| DJW2   | 12 3/4"           | 25 1/4" | •        | •        | TS-G-02     | SSR-30  | LUG-04 |              | 28    |
| <b>FLOATUNE SERIES 12" WOOD DJEMBES</b>                                  |                   |         |          |          |             |         |        |              |       |
| DJW3   | 12"               | 24 1/4" | •        | •        | TS-G-01     | SSR-29  | LUG-04 |              | 29/30 |
| <b>FLOATUNE SERIES FIBERGLASS DJEMBES</b>                                |                   |         |          |          |             |         |        |              |       |
| DJF3   | 12"               | 24 1/4" | •        | •        | TS-G-01     | SSR-29  | LUG-05 |              | 31    |
| <b>SPARE PARTS FOR STANDS</b>  |                   |         |          |          |             |         |        |              |       |
| Rubber Feet (set of 3 pcs.) for Steely-II Stand                          |                   |         |          |          | STAND-35    |         |        |              | 32    |
| Rubber Tops (set of 3 pcs.) for Steely-II Stand                          |                   |         |          |          | STAND-21    |         |        |              | 32    |
| Socket Screw (set of 2 pcs.) chrome                                      |                   |         |          |          | STAND-27    |         |        |              | 32    |
| Fast Lock Set, chrome  |                   |         |          |          | STAND-14    |         |        |              | 33    |
| Rubber Feet (set of 3 pcs.) for Djembe Stand                             |                   |         |          |          | STAND-16    |         |        |              | 33    |
| <b>OTHER PARTS</b>   |                   |         |          |          |             |         |        |              |       |
| Lug Oil  |                   |         |          |          | SPARE-09    |         |        |              |       |
| Tuning Key, 13mm + 14mm, L-shaped, chrome                                |                   |         |          |          | KEY-02      |         |        |              |       |

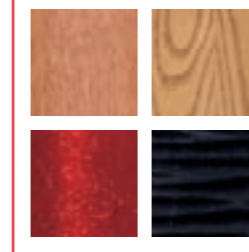

### DIVERSITY IN MATERIALS

MEINL uses four different materials to produce premium djembes: Rubber Wood (*Hevea brasiliensis* Muell.-Arg.), American White Ash (*Fraxinus americana* L.), premium fiberglass, and plantation grown Mahogany Wood. This diversity covers all djembe sounds ever required in any musical setting.



### MALI-WEAVE ROPE TUNING SYSTEM

The complex rope tuning system guarantees an ideal and long lasting tuning of the instrument, with the HTP nylon rope that is used being of the highest standard.



### TRUE SKIN GOAT HEADS

The original MEINL True Skin Goat Heads on djembes offer the widest dynamic range from cutting slaps to powerful bass tones. True Skin hides are selected by specialists. After the selection process, each skin is gently tanned using a special MEINL procedure and then mounted by hand to become a first class True Skin Head.







## CONGAS

### MIPA AWARD FOR MEINL PROFESSIONAL SERIES AND MEINL ARTIST SERIES LUIS CONTE CONGAS

The "Musikmesse International Press Award" is annually presented by 55 music magazines from all over the world that get together and vote for the best products in certain categories.

In the category "Best Percussion Product," MEINL Congas have won the MIPA Award twice.





## WOODCRAFT SERIES

The MEINL Woodcraft Series Congas stand for tradition combined with exceptional workmanship. Only the finest hand selected materials are used to produce these premium drums. Their "Cuban Style" shells provide a broad range of different tonal characteristics.



Chrome plated 4 mm traditional TTR-Rim



Gold tone 4 mm rounded SSR-Rim



**Sizes** 11" Quinto, 11 3/4" Conga, 12 1/2" Tumba 30" tall  
**Material** Two ply American White Ash (*Fraxinus americana* L.)  
**Features** True Skin Buffalo Heads  
 10 mm strong tuning lugs  
 4 mm traditional TTR-Rims  
 Chrome plated hardware

**Includes** MEINL Conga Saver (patented)  
 MEINL Soundpads  
 Accessory pouch  
 L-shaped tuning key  
 Tune Up Oil  
**Colour** ZFA-M = Zebra Finished Ash  
**Finish** Matte

Traditional, "Cuban Style" shell for enhanced volume

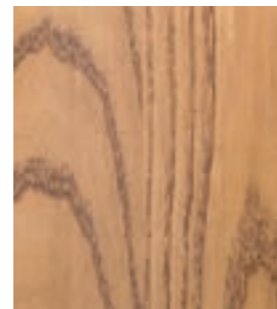

Two ply American White Ash (*Fraxinus americana* L.)

## ARTIST SERIES

*Mongo Santamaria*

Ramon "Mongo" Santamaria was without a doubt one of the most respected conga players ever and a pioneer of modern Latin Jazz. During the 50's his band "Black Cuban Diamonds" laid down the foundation for an outstanding career.

He has recorded dozens of legendary percussion albums. Worldwide Jazz hits, such as "Watermelon Man" in 1963 and the album "Summertime" from 1980 are only two of the many recordings from this great master percussionist. Mongo has inspired more percussionists around the globe than any other conguero.

Mongo Santamaria died at the Baptist Hospital in Miami, USA in February 2003. He was 85 years old. It is with great appreciation and deepest respect that we honour our friend and his life's work with his MEINL Artist Series Mongo Santamaria Congas.



Ramon "Mongo" Santamaria, Cuba



**Sizes** 11" Quinto, 11 3/4" Conga, 12 1/2" Tumba 30" tall  
**Material** Two ply American White Ash (*Fraxinus americana* L.)  
**Features** True Skin Buffalo Heads  
 10 mm strong tuning lugs  
 4 mm rounded SSR-Rims  
 Gold tone hardware

**Includes** MEINL Conga Saver (patented)  
 MEINL Soundpads  
 Accessory pouch  
 L-shaped tuning key  
 Tune Up Oil  
**Colour** AWA = American White Ash  
**Finish** Hi Gloss



Two ply American White Ash (*Fraxinus americana* L.)





## FLOATUNE SERIES

**NEW**

The MEINL Floatune Tuning System is a true and unique MEINL innovation. All mounting hardware is completely isolated from the shell. This avoids the need to drill through the shell and mount hardware with bolts, which reduces the resonant vibrations of the shell. The Floatune Tuning System tunes up just like lug-equipped congas, only with an improved sound.



**Sizes** 10" Nino, 11" Quinto, 12" Conga, 13" Tumba 30" tall  
**Material** Two ply Rubber Wood (Hevea brasiliensis Muell.-Arg.)  
**Features** Floatune Tuning System  
 True Skin Buffalo Heads  
 10 mm strong tuning lugs  
 4 mm rounded SSR-Rims  
 Chrome plated hardware

**Includes** MEINL Conga Saver (patented)  
 MEINL Soundpads  
 Accessory pouch  
 L-shaped tuning key  
 Tune Up Oil  
**Colour** BB = Brown Burl  
**Finish** Hi Gloss

## 30<sup>TH</sup> ANNIVERSARY EDITION FIBERCRAFT SERIES

**NEW**

The MEINL 30<sup>TH</sup> Anniversary Fibercraft Conga is a dazzling special edition in a silver-chrome finish. These fiberglass congas are a real eye catcher, and are absolutely breath-taking under the lights onstage.



**Sizes** 11" Quinto, 11 3/4" Conga, 12 1/2" Tumba 30" tall  
**Material** Premium fiberglass  
**Features** True Skin Buffalo Heads  
 10 mm strong tuning lugs  
 4 mm rounded SSR-Rims  
 Chrome plated hardware

**Includes** MEINL Conga Saver (patented)  
 MEINL Soundpads  
 Accessory pouch  
 L-shaped tuning key  
 Tune Up Oil  
**Colour** CH = Chrome





## FIBERCRAFT SERIES

MEINL Fibercraft Congas offer great quality, durability, volume, and they resist to climatic changes. They have a great presence and brilliance in sound. Great for live playing and extensive road use.



Extraordinary sparkling effect

**Sizes** 11" Quinto, 11 3/4" Conga, 12 1/2" Tumba  
30" tall

**Material** Premium fiberglass

**Features** True Skin Buffalo Heads  
10 mm strong tuning lugs  
4 mm rounded SSR-Rims  
Chrome plated hardware

**Includes** MEINL Conga Saver (patented)  
MEINL Soundpads  
Accessory pouch  
L-shaped tuning key  
Tune Up Oil

**Colours** BKSP = Black Sparkle  
BSP = Blue Sparkle  
RSP = Red Sparkle



MEINL CONGA SAVER PATENTED





# PROFESSIONAL SERIES

*Roland Stein*

The Roland Meinl Professional Series Congas – one of the finest instruments in the MEINL Percussion program and the preferred conga model by many top congueros. Outstanding in look and sound, they reach from fat basses to cutting slaps with a great warm overall tone. They set the standard in the professional conga ranges.



MP11NT

MP1134NT

MP1212NT



Chrome plated 4 mm rounded SSR-Rim



MP11ARF

MP1134ARF

MP1212ARF



MP11BB

MP1134BB

MP1212BB



MP11EBK

MP1134EBK

MP1212EBK

**Sizes** 11" Quinto, 11 3/4" Conga, 12 1/2" Tumba  
30" tall

**Material** Two ply Rubber Wood  
(*Hevea brasiliensis* Muell.-Arg.)

**Features** True Skin Buffalo Heads  
10 mm strong tuning lugs  
4 mm rounded SSR-Rims  
Chrome plated hardware

**Includes** MEINL Conga Saver (patented)  
MEINL Soundpads  
Accessory pouch  
L-shaped tuning key  
Tune Up Oil

**Colours** ARF = Aztec Red Fade  
BB = Brown Burl  
EBK = Ebony Black  
NT = Natural

**Finish** Hi Gloss







## ARTIST SERIES *Luis Conte*

All of Luis' needs have been met and exceeded with the MEINL Artist Series Luis Conte Signature Congas. They combine the charm and sound of the old traditional Cuban drums with modern features and innovations. These congas are equipped with traditional rims, are mounted as close to the shell as possible, and when combined with MEINL's True Skin Buffalo Heads, they enable an even more controlled sound.



Black powder coated  
4 mm traditional TTR-Rim



LC11NT-M

LC1134NT-M

LC1212NT-M

Rubber ringed bottom  
for more stability and  
protection

- |                 |   |                 |  |
|-----------------|---|-----------------|--|
| <b>Sizes</b>    | 11" Quinto, 11 3/4" Conga, 12 1/2" Tumba<br>30" tall  | <b>Includes</b> | MEINL Conga Saver (patented)<br>MEINL Soundpads<br>Accessory pouch<br>L-shaped tuning key<br>Tune Up Oil |
| <b>Material</b> | Two ply Rubber Wood<br>( <i>Hevea brasiliensis</i> Muell.-Arg.)   | <b>Colour</b>   | NT-M = Natural   |
| <b>Features</b> | True Skin Buffalo Heads<br>8 mm strong tuning lugs<br>4 mm traditional TTR-Rims<br>Black powder coated hardware | <b>Finish</b>   | Matte  |





## 30<sup>TH</sup> ANNIVERSARY EDITION MARATHON® CLASSIC SERIES

The MEINL Marathon® Classic Series Congas are the benchmark by which other congas are judged. With MEINL Percussion celebrating its 30<sup>TH</sup> anniversary, we are proud to commemorate the occasion with the MEINL 30<sup>TH</sup> Anniversary Marathon® Classic Congas. This series comes in a stunning new Leopard Burl finish in hi gloss, has professional features and is available at a very attractive price.

**NEW**

SSR Safe & Sound Rim

Black powder coated  
2.6 mm rounded  
SSR-Rim

True Skin Buffalo Heads

30<sup>TH</sup> ANNIVERSARY EDITION

CONGA SAVER

Gorgeous leopard burl finish

MCC11LB

MCC1134LB

MCC1212LB



Ergonomic arched rubber bracing for more stability (patent pending)

STEELY-II CONGA STAND

- Sizes** 11" Quinto, 11 3/4" Conga, 12 1/2" Tumba 30" tall
- Material** Two ply Rubber Wood (*Hevea brasiliensis* Muell.-Arg.)
- Features** True Skin Buffalo Heads  
8 mm strong tuning lugs  
2.6 mm rounded SSR-Rims  
Black powder coated hardware
- Includes** Steely II Conga Stand (patented)  
MEINL Conga Saver (patented)  
Accessory pouch  
L-shaped tuning key  
Tune Up Oil
- Colour** LB = Leopard Burl
- Finish** Hi Gloss





## MARATHON® CLASSIC SERIES

The MEINL Marathon® Classic Series Congas set the standard in this price range by which other wood congas are judged. They combine professional features at a very attractive price.



Black powder coated  
2.6 mm rounded  
SSR-Rim



MCC11SNT-M

MCC1134SNT-M

MCC1212SNT-M

**Sizes** 11" Quinto, 11 3/4" Conga, 12 1/2" Tumba  
30" tall

**Material** Two ply Rubber Wood  
(*Hevea brasiliensis* Muell.-Arg.)

**Features** True Skin Buffalo Heads  
8 mm strong tuning lugs  
2.6 mm rounded SSR-Rims  
Black powder coated hardware

**Includes** Steely II Conga Stand (patented)  
MEINL Conga Saver (patented)  
Accessory pouch  
L-shaped tuning key  
Tune Up Oil

**Colours** CB = Coffee Burst, hi gloss  
SNT-M = Super Natural, matte  
TSR-M = Tequilla Sunrise, matte



Ergonomic  
arched rubber bracing  
for more stability  
(patent pending)



MCC11TSR-M

MCC1134TSR-M

MCC1212TSR-M



MCC11CB

MCC1134CB

MCC1212CB



## HEADLINER® SERIES

### 11" & 12" WOOD CONGA SETS

The 11" & 12" pair is a full-sized entry level conga set. They have superb projection, warm tones, light weight and features found on professional congas. They offer outstanding quality and great value in the budget price range. This is a pair of congas you will want to keep around as you develop your skills.



- Sizes** 11" & 12" Conga Set  
28" tall
- Material** Rubber Wood  
(*Hevea brasiliensis* Muell.-Arg.)
- Features** Hand selected buffalo heads  
8 mm strong tuning lugs  
Original MEINL style tuning brackets  
2 mm rounded rims  
Black powder coated hardware
- Includes** Height adjustable basket stands with quick set up system  
Tuning key
- Colours** MA = Maple  
NT = Natural  
PW = Pearl White  
VSB = Vintage Sunburst  
WRB = Wine Red Burst
- Finish** Hi Gloss





# HEADLINER® SERIES

## 10" & 11" WOOD CONGA SETS

The 10" & 11" pair is the perfect set of congas to get you started. The compact size is easy for young players to handle, light to carry, and has a full, rich sound. You can develop a full foundation of conga techniques and rhythms with these student-friendly drums.



- Sizes** 10" & 11" Conga Set  
28" tall
- Material** Rubber Wood  
(*Hevea brasiliensis* Muell.-Arg.)
- Features** Hand selected buffalo heads  
8 mm strong tuning lugs  
Original MEINL style tuning brackets  
2 mm rounded rims  
Black powder coated hardware
- Includes** Height adjustable basket stands with quick set up system  
Tuning key
- Colours** BK = Black  
NT = Natural  
VSB = Vintage Sunburst  
WRB = Wine Red Burst
- Finish** Hi Gloss





## STEELY II CONGA STANDS (patented)

The MEINL Steely II Conga Stands (patented) are available for all MEINL Professional Series Congas.

### MODELS:

For Marathon® Classic Series Congas  
For Luis Conte Artist Series Congas

|              |         |                     |
|--------------|---------|---------------------|
| ST-MCC11BK   | 11"     | Black powder coated |
| ST-MCC1134BK | 11 3/4" | Black powder coated |
| ST-MCC1212BK | 12 1/2" | Black powder coated |

For Floatune Series Congas

|           |     |               |
|-----------|-----|---------------|
| ST-FL10CH | 10" | Chrome plated |
| ST-FL11CH | 11" | Chrome plated |
| ST-FL12CH | 12" | Chrome plated |
| ST-FL13CH | 13" | Chrome plated |

For Professional Series Congas  
For Fibercraft Series Congas

|             |         |               |
|-------------|---------|---------------|
| ST-MP11CH   | 11"     | Chrome plated |
| ST-MP1134CH | 11 3/4" | Chrome plated |
| ST-MP1212CH | 12 1/2" | Chrome plated |

For Mongo Santamaria Artist Series Congas

|             |         |           |
|-------------|---------|-----------|
| ST-MSA11G   | 11"     | Gold tone |
| ST-MSA1134G | 11 3/4" | Gold tone |
| ST-MSA1212G | 12 1/2" | Gold tone |

For Woodcraft Series Congas

|             |         |               |
|-------------|---------|---------------|
| ST-WC11CH   | 11"     | Chrome plated |
| ST-WC1134CH | 11 3/4" | Chrome plated |
| ST-WC1212CH | 12 1/2" | Chrome plated |

- Material** Steel
- Features** Patented designs  
Metal spike attachment on each leg  
L-shaped legs  
U-shaped notch for quick set up and breakdown  
Notches for quick height adjustability
- Includes** Allen wrench

## STEELY II CONGA STAND HEIGHT EXPANDER SET (patent pending)

These innovative add-ons to the MEINL Steely II Conga Stands (patented) allow an easy and effective height extension, which provides a more comfortable playing position for taller congueros.

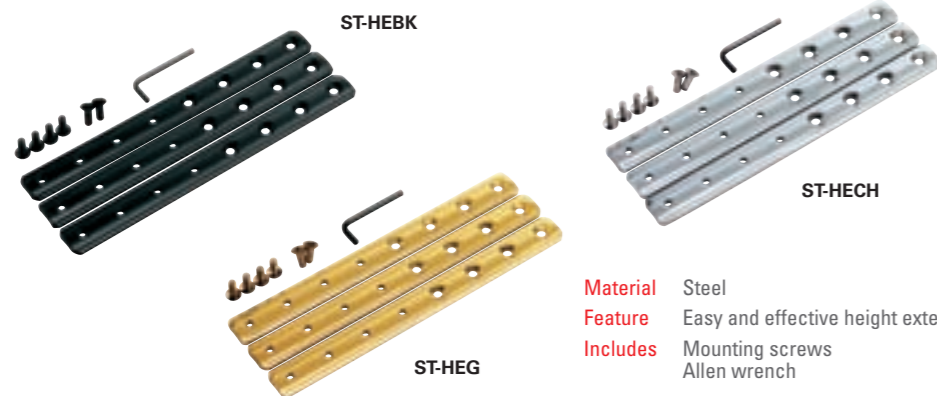

- Material** Steel
- Feature** Easy and effective height extension
- Includes** Mounting screws  
Allen wrench

Easy and effective height extension

- Finishes** Black powder coated  
Chrome plated  
Gold tone

U-shaped notch allows quick set up and breakdown (patent pending)

Ergonomic arched rubber bracing for more stability (patent pending)

L-shaped leg and metal spike attachment (patented)

Quick and easy height adjustability (patent pending)

## PROFESSIONAL CONGA STAND

The MEINL Conga Stand is unique with respect to design and function. It was especially developed to accommodate the rigors of professional road use, where fine adjustment and durability are demanded. It is fully height adjustable and securely fixed by means of the three legs of the stand.



The lightweight stand can be folded to a compact unit which requires little space

- Material** Chrome plated steel
- Features** Unique design  
Rubber padded crossbeams  
Fully height adjustable  
Folds up to a compact unit

- Includes** Allen wrench  
Memory locks

Compatible for all sizes



## PROFESSIONAL CONGA BAGS

The MEINL Conga Bags come in three sizes: Quinto, Conga, and Tumba. An additional upright zipper simplifies packing and unpacking of your drum. Additional features are padded backpack straps and an external pocket for accessories.



Additional upright zipper

- Sizes** 11"  
11 3/4"  
12 1/2"
- Material** Heavy duty padded nylon



Padded backpack strap

- Features** Additional upright zipper  
External pocket  
Padded backpack straps  
Carrying grip

Carrying grip



# CONGAS

| Model No.                                | Size      | Height | Material | Features | SPARE PARTS |     |     |                  |                | Page   |              |       |
|--|-----------|--------|----------|----------|-------------|-----|-----|------------------|----------------|--------|--------------|-------|
|  |           |        |          |          | Head        | Rim | Lug | Bracket          |                |        |              |       |
| <b>WOODCRAFT SERIES</b>                  |           |        |          |          |             |     |     |                  |                |        |              |       |
| WC11                                     | 11"       | 30"    | •        | •        | •           | •   | •   | TS-B-44          | TTR-23         | LUG-01 | BRACKET-14   | 38    |
| WC1134                                   | 11 3/4"   | 30"    | •        | •        | •           | •   | •   | TS-B-45          | TTR-24         | LUG-01 | BRACKET-14   | 38    |
| WC1212                                   | 12 1/2"   | 30"    | •        | •        | •           | •   | •   | TS-B-46          | TTR-25         | LUG-01 | BRACKET-14   | 38    |
| <b>ARTIST SERIES, Mongo Santamaria</b>   |           |        |          |          |             |     |     |                  |                |        |              |       |
| MSA11                                    | 11"       | 30"    | •        | •        | •           | •   | •   | TS-B-07          | SSR-08         | LUG-02 | BRACKET-16   | 39    |
| MSA1134                                  | 11 3/4"   | 30"    | •        | •        | •           | •   | •   | TS-B-11          | SSR-10         | LUG-02 | BRACKET-16   | 39    |
| MSA1212                                  | 12 1/2"   | 30"    | •        | •        | •           | •   | •   | TS-B-17          | SSR-13         | LUG-02 | BRACKET-16   | 39    |
| <b>FLOATUNE SERIES</b>                   |           |        |          |          |             |     |     |                  |                |        |              |       |
| FL10                                     | 10"       | 30"    | •        | •        | •           | •   | •   | TS-B-01          | SSR-06         | LUG-01 |              | 40    |
| FL11                                     | 11"       | 30"    | •        | •        | •           | •   | •   | TS-B-03          | SSR-07         | LUG-01 |              | 40    |
| FL12                                     | 12"       | 30"    | •        | •        | •           | •   | •   | TS-B-15          | SSR-12         | LUG-01 |              | 40    |
| FL13                                     | 13"       | 30"    | •        | •        | •           | •   | •   | TS-B-21          | SSR-15         | LUG-01 |              | 40    |
| <b>FIBERCRAFT SERIES</b>                 |           |        |          |          |             |     |     |                  |                |        |              |       |
| FC11                                     | 11"       | 30"    | •        | •        | •           | •   | •   | TS-B-34          | SSR-22         | LUG-01 | BRACKET-14   | 41-43 |
| FC1134                                   | 11 3/4"   | 30"    | •        | •        | •           | •   | •   | TS-B-35          | SSR-23         | LUG-01 | BRACKET-14   | 41-43 |
| FC1212                                   | 12 1/2"   | 30"    | •        | •        | •           | •   | •   | TS-B-36          | SSR-24         | LUG-01 | BRACKET-14   | 41-43 |
| <b>PROFESSIONAL SERIES</b>               |           |        |          |          |             |     |     |                  |                |        |              |       |
| MP11                                     | 11"       | 30"    | •        | •        | •           | •   | •   | TS-B-34          | SSR-22         | LUG-01 | BRACKET-14   | 44/45 |
| MP1134                                   | 11 3/4"   | 30"    | •        | •        | •           | •   | •   | TS-B-35          | SSR-23         | LUG-01 | BRACKET-14   | 44/45 |
| MP1212                                   | 12 1/2"   | 30"    | •        | •        | •           | •   | •   | TS-B-36          | SSR-24         | LUG-01 | BRACKET-14   | 44/45 |
| <b>ARTIST SERIES, Luis Conte</b>         |           |        |          |          |             |     |     |                  |                |        |              |       |
| LC11                                     | 11"       | 30"    | •        | •        | •           | •   | •   | TS-B-52          | TTR-28         | LUG-03 | BRACKET-20   | 47    |
| LC1134                                   | 11 3/4"   | 30"    | •        | •        | •           | •   | •   | TS-B-53          | TTR-29         | LUG-03 | BRACKET-20   | 47    |
| LC1212                                   | 12 1/2"   | 30"    | •        | •        | •           | •   | •   | TS-B-54          | TTR-30         | LUG-03 | BRACKET-20   | 47    |
| <b>MARATHON® CLASSIC SERIES</b>          |           |        |          |          |             |     |     |                  |                |        |              |       |
| MCC11                                    | 11"       | 30"    | •        | •        | •           | •   | •   | TS-B-38          | SSR-25         | LUG-03 | BRACKET-15   | 48-51 |
| MCC1134                                  | 11 3/4"   | 30"    | •        | •        | •           | •   | •   | TS-B-39          | SSR-26         | LUG-03 | BRACKET-15   | 48-51 |
| MCC1212                                  | 12 1/2"   | 30"    | •        | •        | •           | •   | •   | TS-B-40          | SSR-27         | LUG-03 | BRACKET-15   | 48-51 |
| <b>HEADLINER® SERIES WOOD CONGA SETS</b> |           |        |          |          |             |     |     |                  |                |        |              |       |
| HC512 (incl. basket stands)              | 11" + 12" | 28"    | •        |          |             |     |     | HHEAD11/HHEAD12C | HRIM11/HRIM12C | HCLUG  | HCBRACKET-02 | 52/53 |
| HC555 (incl. basket stands)              | 10" + 11" | 28"    | •        |          |             |     |     | HHEAD10/HHEAD11  | HRIM10/HRIM11  | HCLUG  | HCBRACKET-02 | 54/55 |

| SPARE PARTS FOR STANDS                            |          |       |
|---|----------|-------|
| 10" Basket for HC555                              | HSTAND10 | 54/55 |
| 11" Basket for HC555/HC512                        | HSTAND11 | 52-55 |
| 12" Basket for HC512                              | HSTAND12 | 52/53 |
| Rubber Feet (set of 3 pcs.) for Steely-II Stand   | STAND-35 | 56    |
| Rubber Tops (set of 3 pcs.) for Steely-II Stand   | STAND-21 | 56    |
| Screw Set complete for Steely-II Stand, black     | STAND-22 | 56    |
| Screw Set complete for Steely-II Stand, chrome    | STAND-23 | 56    |
| Screw Set complete for Steely-II Stand, gold tone | STAND-24 | 56    |
| Socket Screw (set of 2 pcs.) black                | STAND-26 | 56    |
| Socket Screw (set of 2 pcs.) chrome               | STAND-27 | 56    |
| Socket Screw (set of 2 pcs.) gold tone            | STAND-28 | 56    |

| OTHER PARTS                                  |               |
|--|---------------|
| Lug Oil                                      | SPARE-09      |
| Conga Saver for 8mm Lugs (set of 6 pcs.)     | CONGA-SAVER8  |
| Conga Saver for 10mm Lugs (set of 6 pcs.)    | CONGA-SAVER10 |
| Tuning Key, 13mm + 14mm, L shaped, gold tone | KEY-01        |
| Tuning Key, 13mm + 14mm, L shaped, chrome    | KEY-02        |
| Tuning Key, 14mm, chrome                     | KEY-03        |
| Tuning Key, 13mm, chrome                     | KEY-04        |

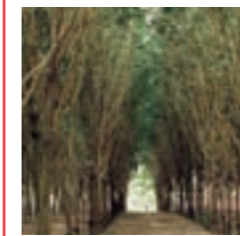

## RUBBER WOOD

(*Hevea brasiliensis* Muell.-Arg.)

The traditional plantation of rubber wood (*Hevea brasiliensis* Muell.-Arg.) in Thailand meets all ecological requirements. In a natural evolution, new trees are planted and the older ones, which have ceased to provide latex, are harvested. In this way, plenty of raw material is available and the valuable rain forest eco-system is preserved. In addition to rubber wood (*Hevea brasiliensis* Muell.-Arg.), we also utilize American White Ash (*Fraxinus americana* L.) which meets all the CITES-regulations set in the "Convention on International Trade in Endangered Species of Wild Fauna and Flora."



## FIBERGLASS

Many percussionists prefer the sound of fiberglass instead of wood, because fiberglass produces a more compact sound with an appealing spectrum of overtones. Premium fiberglass is manufactured by hand laminating layer upon layer which requires extreme patience and dexterity. The result is a truly professional instrument with a unique sound quality.



## TRUE SKIN BUFFALO HEADS

MEINL True Skin Buffalo Heads are without a doubt the perfect choice for both wood and fiberglass congas due to their structure, thickness, and sonic characteristics. True Skin hides are selected by specialists. After the selection process, each skin is gently tanned using a special MEINL procedure and then mounted by hand to become a first class True Skin Head.



## SSR

The MEINL Safe & Sound-Rim (SSR) for congas features a rounded profile to support a comfortable playing feel and prevent palm injuries.



## TTR

The MEINL Traditional-Tuning-Rim (TTR) for congas represents the traditional "Cuban Style." It is closely fitted around the shell and enhances the overall conga sound.



## CONGA SAVER

The patented Conga Saver is truly a MEINL innovation. Available in 8mm and 10mm versions, they are placed over the conga lugs to prevent them from damaging and scratching the shell while the conga remains fully tunable.







## BONGOS

### MIPA AWARD FOR MEINL FREE RIDE SERIES COLLECTION WOOD BONGOS

The "Musikmesse International Press Award" is annually presented by 55 music magazines from all over the world that get together and vote for the best products in certain categories.

The MEINL Free Ride Series Collection Series Bongos won the MIPA Award in the "Best Percussion Product" category.





## FREE RIDE SUSPENSION SYSTEM (patented)

This original MEINL innovation allows, for the first time ever, freely resonating bongo shells.



The Macho and Hembra are no longer attached to each other by a wooden block mounted between the shells, spoiling the resonance of the instrument

With the patented MEINL Free Ride Suspension System the two drums are firmly attached utilizing the bottom rims, which results in not having to drill into the bongo shells

PASSION FOR DETAILS



## FREE RIDE SERIES (patented) COLLECTION WOOD BONGOS

MEINL Collection Series Wood Bongos are the finest bongos available today. They are made entirely by hand and exhibit unparalleled sound, charm, and workmanship. MEINL's expertise in wood selection enables us to study the sonic properties of a large variety of exclusive woods. These extensive studies now reflect in the excellence of our collectors item bongos. The patented MEINL Free Ride System allows freely resonating bongo shells.



**Sizes** 7" Macho & 8 1/2" Hembra  
**Materials** AWA-M = American White Ash (*Fraxinus americana* L.)  
 ROW-M = Rose Wood (*Pterocarpus macrocarpus* Kurz)  
 TW-M = Teak Wood (*Tectona grandis* L.f.)

**Features** MEINL Free Ride Suspension System (patented)  
 Chrome plated hardware  
 True Skin Cow Heads  
 8 mm strong tuning lugs  
 3 mm rounded SSR-Rims  
 Resonance Shaping Area  
**Includes** Accessory pouch  
 L-shaped tuning key  
 Tune Up Oil  
**Finish** Matte

## FREE RIDE SERIES (patented) WOODCRAFT BONGO

The MEINL Woodcraft Bongo, just as the Woodcraft Congas, stands for tradition combined with exceptional workmanship. Only the finest hand selected materials are used to produce this premium bongo which produces the authentic and typical loud slapping bongo sound. The patented MEINL Free Ride System allows freely resonating bongo shells.



**Sizes** 7" Macho & 9" Hembra  
**Material** American White Ash (*Fraxinus americana* L.)  
**Features** MEINL Free Ride Suspension System (patented)  
 Chrome plated hardware  
 True Skin Cow Heads  
 8 mm strong tuning lugs  
 4 mm traditional TTR-Rims  
 Resonance Shaping Area  
**Includes** Accessory pouch  
 L-shaped tuning key  
 Tune Up Oil  
**Colour** ZFA-M = Zebra Finished Ash  
**Finish** Matte

## FREE RIDE SERIES (patented) FWB400 WOOD BONGOS

The MEINL FWB400 Free Ride Series Wood Bongos are the preferred bongo model by many top percussionists. Exceptional sound qualities combined with a wide variety of colours make it the perfect bongo for the working musician. The patented MEINL Free Ride System allows freely resonating bongo shells.



**Sizes** 7" Macho & 8 1/2" Hembra  
**Material** Rubber Wood (*Hevea brasiliensis* Muell.-Arg.)  
**Features** MEINL Free Ride Suspension System (patented)  
 Chrome plated hardware  
 True Skin Cow Heads  
 8 mm strong tuning lugs  
 3 mm rounded SSR-Rims  
 Resonance Shaping Area

**Includes** Accessory pouch  
 L-shaped tuning key  
 Tune Up Oil  
**Colours** ARF = Aztec Red Fade  
 CR = Cherry Red  
 EBK = Ebony Black  
 GAB = Gold Amber Sunburst  
 NT = Natural  
**Finish** Hi Gloss





## 30<sup>TH</sup> ANNIVERSARY EDITION FIBERGLASS BONGO (patented)

The MEINL 30<sup>TH</sup> Anniversary Fiberglass Bongo is a dazzling special edition in a silver-chrome finish. It is highly reflective and looks great under the lights onstage.

**NEW**



- Sizes** 7" Macho & 8 1/2" Hembra
- Material** Premium fiberglass
- Features** MEINL Free Ride Suspension System (patented)  
Chrome plated hardware  
True Skin Cow Heads  
8 mm strong tuning lugs  
3 mm rounded SSR-Rims  
Resonance Shaping Area

- Includes** Accessory pouch  
L-shaped tuning key  
Tune Up Oil
- Colour** CH = Chrome

## FREE RIDE SERIES (patented) FFB400 FIBERGLASS BONGOS

The MEINL FFB400 Free Ride Series Fiberglass Bongos have a stunning sound reaching from powerful mids to sharp highs. Due to their fiberglass shells they are extremely durable and the perfect instrument for the working musician on the road.



- Sizes** 7" Macho & 8 1/2" Hembra
- Material** Premium fiberglass
- Features** MEINL Free Ride Suspension System (patented)  
Chrome plated hardware  
True Skin Cow Heads  
8 mm strong tuning lugs  
3 mm rounded SSR-Rims  
Resonance Shaping Area

- Includes** Accessory pouch  
L-shaped tuning key  
Tune Up Oil
- Colours** BKSP = Black Sparkle  
BSP = Blue Sparkle  
STS = Sterling Silver

## FREE RIDE SERIES (patented) FWB300 WOOD BONGO

The MEINL FWB300 Free Ride Series Wood Bongo is equipped with traditional rims and the finest hand selected cow heads. It produces a warm yet full and voluminous sound. The patented MEINL Free Ride System allows the bongo shells to resonate freely.



- Sizes** 6 3/4" Macho & 8" Hembra
- Material** Rubber Wood (*Hevea brasiliensis* Muell.-Arg.)
- Features** MEINL Free Ride Suspension System (patented)  
Chrome plated hardware  
True Skin Cow Heads  
8 mm strong tuning lugs  
4 mm traditional TTR-Rims

- Includes** Accessory pouch  
L-shaped tuning key  
Tune Up Oil
- Colour** NT-M = Natural
- Finish** Matte

TTR Traditional-Tuning-Rim

Chrome plated 4 mm traditional TTR-Rim

## WB300 WOOD BONGO

Representing the traditional style, the MEINL WB300 Wood Bongo is equipped with a solid woodblock that attaches the two drums together. This enables a sturdy and comfortable way of playing the bongo traditionally between the legs. It features traditional rims and the finest hand selected cow heads, producing a warm, full and voluminous sound.



Interior backing plate adds strength to construction

- Sizes** 6 3/4" Macho & 8" Hembra
- Material** Rubber Wood (*Hevea brasiliensis* Muell.-Arg.)
- Features** Solid woodblock connection  
Chrome plated hardware  
True Skin Cow Heads  
8 mm strong tuning lugs  
4 mm traditional TTR-Rims

- Includes** Accessory pouch  
L-shaped tuning key  
Tune Up Oil
- Colour** SNT-M = Super Natural
- Finish** Matte

## FREE RIDE SERIES (patented) FFB200 FIBERGLASS BONGOS

The MEINL FFB200 Fiberglass Bongos produce a compact sound with a nice spectrum of overtones. They are made from the finest components and are outstanding in quality and workmanship. Ideal for the ambitious beginner who is looking for a semi-professional bongo at an affordable price.



- Sizes** 6 3/4" Macho & 8" Hembra
- Material** Premium fiberglass
- Features** MEINL Free Ride Suspension System (patented)  
Chrome plated hardware  
Hand selected buffalo heads  
8 mm strong tuning lugs  
2.5 mm rounded SSR-Rims

- Includes** Accessory pouch  
L-shaped tuning key  
Tune Up Oil
- Colours** BKSP = Black Sparkle  
BSP = Blue Sparkle  
STS = Sterling Silver



## FREE RIDE SERIES (patented) FWB200 WOOD BONGOS

The MEINL FWB200 Free Ride Series Wood Bongos are made from high quality components and produce a superb tone. The patented MEINL Free Ride System allows the bongo shells to resonate freely.



**Sizes** 6 3/4" Macho & 8" Hembra  
**Material** Rubber Wood  
*(Hevea brasiliensis Muell.-Arg.)*  
**Features** MEINL Free Ride Suspension System (patented)  
 Chrome plated hardware  
 Hand selected buffalo heads  
 8 mm strong tuning lugs  
 2.5 mm rounded SSR-Rims

**Includes** Accessory pouch  
 L-shaped tuning key  
 Tune Up Oil  
**Colours** ARF = Aztec Red Fade  
 GAB = Gold Amber Sunburst  
 NT = Natural  
**Finish** Hi Gloss

## FREE RIDE SERIES (patented) MINI WOOD BONGOS

The MEINL Mini Wood Bongo is a smaller version of a full-sized bongo. It is equipped with professional features in miniature size just like the regular size standard model.



**Sizes** 3 1/2" Macho & 4 1/4" Hembra  
**Material** Rubber Wood  
*(Hevea brasiliensis Muell.-Arg.)*  
**Features** Free Ride Suspension System (patented)  
 True Skin Buffalo Heads  
 Rounded SSR-Rims  
 Chrome plated hardware  
**Includes** Tuning key  
**Colours** SNT-M = Super Natural  
 TSR-M = Tequilla Sunrise  
**Finish** Matte

## PROFESSIONAL BONGO BAG

The MEINL Bongo Bag fits all common bongo models and still has enough room for some hand percussion instruments. A padded separator is included.



**Material** Heavy duty padded nylon  
**Features** Additional room for accessories  
 Padded shoulder strap  
 Carrying grip  
 Padded separator

## 30<sup>TH</sup> ANNIVERSARY EDITION WOOD BONGO (patented)

**NEW**

The MEINL 30<sup>TH</sup> Anniversary Free Ride Wood Bongo comes in our exquisite new Leopard Burl finish. All other features are similar to the FWB190 Wood Bongos.



**Sizes** 6 3/4" Macho & 8" Hembra  
**Material** Rubber Wood  
*(Hevea brasiliensis Muell.-Arg.)*  
**Features** MEINL Free Ride Suspension System (patented)  
 Black powder coated hardware  
 Hand selected buffalo heads  
 8 mm strong tuning lugs  
 2.5 mm rounded SSR-Rims  
**Includes** Accessory pouch  
 L-shaped tuning key  
 Tune Up Oil  
**Colour** LB = Leopard Burl  
**Finish** Hi Gloss

## FREE RIDE SERIES (patented) FWB190 WOOD BONGOS

The MEINL FWB190 Free Ride Series Wood Bongos are perfect for the ambitious beginner and for those who are looking for an affordable second set. Its professional features are outstanding in this price range. The patented MEINL Free Ride System allows freely resonating bongo shells.



**Sizes** 6 3/4" Macho & 8" Hembra  
**Material** Rubber Wood  
*(Hevea brasiliensis Muell.-Arg.)*  
**Features** MEINL Free Ride Suspension System (patented)  
 Black powder coated hardware  
 Hand selected buffalo heads  
 8 mm strong tuning lugs  
 2.5 mm rounded SSR-Rims

**Includes** Accessory pouch  
 L-shaped tuning key  
 Tune Up Oil  
**Colours** CB = Coffee Burst, hi gloss  
 CR-M = Cherry Red, matte  
 SNT-M = Super Natural, matte  
 TSR-M = Tequilla Sunrise, matte





## HEADLINER® SERIES WOOD BONGOS

MEINL Headliner® Series Bongos are perfect for the student or hobbyist who is looking for a high quality instrument right from the beginning.



**Sizes** 6 3/4" Macho & 8" Hembra  
**Material** Rubber Wood  
*(Hevea brasiliensis Muell.-Arg.)*  
**Features** Hand selected buffalo heads  
 8 mm strong tuning lugs  
 2 mm rounded rims  
 Black powder coated hardware  
 Interior backing plates

**Includes** Tuning key  
**Colours** MA = Maple  
 NT = Natural  
 PW = Pearl White  
 VSB = Vintage Sunburst  
 WRB = Wine Red Burst  
**Finish** Hi Gloss

## BONGO BAG

The MEINL standard Bongo Bag offers dependable protection at an affordable price making transportation as hassle free as possible.

**Size** Bongos up to 7 1/2" Macho & 8 1/2" Hembra  
**Material** Heavy duty padded nylon  
**Features** Padded shoulder strap  
 Carrying grip



## PROFESSIONAL BONGO STAND (patented)

The patented MEINL Bongo Stand features a new design concept and simple functionality. The bongo is placed on a padded T-shaped tube and secured with a convenient knob screw. A stable metal clamp holds the entire unit securely in place.

**Material** Chrome plated steel  
**Features** Patented design  
 Padded T-shaped tube  
 Fully height- and angle adjustable  
 Double braced tripod legs  
 Fits all common bongos  
**Includes** Allen wrench  
 Memory locks

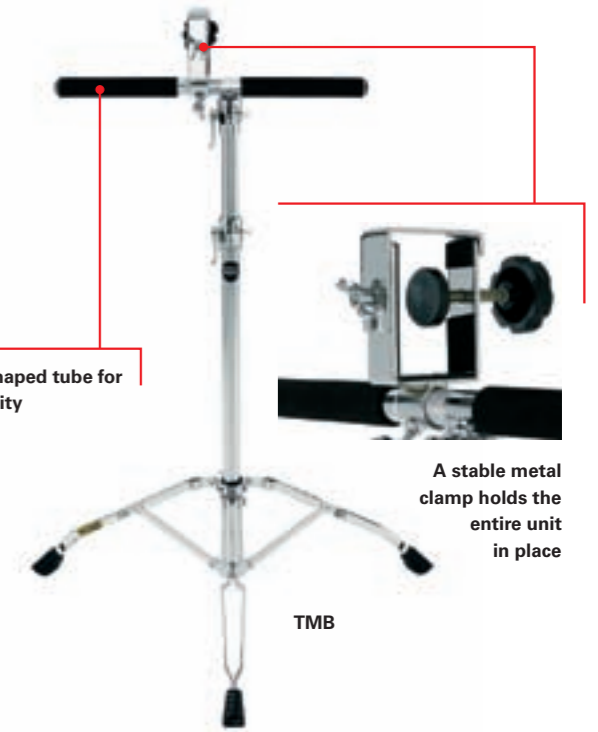

## BONGO STAND (patented)

The MEINL Headliner® Series Bongo Stand (patented) combines easy handling and functionality with reliability and sturdy construction. A newly designed bracket enables extremely quick and easy mounting, yet holds the entire bongo securely in place.



**Material** Chrome plated steel  
**Features** Quick set up  
 Easy handling  
 Reliable placement  
 Double braced tripod stand  
 Fits all common bongos  
**Includes** Wrench



Bertil Mark, Germany  
 (Gentleman & the far  
 east band, M.a.r.s.)

## PROFESSIONAL BONGO STAND (patented) FOR SEATED PLAYERS

This version of MEINL's Professional Bongo Stand (patented) has all the features of its regular model, however it can be placed low enough to be comfortably played sitting down in the traditional position. It is a great stand for drummers who incorporate a bongo into their regular drum set up.

**Material** Chrome plated steel  
**Features** Seated playing position possible  
 Patented design  
 Padded T-shaped tube  
 Fully height- and angle adjustable  
 Double braced tripod legs  
 Fits all common bongos  
**Includes** Allen wrench  
 Memory lock

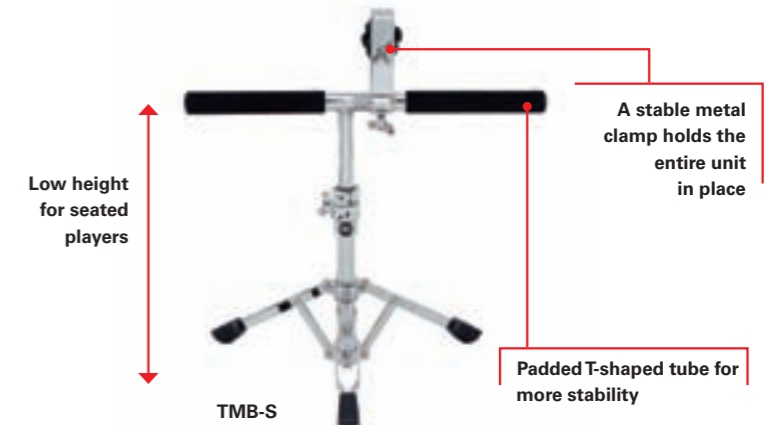



# BONGOS

| Model No.  | Size   | Material   | Features | SPARE PARTS |          |        | Page |
|--|--------|--|----------|-------------|----------|--------|------|
|  |        |  |          | Head        | Rim      | Lug    |      |
|  |        | American White Ash<br>Rose Wood<br>Teak Wood<br>Rubber Wood<br>Premium Fiberglass<br>True Skin Cow Heads<br>SSR-Rim<br>TTR-Rim<br>Free Ride System |          |             |          |        |      |
| <b>FREE RIDE SERIES COLLECTION WOOD BONGOS</b>   |        |  |          |             |          |        |      |
| CS400  | 7"     |  |          | TS-C-02     | SSR-02   | LUG-07 | 64   |
| CS400  | 8 1/2" |  |          | TS-C-03     | SSR-04   | LUG-07 | 64   |
| <b>FREE RIDE SERIES WOODCRAFT BONGO</b>          |        |  |          |             |          |        |      |
| WB500  | 7"     |  |          | TS-C-11     | TTR-26   | LUG-07 | 64   |
| WB500  | 9"     |  |          | TS-C-12     | TTR-27   | LUG-07 | 64   |
| <b>FREE RIDE SERIES FWB400 WOOD BONGOS</b>       |        |  |          |             |          |        |      |
| FWB400   | 7"     |  |          | TS-C-02     | SSR-02   | LUG-07 | 65   |
| FWB400   | 8 1/2" |  |          | TS-C-03     | SSR-04   | LUG-07 | 65   |
| <b>FREE RIDE SERIES FFB400 FIBERGLASS BONGOS</b> |        |  |          |             |          |        |      |
| FFB400   | 7"     |  |          | TS-C-02     | SSR-02   | LUG-07 | 66   |
| FFB400   | 8 1/2" |  |          | TS-C-03     | SSR-04   | LUG-07 | 66   |
| <b>FREE RIDE SERIES FWB300 WOOD BONGO</b>        |        |  |          |             |          |        |      |
| FWB300   | 6 3/4" |  |          | TS-C-13     | TTR-31   | LUG-22 | 67   |
| FWB300   | 8"     |  |          | TS-C-14     | TTR-32   | LUG-22 | 67   |
| <b>WB300 WOOD BONGO</b>                          |        |  |          |             |          |        |      |
| WB300  | 6 3/4" |  |          | TS-C-13     | TTR-31   | LUG-22 | 67   |
| WB300  | 8"     |  |          | TS-C-14     | TTR-32   | LUG-22 | 67   |
| <b>FREE RIDE SERIES FFB200 FIBERGLASS BONGOS</b> |        |  |          |             |          |        |      |
| FFB200   | 6 3/4" |  |          | TS-B-50     | SSR-34   | LUG-23 | 67   |
| FFB200   | 8"     |  |          | TS-B-51     | SSR-35   | LUG-23 | 67   |
| <b>FREE RIDE SERIES FWB200 WOOD BONGOS</b>       |        |  |          |             |          |        |      |
| FWB200   | 6 3/4" |  |          | HEAD-38     | SSR-20   | LUG-22 | 68   |
| FWB200   | 8"     |  |          | HEAD-39     | SSR-21   | LUG-22 | 68   |
| <b>FREE RIDE SERIES MINI WOOD BONGOS</b>         |        |  |          |             |          |        |      |
| FWB100   | 3 1/2" |  |          | TS-B-31     | SSR-16   | LUG-19 | 68   |
| FWB100   | 4 1/4" |  |          | TS-B-32     | SSR-17   | LUG-19 | 68   |
| <b>FREE RIDE SERIES FWB190 WOOD BONGOS</b>       |        |  |          |             |          |        |      |
| FWB190   | 6 3/4" |  |          | HEAD-38     | SSR-18   | LUG-22 | 69   |
| FWB190   | 8"     |  |          | HEAD-39     | SSR-19   | LUG-22 | 69   |
| <b>HEADLINER® SERIES WOOD BONGOS</b>             |        |  |          |             |          |        |      |
| HB100  | 6 3/4" |  |          | HHEAD634W   | HRIM634W | HBLUG  | 70   |
| HB100  | 8"     |  |          | HHEAD8W     | HRIM8W   | HBLUG  | 70   |

| SPARE PARTS FOR STANDS                                      |  |          |
|---|--|----------|
| Memory Clamp, chrome, for middle stand tube for TMB + TMB-S |  | STAND-07 |
| Memory Clamp, chrome, for lower stand tube for TMB + TMB-S  |  | STAND-09 |
| Memory Clamp, chrome, for upper stand tube for TMB          |  | STAND-11 |
| Fast Lock Set, chrome for TMB + TMB-S                       |  | STAND-14 |
| Rubber Feet (set of 3 pcs.) for all Bongo Stands            |  | STAND-16 |
| L-Shaped Clamp for top part for TMB + TMB-S                 |  | STAND-18 |
| Upper Stand Section, complete for TMB                       |  | STAND-34 |

| OTHER PARTS                               |  |          |
|---|--|----------|
| Lug Oil                                   |  | SPARE-09 |
| Tuning Key, 13mm + 14mm, L-shaped, chrome |  | KEY-02   |



## FREE RIDE SUSPENSION SYSTEM (patented)

The Macho and Hembra are no longer attached to each other by a wooden block mounted between the shells, which effects the resonance of the instrument. With the patented MEINL Free Ride Suspension System, the two drums are firmly attached utilizing the bottom rims which results in not having to drill into the bongo shells. It allows, for the first time ever, freely resonating bongo shells.



## RESONANCE SHAPING AREA

The MEINL Resonance Shaping Area is a fine solution to enhance the resonance of the bongos. The center part of the two bongo shells are crafted thinner than usual while still maintaining its full stability. The result is a superior timbre and better resonance of the instrument.



## TRUE SKIN COW HEADS

The original MEINL True Skin Cow Heads are perfect sounding hides for bongos and meet all requirements demanded by professional players. They have outstanding sound qualities, are easy to tune, resilient, and have a smooth surface for comfortable playing. True Skin hides are selected by specialists. After the selection process, each skin is gently tanned using a special MEINL procedure and then mounted by hand to become a first class True Skin Head.



## SSR

The MEINL Safe & Sound-Rim (SSR) for bongos features a rounded profile to support a comfortable playing feel and to assist in the prevention of palm injuries.



## TTR

The MEINL Traditional-Tuning-Rim (TTR) for bongos represents the traditional "Cuban Style." They are narrowly placed around the shell and enhances the overall bongo sound.







## TIMBALES

### MIPA AWARD FOR MEINL ARTIST SERIES LUIS CONTE SIGNATURE TIMBALES

The "Musikmesse International Press Award" is annually presented by 55 music magazines from all over the world that get together and vote for the best products in certain categories.

The MEINL Artist Series Luis Conte Timbales won the MIPA Award in the "Best Percussion Product" category.





## PROFESSIONAL SERIES

*Roland Meinl*

The Roland Meinl Professional Series Timbales are made from finest German B8 cymbal bronze. They produce a fantastic warm sound with cutting rim shots and enhanced Cascara playing.



Made from German B8 cymbal bronze

Applying the logo from underneath the head to prevent from wearing off (patented)

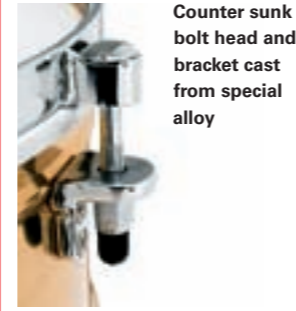

Counter sunk bolt head and bracket cast from special alloy



BT1415



Cuban style flared out bottom edge



Thoughtfully arranged lugs enable an easy way to play the Cascara



**Sizes** 14" & 15"  
**Material** German B8 cymbal bronze  
**Features** Two worked in flanges  
 Cuban style flared out bottom edge  
 Brackets cast from special brass alloy

**Includes** Adjustable cowbell holder  
 Height adjustable tilting double braced tripod stand  
 Accessory pouch  
 L-shaped tuning key  
 Tune Up Oil

## ARTIST SERIES

*Luis Conte*

It is with the greatest appreciation and the deepest respect that we honour our friend Luis and his life's work with his MEINL Artist Series Luis Conte Signature Timbales. Perfection in even the smallest details has been achieved in this outstanding instrument. All of the specifications Luis required for his instrument have been consequently realized.



Luis Conte, USA



Counter sunk bolt head and bracket cast from special alloy



LC1BRASS

LC1STS

Extensively hammered shell

Thoughtfully arranged lugs enable an easy way to play the Cascara



**Sizes** 14" & 15"  
**Material** Solid brass or stainless steel  
**Features** Extensively hammered shells  
 Two worked in flanges  
 Cuban style flared out bottom edge  
 Brackets cast from special brass alloy

**Includes** Adjustable cowbell holder  
 Height adjustable tilting double braced tripod stand  
 Accessory pouch  
 L-shaped tuning key  
 Tune Up Oil

ARTIST SERIES

*Luis Conte*





## ARTIST SERIES

The MEINL Artist Series Amadito Valdès Timbales – a tribute to one of the greatest timbaleros ever.

Amadito Valdès



Amadito Valdès, Cuba



Adjustable cowbell holder

AV1BK



Floatune Tuning System

- Sizes** 14" & 15"
- Material** Black powder coated steel
- Features** Two worked in flanges  
Floatune Tuning System
- Includes** Adjustable cowbell holder  
Height adjustable tilting double braced tripod stand  
Accessory pouch  
L-shaped tuning key  
Tune Up Oil



## FLOATUNE SERIES

The MEINL Floatune Tuning System used on these timbales works without having to drill into the shell. The result is a voluminous timbale sound with a crisp and warm response, cutting rim shots and a great Cascara sound.



Adjustable cowbell holder

T11BK

Floatune Tuning System

- Sizes** 13" & 14"
- Material** Black powder coated steel
- Features** Two worked in flanges  
Floatune Tuning System
- Includes** Adjustable cowbell holder  
Height adjustable tilting double braced tripod stand  
Accessory pouch  
L-shaped tuning key  
Tune Up Oil



## MARATHON® SERIES

MEINL Marathon® Series Timbales are professionally equipped yet are offered at an affordable price. They are perfect for the working percussionist or to be included in a drum setup.

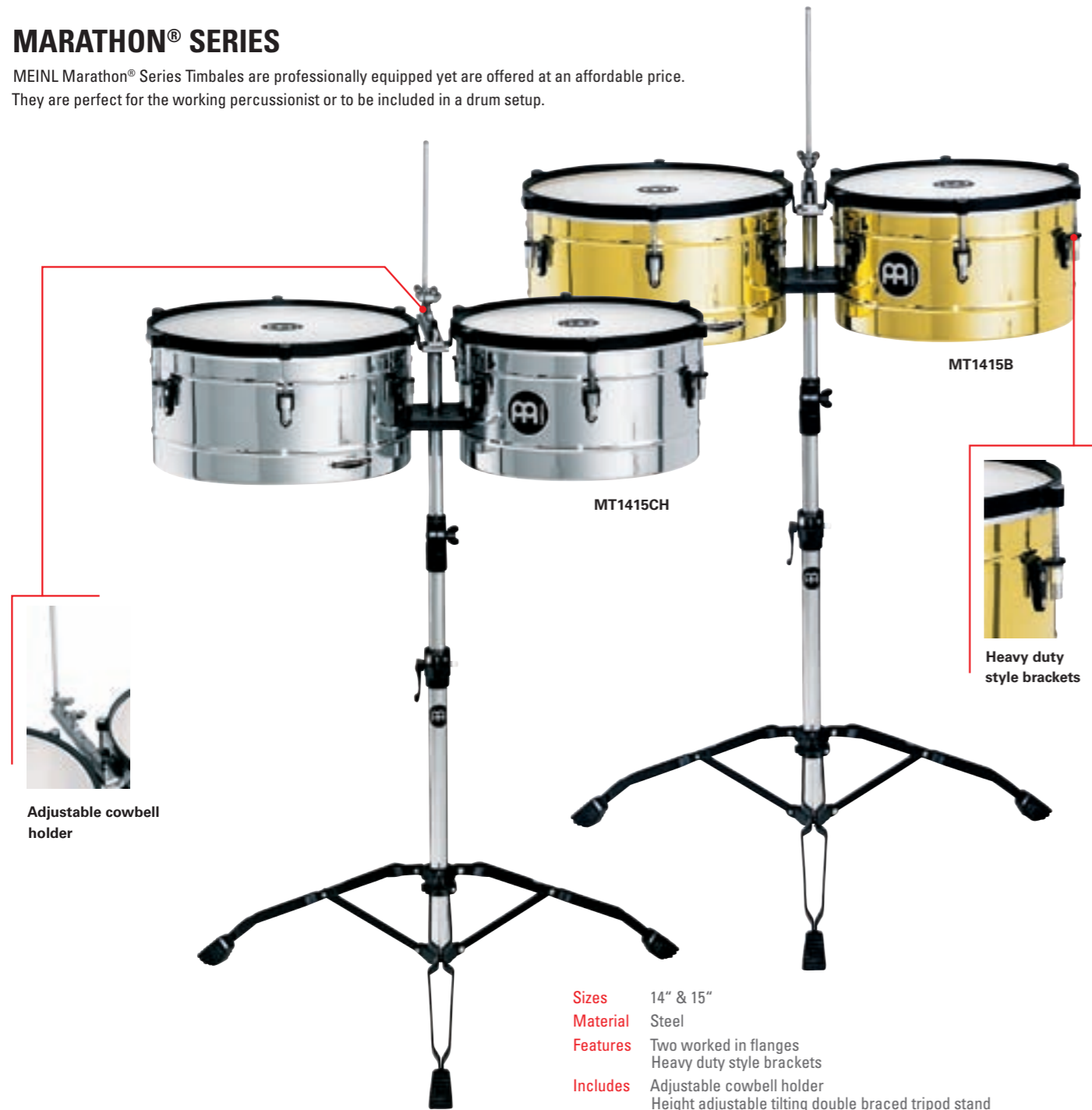

Adjustable cowbell holder

MT1415B

MT1415CH

Heavy duty style brackets

- Sizes** 14" & 15"
- Material** Steel
- Features** Two worked in flanges  
Heavy duty style brackets
- Includes** Adjustable cowbell holder  
Height adjustable tilting double braced tripod stand  
Accessory pouch  
L-shaped tuning key  
Tune Up Oil
- Finishes** Brass  
Chrome

## PROFESSIONAL TIMBALE BAG

The MEINL Timbale Bag has two internal compartments (padded separator included) to fit both timbale drums (up to 15") and an outside pocket to fit the stand, cowbells, and sticks.

- Sizes** 14" & 15"
- Material** Heavy duty padded nylon
- Features** External pocket for stand and cowbell  
Padded shoulder strap  
Carrying grip  
Padded separator



MTB



## HEADLINER® SERIES

The MEINL Headliner® Series Timbales come in 13" and 14" sizes, are made from chrome plated steel and come with a heavy duty-, height adjustable tilting stand. They provide the classic timbale sound and are the perfect introduction to the joy and passion of timbale playing at an affordable price.

## TIMBALE STICKS

The MEINL Timbale Sticks are made out of the finest hand-selected Hickory Wood and are available in four different sizes.



- Sizes** 5/16" x 15", 3/8" x 15", 7/16" x 16 3/4", 1/2" x 16 3/4"
- Material** Hickory Wood



HT1314CH

- Sizes** 13" & 14"
- Material** Steel
- Includes** Height adjustable tilting double braced tripod stand  
Tuning key  
Wrench  
Cowbell holder
- Finish** Chrome

## DRUMMER TIMBALE

### MINI TIMBALE

The MEINL Drummer and Mini Timbale provide the characteristic timbale sounds and project enough to cut through any band setting. It is a perfect addition to any percussion- or drum set configuration.

Original timbale style bracket & tuning lug



MIT810CH

- Sizes** 13" drummer timbale  
8" & 10" mini timbale
- Material** Steel



MDT13CH



Strong mounting clamp attaches to any common L-rod

- Feature** Strong mounting clamp
- Includes** L-shaped tuning key  
Tune Up Oil
- Finish** Chrome



# TIMBALES

| Model No.                            | Size | Material | Features | SPARE PARTS |        |        |                          | Page |
|--------------------------------------|------|----------|----------|-------------|--------|--------|--------------------------|------|
|                                      |      |          |          | Head        | Rim    | Lug    | Bracket                  |      |
| <b>PROFESSIONAL SERIES</b>           |      |          |          |             |        |        |                          |      |
| BT1415                               | 14"  | •        | • • •    | HEAD-22     | RIM-19 | LUG-16 | BRACKET-10 chrome        | 76   |
| BT1415                               | 15"  | •        | • • •    | HEAD-23     | RIM-20 | LUG-16 | BRACKET-11 chrome, small | 76   |
| <b>ARTIST SERIES, Luis Conte</b>     |      |          |          |             |        |        |                          |      |
| LC1                                  | 14"  | • •      | • • • •  | HEAD-22     | RIM-19 | LUG-16 | BRACKET-08 brass         | 77   |
| LC1                                  | 15"  | • •      | • • • •  | HEAD-23     | RIM-20 | LUG-16 | BRACKET-09 brass, small  | 77   |
|                                      |      |          |          |             |        |        | BRACKET-10 chrome        | 77   |
|                                      |      |          |          |             |        |        | BRACKET-11 chrome, small | 77   |
| <b>ARTIST SERIES, Amadito Valdés</b> |      |          |          |             |        |        |                          |      |
| AV1BK                                | 14"  | •        | • • •    | HEAD-22     | RIM-27 | LUG-17 |                          | 79   |
| AV1BK                                | 15"  | •        | • • •    | HEAD-23     | RIM-28 | LUG-17 |                          | 79   |
| <b>FLOATUNE SERIES</b>               |      |          |          |             |        |        |                          |      |
| TI1BK                                | 13"  | •        | • • •    | HEAD-24     | RIM-21 | LUG-17 |                          | 79   |
| TI1BK                                | 14"  | •        | • • •    | HEAD-22     | RIM-22 | LUG-17 |                          | 79   |
| <b>MARATHON® SERIES</b>              |      |          |          |             |        |        |                          |      |
| MT1415                               | 14"  | •        | • • •    | HEAD-22     | RIM-23 | LUG-17 | BRACKET-12               | 80   |
| MT1415                               | 15"  | •        | • • •    | HEAD-23     | RIM-24 | LUG-17 | BRACKET-12               | 80   |
| <b>HEADLINER® SERIES</b>             |      |          |          |             |        |        |                          |      |
| HT1314                               | 13"  | •        | • • •    | HEAD-24     | RIM-37 | LUG-26 | BRACKET-18               | 81   |
| HT1314                               | 14"  | •        | • • •    | HEAD-22     | RIM-38 | LUG-26 | BRACKET-18               | 81   |
| <b>DRUMMER TIMBALE</b>               |      |          |          |             |        |        |                          |      |
| MDT13CH                              | 13"  | •        | • • •    | HEAD-43     | RIM-31 | LUG-21 | BRACKET-13               | 81   |
| <b>MINI TIMBALE</b>                  |      |          |          |             |        |        |                          |      |
| MIT810CH                             | 8"   | •        | • • •    | HEAD-41     | RIM-29 | LUG-21 | BRACKET-13               | 81   |
| MIT810CH                             | 10"  | •        | • • •    | HEAD-42     | RIM-30 | LUG-21 | BRACKET-13               | 81   |

| SPARE PARTS FOR STANDS                         |            |
|--|------------|
| Timbale Stand, chrome                          | TMT        |
| Cowbell Holder, complete for MEINL Timbales    | STAND-01   |
| Cowbell Holder, complete for HT1314 Timbales   | HDSTAND-01 |
| Memory Clamp, chrome for middle stand tube     | STAND-07   |
| Memory Clamp, black for middle stand tube      | STAND-08   |
| Memory Clamp, chrome for lower stand tube      | STAND-09   |
| Memory Clamp, black for lower stand tube       | STAND-10   |
| Fast Lock Set, chrome                          | STAND-14   |
| Fast Lock Set, black                           | STAND-15   |
| Rubber Feet (set of 3 pcs.) for Timbales Stand | STAND-16   |

| OTHER PARTS                                 |          |
|---|----------|
| Lug Oil                                     | SPARE-09 |
| Tuning Key, 13 mm + 14 mm, L shaped, chrome | KEY-02   |



## DIVERSITY IN MATERIALS

MEINL has a great variety of different sounding timbales due to the diversity of materials used in making the shells. Available models include German B8 cymbal bronze, solid brass, stainless steel, black powder coated steel, chrome plated steel, and brass plated steel.



## HAMMERED SHELLS

Extensively hammered shells (Artist Series Luis Conte Timbales) provide the classic dry cascara sound and support the sharpness and projection of the drums.



## FLOATUNE TUNING SYSTEM

The Floatune Tuning System works without having to drill into the shell (Artist Series Amadito Valdés and Floatune Series timbale models). The bottom rim is positioned around the shell before the bottom is flanged. When the head is tensioned the lower rim is drawn upward against the tuning flange and the head and upper rim are drawn downward over the shell.



## FLARED OUT BOTTOM EDGE

The Cuban Style flared out bottom edge increases the projection of the timbale (Artist Series Luis Conte and Professional Series Timbales).



## WORKED IN FLANGES AND CAST BRACKETS

Two flanges are worked into the shell to increase stability. Brackets cast from special brass alloy.



## APPLYING THE LOGO FROM UNDERNEATH THE HEADS (patented)

All MEINL timbale heads are manufactured with the MEINL logo applied onto the head's surface from underneath (patented).

Both drummers and percussionists alike have experienced the same annoying situation with plastic heads: Extensively playing causing the colour of the logo-print to wear out. Not only does it create an unattractive look, but moreover the colour clings to the tip of the drumstick resulting in unwanted black stains that appear on other drumheads, cymbals, or other instruments. This new and original MEINL innovation prevents the colouring of the logo from wearing off and helps to keep your instruments nice and clean.





## SAMBA

The MEINL Samba Series is a line of innovative Brazilian percussion instruments. The variety of different and authentic sounds, innovative features and wide range of accessories combined with light weight materials designed for comfortable playing makes this series invaluable to all percussionists.



## FLOATUNE TAMBORIMS

Tamborims are played with a plastic stick while the other hand changes the pitch of the drum. It has a bright, loud, and cutting sound. MEINL offers a variety of tamborims all made from several high quality materials for several sound options.



Applying the logo from underneath the head to prevent from wearing off (patented)

Light weight ABS guarantees great stability and comfortable handling



Floatune Tuning System

- Size** 6"
- Materials** ABS  
Aluminum  
Brass plated steel  
Chrome plated steel  
Rubber Wood (*Hevea brasiliensis* Muell.-Arg.)
- Features** Floatune Tuning System  
Counter sunk bolt lugs  
Replaceable synthetic heads
- Includes** German "Pfennig" as tuning key

## TAMBORIM STICKS



- Material** Plastic
- Colours** BK = Black  
R = Red

## PROFESSIONAL TAMBORIM BAG

The MEINL Tamborim Bag is made from heavy duty padded nylon with reinforced stitching and is equipped with a double-slide zipper and a shoulder strap. It protects your instruments and provides hassle free carrying.



- Size** 6"
- Material** Heavy duty padded nylon
- Features** Double-slide zipper  
Shoulder strap  
External pocket

Perfect fit

## WOOD PANDEIROS

The Pandeiro is played with one hand while the other alters the pitch of the drum. Solid jingles produce a brilliant, dry and cutting sound.



- Sizes** 10"  
12"
- Material** Rubber Wood (*Hevea brasiliensis* Muell.-Arg.)
- Features** Counter sunk bolt lugs  
Chrome plated hardware  
Replaceable hand selected goat heads
- Includes** Tuning key
- Colour** CN-M = Chest Nut
- Finish** Matte

## PROFESSIONAL PANDEIRO BAGS

The MEINL Pandeiro Bags are made from heavy duty padded nylon with reinforced stitching and are equipped with a double-slide zipper and a shoulder strap. They protect your instruments and provide hassle free transportation.



- Sizes** 10"  
12"
- Material** Heavy duty padded nylon
- Features** Double-slide zipper  
Shoulder strap  
External pocket

## FIBERGLASS QWEEKA

While one hand rubs the internal bamboo shaft with a moist cloth, the other hand controls the pressure of the head, thereby changing the pitch of the tone.



- Size** 8"
- Material** Premium fiberglass
- Features** Floatune Tuning System  
Hand selected goat head
- Includes** Tuning key
- Colour** R = Red



- Sizes** 6"  
10"
- Material** Aluminum
- Features** Counter sunk bolt heads (QW10)  
Hand selected goat heads
- Includes** Tuning key

Internal bamboo shaft





## ALUMINUM CAIXAS

With shells made from premium aluminum, these MEINL Caixas produce the classic bright and cutting sound with penetrating rim shots that these instruments are supposed to deliver. Its light weight yet solid construction makes it perfect for street Samba.

- Sizes** 12" x 4 1/2"  
14" x 4"
- Material** Aluminum
- Features** Replaceable synthetic heads  
Counter sunk bolt heads  
Steel snare wires  
Professional snare throw-off mechanism
- Includes** Tuning key



## PROFESSIONAL CAIXA BAGS

The MEINL Caixa Bags are made from heavy duty padded nylon with reinforced stitching and are equipped with a double-slide zipper, a shoulder strap, and a carrying grip. They protect your instruments and provide hassle free transportation.

- Sizes** 12" x 4 1/2"  
14" x 4"
- Material** Heavy duty padded nylon
- Features** Double-slide zipper  
Extra pocket for spare heads  
Shoulder strap  
Carrying grip  
External pocket



## SAMBA STICKS

MEINL offers a wide assortment of Samba Sticks for Tamborims, Repiniques, and other Samba instruments in order to achieve their authentic sounds. All sticks are made from high quality materials and ensure comfortable playing.

- Material** Plastic
- Sizes** SST1-S = Stick, short version  
SST1-R = Stick, regular version  
SST1-L = Stick, long version  
SST3-S = Triple stick, short version  
SST3 = Triple stick  
SST7 = Sevenfold stick

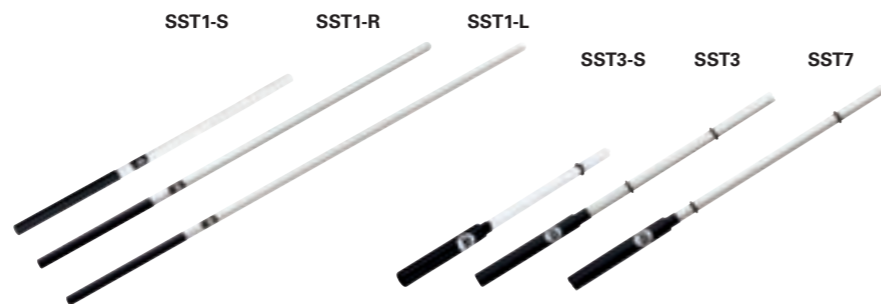

## ALUMINUM REPINIKES

The Repinique is played with a stick while the other hand is used for open tones and slaps. MEINL offers two sizes made from premium aluminum.

- Sizes** 10" x 10"  
12" x 12"
- Material** Aluminum
- Features** Counter sunk bolt heads  
Chrome plated hardware  
Replaceable synthetic heads  
6 tuning lugs (10" model)  
8 tuning lugs (12" model)
- Includes** Tuning key



## WOOD REPINIQUE

For an especially warm and harmonic sound, MEINL offers a Repinique made from wood.



- Size** 12" x 10"
- Material** Rubber Wood  
(*Hevea brasiliensis* Muell.-Arg.)
- Features** Counter sunk bolt heads  
Chrome plated hardware  
Replaceable synthetic heads  
8 tuning lugs
- Includes** Tuning key
- Colour** AB = African Brown
- Finish** Hi Gloss

## PROFESSIONAL REPINIQUE BAGS

The MEINL Repinique Bags are made from heavy duty padded nylon with reinforced stitching and are equipped with a double-slide zipper, a shoulder strap, and a carrying grip. They protect your instruments and provide hassle free transportation.



- Sizes** 10" x 10"  
12" x 12"
- Material** Heavy duty padded nylon
- Features** Double-slide zipper  
Shoulder strap  
Carrying grip  
External pocket

## SAMBA BELT

MEINL offers a high quality belt to ensure a safe and comfortable playing of the Surdo and Repinique. It can be placed around the player's shoulder or hips depending on the required playing position.

- Material** Cotton
- Features** Length adjustable  
Adjustable shoulder padding  
Strong attachment hooks
- Colour** R = Red





## ALUMINUM SURDOS

The deep sound of the Surdo is the heartbeat of Samba music. It is played with a felt beater. MEINL offers several sizes made from premium aluminum.



- Sizes** 16" x 20"  
18" x 22"  
20" x 24"  
22" x 24"
- Material** Aluminum
- Features** Counter sunk bolt heads  
Chrome plated hardware  
Replaceable synthetic heads  
8 tuning lugs (16" & 18" models)  
10 tuning lugs (20" & 22" models)
- Includes** Tuning key

## STAND ALONE ALUMINUM SURDOS

Having a Surdo hanging around the player's shoulders and neck can be exhausting when played that way over a long period of time. MEINL percussion offers stand alone Surdos that are equipped with sturdy, height adjustable legs placed on the floor while playing.



- Sizes** 16" x 20"  
18" x 22"  
20" x 24"  
22" x 24"
- Material** Aluminum
- Features** Height adjustable legs  
Counter sunk bolt heads  
Chrome plated hardware  
Replaceable synthetic heads  
8 tuning lugs (16" & 18" models)  
10 tuning lugs (20" & 22" models)
- Includes** Tuning key

## PROFESSIONAL SURDO BAGS

The MEINL Surdo Bags are made from heavy duty padded nylon with reinforced stitching and are equipped with a double-slide zipper, padded backpack straps, and a carrying grip. They protect your instruments and provide hassle free transportation.



- Sizes** 16" x 20"  
18" x 22"  
20" x 24"  
22" x 24"
- Material** Heavy duty padded nylon
- Features** Double-slide zipper  
Padded backpack straps  
Carrying grip  
External pocket

## SAMBA BEATERS

MEINL offers a wide assortment of Samba Beaters for Surdos and Repiniques in order to achieve their authentic sounds. All beaters are made from high quality materials and ensure a comfortable playing.



- SB1 = 15" long, aluminum stick with 2" felt beater
- SB2 = 16" long, wood stick with 2" felt beater
- SB3 = 16" long, wood stick with 2 1/2" felt beater
- SB4 = 16" long, wood stick with 2" leather beater
- SB5 = 16" long, wood stick with 3" bushy felt beater





## HANDHELD MODELS

The unique feature of the MEINL Handheld Models is a wide and comfortable grip. Ideal for street percussion.

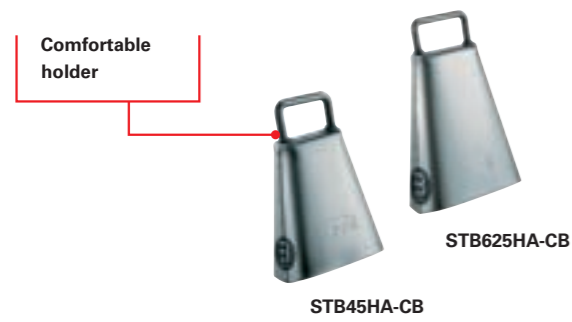

**Sizes** 4 1/2"  
6 1/4"  
**Material** Special steel alloy  
**Feature** Comfortable holder  
**Finish** Hand brushed steel

## HANDHELD MODELS, ALUMINUM

Another true MEINL innovation! They are the perfect handheld bells for Samba music due to their light weight and comfortable grip which keeps the player from tiring, allowing for energetic playing. Aluminum also enables a more soft and musical tone.



**Sizes** 4 1/2"  
6 1/4"  
**Material** Aluminum  
**Features** Light weight construction  
Comfortable rectangular grip

## ALUMINUM SAMBA SHAKERS

The MEINL Samba Shakers are the ideal instruments for street Samba due to their voluminous sound and their ability to cut through loud musical environments. Their shells are made from thin aluminum which, when combined with solid steel shot, produce a warm, penetrating, and cutting shaker sound.

### SINGLE SHAKERS



SSH1-S

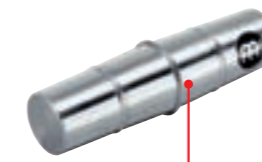

SSH1-M



SSH1-L

**Sizes** Small  
Medium  
Large  
**Material** Aluminum

### DOUBLE SHAKERS



SSH2-S



SSH2-M



SSH2-L

**Sizes** Small  
Medium  
Large  
**Material** Aluminum

### TRIPLE SHAKERS



SSH3-S



SSH3-M



SSH3-L

**Sizes** Small  
Medium  
Large  
**Material** Aluminum

## A-GO-GO STEEL FINISH MODELS

These MEINL A-Go-Go Bells are tonally matched especially for the requirements of South American rhythms.



**Sizes** Small  
Large  
**Material** Special steel alloy  
**Includes** Mounting clamp for small model  
**Finish** Hand brushed steel

## A-GO-GO CHROME FINISH MODELS

These highly polished A-Go-Go Bells offer a bright sound and are equipped with a flexible connection. Ideal for Samba style music.

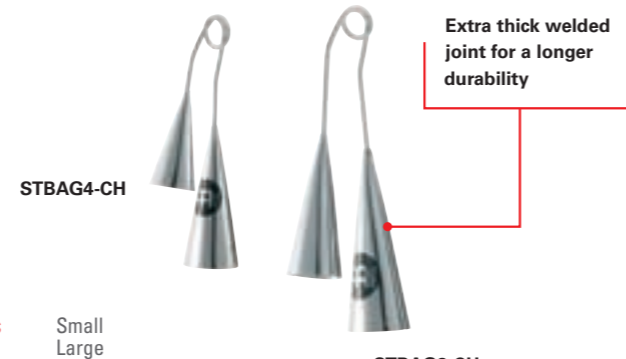

**Sizes** Small  
Large  
**Material** Special steel alloy  
**Feature** Flexible connection  
**Finish** High polished chrome

## ROCAR

The MEINL Rocar is equipped with 20 pairs of solid jingles mounted onto a wooden bar. Due to the Rocar's light weight, it is well suited for parades, festivals and many other occasions.



**Material** Rubber Wood  
(*Hevea brasiliensis* Muell.-Arg.)  
**Colour** BK = Black  
**Feature** 20 pairs of solid jingles

## SAMBA WHISTLE

The MEINL Samba Whistle has three tones in a super-bright timbre. This is the classic Samba sound and spirit. Solid aluminum construction ensures years of use.



**Material** Aluminum  
**Includes** Neck lanyard





# SAMBA

| Model No.                          | Size | Material  | Features  | SPARE PARTS |              |        |            | Page |
|------------------------------------|------|-----------|-----------|-------------|--------------|--------|------------|------|
|                                    |      |           |           | Head        | Rim          | Lug    | Bracket    |      |
| <b>FLOATUNE TAMBORIMS</b>          |      |           |           |             |              |        |            |      |
| TBR06                              | 6"   | • • • • • | • • • • • | HEAD-40     | RIM-32       | LUG-20 |            | 86   |
| <b>WOOD PANDEIROS</b>              |      |           |           |             |              |        |            |      |
| PA10                               | 10"  | • • • • • | • • • • • | HEAD-44     | RIM-33       | LUG-24 | BRACKET-19 | 87   |
| PA12                               | 12"  | • • • • • | • • • • • | HEAD-45     | RIM-34       | LUG-24 | BRACKET-19 | 87   |
| <b>FIBERGLASS QWEEKA</b>           |      |           |           |             |              |        |            |      |
| QW7                                | 8"   | • • • • • | • • • • • | HEAD-13     | RIM-10       | LUG-13 |            | 87   |
| <b>ALUMINUM QWEEKAS</b>            |      |           |           |             |              |        |            |      |
| QW6                                | 6"   | • • • • • | • • • • • | HEAD-57     | RIM-44       | LUG-35 |            | 87   |
| QW10                               | 10"  | • • • • • | • • • • • | HEAD-58     | RIM-45       | LUG-36 |            | 87   |
| <b>ALUMINUM CAIXAS</b>             |      |           |           |             |              |        |            |      |
| CA12                               | 12"  | • • • • • | • • • • • | HEAD-51     | RIM-42 (Top) | LUG-33 |            | 88   |
| CA14                               | 14"  | • • • • • | • • • • • | HEAD-52     | RIM-43 (Top) | LUG-34 |            | 88   |
| <b>ALUMINUM REPINQUES</b>          |      |           |           |             |              |        |            |      |
| RE10                               | 10"  | • • • • • | • • • • • | HEAD-48     | RIM-39 (Top) | LUG-29 |            | 89   |
| RE12                               | 12"  | • • • • • | • • • • • | HEAD-47     | RIM-36 (Top) | LUG-28 |            | 89   |
| <b>WOOD REPINIQUE</b>              |      |           |           |             |              |        |            |      |
| RE12                               | 12"  | • • • • • | • • • • • | HEAD-47     | RIM-36       | LUG-32 |            | 89   |
| <b>ALUMINUM SURDOS</b>             |      |           |           |             |              |        |            |      |
| SU16                               | 16"  | • • • • • | • • • • • | HEAD-59     | RIM-46 (Top) | LUG-37 |            | 90   |
| SU18                               | 18"  | • • • • • | • • • • • | HEAD-49     | RIM-40 (Top) | LUG-30 |            | 90   |
| SU20                               | 20"  | • • • • • | • • • • • | HEAD-46     | RIM-35 (Top) | LUG-27 |            | 90   |
| SU22                               | 22"  | • • • • • | • • • • • | HEAD-50     | RIM-41 (Top) | LUG-31 |            | 90   |
| <b>STAND ALONE ALUMINUM SURDOS</b> |      |           |           |             |              |        |            |      |
| SU16-L                             | 16"  | • • • • • | • • • • • | HEAD-59     | RIM-46 (Top) | LUG-37 |            | 91   |
| SU18-L                             | 18"  | • • • • • | • • • • • | HEAD-49     | RIM-40 (Top) | LUG-30 |            | 91   |
| SU20-L                             | 20"  | • • • • • | • • • • • | HEAD-46     | RIM-35 (Top) | LUG-27 |            | 91   |
| SU22-L                             | 22"  | • • • • • | • • • • • | HEAD-50     | RIM-41 (Top) | LUG-31 |            | 91   |
| <b>OTHER PARTS</b>                 |      |           |           |             |              |        |            |      |
| A Go Go Bell Holder                |      |           |           | STBAGH      |              |        |            |      |
| Tuning Key for Pandeiro            |      |           |           | KEY-08      |              |        |            |      |
| Tuning Key for Caixa               |      |           |           | KEY-09      |              |        |            |      |
| Tuning Key for Surdo and Repinique |      |           |           | KEY-10      |              |        |            |      |



## LIGHT WEIGHT MATERIALS

Samba is mostly played in the streets while marching along to the rhythms of the music. Therefore it is essential that the weight of the instruments is as light as possible, ensuring hours of comfortable and ergonomically sound playing without sacrificing power and projection.

Beginning and professional players alike will appreciate the fact that MEINL percussion is using light weight, yet durable aluminium for crafting our Surdos, Repiniques, Caixas, Qweekas, Handheld Bells and Samba Shakers.



## COUNTER SUNK BOLT HEADS

The attention to detail is what sets MEINL percussion instruments apart. Counter sunk bolt heads on MEINL Qweeka (QW10), all Repiniques and all Surdos allow for energetic playing without having to worry about the bolt heads of the tuning lugs being in the way of the beater. Little details make all the difference in the world.

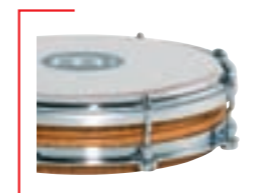

## FLOATUNE TUNING SYSTEM

The MEINL Floatune Tuning System makes drilling holes into the shell unnecessary while enhancing the resonance of the drum and increasing its projection.



## STAND ALONE SURDOS

Having a Surdo hanging around the player's shoulders and neck can be exhausting when played that way over a long period of time. MEINL percussion offers stand alone Surdos that are equipped with sturdy legs placed on the floor while playing.



## APPLYING THE LOGO FROM UNDERNEATH THE HEADS (patented)

All MEINL Samba Instruments equipped with plastic heads are now being made with the MEINL logo applied onto the head's surface from underneath (patented).

This new and original MEINL innovation prevents the colouring of the logo from wearing off and helps to keep your other instruments nice and clean.



## WIDE RANGE OF SAMBA ACCESSORIES

To complete the assortment, a wide range of accessories such as bags, sticks, beaters and a belt are offered for all MEINL Samba Instruments.



# THE FUTURE OF COWBELLS FROM MEINL



THE NEW MULTI-BELL  
— DESIGNED BY RUSS MILLER —

THE ONLY BELL WITH AN ADJUSTABLE TONE

## ARTIST SERIES (patent pending)



The Russ Miller "Multi-Bell" enables multiple tones and is a breakthrough in versatility. You can adjust the amount of ring to your desired level with just a turn of a knob. This innovation brings out the most in a cowbell!

Adjustable interior dampening mechanism

RM80B

- Size** 8" big mouth
- Material** Special steel alloy
- Features** Adjustable interior dampening mechanism  
Hand hammered
- Finish** Hand brushed black

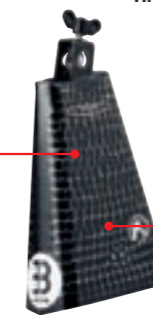

Hand hammered

## HAND HAMMERED MODELS

The strong fundamental tone of these Steelbells make them a unique alternative to all other bells on the market. Each Steelbell has its own character.

STB625HH-G

Hand hammered

STB625HH-C

Extra thick welded joint

STB80BHH-G

STB80BHH-C

**Sizes** 6 1/4"  
8" big mouth

**Material** Special steel alloy

**Feature** Hand hammered

**Finishes** Hand brushed gold  
Hand brushed copper

Russ Miller, USA



Kenny Aronoff, USA



## ARTIST SERIES



Kenny Aronoff says: "My Artist Series Signature Cowbells are the ultimate drummer's bells. Playing live they cut through and have very nice tones. Their recording characteristics are outstanding too."

KA625

Hand hammered

KA80S

- Sizes** 6 1/4"  
8" small mouth
- Material** Special steel alloy
- Feature** Hand hammered
- Finish** High polished chrome

REALPLAYER STEELBELLS

ARTIST SERIES (Russ Miller), HAND HAMMERED MODELS, ARTIST SERIES (Kenny Aronoff)



## REALPLAYER STEELBELLS

MEINL's Realplayer Steelbells are hand made using a special steel alloy. The parts are welded together in a continuous seam and sealed with a protective coating.



**Sizes** 4 1/2" low pitch  
6 1/4"  
8" small mouth  
8" big mouth  
**Material** Special steel alloy  
**Feature** Bright sound  
**Finish** High polished chrome

Special steel alloy for a bright sound

Extra thick welded joint for long durability

## STEEL FINISH MODELS

The pitches of these Steelbells form a diatonic scale which makes it easy to use multiple bell combinations in any musical setting.



**Sizes** 4 1/2" low pitch  
4 1/2" medium pitch  
4 1/2" high pitch  
6 1/4"  
8" small mouth  
8" big mouth  
**Material** Special steel alloy  
**Feature** Tonally matched  
**Finish** Hand brushed steel

Hand brushed steel finish

Easy mountable

Tonally matched

STB80B

STB80S

STB625

STB45H

STB45M

STB45L

## BLACK FINISH MODELS

The MEINL Black Finish Models cowbells have been especially designed to meet all of the requirements of today's modern percussionists and drum set players.



**Sizes** 4 3/4"  
5 1/4"  
8 1/2"  
**Material** Special steel alloy  
**Feature** Muffled sound  
**Finish** Black powder coated steel

Muffled sound

## COWBELL BEATERS

MEINL offers a regular and professional cowbell beater for more sound options.



**Material** Rubber Wood (*Hevea brasiliensis* Muell.-Arg.)  
**Features** Ribbed grip  
Padded beater section

## HANDMATE

The MEINL Handmate is a professional cowbell beater which can be mounted in a setup. This allows hitting the cowbell by hand while playing another instrument.

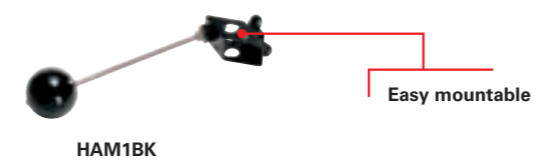

**Material** Steel construction with a wooden ball  
**Feature** Fully adjustable

Easy mountable

## TRIPLE BELL

The three pitch-matched bells combined in one unit, offer the modern percussionist a variety of new playing options. Mounted in a drum set, they can be used in many patterns, techniques and styles. Used in a traditional percussion set up, the MEINL Triple Bell adds new colours and means of expression to the arsenal of sounds.



**Sizes** 2 1/2"  
3 1/2"  
5"  
**Material** Special steel alloy  
**Feature** Muffled sound  
**Finish** Black powder coated steel

Easy mountable

## HAND MODELS

These Bongo Bells easily cut through any high volume performance and are comfortable to hold. They are perfect for a classic bongo pattern.



**Sizes** 6.5"  
7.85"  
8.15"  
**Material** Special steel alloy  
**Finish** Hand brushed steel

## COWBELL BASS DRUM HOLDER

The MEINL Cowbell Holder attaches firmly to the bass drum hoop. Rubber pads prevent scratches on the hoop.

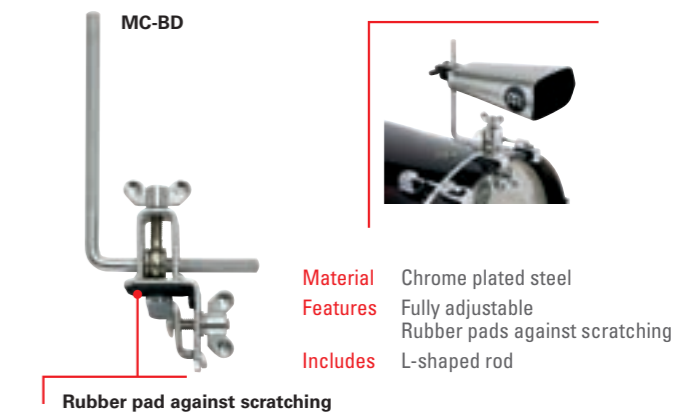

Rubber pad against scratching

**Material** Chrome plated steel  
**Features** Fully adjustable  
Rubber pads against scratching  
**Includes** L-shaped rod



Matthias "Maze" Meusel, Germany (Roger Cicero)



## FRAME DRUMS

The new MEINL Frame Drums join the ancient and glorious tradition of frame drums from all over the world. Frame drums are perhaps as old as civilization itself. Their associated playing techniques have undergone many adaptations and developments over time, with each culture adding its own particular flavor and style. MEINL Percussion is proud to introduce these carefully crafted drums to deliver the fullest potential of this beloved family of instruments. We use the finest hand selected goat skin for the heads and a wooden frame carefully formed for precision and light weight. Our frame drums feature an internal-lug tuning system, ensuring a dependable performance under a variety of conditions.



Javier Villar Morales, Spain

## TAR

**NEW**

The MEINL Tar is a tunable frame drum with a hand selected goatskin head. The tuning lugs are fully recessed within the frame for minimal interference. A scalloped thumb notch and light weight ensures comfortable playing.

- Sizes** 16", 18", 20", 22" and 2 1/2" deep
- Materials** Rubber Wood (*Hevea brasiliensis* Muell.-Arg.)  
Head: Hand selected goat skins
- Feature** Tunable
- Includes** Allen wrench
- Colour** AB = African Brown
- Finish** Matte

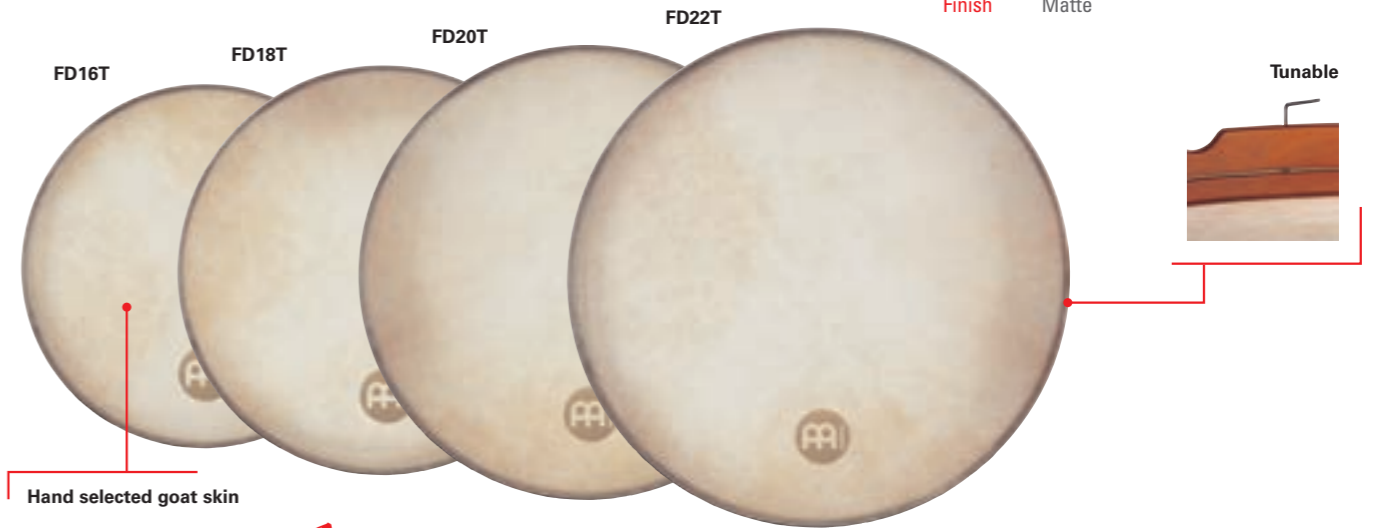

Hand selected goat skin

## BENDIR

**NEW**

The MEINL Bendir features four thin strings stretched across the inside of the goatskin head, which create the classic Bendir "buzzing" sound. The Bendir is fully tunable and light in weight for long and comfortable playing.

- Size** 16" and 2 1/2" deep
- Materials** Rubber Wood (*Hevea brasiliensis* Muell.-Arg.)  
Head: Hand selected goat head
- Feature** Buzzing effect  
Tunable
- Includes** Allen wrench
- Colour** AB = African Brown
- Finish** Matte



Nylon string snare

## PROFESSIONAL FRAME DRUM BAGS

**NEW**

The MEINL Frame Drum Bags are made from heavy duty padded nylon with reinforced stitching. They protect your instruments and provide hassle free transportation.



Double-slide zipper

Heavy duty padded nylon

- Sizes** 16", 18", 20", 22"
- Material** Heavy duty padded nylon
- Features** Double-slide zipper  
Shoulder strap  
Carrying grip



## HAND DRUMS

The MEINL Hand Drums are equipped with the finest hand selected goat heads. The scalloped frame guarantees a comfortable grip, which allows the fingers to apply pressure for a 'bending' note. Their light weight yet solid construction makes them perfect for unplugged situations and street percussion.



**Sizes** 10", 12", 14", 16"  
**Materials** Rubber Wood (*Hevea brasiliensis* Muell.-Arg.)  
 Head: Hand selected goat heads  
**Colour** AB = African Brown

## RECORDING-COMBO TAMBOURINES

The MEINL Recording-Combo Tambourines have a new combination of jingles in two different metals. This creates a whole new sound colour. It is both dry and bright, and it offers a sophisticated and highly adaptable sound, with both projection and sustain.

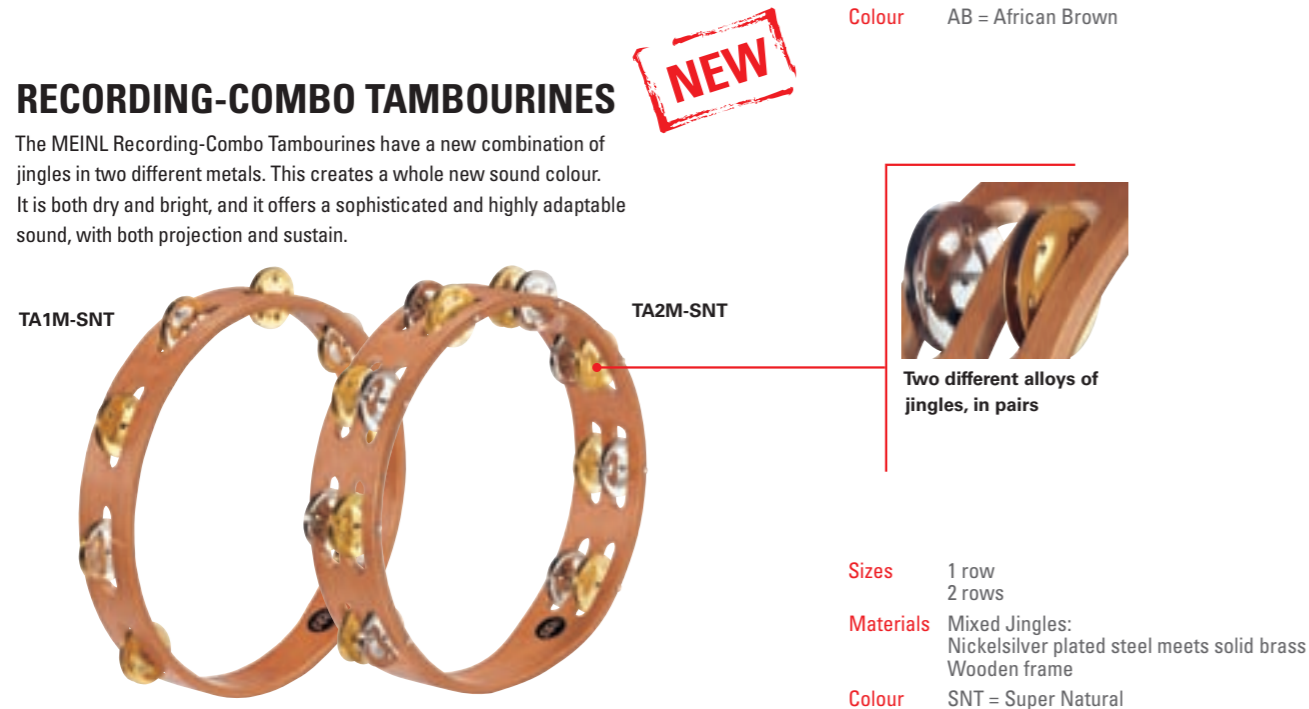

**Sizes** 1 row  
 2 rows  
**Materials** Mixed Jingles:  
 Nickelsilver plated steel meets solid brass  
 Wooden frame  
**Colour** SNT = Super Natural

## HEADED RECORDING-COMBO TAMBOURINES

The MEINL Headed Recording-Combo Tambourines features a hand selected goatskin head for full and warm tones, whether played with stick or hand.



**Sizes** 1 row  
 2 rows  
**Materials** Dual-alloy Jingles:  
 Nickelsilver plated steel meets solid brass  
 Head: Hand selected goat heads  
 Wooden frame  
**Colour** SNT = Super Natural

## WOOD TAMBOURINES, STEEL JINGLES

Featuring 1 or 2 row versions. The MEINL Wood Tambourines with nickel-silver plated steel jingles produce a bright sound that projects well.

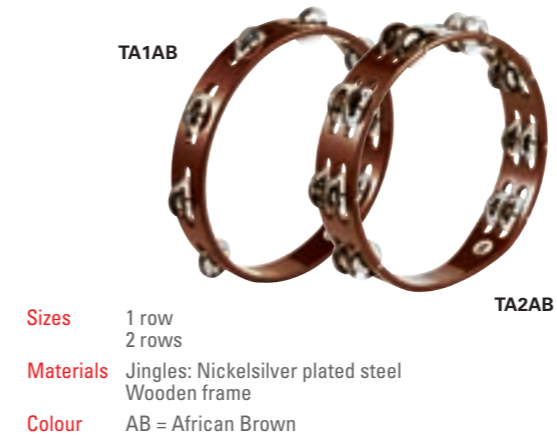

**Sizes** 1 row  
 2 rows  
**Materials** Jingles: Nickelsilver plated steel  
 Wooden frame  
**Colour** AB = African Brown

## HEADED WOOD TAMBOURINES, STEEL JINGLES

With steel jingles and the finest hand selected goat heads firmly attached to the tambourine, this instrument delivers a subtle and gentle tone when played by hand and a voluminous and rich sound.



**Sizes** 1 row  
 2 rows  
**Materials** Jingles: Nickelsilver plated steel  
 Head: Hand selected goat heads  
 Wooden frame  
**Colour** AB = African Brown

## ALUMINUM JINGLES

Featuring 1 or 2 row versions, the MEINL Wood Tambourines with aluminum jingles deliver a very soft and harmonic sound. They are also light weight for extensive and energetic playing.



**Sizes** 1 row  
 2 rows  
**Materials** Jingles: Aluminum  
 Wooden frame  
**Colour** AB = African Brown

## ALUMINUM JINGLES

With aluminum jingles and fine hand selected goat heads firmly attached to the shell, these tambourines have an extra-fine, bright, and sweet sound when played by hand or stick. It is a delicate sound colour that penetrates without over-riding, yet full of power.



**Sizes** 1 row  
 2 rows  
**Materials** Jingles: Aluminum  
 Head: Hand selected goat heads  
 Wooden frame  
**Colour** AB = African Brown

## BRASS JINGLES

Featuring 1 or 2 row versions. Solid brass jingles deliver a distinctively warm, and cutting sound.



**Sizes** 1 row  
 2 rows  
**Materials** Jingles: Solid brass  
 Wooden frame  
**Colour** AB = African Brown

## BRASS JINGLES

With brass jingles and fine hand selected goat heads firmly attached, these tambourines deliver a distinctively warm and cutting sound when played by hand or stick. Featuring 1 or 2 row versions.

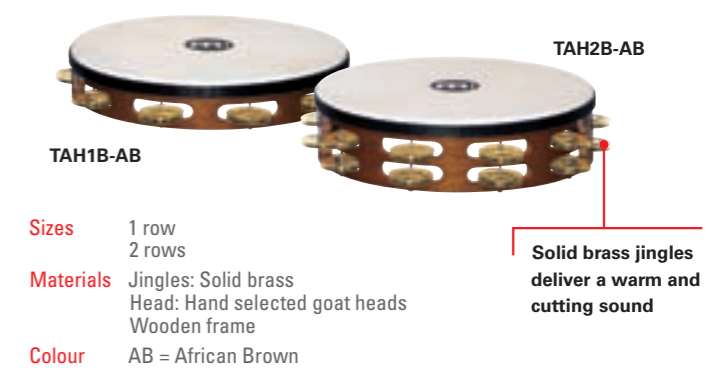

**Sizes** 1 row  
 2 rows  
**Materials** Jingles: Solid brass  
 Head: Hand selected goat heads  
 Wooden frame  
**Colour** AB = African Brown



## ABS TAMBOURINES

MEINL Hand and Set Up Tambourines (design protected by a utility model) have a distinct design advantage due to the construction of the ABS frame. Unlike other tambourines, MEINL utilizes several different parts in the frame which are assembled into a type of "sandwich." This results in unsurpassed durability.

## TAMBOURINES, STEEL JINGLES

These ergonomically shaped tambourines are available as hand held or mountable versions. The durable ABS frame allows hard hitting and energetic hand playing. Nickelsilver plated steel jingles produce a bright sound that projects well.

TMT1BK



A "Guiro" kind of sound can also be produced by scraping the ribbed edge of the frame

TMT1R

Padded ergonomic soft grip for more playing comfort

Easy mountable

TMT2BK



TMT2R

Steel jingles produce a bright sound that projects well

**Materials** Jingles: Nickelsilver plated steel  
Frame: ABS

**Features** Padded soft grip for more playing comfort  
Ergonomic design  
Available as hand held or mountable versions  
Guiro style playing surface  
"Sandwich" construction

**Colours** BK = Black  
R = Red

## TAMBOURINES, ALUMINUM JINGLES

The hand held versions are extremely light weight for extensive and energetic playing. The mountable version is built to resist hard hitting.



TMT1A-WH

TMT1A-B

TMT2A-B

Aluminum jingles produce a very soft and harmonic tone

**Materials** Jingles: Aluminum  
Frame: ABS

**Features** Padded soft grip for more playing comfort  
Ergonomic design  
Available as hand held or mountable versions  
Guiro style playing surface  
"Sandwich" construction

**Colours** B = Blue  
WH = White (hand held only)

## TAMBOURINES, BRASS JINGLES

The durable ABS frame allows hard hitting and energetic hand playing. They deliver a very warm, yet cutting sound.

TMT1B-BK



Solid brass jingles produce a warm, yet cutting sound

TMT2B-BK

**Materials** Jingles: Solid brass  
Frame: ABS

**Features** Padded soft grip for more playing comfort  
Ergonomic design  
Available as hand held or mountable versions  
Guiro style playing surface  
"Sandwich" construction

**Colour** BK = Black

## TAMBOURINE HOLDER

The tambourine holder converts a MEINL Hand Held Tambourine into a set up tambourine. It holds it in place and is made to resist even the hardest hits.

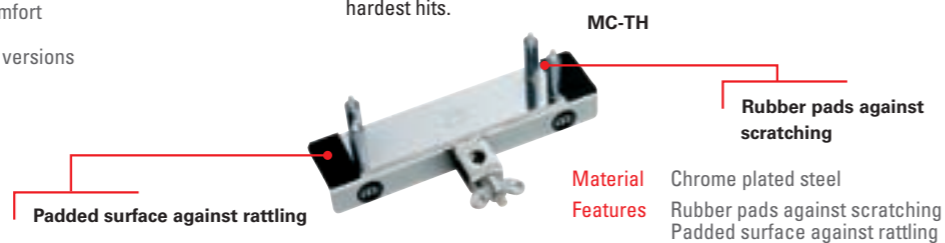

MC-TH

Rubber pads against scratching

**Material** Chrome plated steel

**Features** Rubber pads against scratching  
Padded surface against rattling

Padded surface against rattling

## JINGLE STICKS

The MEINL Jingle Sticks create many interesting sound possibilities.

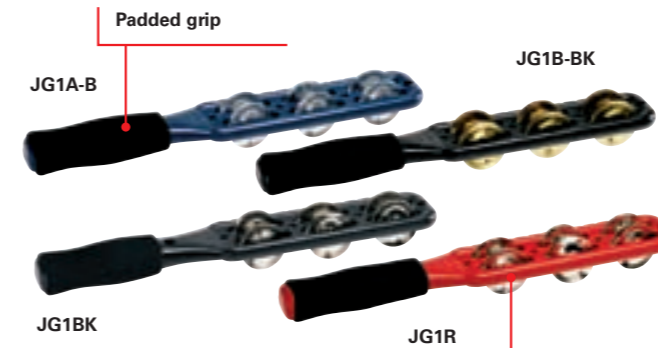

JG1A-B

Padded grip

JG1B-BK

JG1BK

JG1R

**Jingles** JG1 = Nickelsilver plated steel  
JG1A = Aluminum  
JG1B = Solid brass

**Features** Padded grip  
Guiro style playing surface

Guiro style playing surface

## CLAVES DE LUXE

The MEINL Claves De Luxe are made from a superb, dense hardwood which delivers a cutting and bright tone. Due to their small size, they are portable and convenient but still enable a loud, solid rhythmic foundation on stage and in studio sessions.



CL18

Made from superb, dense hardwood

**Size** 6 3/4" long

**Material** Hardwood

**Features** Cutting sound  
Convenient carrying

## WOOD CLAVES, CLASSIC

The MEINL Classic Wood Claves are the most common claves and produce the classic cutting sound. Both the clave and the striker have the same size.



CL1HW

CL1RW

**Materials** HW = Hardwood  
RW = Redwood

**Feature** Solid body

## WOOD CLAVES, AFRICAN

African Claves are slightly larger and have a lower fundamental pitch. Additionally, the resonating body is larger than the striker. Available in two different versions: Solid- and hollowed out body.



CL2HW

CL2RW

CL3HW

CL3RW

**Materials** HW = Hardwood  
RW = Redwood

**Features** CL2 = Solid body  
CL3 = Hollowed out body

## HIHAT TAMBOURINE

NEW

The MEINL Hihat Tambourine is a new effect that fits on any standard hihat rod. It can be set up to compliment hihat cymbals or can be played on its own. Steel jingles provide a bright, cutting sound. A sturdy rubberized striking ring ensures a clean response and a long life. An easy-access wing nut allows quick set-up, adjustment, or removal, all independent from your cymbals.

THH1BK



**Size** 5"

**Material** Steel

**Features** Plated steel jingles  
Rubber padded surface

**Colour** BK = Black



## HEADLINER® SERIES JINGLE STICKS

The MEINL Headliner® Series Jingle Sticks are a nice and affordable alternative to a tambourine. Nice sound effects are also achieved when used as a stick on a drum.



HJS1BK

HJS1R

**Materials** Jingles: Nickelsilver plated steel  
Frame: ABS

**Colours** BK = Black  
R = Red

## FIBERGLASS CLAVES

The MEINL Fiberglass Claves produce the most penetrating, loud, and cutting sound of all. They are hand made from premium fiberglass which makes them nearly indestructible.

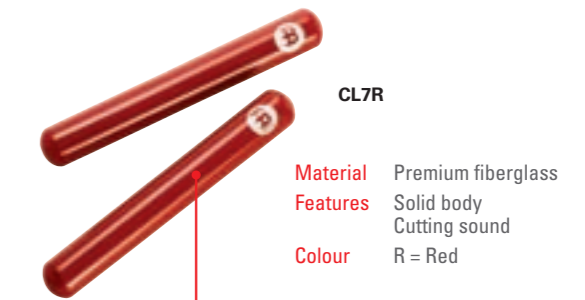

CL7R

**Material** Premium fiberglass

**Features** Solid body  
Cutting sound

**Colour** R = Red

Fiberglass produces the loudest and most cutting sound of all

## TAMBOURINES, JINGLE STICKS, CLAVES

ABS TAMBOURINES, TAMBOURINE HOLDER  
JINGLE STICKS, HIHAT TAMBOURINE, CLAVES



## CHIMES

MEINL Chimes provide great tonal diversity and are available in a wide assortment of sounds. All MEINL Chimes are made from a premium anodized aluminum alloy, and a well balanced wooden bar. A durable nylon cord is used to attach them firmly together.

## ARTIST SERIES

*Luis Conte*

"I wanted a wide spectrum!" comments Luis Conte. "The shorter bars deliver great high pitched sounds. I can get a full and bright chime sound from the medium and low pitched bars. They sound perfect especially in the studio."



## CHIMES, 36 BARS

With bars made from hand polished aluminum, these chimes produce a sound that is clear, bright, and rich in volume and expression.



## ROCK CHIMES, 33 BARS

The bars of MEINL Rock Chimes are thicker for a richer and more voluminous sound.



## CHIMES, 66 BARS

The 66 bar chimes produce a rich and full sound. They cut through any band setting.

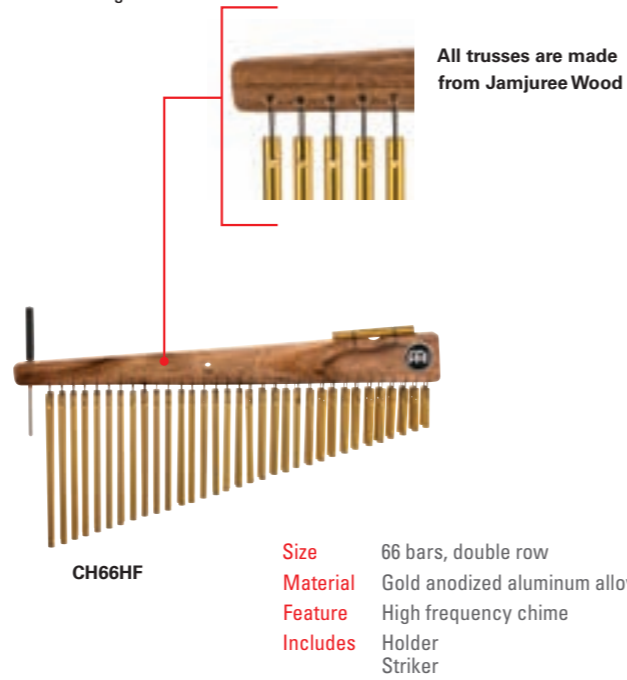

## CHIMES, 33 BARS

The 33 bar chimes produce a very bright sound with a pronounced upper overtone spectrum. They are perfect for all live situations.



## CHIMES, 27 BARS

The 27 bar chimes produce a full sound with a wide tonal spectrum. Ideal for smaller stages and club scenes.



## STUDIO CHIMES, 27 BARS

The Studio Chimes feature slightly thinner bars for a full, rich and tasteful sound.



## CHIMES, 12 BARS

The 12 bar chimes produce a beautiful, high pitched sound. Not too obtrusive, ideal for tasteful chime accents.



## HEADLINER® SERIES CHIMES

The MEINL Headliner® Series Chimes are a great and affordable addition to any percussion set up! They are made from high quality materials and produce a full and warm chime sound.



## CHIMES HOLDERS

These two differently sized MEINL holders comfortably place the chimes within a drum or percussion set up.

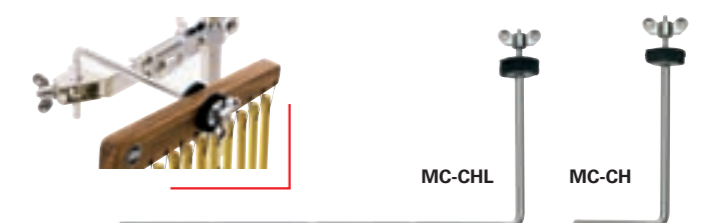

**Sizes** Regular, Large  
**Material** Chrome plated steel  
**Features** Knurled surface, Foam washer

## PROFESSIONAL CHIMES BAG

The MEINL Chimes Bag fits all common chime models and is the perfect solution for transporting these valuable and fragile instruments. Inner velcro straps hold the instrument in place while two internal pockets secure them.

**Material** Heavy duty padded nylon  
**Features** Stores up to 2 chimes, Carrying grip, Inner velcro straps, 2 internal pockets



2 internal pockets with inner velcro straps





## HAND CHIMES

The three differently sized models of these hand chimes are tonally matched. They can easily be played by hand only and still produce a full and rich sound.



- Sizes** 12 bars  
18 bars  
24 bars
- Material** Gold anodized aluminum alloy

## TRIANGLES

The solid brass triangles produce a nice sounding soft tone with a controlled sonic spectrum.



- Sizes** 4"  
6"  
8"
- Material** Solid brass
- Includes** Wooden holder with braided nylon cord  
Metal beater

## HANGING FINGER CYMBALS

Strung on a durable cord and made from a special bronze alloy, 14 unique finger cymbals produce a shimmering chorus effect.

- Size** 2 3/8" diameter
- Material** Special bronze alloy
- Features** Durable cord  
Shimmering sound

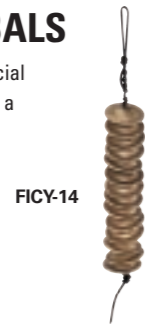

## PROFESSIONAL FINGER CYMBALS

Made from a special bronze alloy and attached with a durable cord, these professional finger cymbals are relatively heavy in weight producing a high pitched and cutting, pure ping sound.

- Size** 2 5/8" diameter
- Material** Special bronze alloy
- Features** Identical, high pitched sound  
Durable cord



## PEG CHIMES

The Peg Chimes are extremely high pitched. They are perfect for special accents.



- Size** 12 pegs
- Material** Gold plated steel

## TRI TONE CHIMES

The three free floating bars create a very long sustain and are tonally matched.

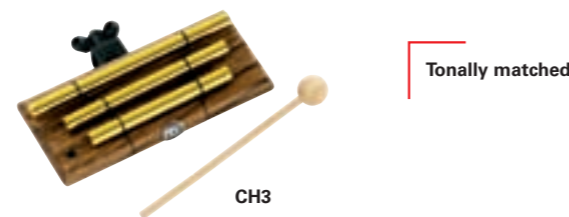

- Material** Gold anodized aluminum alloy
- Feature** Mountable on all common L-rods
- Includes** Wooden beater  
Holder

## TRIANGLE HOLDER

The MEINL Triangle Holder is a simple but effective way to place the triangle in the percussion set up.

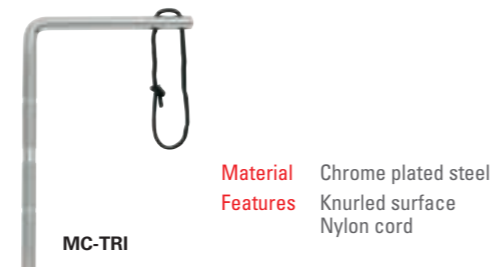

- Material** Chrome plated steel
- Features** Knurled surface  
Nylon cord

## FINGER CYMBALS

Connected with a durable band, these finger cymbals are made from a special bronze alloy, ensuring a clear, delicate and pure sound. Measuring 2 3/8" in diameter, they are easy to hold and comfortable to play.



- Size** 2 3/8" diameter
- Material** Special bronze alloy
- Features** Identical in pitch  
Durable rubber band connection

Special bronze alloy

## TURBO CABASAS (patent pending)

The MEINL Turbo Cabasas are a great innovation, with significantly more volume than normal cabasas. This comes from the sound ports in the resonating chamber. The Turbo Cabasas bring the classic cabasa sound to a new level that will cut through any sonic environment.

- Sizes** Small, regular, large
- Materials** Steel chain and stainless steel cylinder  
Wooden handle with padded soft grip
- Feature** 5 sound ports on each side for more volume
- Colour** BK = Black

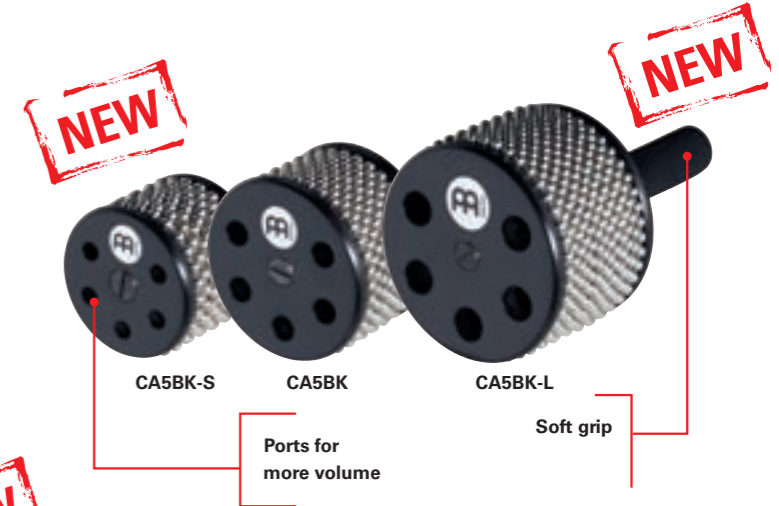

## FOOT CABASA (patent pending)

The MEINL Foot Cabasa is a breakthrough instrument for the percussionist! We mounted a large Turbo Cabasa on our sturdy foot pedal, which adds a new sound to your setup. Keep a cabasa rhythm while your hands play the congas or other drums! The MEINL Foot Cabasa can be set for either a single or double-stroke, according to your taste.

- Size** Large
- Materials** Steel chain and stainless steel cylinder  
Wooden body  
Black powder coated pedal
- Features** Optional single or double-stroke setting
- Includes** Drum key  
Foot pedal

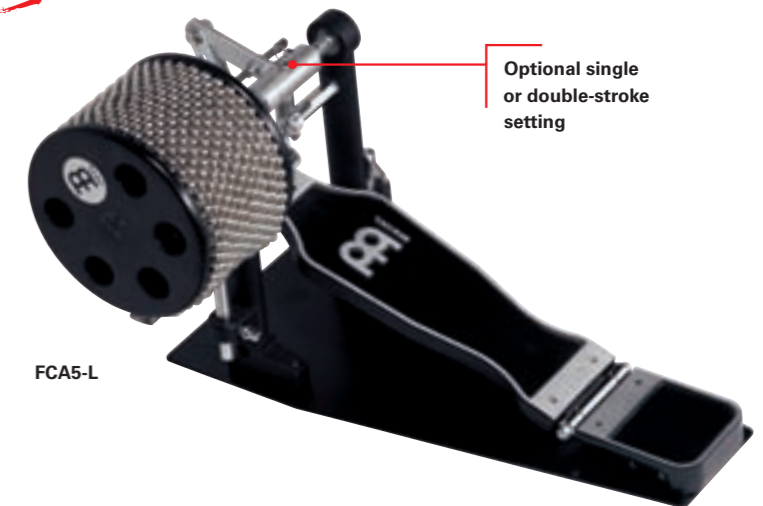

## CABASA HOLDER

This unique attachment holds the cabasa safe and ready to use. The padded surface prevents it from slipping.

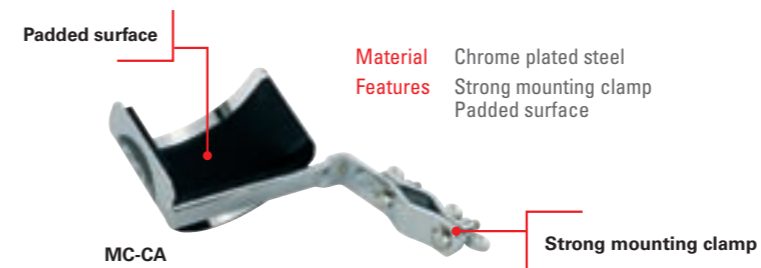

- Material** Chrome plated steel
- Features** Strong mounting clamp  
Padded surface

Strong mounting clamp

## THE NIGHT

When playing The Night, four solid steel balls hit a cylindrical metal rod in quick succession producing the unique sound of crickets.



- Materials** Solid steel balls and cylinder  
Wooden body
- Feature** Ergonomically shaped handle
- Colour** AM = Amber

## KOKIRIKO

The Kokiriko originated in Japan as a sound effect instrument. It produces a rattling effect which can be an almost silent rustling to an extremely loud chatter.

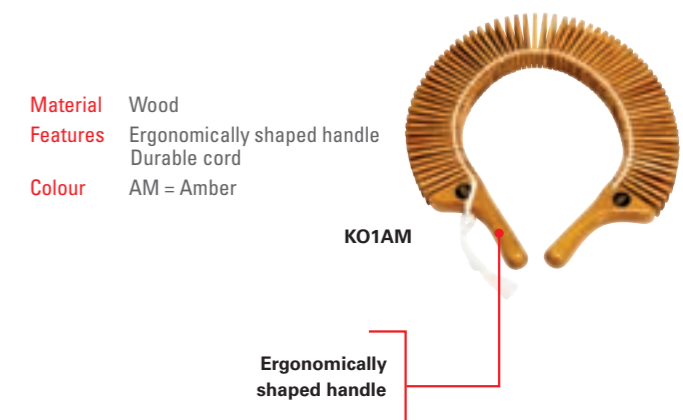

- Material** Wood
- Features** Ergonomically shaped handle  
Durable cord
- Colour** AM = Amber

Ergonomically shaped handle

## THE ROAR

The MEINL Roar is available as a wood and as a fiberglass version. A rattling effect is achieved by striking the ball end against the palm of the hand.

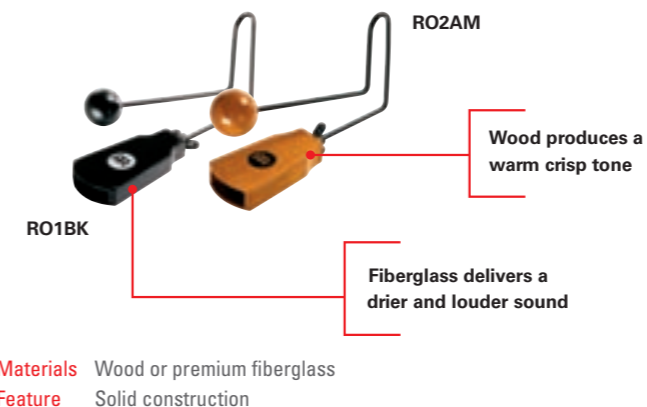

- Materials** Wood or premium fiberglass
- Feature** Solid construction



# THE FUTURE OF SHAKERS FROM MEINL



## SPARK SHAKER

The MEINL Spark Shaker is a very versatile instrument, and is unlike anything heard before. The sparkling, chirping, splashing tones readily mix with almost any musical flavour. The pod-like shape fits easily into the hand and may be manipulated for many interesting effects. Spark Shakers may be played in pairs, or in combination with other shakers for even more variations. It's as unique as the player who knows how to use it.

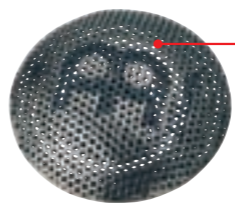

Circular motion enables a unique rattling sound

SH16

**Size** Medium  
**Materials** Shaker: Coated steel  
 Pellets: Coated steel  
**Finish** Black nickel

## SPIN SPARK SHAKER

The MEINL Spin Spark Shaker is equipped with a screw-mounted disc that adjusts and amplifies the characteristics of the fundamental pitch. When the disc is tight, the pitch is highest; and it deepens as the disc is loosened. There is a distinctively pleasant supplemental timbre. The shaker may be manipulated in the hand for many filtering effects.



Screw-mounted disc enables a tunable pitch

SH17

**Size** Medium  
**Materials** Shaker: Coated steel  
 Pellets: Coated steel  
**Finish** Black nickel

## HEADED SPARK SHAKER

One side of the MEINL Headed Spark Shaker is a drum head! Premium goatskin and a steel shell provide a rattling combination of crisp warm tones and a bright metal timbre. Used alone or in combination with the Spark Shaker, its highly variable and "bendable" sound provides a very unique musical character.

**Size** Medium  
**Materials** Shaker: Coated steel  
 Pellets: Coated steel  
 Goat head  
**Finish** Black nickel



Side view

SH18

Sensational effects are produced when combined with another Spark Shaker

## ALUMINUM SHAKERS, OCTAGONAL

MEINL's Octagonal Aluminum Shakers come in two different sizes. Both have a broad dynamic range with lots of volume.



SH8BK



SH88BK

**Sizes** Small  
 Medium

**Material** Aluminum  
**Colour** BK = Black

## ALUMINUM JINGLE SHAKER

The MEINL Aluminum Jingle Shaker (designed by Juan Carlos Melian) has two pairs of steel jingles which are attached in one row to an octagonal aluminum shaker.



JS88BK

By tilting the shaker 90° to the front the jingles start to click on the beat

**Size** Medium  
**Materials** Shaker: Aluminum  
 Jingles: Steel

**Colour** BK = Black



## STUDIO SHAKER

MEINL's Studio Shaker was designed to meet all the requirements necessary in today's session world. It delivers a very tasteful and delicate shaker sound with a warm overall tone and a very well balanced frequency spectrum.



SH10-L-BK

**Size** Large  
**Material** Plastic  
**Colour** BK = Black

## ALUMINUM SHAKERS, ROUND

The MEINL Round Aluminum Shakers were designed to cut through loud live music. Available are two different versions.

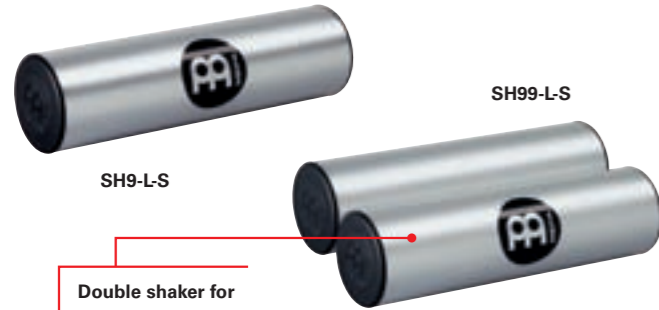

SH9-L-S

SH99-L-S

Double shaker for a louder sound

**Size** Large  
**Material** Anodized aluminum  
**Features** Available as a single, or double shaker  
**Colour** S = Silver

## WOOD SHAKERS

Made from a combination of selected woods, these new MEINL Wood Shakers offer a nice array of alternative sounds. A slightly softer attack combined with a generally warmer sound.

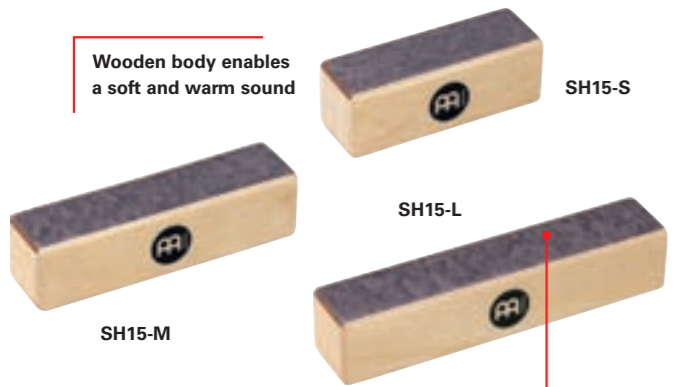

Wooden body enables a soft and warm sound

SH15-S

SH15-L

SH15-M

Black Makah-Burl

**Sizes** Small  
Medium  
Large  
**Materials** Rubber Wood  
(*Hevea brasiliensis* Muell.-Arg.)  
Top and Bottom: Black Makah-Burl

## FIBERGLASS SHAKERS

These MEINL Shakers are made from premium fiberglass for more durability and better sound quality. They are light weight and very comfortable to play.

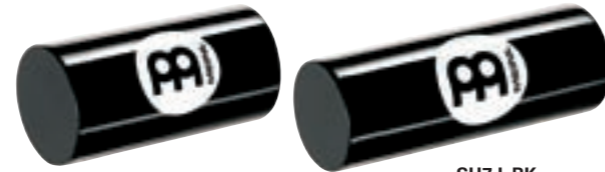

SH7-M-BK

SH7-L-BK

**Sizes** Medium  
Large  
**Material** Premium fiberglass  
**Colour** BK = Black

## SHAKER HOLDER

The MEINL Shaker Holder (designed by Jen Lowe) firmly attaches to any common rod. With its length adjustable specially shaped claws it holds any size shaker in a comfortable position for quick reach.



MC-SH

**Material** Chrome plated steel  
**Features** Rubber pads against scratching  
Length adjustable  
Strong mounting clamp

## SKIN SHAKER

The MEINL Skin Shaker combines two different materials into one unique instrument. It produces very experimental sounds and works perfectly in modern music productions.

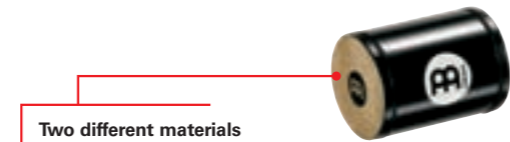

SH6-S-BK

Two different materials produce experimental sounds

**Size** Small  
**Materials** Plastic with natural skin side caps  
**Colour** BK = Black

## U.F.O. SHAKER

The MEINL U.F.O. Shaker produces an extreme mellow and smooth sound and less attack. Therefore it perfectly fits in jazzy and classical arrangements and also ideal for world music.

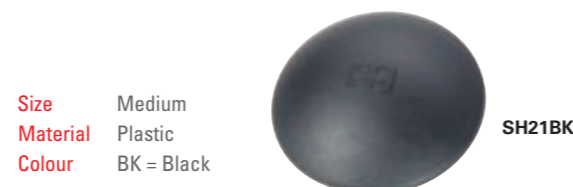

SH21BK

**Size** Medium  
**Material** Plastic  
**Colour** BK = Black

## WAH-WAH SHAKER

The MEINL Wah-Wah Shaker is another unique and innovative instrument, offering yet another voice to a percussionist's range of sounds. The shaker has two chambers which are separated by a plastic membrane. The MEINL Wah-Wah Shaker offers a wide sound spectrum and is a lot of fun to play.

**Size** Medium  
**Materials** Wooden body and plastic chamber  
**Colour** BK = Black



SH20BK

By covering and uncovering the sound hole, a "wah-wah" effect can be achieved

## LOOP SHAKER (patent pending)

The MEINL Loop Shaker has a crackling bright sound with many dynamics, and is easy to control. It is very responsive to hand pressure and movement, giving it a soft or loud voice as needed. The MEINL Loop Shaker has applications in practically any musical setting.

**Size** Medium  
**Material** Plastic  
**Colour** BK = Black

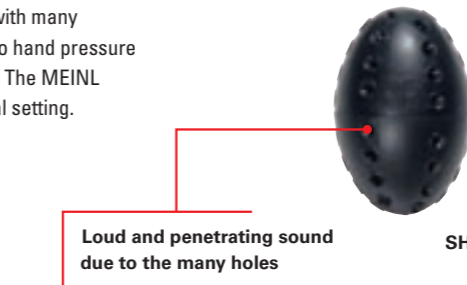

SH3BK

Loud and penetrating sound due to the many holes

## ARTIST SERIES

*Luis Conte*

The three versions have been designed according to master percussionist Luis Conte's exact requirements. "My shaker sound is as smooth as silk" is how Luis described their sound. The new Stadium Shaker has the most volume in the series, with more punch and full precision.

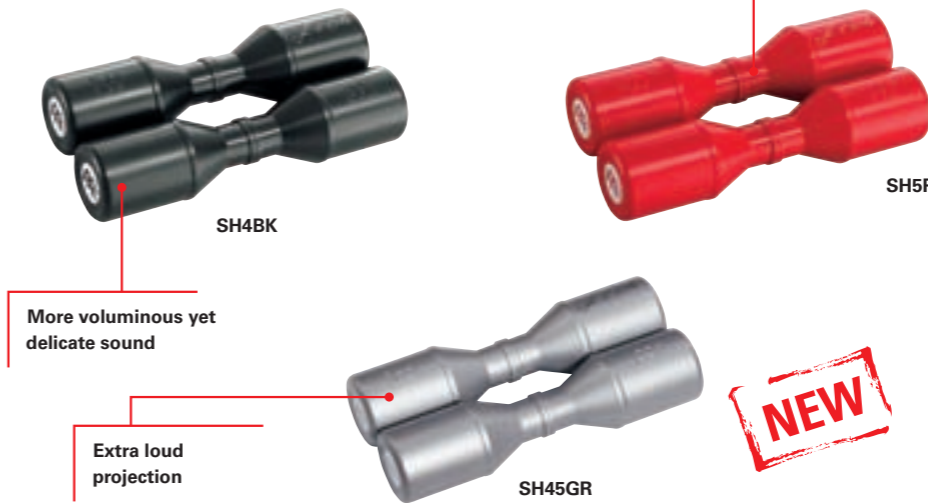

SH4BK

SH5R

SH45GR

More voluminous yet delicate sound

Extra loud projection

**NEW**

**Size** Medium  
**Material** Plastic  
**Feature** Two individual shakers connected as one instrument

**Colours** Live Shaker: BK = Black  
Studio Shaker: R = Red  
Stadium Shaker: GR = Grey



## PERCUSSION BLOCK, HIGH PITCH

The MEINL Percussion Block is made to withstand even the hardest hitting players. It delivers a cutting high pitched sound.



**MPE1BK**

**Material** PE  
**Features** High pitched sound  
 Durability  
**Includes** Mounting Clamp  
**Colour** BK = Black

## WOOD BLOCK HOLDER

A special holder is available to include the MEINL Wood Blocks into any drum- or percussion set up. It can be fixed to any common L-rod.



**MWBH1**

**Material** Chrome plated steel

## FIBERGLASS GUIROS

The MEINL Fiberglass Guiros offer three different striking surfaces for enhanced sounds and padded grip holes.



**GU7BK**

**GU7R**

3 playing surfaces



**Material** Premium fiberglass  
**Features** Three striking surfaces  
 Padded grip holes  
**Includes** Plastic scraper  
**Colours** BK = Black  
 R = Red

## PLASTIC GUIRO

The MEINL Plastic Guiro is precision molded from high strength plastic. It features three different striking surfaces and rubber ringed grip holes for maximum comfort and control.



**GU6BK**

**Material** High strength plastic  
**Features** Three striking surfaces  
 Rubber ringed grip holes  
**Includes** Plastic Scraper  
**Colour** BK = Black

## PERCUSSION BLOCK, LOW PITCH

This MEINL Percussion Block delivers a low pitched sound and is easily mounted on any conventional L-rod.



**MPE2R**

**Easy mountable**

**Material** PE  
**Features** Low pitched sound  
 Durability  
**Includes** Mounting Clamp  
**Colour** R = Red

## WOOD BLOCKS

The two versions of the MEINL Wood Blocks are tonally matched, highly durable and produce a voluminous sound with wood accents.



**MWB1BK**

**MWB2BK**

**Sizes** Small, large  
**Material** Rubber Wood  
 (*Hevea brasiliensis* Muell.-Arg.)  
**Feature** Rounded playing surface  
**Includes** Wooden beater  
**Colour** BK = Black  
**Finish** Matte

## WOOD GUIROS

The traditional MEINL Wood Guiros are available in two different versions and produce a warm and cutting sound.



**GU2AB-M**

**Material** Wood  
**Features** Three striking surfaces  
 Grip holes  
**Includes** Plastic scraper  
**Colour** AB-M = African Brown  
**Finish** Matte



**GU1AM**

**Material** Wood  
**Feature** Grip holes  
**Includes** Wooden scraper  
**Colour** AM = Amber

## GUIRO HOLDER

The MEINL Guiro Holder firmly attaches to any common rod and holds the guiro securely in place while it is played.

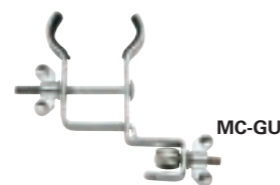

**MC-GU**

**Material** Chrome plated steel  
**Feature** Rubber pads against scratching

## SKIN MARACAS

The MEINL Skin Maracas are entirely made by hand and are offered in three different sizes for a wide sonic range. The two larger models sound especially full and dry, whereas the smaller sized version produces a very tight and high pitched sound.

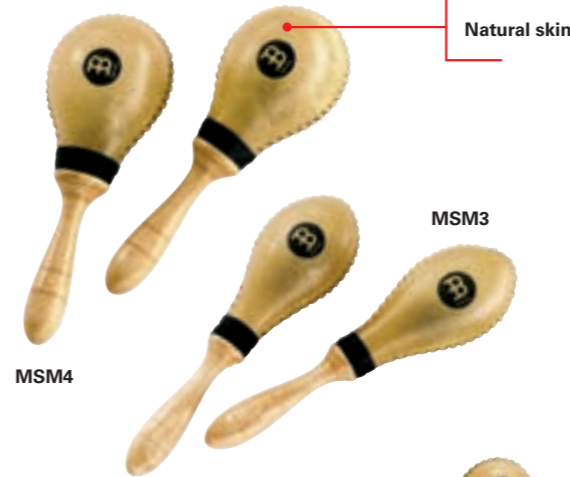

**MSM4**

**MSM3**

**MSM2**

**Sizes** Midi  
 Traditional  
 Jumbo

**Materials** Natural skin  
 Wooden handle

## PLASTIC EGG SHAKERS

The MEINL Plastic Egg Shakers are preferred due to their smooth and crystal clear sound. These have applications in practically any musical setting.

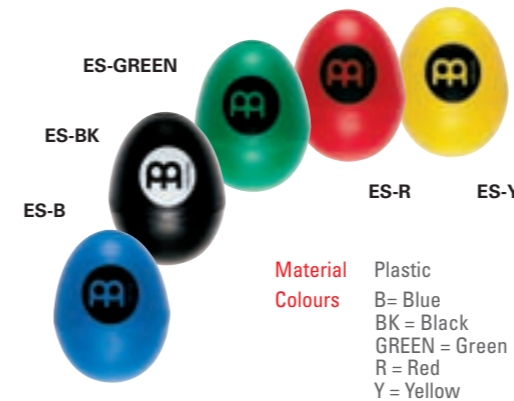

**ES-GREEN**

**ES-BK**

**ES-B**

**ES-R**

**ES-Y**

**Material** Plastic  
**Colours** B = Blue  
 BK = Black  
 GREEN = Green  
 R = Red  
 Y = Yellow

## DOUBLE SHAKER

The MEINL Double Shaker is woven by hand. It offers two different sounds in one instrument.

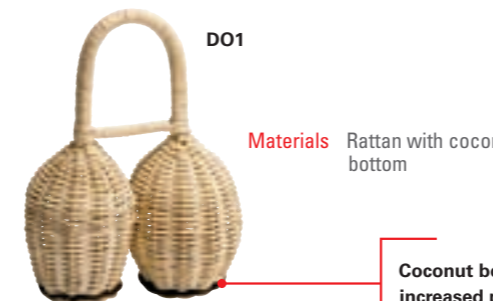

**DO1**

**Materials** Rattan with coconut bottom

**Coconut bottom for increased projection**

## PLASTIC MARACAS

The MEINL Plastic Maracas produce a loud and crisp sound. They are very durable and comfortable to play.



**Materials** Plastic  
 Wooden handle

**PM2BK**

## WOOD MARACAS

The traditional MEINL Wood Maracas are available in both round and oval models. Both of these exhibit a traditional warm and rich sound.



**MWM1MC**

**MWM2AM**

**Material** Wood

## WOOD EGG SHAKER

The MEINL Wood Egg Shaker is turned from wood and deliver a soft yet rich sound. It's perfect in situations which require clearly defined accents.



**ESW-J-BK**

**Size** Jumbo  
**Material** Wood  
**Colour** BK = Black

## CAXIXIS/GANZA

The MEINL Caxixis/Ganza are woven by hand with a coconut bottom. Their sound is crystal clear, high pitched with a great projection.



**CAX1**

**CAX2**

**CAX3**

**GA2**

**Materials** Rattan with coconut bottom



## RITUAL DRUMS

MEINL combines traditional instruments with modern technology and innovations. The range of Ritual Drums is a line of innovative instruments which originate many different cultures from all around the world. MEINL's expertise in R&D helped in creating these authentic and high quality instruments which are outstanding in the percussion world.



Bill Summers, USA

## CABASA, FIBERGLASS

The shape and function of the MEINL Fiberglass Cabasa equals a traditional gourd calabash. The MEINL fiberglass version however offers positive stability and dynamic sound quality.

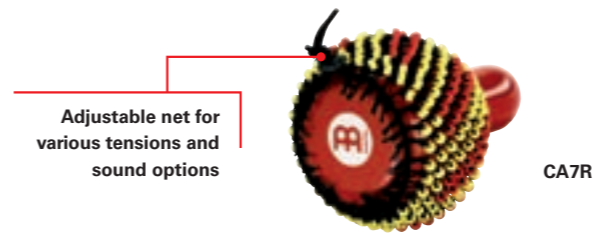

Adjustable net for various tensions and sound options

CA7R

**Material** Premium fiberglass  
**Colour** R = Red

## SHEKERE, JUMBO SIZE

MEINL's Jumbo Size Shekere is hand made from premium fiberglass and fitted with a net of beads.

Wide sound spectrum from low bass tones to loud, high pitch rattle sound

SH2VSB

**Material** Premium fiberglass  
**Colour** VSB = Vintage Sunburst

## BIRDS/WATERFALL

The MEINL Birds and Waterfall realistically imitate the sound of a flock of birds or a rippling waterfall. By using fiberglass a bright sound is produced, the dynamic range is increased and an optimum durability is realized.

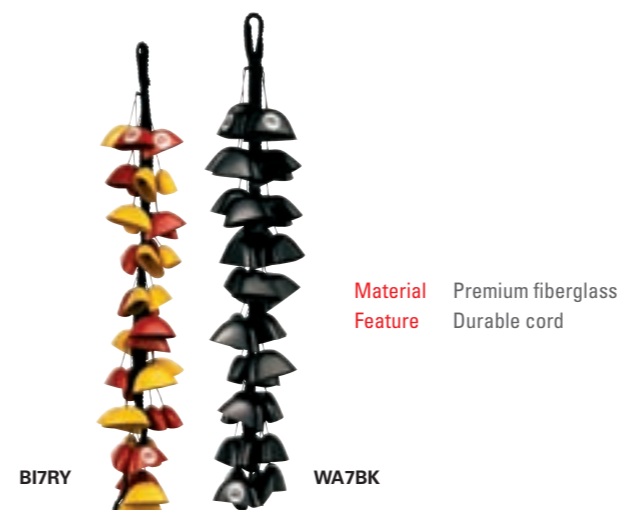

BI7RY

WA7BK

**Material** Premium fiberglass  
**Feature** Durable cord

## TALKING DRUM

The Talking Drum has its origin in West Africa. The traditional technique involves squeezing the tuning ropes while striking the head with a thin bent wooden mallet.

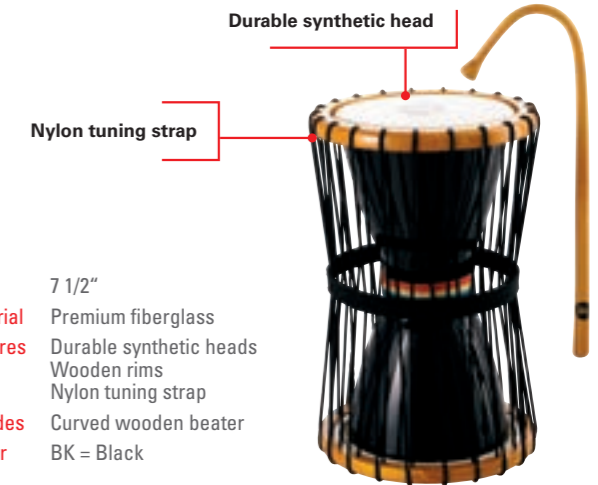

Durable synthetic head

Nylon tuning strap

TD7BK

**Size** 7 1/2"  
**Material** Premium fiberglass  
**Features** Durable synthetic heads  
Wooden rims  
Nylon tuning strap  
**Includes** Curved wooden beater  
**Colour** BK = Black

## SHEKERE

The MEINL Shekere is handmade from premium fiberglass and fitted with a net of beads. It delivers a crisp sound and unlike gourd shekeres it is nearly unbreakable.

SH1BK

**Material** Premium fiberglass  
**Colour** BK = Black

## BIRDS/WATERFALL

The MEINL Birds and Waterfall made out of Rubber Wood (*Hevea brasiliensis* Muell.-Arg.) enable a brighter timbre and a more penetrating sound.



BI1NT

WA1NT

**Material** Rubber Wood (*Hevea brasiliensis* Muell.-Arg.)  
**Feature** Durable cord  
**Colour** NT = Natural



## HELIX BOWL, BILL SARAGOSA LINE

The MEINL Helix Bowl is a wonderful new instrument consisting of a steel helix welded to a resonating chamber. The Helix Bowl is either stroke or struck, and is played off the body in the manner of a berimbau, for a deep resonating wah-wah effect. Optional dampening is possible with just a touch of a finger.



**Material** Special steel alloy  
**Includes** Metal beater  
**Finish** Black nickel

BOWL

### Bill's Quote:

"This is one of the most unusual sounding and streamlined instruments I have cooked up! The resonance is really deep and spacey, yet so easy to control. The helix is designed to be accessible in almost any direction, so you can develop lots of different stroke textures. The manipulation of the resonator bowl against your belly can give you a mysterious "Shamanic" sound, like a berimbau or wah-wah tube. It's kind of a jungle sound from outer space."

## WAH-WAH TUBES

The MEINL Wah-Wah Tube is a tubular effect instrument that delivers smooth, bell-like tones with an incredible sustain.



**Sizes** Small (high pitch)  
 Large (low pitch)  
**Material** Aluminum  
**Includes** Rubber mallet  
**Colour** BK = Black

## RAINMAKER

The MEINL Rainmaker is uniquely different. Due to the circular construction, it can be mounted on a cymbal stand and by simply turning the instrument a drizzle can immediately change into the sound of a monsoon.



RA7BK

**Material** Premium fiberglass  
**Feature** Circular construction  
**Includes** Ergonomically shaped handle  
**Colour** BK = Black

## LIQUID TRIANGLE, BILL SARAGOSA LINE

The MEINL Liquid Triangle is a solid steel triangle, welded securely to a steel shell, creating a chamber which contains liquid and is closed with a very thin plate. The triangle portion may be played in the classical manner, while the chamber creates eerie resonant overtones. The general angle of the instrument will affect the specific pitch of the overtones, and this can be modulated by hand movements. The instrument may be struck or bowed on any portion of its surface.



TRIL

Filled with water

**Material** Special steel alloy, filled with water  
**Feature** Wide sound spectrum  
**Includes** Metal beater  
**Finish** Black nickel

### Bill's Quote:

"This instrument is a classic. I've put these through a lot of abuse and a lot of miles, and they hold up just great. Take a moment and get to know the Liquid Triangle... There is a lot going on inside this shape."

## BERIMBAU

The MEINL Berimbau is another traditional African instrument that is a commonly found in the music from Brazil and other South American countries. It is the staple instrument of Capoeira, the famous martial arts dance. The thin striker and a caxixi are held in the right hand, while the left hand supports the bow and modulates the string with a small metal disc. The whole instrument is moved off-and-on the abdomen, opening and closing the resonant gourd, for a captivating "wah-wah" effect.

By covering and uncovering the sound hole a "wah-wah" effect can be achieved

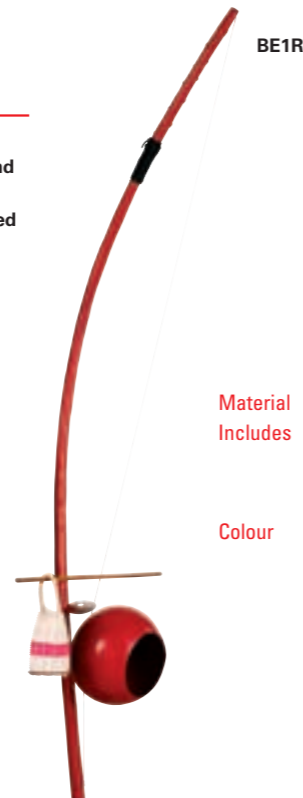

**Material** Premium fiberglass  
**Includes** Small Caxixi  
 Metal plate  
 Wooden stick  
 Carrying bag  
**Colour** R = Red

## RAMWONG

Ramwong is a Thai folk dance which evolved from Ramthone, a popular festive season in a certain region in Thailand. Ram means dance and Thone is a small drum.

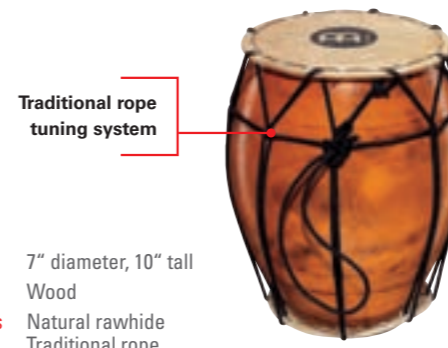

Traditional rope tuning system

RAMWONG7

**Size** 7" diameter, 10" tall  
**Material** Wood  
**Features** Natural rawhide  
 Traditional rope tuning system

## WOOD CONGUITAS

The Conguitas are a perfect addition to any percussion set up. They are made from high quality materials and produce a cutting and strong percussive tone which complements the congas in a harmonically supportive sound spectrum.



HCG89NT

Heavy duty stand can be tilted

**Sizes** 8" & 9"  
**Material** Rubber Wood  
 (Hevea brasiliensis Muell.-Arg.)  
**Features** 8 mm strong tuning lugs  
 Original MEINL style tuning brackets  
 Traditional rims  
 Black powder coated hardware  
 Hand selected buffalo heads

**Includes** Height adjustable tilting  
 double braced tripod stand  
 Tuning key  
 Wrench  
**Colour** NT = Natural  
**Finish** Hi Gloss

## TAMBORA

The rhythm of the Merengue has its roots in the Dominican Republic where the use of a Tambora drum is essential in creating this style of music.



MTA1SNT-M

**Size** 11"  
**Material** Rubber Wood  
 (Hevea brasiliensis Muell.-Arg.)  
**Features** True Skin Buffalo Heads  
 Black powder coated hardware  
**Includes** Nylon strap  
 Wooden beaters  
 Tuning key  
**Colour** SNT-M = Super Natural  
**Finish** Matte

Nylon strap

## BATAS

The MEINL Batas are made from premium fiberglass for more durability, lighter weight and comfortable playing, and have a traditionally authentic sound.



BA1BK

BA3BK

BA2BK

**Sizes** Okonkolo 5 1/4" & 8"  
 Itotele 5 3/4" & 8 3/4"  
 Iya 6 3/4" & 12"  
**Material** Premium fiberglass  
**Features** Hand selected buffalo heads  
 Traditional TTR-Rims  
**Includes** Nylon strap  
 Tuning key  
**Colour** BK = Black



## IBO DRUMS

The MEINL Ibo Drums perfectly combine tradition with modern innovation. "Ibo" is the Nigerian name for "pottery" where these unique drums originate. They all have a wide spectrum of sounds, are easy to play and offer many great features.

### FIBERGLASS IBO DRUM

The MEINL Fiberglass Ibo Drum has a wide variety of different sounds and the fiberglass body makes it nearly unbreakable.



- Size** Large
- Material** Premium fiberglass
- Features** Built in microphone hole  
Resistant shell construction
- Includes** Foam padded base
- Colour** BKR = Black/Red

ID1BKR

### FIBERGLASS IBO DRUM, LONG NECK

The MEINL Fiberglass Ibo Drum has a wide variety of different sounds and the fiberglass body makes it nearly unbreakable.



- Size** Long neck
- Material** Premium fiberglass
- Features** Built in microphone hole  
Resistant shell construction
- Includes** Foam padded base
- Colour** BKR = Black/Red

ID2BKR

### FIBERGLASS TRI SOUND IBO DRUM

The MEINL Tri Sound Ibo Drum features an additional rawhide playing surface and an extra thin bottom for enhanced sound.



- Size** Large
- Material** Premium fiberglass
- Features** Rawhide playing surface  
Built in microphone hole  
Resistant shell construction
- Includes** Foam padded base
- Colour** GO = Gold Ornament

ID3GO

### IBO HOLDER

The MEINL Ibo Holder securely supports most common ibo drums in a comfortable position while enabling you to play the ibo with both hands, or with one hand free for other instruments.



- Material** Black powder coated steel
- Includes** Allen wrench  
Foam padded base

TMIH

### FIBERGLASS TRI SOUND IBO DRUM

The MEINL Tri Sound Ibo Drum features an additional fiberglass playing surface and an extra thin bottom for enhanced sound.



- Size** Large
- Material** Premium fiberglass
- Features** Extra fiberglass playing surface  
Built in microphone hole  
Resistant shell construction
- Includes** Foam padded base
- Colour** BKO = Black Ornament

ID4BKO

### WOOD IBO DRUM

This unique instrument is another true MEINL innovation. It features a wooden body for a wide sonic range.

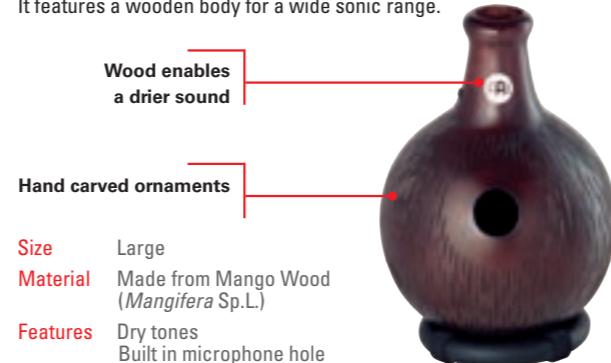

- Wood enables a drier sound**
- Hand carved ornaments**
- Size** Large
- Material** Made from Mango Wood (*Mangifera Sp.L.*)
- Features** Dry tones  
Built in microphone hole
- Includes** Foam padded base

ID6

## CERAMIC IBO DRUM

The ceramic body of this Ibo Drum causes a slight enhancement of the higher frequencies, with fat and powerful bass tones.

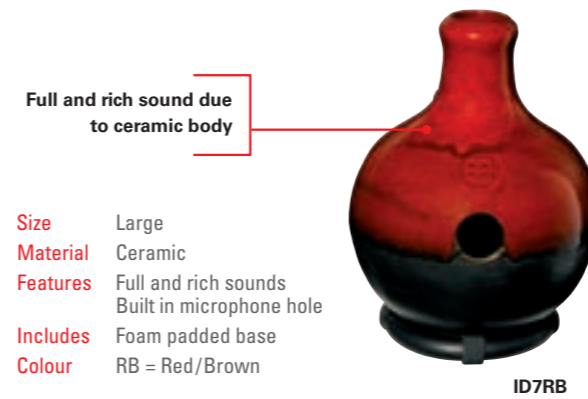

- Full and rich sound due to ceramic body**
- Size** Large
- Material** Ceramic
- Features** Full and rich sounds  
Built in microphone hole
- Includes** Foam padded base
- Colour** RB = Red/Brown

ID7RB

## CERAMIC IBO DRUM

The special feature of this MEINL Ceramic Ibo Drum is the fiberglass bottom for extra sound options.



- Size** Large
- Material** Ceramic
- Features** Fiberglass playing surface  
Built in microphone hole
- Includes** Foam padded base
- Colour** RB = Red/Brown

Extra fiberglass bottom for more sound options

ID8RB

## PROFESSIONAL IBO STAND

The MEINL Ibo Stand was designed to enable playing an Ibo Drum in ways other than simply being placed in one's lap, such as standing up or incorporating it into a percussion set up. It can be angled and is fully height adjustable.



Foam padded ring

- Material** Chrome plated steel
- Features** Foam padded ring  
Fully height- and angle adjustable  
Double braced tripod legs
- Includes** Allen wrench  
Memory lock

TMID

## PROFESSIONAL IBO BAGS

The MEINL Ibo Bag fits all common clay drum models and is the perfect solution for transporting these valuable and fragile instruments. Its heavy duty padded outside walls store it securely and prevents damage.



MIB-M

MIB-S

- Sizes** Small (9 3/4" W x 13 1/3" H x 9 3/4" D)  
Medium (11" W x 14 1/2" H x 11" D)
- Material** Heavy duty padded nylon
- Includes** Padded shoulder strap  
Carrying grip  
External pocket



Ramesh Shotham, Germany



## DOUMBEKS

MEINL Doumbeks come from the same geographical points of origin as the darbukas, and are a favourite choice of drum for percussionists world-wide. Our doumbeks feature an ergonomic, Egyptian-style rounded rim with internal tuning lugs and a synthetic head. The bearing edge is carefully machined to assure consistent tuning. The doumbeks are well suited for fast finger-roll techniques and have a strong projection. The shells are constructed from various materials, each offering a wide range of timbres, weights and visual aesthetics.



### COPPER DOUMBEK, HAND ENGRAVED

The copper shell of this MEINL Doumbek is hand engraved for a stunning look. A very traditionally looking and sounding instrument.

**Size** 8 1/2" x 17 1/8"  
**Material** Copper  
**Features** Synthetic head  
 Hand engraved shell

**Includes** Carrying bag  
 Spare head  
 Tuning key



HE-3012

### ALUMINUM DOUMBEK, HAND HAMMERED

The aluminum shell of this MEINL Doumbek is completely hand hammered for a most appealing look.

**Size** 8 1/2" x 17 1/8"  
**Material** Aluminum  
**Features** Synthetic head  
 Hand hammered shell

**Includes** Carrying bag  
 Spare head  
 Tuning key



HE-3030

### ALUMINUM DOUMBEK, WOOD COVERED

The shell of this MEINL Doumbek is made from aluminum and is completely covered with a layer of the finest wood. Combined with its synthetic head, it ensures a warm and smooth tone with lots of low end and less ringing highs.

**Size** 8 1/2" x 17 1/8"  
**Material** Aluminum  
**Features** Synthetic head  
 Wood covered shell

**Includes** Carrying bag  
 Spare head  
 Tuning key



HE-3400

## ALUMINUM DOUMBEKS

Hand made entirely of aluminum, the MEINL Doumbek is outstanding in sound and quality reaching from resonant lows to ringing highs. Available as black vinyl covered or copper finished versions.



HE-3000

HE-3020

**Size** 8 1/2" x 17 1/8"  
**Material** Aluminum  
**Feature** Synthetic heads

**Includes** Carrying bag  
 Spare head  
 Tuning key

### PROFESSIONAL DOUMBEK BAG

The MEINL Doumbek Bag is made from heavy duty padded nylon with reinforced stitching and is equipped with a double-slide zipper, a padded shoulder strap, and a carrying grip. It protects your instruments and provides hassle free transportation.



Carrying grip

MDOB

Additional upright zipper

Padded shoulder strap

**Material** Heavy duty padded nylon  
**Features** Double-slide zipper  
 Additional upright zipper  
 Padded shoulder strap  
 Carrying grip  
 External pocket

## PROFESSIONAL DOUMBEK STAND

The MEINL Doumbek Stand was designed to enable incorporating a Doumbek into a percussion- or drum set up. An adjustable, foam padded ring holds the Doumbek Drum firmly and prevents it from sliding or falling down. It can be angled and is fully height adjustable.

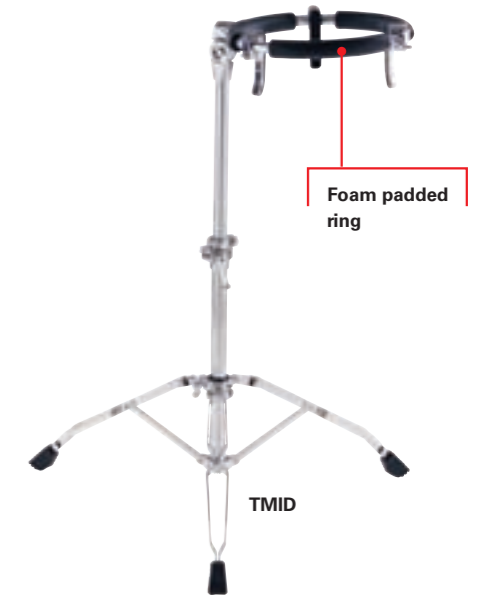

Foam padded ring

TMID

**Material** Chrome plated steel  
**Features** Foam padded ring  
 Fully height- and angle adjustable  
 Double braced tripod legs

**Includes** Allen wrench  
 Memory lock

Rüdiger Maul, Germany (Faun)







## DARBUKAS

MEINL Darbukas are made in the tradition of the original, esoteric goblet-shaped drums found in music from Eastern Europe, the Middle East and Southern Asia. Our darbukas are constructed from thin shells in various metals, each metal giving the different models their special timbre. The head is secured and tuned with external rings set close to the shell, in the Turkish-style. Light yet powerful, the darbukas have a deep full bass. They are well suited for high-pitched snapping sounds as well as a wide range of articulated "dum" and "tak" strokes.

### ALUMINUM DARBUKAS, PLAIN

These Turkish style MEINL Darbukas feature fat lows and ringing highs with a wide range in between.



**Sizes** HE-100 = 5 1/3" x 9 1/4"  
HE-101 = 5 7/8" x 11"  
HE-102 = 6 1/2" x 12 3/4"  
HE-103 = 7 1/4" x 13 1/3"  
HE-104 = 8" x 14 1/2"

**Material** Aluminum  
**Feature** Synthetic heads  
**Includes** Tuning key

### ALUMINUM DARBUKAS, HAND HAMMERED

These MEINL Turkish style Darbukas have a beautifully hand hammered shell. They offer resonant lows and ringing highs with a wide range in between.

**Sizes** HE-113 = 7 1/4" x 13 1/3"  
HE-114 = 8" x 14 1/2"

**Material** Aluminum  
**Features** Synthetic heads  
Hand hammered shells  
**Includes** Tuning key

### ALUMINUM JINGLE DARBUKAS, HAND HAMMERED

These MEINL Aluminum Darbukas feature a beautifully hand hammered shell and built in jingles which adds a nice rattling effect and enhances their sound spectrum tremendously.



**Sizes** HE-314 = 8" x 14 1/2"  
HE-315 = 8 1/4" x 16"

**Material** Aluminum  
**Features** Built in jingles  
Synthetic heads  
Hand hammered shells  
**Includes** Tuning key



### COPPER DARBUKAS, BRASS PLATED, HAND HAMMERED

These unique instruments are made entirely of copper with a brass plated- and hand hammered shell. Strong high tones with resonant lows.

**Sizes** HE-214 = 7 1/2" x 14 3/4"  
HE-215 = 7 7/8" x 15 1/2"

**Material** Copper  
**Features** Synthetic heads  
Hand hammered shells  
**Includes** Carrying bag  
Spare head  
Tuning key

Brass plated and hand hammered shell



### COPPER DARBUKAS, HAND ENGRAVED

The beautifully hand engraved shell of this copper darbuka is outstanding in sound and look!

**Sizes** HE-204 = 7 1/2" x 14 3/4"  
HE-205 = 7 7/8" x 15 1/2"

**Material** Copper  
**Features** Natural rawhides  
Hand engraved shells  
**Includes** Carrying bag  
Spare head  
Tuning key

Natural rawhide



### PROFESSIONAL DARBUKA BAG

The MEINL Darbuka Bag is made from heavy duty padded nylon with reinforced stitching and is equipped with a double-slide zipper, a padded shoulder strap, and a carrying grip. It protects your instruments and provides hassle free transportation.





## HEADLINER® SERIES DANCING DRUMS



The MEINL Headliner® Series Dancing Drums are the perfect instruments for educational or street percussion. They are made from high quality materials and produce great sounds. A great gift idea as well.

### FIBERGLASS DANCING CONGA



HC301MC

- Size** 8 1/2" x 24" tall
- Material** Premium fiberglass
- Features** 7 mm strong tuning lugs  
2.2 mm rounded rim  
Black powder coated hardware
- Includes** Nylon strap  
Tuning key
- Colour** MC = Multi colour

### FIBERGLASS DANCING DJEMBE



HDJ400MC

- Size** 12" x 22 3/4" tall
- Material** Premium fiberglass
- Features** 7 mm strong tuning lugs  
2.2 mm rounded rim  
Black powder coated hardware
- Includes** Nylon strap  
Tuning key
- Colour** MC = Multi colour

### FIBERGLASS FAMILY DRUMS



HFDD1MC

HFDD2MC

HFDD3MC

- Sizes** HFDD1BK = 8 3/4", tall 13 1/2"  
HFDD2R = 8", tall 11 1/4"  
HFDD3Y = 7 1/2", tall 9 3/4"
- Material** Premium fiberglass
- Features** 8 mm strong tuning lugs  
Traditional rim  
Black powder coated hardware
- Includes** Nylon strap  
Tuning key
- Colour** MC = Multi colour

### FIBERGLASS MINI DANCING DJEMBE



HDJ200MC

- Size** 8" x 14 1/3" tall
- Material** Premium fiberglass
- Features** Traditional rim  
Black powder coated hardware  
Floatune Tuning System
- Includes** Nylon strap  
Tuning key
- Colour** MC = Multi colour

Eye catching multi colour finish

## PERCUSSION WORKSTATION

When it comes to ease of access and playability, the MEINL Percussion Workstation is the ultimate solution. Made with great attention to detail, the MEINL Percussion Workstation has been designed to be customized according to the player's demand. Depending on any given space situation, it can be expanded or reduced to fit the particular needs.

With the majority of its colour being black, the MEINL Percussion Workstation will blend in nicely with the overall stage design and won't interfere with the lighting- and design engineers' concepts.

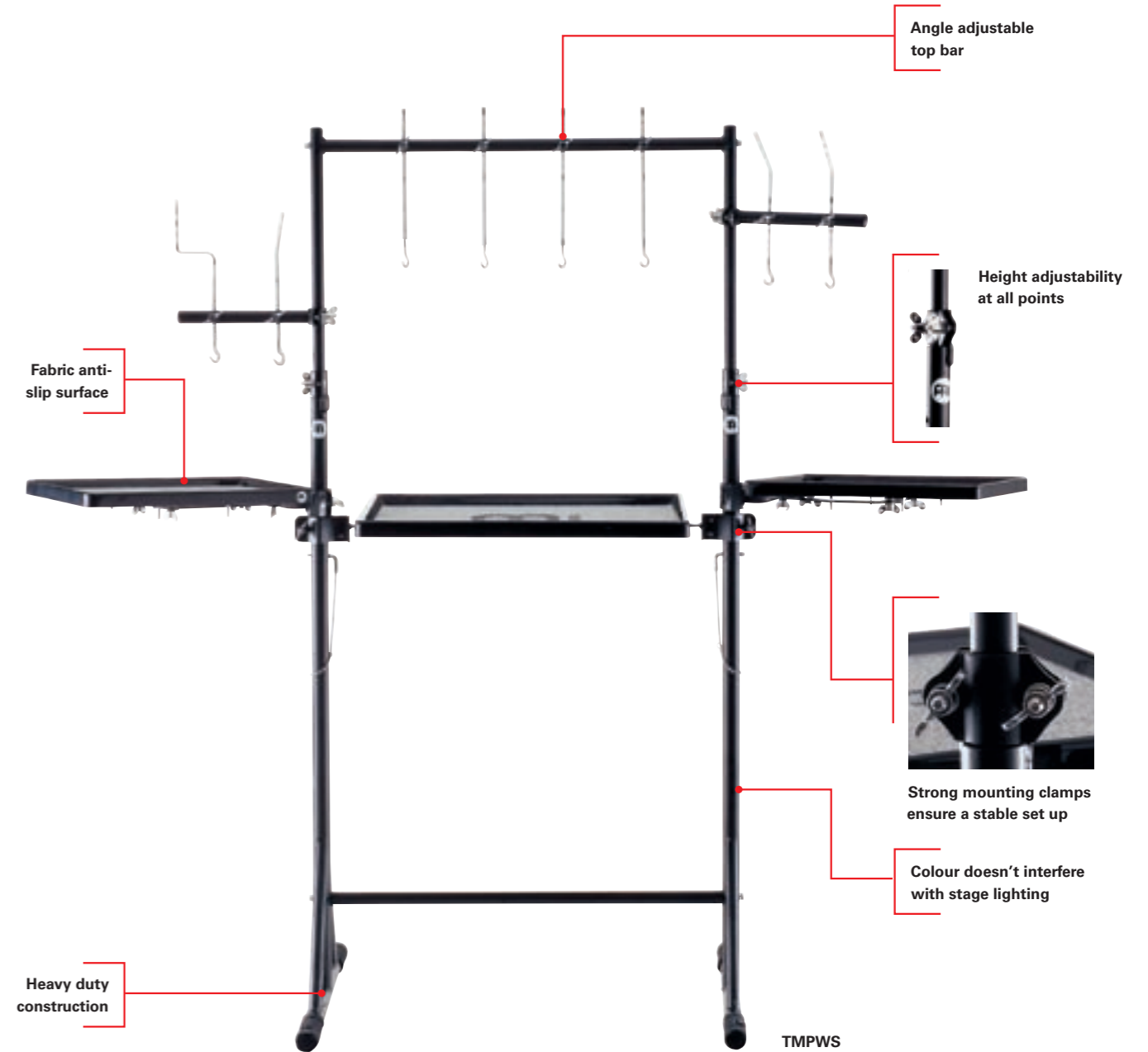

- Material** Black powder coated steel
- Features** Fully height adjustable  
Angle adjustable top bar  
Fabric anti-slip surface  
Heavy duty construction  
Infinitely expandable  
Fabric anti-slip surfaces  
Colour doesn't interfere with stage lighting

- Includes** 1 pc 22" x 24" padded fiberglass percussion table  
2 pcs 18" x 12" padded fiberglass percussion tables (attachable)  
1 pc 30" vertical bar  
2 pcs 15" vertical bars (attachable)  
4 pcs straight rods with hook  
3 pcs angled rods with hook  
1 pc Z-shaped rod with hook





## PERCUSSION TABLES

The MEINL Percussion Tables are made from durable fiberglass and offer enough room for all common hand percussion instruments. It can be attached to all common stands. Through its innovative design the angle of the table can be adjusted.

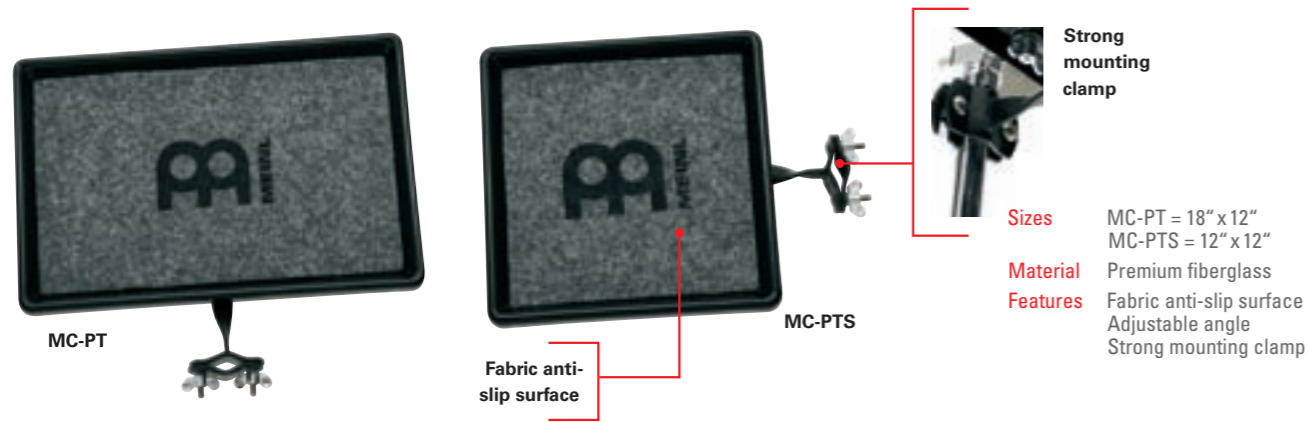

**Sizes** MC-PT = 18" x 12"  
MC-PTS = 12" x 12"  
**Material** Premium fiberglass  
**Features** Fabric anti-slip surface  
Adjustable angle  
Strong mounting clamp

## PERCUSSION STAND

The MEINL Percussion Stand is a universal device which offers a variety of set up solutions for both drummers and percussionists. It is fully height adjustable and features both quick locks and memory locks for a quick set up.

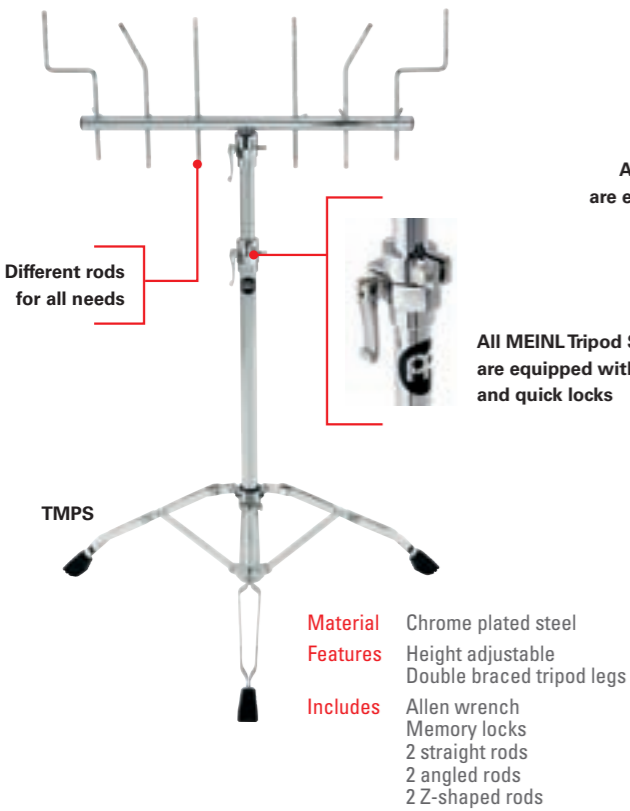

**Material** Chrome plated steel  
**Features** Height adjustable  
Double braced tripod legs  
**Includes** Allen wrench  
Memory locks  
2 straight rods  
2 angled rods  
2 Z-shaped rods

## PERCUSSION TABLE STAND

The MEINL Percussion Table Stand offers enough room for all common hand percussion instruments. It is fully height adjustable and has a fabric anti-slip surface.

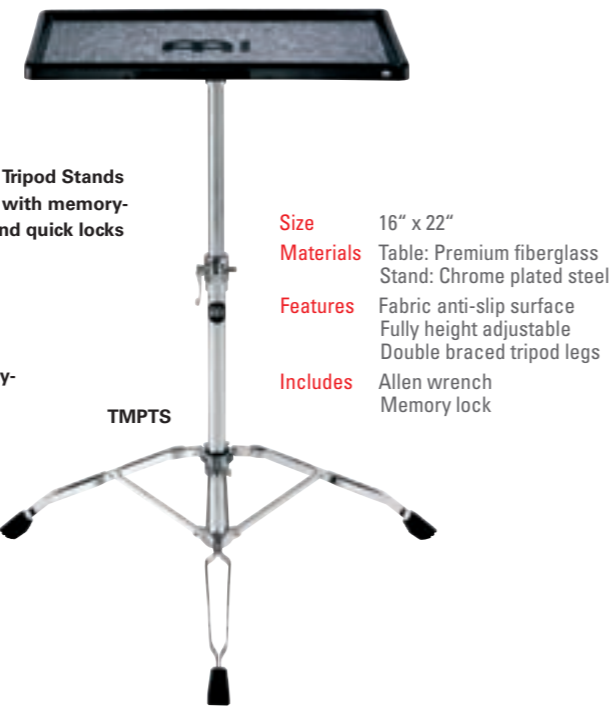

**Size** 16" x 22"  
**Materials** Table: Premium fiberglass  
Stand: Chrome plated steel  
**Features** Fabric anti-slip surface  
Fully height adjustable  
Double braced tripod legs  
**Includes** Allen wrench  
Memory lock

## PEDAL MOUNT

The MEINL Pedal Mount fits on all common bass drum pedals and firmly holds cowbells, blocks, or tambourines. It is height adjustable and contains metal spikes attached to the bottom of the legs, holding the entire unit in place without movement.

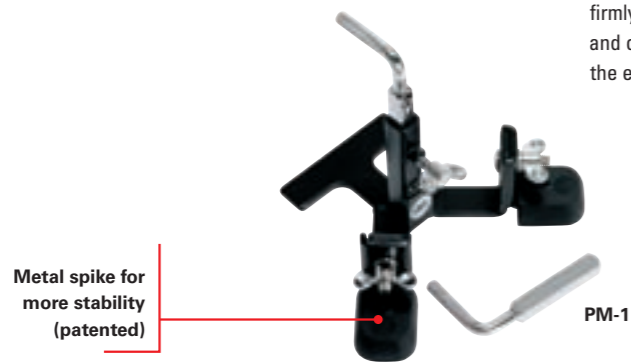

**Material** Black powder coated steel  
**Features** Height adjustable legs  
Metal spikes attached to the bottom of the legs  
**Includes** 2 differently sized L-rods

## ORIGINAL MEINL HARDWARE

A professional mounting system requires stability and flexibility. The Original MEINL Hardware features the highest quality workmanship to provide a large variety of set up solutions for both percussionists and drummers alike. A system of well thought out clamps, holders, rods, and attachments for literally any set up or space situation.

## MULTI CLAMP, ONE MOUNT

The MEINL Multi Clamp easily attaches to any common stand. Its unique feature is the length adjustability to fit any given space situation. It holds one rod.

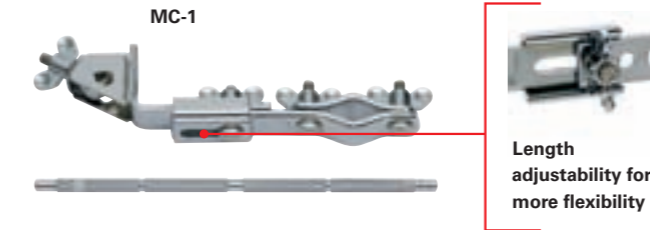

**Material** Chrome plated steel  
**Features** Length adjustable  
Strong mounting clamp  
**Includes** Straight rod

## MULTI CLAMP, TWO MOUNTS

The MEINL Multi Clamp easily attaches to any common stand. Its unique feature is the length adjustability to fit any given space situation. It holds two rods.

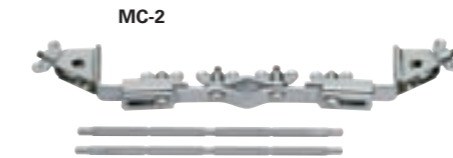

**Material** Chrome plated steel  
**Features** Length adjustable  
Strong mounting clamp  
**Includes** 2 straight rods

## MULTI CLAMP, FOUR MOUNTS

The MEINL Multi Clamp easily attaches to any common stand. Its unique feature is the length adjustability to fit any given space situation. It holds four rods.

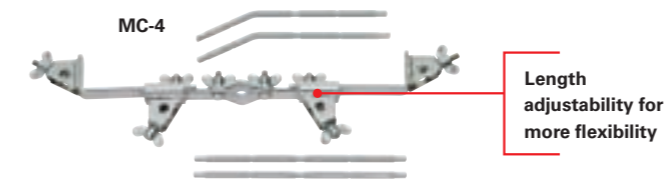

**Material** Chrome plated steel  
**Features** Length adjustable  
Strong mounting clamp  
**Includes** 2 straight rods  
2 angled rods

## CLAMP

The MEINL Percussion Clamp attaches to the lug of a conga, bongo, or djembe for mounting an additional cowbell, block, or tambourine.

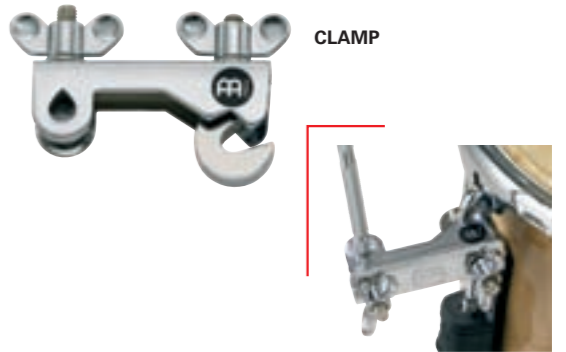

**Material** Chrome plated steel  
**Feature** Compact and solid design

## MOUNTING BAR, 6 PCS.

The MEINL Mounting Bar can easily be attached to any stand. It's ideal for expanding your percussion or drum set up.

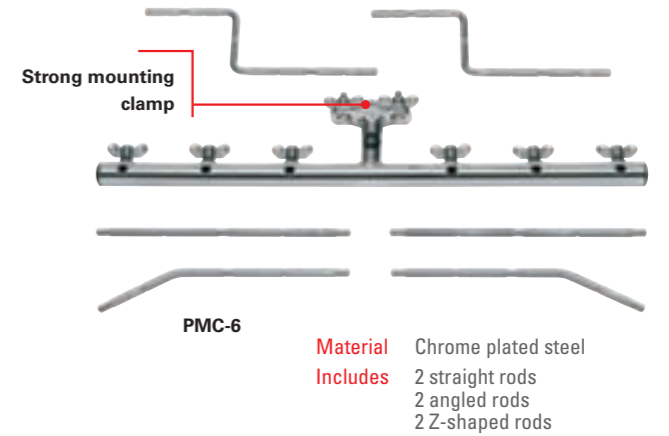

**Material** Chrome plated steel  
**Includes** 2 straight rods  
2 angled rods  
2 Z-shaped rods

## RODS

A variety of differently shaped rods can hold several mountable hand percussion instruments.

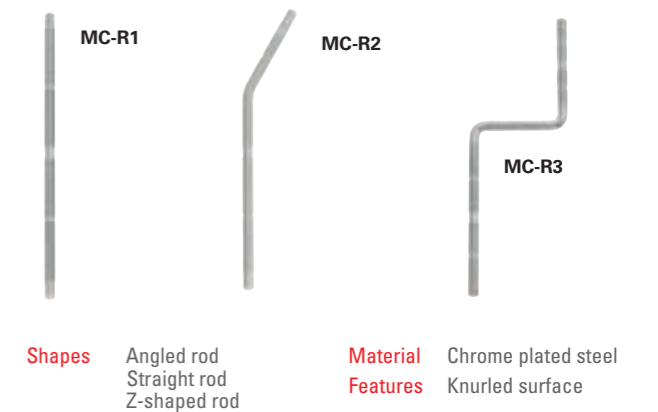

**Shapes** Angled rod  
Straight rod  
Z-shaped rod  
**Material** Chrome plated steel  
**Features** Knurled surface



## CANDELA PERCUSSION CYMBALS

The MEINL Candela Series of Percussion Cymbals have been designed to meet the specific requirements of today's percussionists. They are extremely thin cymbals which produce soft, exotic tones, are tonally matched and respond even at lower volumes.

### PERCUSSION CRASHES

The crashes are thin, tonally matched cymbals which can be played by hand or hit with a stick. They respond fast and decay quickly.

**CA16C**  
Hand hammered

**CA14C**  
Fast response and attack

**Sizes** 14"  
16"

**Material** B20 Bronze

**Features** Hand hammered  
Brilliant finish  
Fast response and attack  
Quick decay

### PERCUSSION SPLASH

The percussion splash is an extremely thin, quick sounding cymbal – perfect for fast percussive accents.

**CA10S**  
Brilliant finish

**Quick response when hit by a hand**

**Size** 10"

**Material** B20 Bronze

**Features** Hand hammered  
Brilliant finish  
Fast response and attack  
Quick decay

### TIMBALE CRASH/RIDE

It's the perfect cymbal for timbale playing. It has a loud, penetrating bell and a full, warm crash sound.

**CA18CR**  
Cutting bell sound

**Great crash sound**

**Size** 18"

**Material** B20 Bronze

**Features** Hand hammered  
Brilliant finish  
Cutting bell sound  
Great crash sound

### PERCUSSION JINGLE BELL

A great cymbal with an exotic sound. Six pairs of jingles attached to this cymbal produce a rattling effect.

**CA14PJB**  
Built in jingles

**Made from B8 Bronze**

**Size** 14"

**Material** B8 Bronze

**Features** Precisely hammered  
Built in jingles

## DESIGNER CYMBAL BAGS

**NEW**

The MEINL 22" Cymbal Bags are available in six different finishes. Two external compartments hold cymbals up to 15" in diameter and allow storage of sticks and other drum accessories.



Individual compartments prevent from direct metal to metal contact



**Size** 22"

**Material** Heavy duty padded nylon

**Features** External compartment  
Padded dividing pads  
Padded shoulder strap  
Carrying grip

**Colours** Black, Earth Camouflage, Leopard, Original Camouflage, Urban Camouflage, Zebra

## DESIGNER STICK BAGS

**NEW**

The MEINL Designer Stick Bags are available in six different finishes. Four spacious sections for drumsticks and a separate compartment for drum accessories.



**Material** Heavy duty padded nylon

**Features** External pockets  
Shoulder straps  
Extension straps

**Colours** Black, Earth Camouflage, Leopard, Original Camouflage, Urban Camouflage, Zebra

## DRUMSTICK HOLDER

The MEINL Drumstick Holder firmly attaches to any common stand and stores a number of drumsticks, mallets, brushes and other accessories in its roomy pouch for ready access when needed.



**Materials** Chrome plated steel  
Black textile pouch

**Feature** Strong mounting clamp

## CYMBAL HOLDER

This MEINL holder comfortably places any cymbal within a drum or percussion set up.

**Material** Chrome plated steel

**Features** Knurled surface  
Felt washers

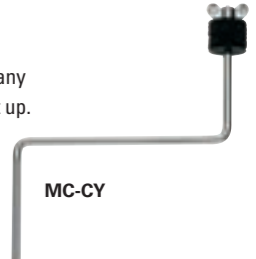

## CYMBAL STACKERS

The MEINL Cymbal Stackers enable a space saving set up of various cymbals on top of each other.

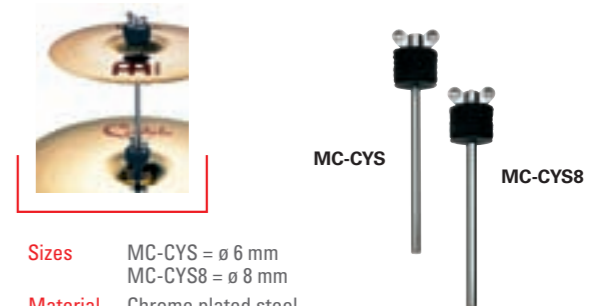

**Sizes** MC-CYS = ø 6 mm  
MC-CYS8 = ø 8 mm

**Material** Chrome plated steel

**Feature** Felt washers

## DELUXE STICK BAG

The MEINL Deluxe Stick Bag offers some special features. Spacious sections for drumsticks featured with zippered clear window pockets and two external pockets for extra gear.

**NEW**

**Material** Padded synthetic leather

**Features** External pockets  
Shoulder straps  
Elastic cord attachments





## RITUAL DRUMS

| Model No.             | Size   | Material | Features | SPARE PARTS  |        |        |              | Page |
|-----------------------|--------|----------|----------|--------------|--------|--------|--------------|------|
|                       |        |          |          | Head         | Rim    | Lug    | Bracket      |      |
| <b>TALKING DRUM</b>   |        |          |          |              |        |        |              |      |
| TD7                   | 7 1/2" | •        | •        | HEAD-35      | RIM-25 |        |              | 117  |
| <b>BATAS</b>          |        |          |          |              |        |        |              |      |
| BA1                   | 5 1/4" | •        | •        | HEAD-07      | RIM-04 | LUG-12 |              | 119  |
| BA1                   | 8"     | •        | •        | HEAD-08      | RIM-05 | LUG-12 |              | 119  |
| BA2                   | 5 3/4" | •        | •        | HEAD-09      | RIM-06 | LUG-12 |              | 119  |
| BA2                   | 8 3/4" | •        | •        | HEAD-10      | RIM-07 | LUG-12 |              | 119  |
| BA3                   | 6 3/4" | •        | •        | HEAD-11      | RIM-08 | LUG-12 |              | 119  |
| BA3                   | 12"    | •        | •        | HEAD-12      | RIM-09 | LUG-12 |              | 119  |
| <b>WOOD CONGUITAS</b> |        |          |          |              |        |        |              |      |
| HCG89                 | 8"     | •        | •        | HEAD-05      | TTR-05 | LUG-11 | HDBRACKET-02 | 119  |
| HCG89                 | 9"     | •        | •        | HEAD-06      | TTR-08 | LUG-11 | HDBRACKET-02 | 119  |
| <b>TAMBORA</b>        |        |          |          |              |        |        |              |      |
| MTA1                  | 11"    | •        | •        | TS-B-09 (NT) | RIM-03 | LUG-10 | BRACKET-06   | 119  |
| MTA1                  | 11"    | •        | •        | TS-B-10 (WH) |        | LUG-10 | BRACKET-06   | 119  |

## DOUMBES/DARBUKAS

|                                 |        |   |   |              |  |  |  |     |
|---------------------------------|--------|---|---|--------------|--|--|--|-----|
| <b>COPPER DOUMBES</b>           |        |   |   |              |  |  |  |     |
| HE-3012                         | 8 1/2" | • | • | HE-HEAD-3000 |  |  |  | 122 |
| <b>ALUMINUM DOUMBES</b>         |        |   |   |              |  |  |  |     |
| HE-3030                         | 8 1/2" | • | • | HE-HEAD-3000 |  |  |  | 122 |
| HE-3400                         | 8 1/2" | • | • | HE-HEAD-3000 |  |  |  | 122 |
| HE-3020                         | 8 1/2" | • | • | HE-HEAD-3000 |  |  |  | 123 |
| HE-3000                         | 8 1/2" | • | • | HE-HEAD-3000 |  |  |  | 123 |
| <b>ALUMINUM DARBUKAS</b>        |        |   |   |              |  |  |  |     |
| HE-100                          | 5 1/3" | • | • | HE-HEAD-100  |  |  |  | 124 |
| HE-101                          | 5 7/8" | • | • | HE-HEAD-101  |  |  |  | 124 |
| HE-102                          | 6 1/2" | • | • | HE-HEAD-102  |  |  |  | 124 |
| HE-103                          | 7 1/4" | • | • | HE-HEAD-103  |  |  |  | 124 |
| HE-104                          | 8"     | • | • | HE-HEAD-104  |  |  |  | 124 |
| HE-113                          | 7 1/4" | • | • | HE-HEAD-103  |  |  |  | 124 |
| HE-114                          | 8"     | • | • | HE-HEAD-104  |  |  |  | 124 |
| <b>ALUMINUM JINGLE DARBUKAS</b> |        |   |   |              |  |  |  |     |
| HE-314                          | 8"     | • | • | HE-HEAD-104  |  |  |  | 124 |
| HE-315                          | 8 1/4" | • | • | HE-HEAD-315  |  |  |  | 124 |
| <b>COPPER DARBUKAS</b>          |        |   |   |              |  |  |  |     |
| HE-214                          | 7 1/2" | • | • | HE-HEAD-214  |  |  |  | 125 |
| HE-215                          | 7 7/8" | • | • | HE-HEAD-215  |  |  |  | 125 |
| HE-204                          | 7 1/2" | • | • | HE-HEAD-204  |  |  |  | 125 |
| HE-205                          | 7 7/8" | • | • | HE-HEAD-205  |  |  |  | 125 |

## DANCING DRUMS

|  |        |   |  |            |           |          |              |     |
|--|--------|---|--|------------|-----------|----------|--------------|-----|
| <b>FIBERGLASS DANCING CONGA</b>        |        |   |  |            |           |          |              |     |
| HC301                                  | 8 1/2" | • |  | HHEAD8,5   | HRIM8,5   | HDCLUG   | HDBRACKET-02 | 126 |
| <b>FIBERGLASS DANCING DJEMBE</b>       |        |   |  |            |           |          |              |     |
| HDJ400                                 | 12"    | • |  | HHEAD12    | HRIM12    | HDLUG    | HDBRACKET-02 | 126 |
| <b>FIBERGLASS MINI DANCING DJEMBES</b> |        |   |  |            |           |          |              |     |
| HDJ200                                 | 8"     | • |  | HHEADJ8    | HRIMJ8    | HD200LUG |              | 126 |
| <b>FIBERGLASS FAMILY DRUMS</b>         |        |   |  |            |           |          |              |     |
| HFDD1                                  | 8 3/4" | • |  | HHEADHFDD1 | HRIMHFDD1 | HFDDLUG  | HFDDBRACKET  | 126 |
| HFDD2                                  | 8"     | • |  | HHEADHFDD2 | HRIMHFDD2 | HFDDLUG  | HFDDBRACKET  | 126 |
| HFDD3                                  | 7 1/2" | • |  | HHEADHFDD3 | HRIMHFDD3 | HFDDLUG  | HFDDBRACKET  | 126 |
| <b>OTHER PARTS</b>                     |        |   |  |            |           |          |              |     |
| A Go Go Bell Holder                    |        |   |  | STBAGH     |           |          |              |     |
| Tuning Key                             |        |   |  | KEY-08     |           |          |              |     |

# NINO® PERCUSSION



## DIRECTORY

| PRODUCT GROUP     | PAGE |
|-------------------|------|
| SHAKE'N PLAY      | 134  |
| ABS DRUMS         | 136  |
| HAND PERCUSSION   | 138  |
| NINO® SETS        | 147  |
| BOTANY SHAKERS    | 148  |
| NINO® RHYTHM SETS | 150  |
| DJEMBES           | 152  |
| CAJON             | 154  |
| FRAME DRUMS       | 154  |
| BONGOS            | 155  |
| CONGA SETS        | 156  |
| SPARE PARTS       | 158  |
| SAFETY            | 159  |

## FIRST MOVE

The new generation of musical instruments for early childhood education.

NINO® instruments meet exactly the requirements of early childhood education and are perfectly suitable for use in kindergartens, schools, music therapy, and for musical activities at home.

Easy handling and an appealing design are standard for all NINO® instruments. They are noteworthy due to their professional features, great sounds and their outstanding quality. The strong, childproof workmanship guarantees years of trouble-free use of all NINO® instruments.





# SHAKE'N PLAY

**NEW**

The MEINL Shake'n Play is a sound-based memory game for two to four children ages three years and up, and fun for the entire family. Sixteen identical shakers make eight matched pairs. The object of the game is to find the pairs by remembering the sounds and positions on the board. Shake'n Play is a good development game and certified child-safe by the LGA.



NINO526

Images on bottom ensure correct match

- Materials** Plastic shakers  
Base out of Rubber Wood (*Hevea brasiliensis* Muell.-Arg.)
- Includes** 16 shakers (8 pairs)  
Game guide (in 8 languages)  
Wooden base
- Colour** Orange

## SHAKE'N PLAY

game guide

**Who can find the most pairs?**  
Type of game: Memory game  
Contents: 16 shakers (8 pairs)  
1 game board  
1 game guide

**Advice for parents**  
To begin, it is often helpful for young first-time players to listen carefully to all the sounds first, in order to identify the different tones.

**Setting up**  
Before the game begins the 16 shakers are shuffled and placed, with the sticker face downwards on the game board.

**Aim of the game**  
Every player tries to collect as many pairs as possible.

**How to play**  
The youngest child begins by taking a shaker and shaking it so all players can hear the sound. Then a second shaker is selected and shaken and the two tones compared. If a correctly matching pair of shakers is found then the player may keep the shakers and may try their luck again. If the tones of the two selected shakers are different then the player replaces the shakers on the game board and the next player continues. To ensure that correct shaker pairs are found, each respective pair is marked on the underside with an instrument sticker. Any confusion is therefore impossible.

**End of game**  
The game ends when there are no more shakers left on the game board. The winner is the player with the most shakers.



**FUN FOR THE ENTIRE FAMILY**



Certified child-safe by the LGA

Game guide (in 8 languages)





## ABS DRUMS

The colourful NINO® ABS Drums are not only durable, they also have a powerful sound. Shells made from ABS plastic and synthetic heads guarantee great stability and a long life. With their low weight of about two pounds and their outstanding workmanship, NINO® ABS Drums are also perfectly suitable for toddlers.

## ABS DJEMBES



## ABS BONGOS



## ABS HAND DRUMS

The multi-coloured NINO® ABS Hand Drums offer more than just tonal variety. The unbreakable shells and durable synthetic heads ensure years of trouble-free use.



## ABS TAMBOURINES

The NINO® ABS Tambourines offer enhanced sound options due to attached jingle pairs.

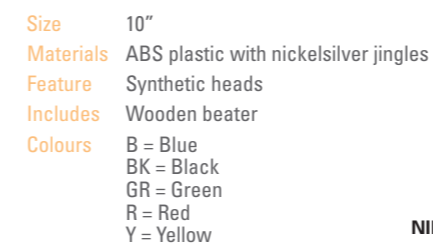



## WOOD TAMBOURINES

The NINO® Wood Tambourines feature a sturdy wooden frame along with a nice sparkling sound. They are available in a one row construction with 8 nickelsilver plated steel jingle pairs, or as a two row model with 16 nickelsilver plated steel jingle pairs.



**Size** 10" diameter  
**Materials** Jingles: Nickelsilver plated steel  
 Wooden frame  
**Feature** 1 or 2 row versions available  
**Includes** Hole for better grip

## HEADED WOOD TAMBOURINES

With nickelsilver plated steel jingles and plastic heads firmly attached to the tambourine, this instrument delivers a subtle and gentle tone.



**Size** 10" diameter  
**Materials** Jingles: Nickelsilver plated steel  
 Plastic heads  
 Wooden frame  
**Feature** 1 or 2 row versions available  
**Includes** Firmly attached

## TRIANGLES

NINO® Percussion offers three tonally matched triangles. Each have a strong sound with a long sustain.

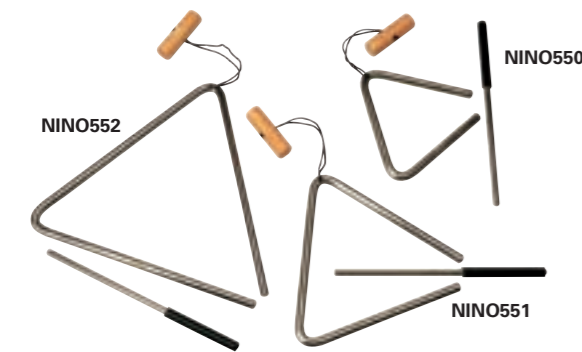

**Sizes** 4"  
 6"  
 8"  
**Material** Steel  
**Feature** Wooden holder with braided nylon strap  
**Includes** Metal beater with rubber padded grip

## RACKET TAMBOURINE

The NINO® Racket Tambourine features a sturdy rattan frame along with a nice sparkling sound. It is available as a one row construction with 9 aluminum jingle pairs. An ergonomically shaped handle makes it perfect for children hands.

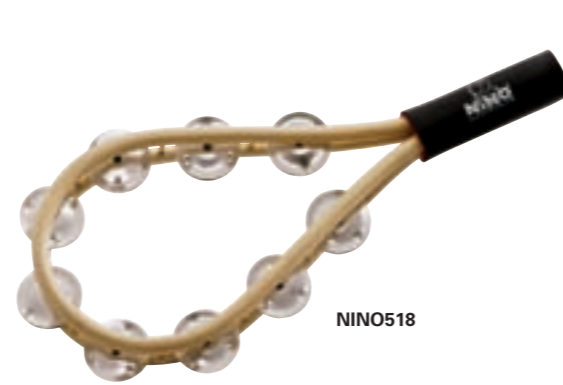

**Materials** Frame: Rattan  
 Jingles: Aluminum  
**Features** Ergonomically shaped and padded handle

## A-GO-GO BELL

The NINO® A-Go-Go Bell is perfectly sized for children. It is handmade from high quality steel and produces a loud bell sound.

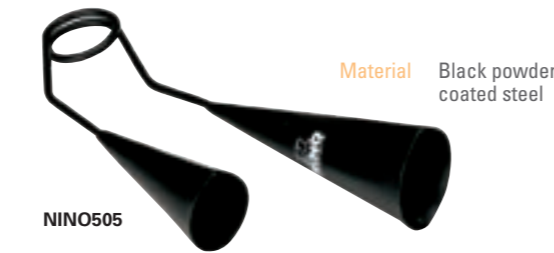

**Material** Black powder coated steel

## CABASAS

The NINO® Cabasas are made from a wooden cylinder covered with a rippled metal plate, which is surrounded by a net of metal beads. Holding the handle with one hand and scratching the metal beads with the other hand on the metal plate creates the classic cabasa sound. The smaller 2" model was especially designed for a child's hand.

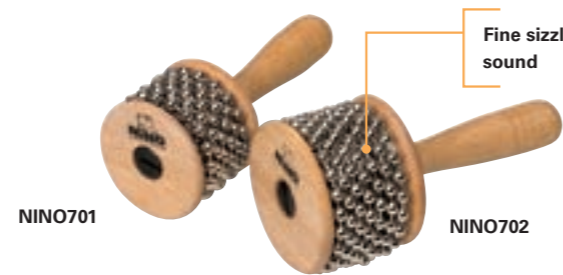

**Sizes** Small  
 Medium  
**Material** Steel chain and cylinder  
**Feature** Ergonomically shaped wooden handle  
**Includes** Fine sizzle sound

## CHIMES

The NINO® Chimes can be mounted on a cymbal stand, or held by the wooden frame. The 12 bars of the NINO® Chimes are made from a premium aluminum alloy and create a very full and rich sound.

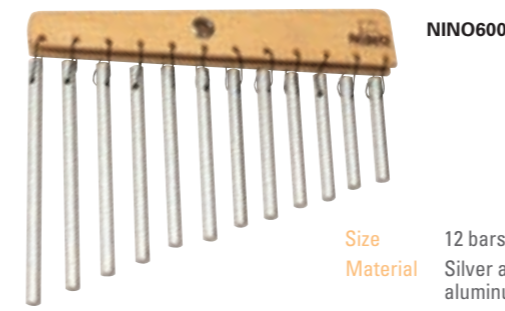

**Size** 12 bars  
**Material** Silver anodized aluminum alloy

## HAND CHIMES

With bars made from a silver anodized aluminum alloy, the NINO® Hand Chimes produce a full and rich sound.



**Size** 12 bars  
**Material** Silver anodized aluminum alloy

## CYMBAL PAIRS

NINO® Cymbal Pairs are made in Germany from premium alloys. Different sizes are available in bronze, brass, or nickel silver. All cymbal pairs are tonally matched and are equipped with a leather strap.



**Sizes** 7"/17.5 cm  
 8"/20.0 cm  
**Materials** Bronze, brass, or nickel silver  
**Includes** Leather straps

## ENERGY CHIMES

These NINO® instruments have a very cutting "ping" sound. The free floating bars create a very long sustain. NINO® offers three different pitched Energy Chimes, as well as a model with three bars.



**Sizes** Small  
 Medium  
 Large  
 3 rows  
**Material** Silver anodized aluminum alloy  
**Includes** Wooden beater

## TENOR GONG

Children love the NINO® Tenor Gong which is hand made from a special alloy. Its smooth and relaxing tone reveals magic.



**Size** 12"  
**Material** Special alloy  
**Feature** Smooth and relaxing tone  
**Includes** Holder  
 Beater

## CYMBALS

These excellent sounding NINO® Cymbals are made in Germany. They are a high quality product and perfect for music education.



**Sizes** 12"/30.5 cm  
 14"/35.5 cm  
**Material** Nickel silver  
**Includes** Leather strap

## HAND PERCUSSION



## JINGLE STICKS

The NINO® Jingle Sticks feature six pairs of nickelsilver plated jingles firmly mounted on a plastic frame with a handle. The jingle stick can be played like a tambourine, or like a drumstick on a conga, bongo, or djembe. New and interesting sounds can be achieved with this instrument.



**Materials** Jingles: Nickelsilver plated steel  
Frame: ABS

**Features** Ergonomically shaped handle  
New sound ideas

**Colours** BK = Black  
R = Red  
Y = Yellow

## MINI GUIROS

The NINO® Mini Guiros are made from high quality material. The sound is achieved by scratching the different surfaces of the guiro.



**Size** Mini

**Includes** Wooden scraper

**Colours** BK = Black  
R = Red

## PLASTIC MARACAS

The NINO® Plastic Maracas are known for their stability, versatility, and strong, projecting sound.



**Material** Plastic

**Features** Ergonomically shaped handle  
Sold as pairs

**Colours** GR = Green  
R = Red  
Y = Yellow



## WOOD EGG MARACAS

Maracas are used for any style of music and are one of the most popular rhythm instruments worldwide. The NINO® Wood Egg Maracas have a nice warm sound and come with an ergonomically shaped handle.



**Sizes** Small  
Medium

**Material** Rubber Wood  
(*Hevea brasiliensis* Muell.-Arg.)

**Features** Ergonomically shaped handle  
Sold as pairs

## WOOD MARACAS

The NINO® Wood Maracas sound very focused and have more attack.



**Sizes** Small  
Medium

**Material** Rubber Wood  
(*Hevea brasiliensis* Muell.-Arg.)

**Features** Ergonomically shaped handle  
Sold as pairs

## SKIN EGG SHAKER

The NINO® Skin Egg Shaker is entirely hand made and has a warm and mellow sound.



**Material** Natural skin

## PLASTIC EGG MARACAS

The NINO® Egg Maracas are made from a special plastic material. They have a very clear and pronounced sound and are perfect maracas for children.



**Size** 6"

**Material** Plastic

**Features** Ergonomically shaped handle  
Sold as pairs

**Colour** R = Red

## SKIN MARACAS

NINO® Skin Maracas are entirely hand made and have a warm and mellow sound.



**Size** Small

**Material** Natural skin

**Features** Mellow sound  
Ergonomically shaped wood handle  
Sold as pairs



## HAND PERCUSSION

JINGLE STICKS, MINI GUIROS, PLASTIC MARACAS  
WOOD/PLASTIC EGG MARACAS, WOOD/SKIN MARACAS, SKIN EGG SHAKER



## WOOD FROGS

The NINO® Wood Frogs have gained an enormous popularity over the last few years. Children especially love the authentic “ribbit” sound which is created by scratching the wooden beater on the frog’s back. Great fun for kids and adults.



**Sizes** Small  
Medium  
Large  
X-large

**Material** Wood

**Feature** Creates original “ribbit” sound

**Includes** Wooden scratcher

**Colour** GR = Green

## WOOD ANIMALS

The NINO® Wood Animals are great sounding miniature imitations of a grasshopper, snail, turtle and pig. Scratching the wooden beater on the surface of the instruments creates a nice guiro-like sound. Great fun for kids and adults.



**Material** Wood

**Feature** Creates guiro-like sounds

## WOOD SHAKERS

Toddlers especially love these little rhythm instruments. NINO® Natural Wood Shakers have different fillings. A cylindrical shaped shaker is available in two different sizes, as well as a square, and a triangular shaped shaker assortment.

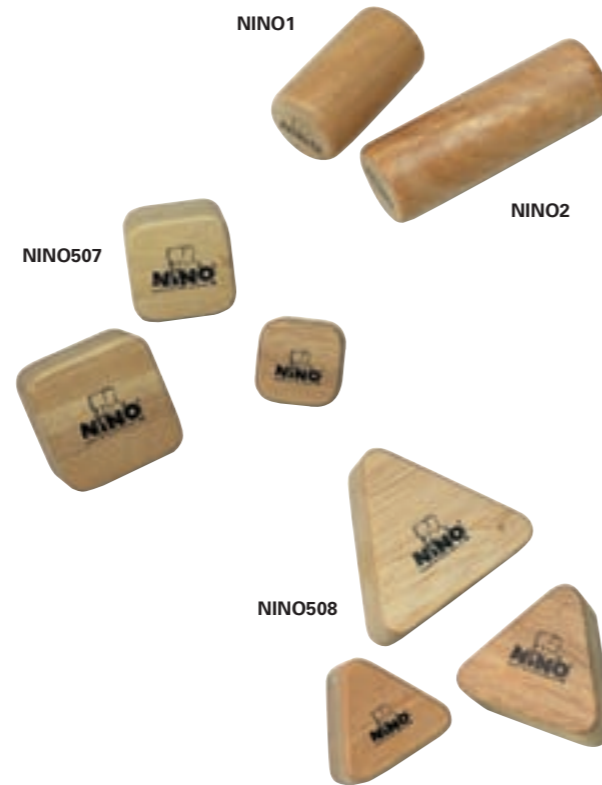

**Shapes** NINO1 = Cylindrical, small  
NINO2 = Cylindrical, large  
NINO507 = Square, 3 pcs. set  
NINO508 = Triangular, 3 pcs. set

**Material** Rubber Wood  
(*Hevea brasiliensis* Muell.-Arg.)

**Feature** Different sounding fillings

## WOOD EGG SHAKERS

NINO® Wood Egg Shakers are very handy because of their shape. They also have a great sound with various pitches depending on their size.

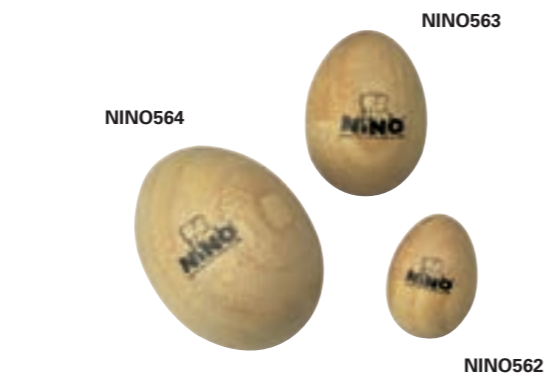

**Sizes** Small  
Medium  
Large

**Material** Rubber Wood  
(*Hevea brasiliensis* Muell.-Arg.)

## ORIENTAL WOOD TONE BLOCK

The NINO® Oriental Wood Tone Block produces a high pitched and open sound.



**Material** Rubber Wood  
(*Hevea brasiliensis* Muell.-Arg.)

**Feature** Ergonomically shaped handle

**Includes** Wooden beater

## WOOD STIRRING DRUM

The eight wooden tongues produce different pitches when they are struck separately, like playing a xylophone. By stirring in the drum with the included beater a scale can be played. The combination of a stirring drum with a handle is an original MEINL innovation.



**Material** Rubber Wood  
(*Hevea brasiliensis* Muell.-Arg.)

**Feature** Ergonomically shaped handle

**Includes** Wooden beater

## WOOD BALL STIRRING DRUM

The NINO® Wood Ball Stirring Drum is a further development of the familiar stirring drum. The instrument is based on a clever design. When playing the drum, a wooden ball fastened to a nylon string strikes the tonally matched wooden tongues and produces a harmonic sound.

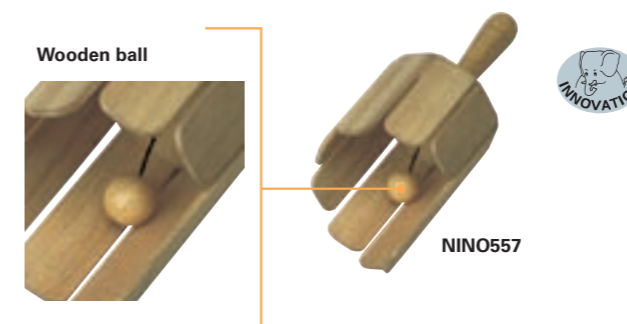

**Material** Rubber Wood  
(*Hevea brasiliensis* Muell.-Arg.)

**Feature** Ergonomically shaped handle





## WOOD CLAVES

Claves are an essential instrument in Latin music and shouldn't be missing from any percussion set up. The NINO® Wood Claves are available as regular sized models. A second pair was especially designed to fit a child's hand size.



- Sizes** Small  
Regular
- Material** Rubber Wood  
(*Hevea brasiliensis* Muell.-Arg.)
- Feature** Sold as pairs

## WOOD BLOCKS

The Wood Block is probably one of the oldest rhythm instruments and should be part of any percussion group. The NINO® Wood Blocks have an impressive sound and are available in two sizes.



- Sizes** Medium  
Large
- Material** Rubber Wood  
(*Hevea brasiliensis* Muell.-Arg.)
- Includes** Wooden beater

## WOOD A-GO-GO'S

The NINO® Wood A-go-go's are played with a wooden beater and produce a powerful sound. They can also be scratched like a guiro. These two playing styles leave room for creativity.

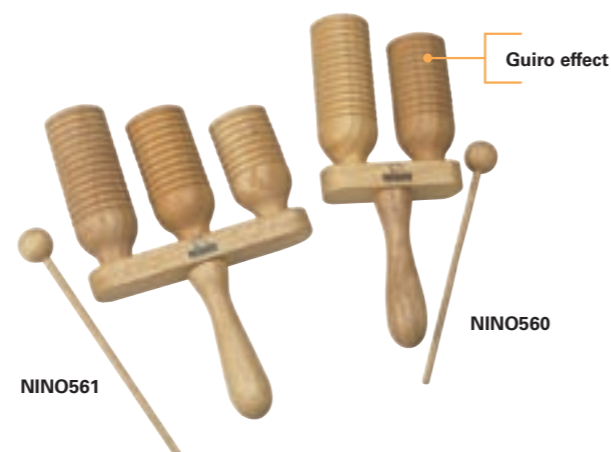

- Sizes** 2 rows  
3 rows
- Material** Rubber Wood  
(*Hevea brasiliensis* Muell.-Arg.)
- Features** Different playing options  
Ergonomically shaped handle
- Includes** Wooden beater

## WOOD TONE BLOCK

The NINO® Wood Tone Block has two tonally matched resonant chambers in the solid wooden body.



- Material** Rubber Wood  
(*Hevea brasiliensis* Muell.-Arg.)
- Feature** Tonally matched resonating bodies
- Includes** Wooden beater

## WOOD GUIRO

The guiro is an instrument which plays a very important part in any percussion set up. Striking the tonal grooves of the NINO® Wood Guiro creates many different sounds.



- Material** Rubber Wood  
(*Hevea brasiliensis* Muell.-Arg.)
- Includes** Wooden striker

## WOOD GUIRO SHAKER

The NINO® Wood Guiro Shaker is equipped with a filling and combines a shaker as well as a guiro sound in one instrument.



- Material** Rubber Wood  
(*Hevea brasiliensis* Muell.-Arg.)
- Feature** Additional shaker sound
- Includes** Wooden striker

## CAXIXI

The NINO® Caxixi produces a clear and cutting sound.



- Materials** Rattan with natural skin hide bottom

## DOUBLE SHAKER

The NINO® Double Shaker produces a clear and cutting sound with enhanced volume.



- Materials** Rattan with natural skin hide bottom

## WOODPECKER

The NINO® Woodpecker creates an amazingly realistic "woodpecker" sound. It's a great effect instrument which is also interesting for professional players who look to increase their sound arsenal.



- Material** Rubber Wood  
(*Hevea brasiliensis* Muell.-Arg.)

## GANZA SHAKERS

The NINO® Ganza Shakers produce a voluminous sound due to their size.



- Sizes** Small  
Medium
- Materials** Rattan with coconut bottom







## NINO® SETS

NINO® instruments have been designed to meet the demands of early childhood education and are perfectly suitable for the use in kindergartens, schools, music therapy and musical activities in the family. Available are two different NINO® Percussion collections which come in a durable nylon Harlekin® design bag. It's the perfect activity for small groups of up to 8 children.

### NINOSET1



- Contents**
- 1 x ABS Hand Drum 6"
  - 1 x Wooden Beater
  - 1 x Wood Shaker, large
  - 1 x Skin Maracas pair, small
  - 1 x Jingle Stick
  - 1 x Harlekin® bag

NINOSET1

### NINOSET4



Contents of NINOSET4



NINOSET4

- Contents**
- 1 x Wood Guiro
  - 1 x Caxixi
  - 1 x Wood Claves pair, small
  - 1 x Triangle, 4"
  - 1 x Egg Shaker

- 1 x Egg Shaker, small
- 1 x Botany Shaker, Banana
- 1 x Botany Shaker, Apple
- 1 x Harlekin® bag

## MUSIC BAGS

Handy bags made from durable nylon are always useful. These NINO® Music Bags are available in red and the Harlekin® design. Many separate compartments make them ideal for all kind of activities.

- Material** Nylon  
**Feature** Many compartments

- Colours** HK = Harlekin®  
 R = Red



NINO800HK

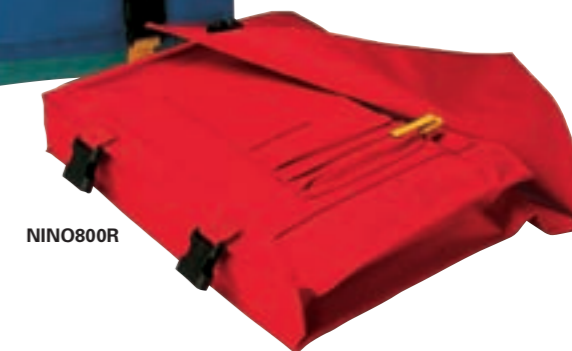

NINO800R



## BOTANY SHAKERS

The NINO® Botany Shakers are made from a high quality plastic material filled with a specially nice sounding substance. These fruit and vegetable imitations look amazingly real and create a great variety of sounds.

NINO® Botany Shakers have been tested for saliva resistance and can therefore be given to toddlers without any worries.

### “FRUIT” ASSORTMENT, 4 pcs.



**Material** Plastic  
**Feature** Botany Shaker Assortment, 4 pcs. “fruit”

NINOSSET100



### “VEGETABLE” ASSORTMENT, 4 pcs.



**Material** Plastic  
**Feature** Botany Shaker Assortment, 4 pcs. “vegetable”

NINOSSET101

### BOTANY SHAKER ASSORTMENT, 36 pcs.



**Material** Plastic  
**Feature** Botany Shaker Assortment, 36 pcs. incl. 2 baskets of each 18 pcs.

VE36-NINO536

## EGG SHAKERS

NINO® Egg Shakers are vital to every percussion collection. They have an extremely pronounced and crystal clear sound.



**Material** Plastic  
**Colours** B = Blue  
BK = Black  
GR = Green  
R = Red  
Y = Yellow

### EGG SHAKER, SMALL



NINO540MBR

**Size** Small  
**Material** Plastic  
**Colour** BR = Brown

### ASSORTMENT, 4 pcs.



NINOSSET540

**Material** Plastic  
**Sets** Egg Shaker Set 4 pcs.  
Egg Shaker Set 80 pcs. including elephant shaped basket

### ASSORTMENT, 80 pcs.



VE80-NINO540

## BALL SHAKER

The two shakers are firmly attached to each other with a strong cord. By tightly holding one ball and rhythmically swinging the other one, many sounds can be achieved.

**Material** Plastic  
**Feature** Attractive Harlekin® design



NINO509



## NINO® RHYTHM SETS

**NEW**

These two NINO® Rhythm Sets include 12 or 15 individual instruments. They are perfect for use in kindergarten, schools, or percussion groups. These collections of different instruments are the ideal way to explore the complete NINO® world of percussion and rhythm.

### RHYTHM ASSORTMENT, 12 pcs.



NINOSSET012

- Contents**
- 1 x ABS Hand Drum 12"
  - 1 x ABS Tambourine 10"
  - 1 x ABS Hand Drum 8"
  - 1 x ABS Hand Drum 6"
  - 1 x Skin Maracas pair, medium
  - 1 x Wood Block, large

- 1 x Skin Egg Shaker
- 1 x Jingle Stick, yellow
- 1 x Jingle Stick, red
- 1 x Wood Tambourine, 10"
- 1 x Wood Shaker, small

### RHYTHM ASSORTMENT, 15 pcs.

**NEW**



NINOSSET515

- Contents**
- 1 x Wood Guiro
  - 1 x Triangle, 6"
  - 1 x Plastic Egg Maracas pair, red
  - 1 x Mini Guiro
  - 1 x Egg Shaker
  - 1 x Racket Tambourine
  - 1 x Wood Claves pair, small

- 1 x Energy Chimes, medium
- 1 x Wood A-Go-Go, 2 rows
- 1 x Double Shaker
- 1 x Wood Shaker Assortment 3 pcs., triangular
- 1 x Botany Shaker, Banana
- 1 x Basket





## ORIGINAL AFRICAN STYLE ROPE TUNED WOOD DJEMBES

The NINO® Original African Style Rope Tuned Wood Djembes are carved from one solid piece of plantation grown Mahogany Wood. These high quality instruments are crafted with great attention to detail and provide an outstanding sound.

| Sizes        | Diameter        | Tall    |
|--------------|-----------------|---------|
| XXS = 4 1/2" | 4 1/4" - 4 3/4" | 8"      |
| XS = 7"      | 6 1/4" - 8 1/4" | 11 3/4" |
| S = 8"       | 7" - 8 1/2"     | 15 3/4" |

| PP rope | Thickness | Runners |
|---------|-----------|---------|
| XXS     | 3 mm      | 10      |
| XS      | 3 mm      | 20      |
| S       | 4 mm      | 20      |

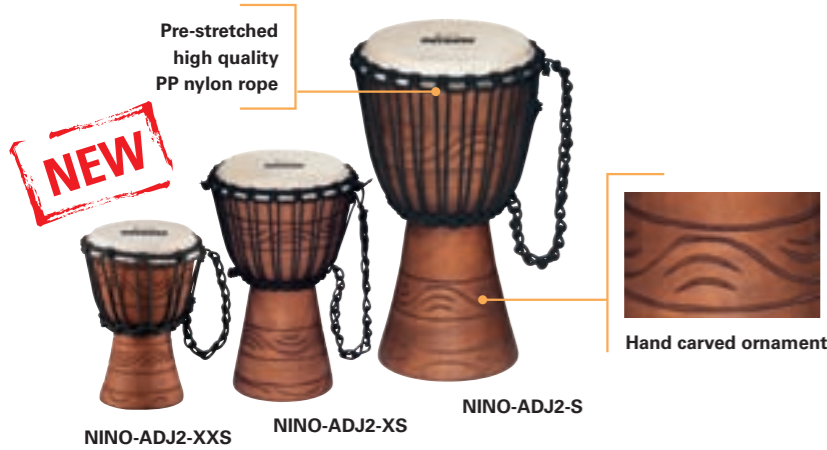

### WATER RHYTHM SERIES

**Material** Mahogany Wood  
**Features** Carved from one solid piece of plantation grown Mahogany Wood  
 Hand selected goat heads  
 High quality PP nylon ropes  
 Hand carved shells  
**Colour** Brown

### EARTH RHYTHM SERIES

**Material** Mahogany Wood  
**Features** Carved from one solid piece of plantation grown Mahogany Wood  
 Hand selected goat heads  
 High quality PP nylon ropes  
 Hand carved shells  
**Colour** Brown/Black



### MOON RHYTHM SERIES

**Material** Mahogany Wood  
**Features** Carved from one solid piece of plantation grown Mahogany Wood  
 Hand selected goat heads  
 High quality PP nylon ropes  
 Hand carved shells  
**Colour** Black

### WOOD DJEMBE

The Djembe is the most popular African drum. Even first time players are quickly able to draw different tones from this great instrument. The NINO® Wood Djembe has a diameter of 10" and a height of 21" and is the perfect drum for children in kindergarten or elementary school.



**Size** 10"  
21" tall  
**Material** Rubber Wood  
(*Hevea brasiliensis* Muell.-Arg.)  
**Features** Hand selected goat head  
 Rounded rim for playing comfort  
 Black powder coated hardware  
 Floatune Tuning System  
**Includes** Tuning key  
**Colour** NT = Natural

### NINO® DJEMBE BAG

The NINO® Djembe Bag is designed to supply reliable protection while transporting the instrument. It holds djembes up to 10" diameter.

**Size** Up to 10"  
**Material** Padded nylon  
**Features** External pocket  
 Shoulder strap  
 Carrying grip





## CAJON

The NINO® Cajon delivers the classic sound and due to its smaller dimension, it is especially suitable for a children. It is made from high quality materials ensuring long lasting life for this delightful instrument.

Not just for children, professional players may find the NINO® Cajon interesting, as they add a different yet authentic Cajon sound to their arsenal of instruments.

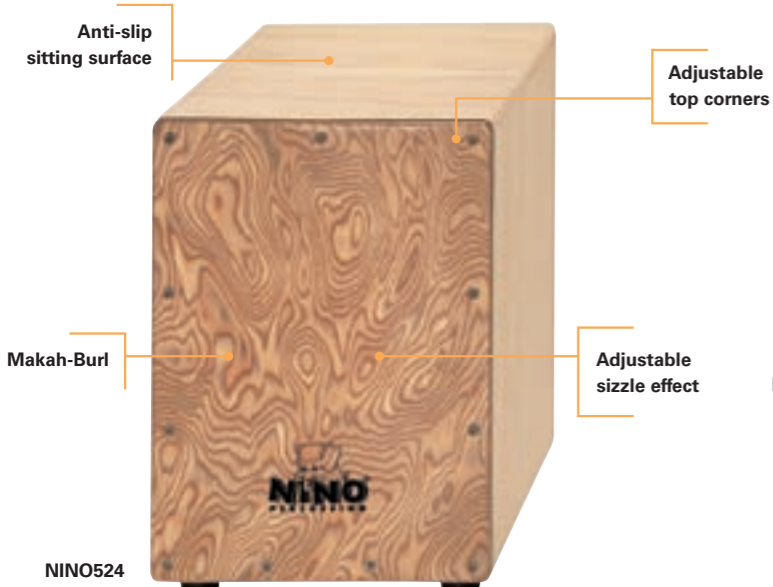

**Sizes** Length 9.5" (24 cm)  
Height 13" (33 cm)  
Depth 10" (25.4 cm)  
Weight 5.5 pds (2.500 gr)

**Materials** Frontplate: Makah-Burl  
Resonating Body: Rubber Wood (Hevea brasiliensis Muell.-Arg.)

**Features** Adjustable sizzle effect  
Anti-slip sitting surface  
Adjustable top corners

**Includes** Allen wrench

## FRAME DRUMS

These NINO® Frame Drums are traditionally equipped with buffalo skin heads and come with a wooden beater. With their warm tone they can be used in various musical occasions.



**Sizes** NINO553 = 12 1/2"  
NINO554 = 15"

**Material** Buffalo skin heads

**Feature** Velcro strap

**Includes** Wooden beater

## NINO® CAJON BAG

The NINO® Cajon Bag is designed to supply reliable protection while transporting the instrument.



**Material** Padded nylon

**Features** Padded shoulder strap  
Carrying grip

## WOOD HAND DRUMS



The NINO® Wood Hand Drums are equipped with synthetic heads that are firmly attached on a scalloped wooden frame. These nice sounding drums are light in weight and a proper instrument for children in kindergartens.

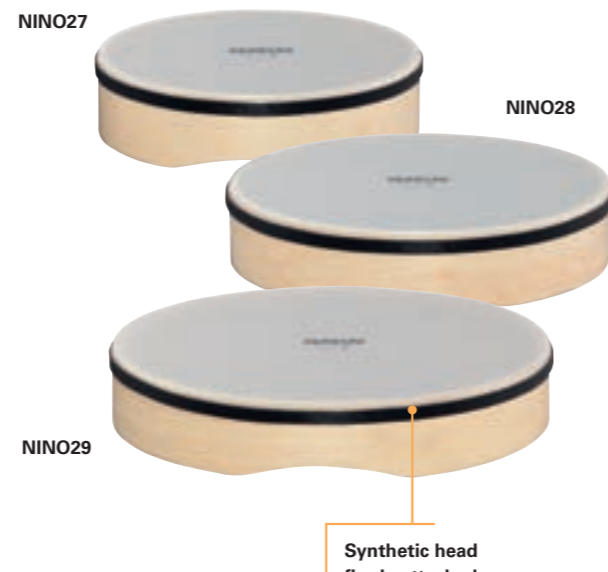

**Sizes** 10", 12", 14"

**Materials** Plastic head  
Wooden frame

## WOOD BONGOS

The NINO® Wood Bongo is an affordable yet high quality instrument with great versatility in sound. Children love the coloured Harlekin® design!



**Sizes** 6 1/2" & 7 1/2"

**Material** Rubber Wood (Hevea brasiliensis Muell.-Arg.)

**Features** Hand selected buffalo heads  
Rounded rims for playing comfort

**Includes** Tuning key

**Colours** NT-BK = Natural Shell/Black Hardware  
NT-HK = Natural Shell/Harlekin® Hardware

## ABS BONGOS PLUS

A real alternative! The NINO® ABS Bongo Plus is an affordable bongo with a great sound and functional hardware. Shells made of ABS plastic make this bongo lighter than comparable wood models.



**Sizes** 6 1/2" & 7 1/2"

**Material** ABS plastic

**Features** Hand selected buffalo heads  
Rounded rims for playing comfort  
Black powder coated hardware

**Includes** Tuning key

**Colours** BK-BK = Black Shell/Black Hardware  
R-BK = Red Shell/Black Hardware

## BONGO STAND (patented)

The patented NINO® Bongo Stand has been developed especially for kids and their height in order to offer them a safe and comfortable playing position. It can be tilted in a 90° angle and height adjusted from 31" up to 45" so children can play standing up or sitting down. The NINO® Bongo Stand is also suitable for many other common bongo models.

## NINO® BONGO BAG

The NINO® Bongo Bag is designed to supply reliable protection while transporting the instrument.



**Material** Padded nylon

**Features** Padded shoulder strap  
Carrying grip  
Reinforced bottom

The latch of the patented NINO® Bongo Stand holds the bongo absolutely stable



**Material** Chrome plated steel

**Features** Fully height adjustable from 31" to 45"  
90° angle adjustable  
Tripod stand with rubber feet  
Suitable for other common bongo models

## CAJON, FRAME DRUMS, BONGOS

CAJON, NINO® CAJON BAG, FRAME DRUMS, WOOD HAND DRUMS  
WOOD BONGOS, ABS BONGOS PLUS, NINO® BONGO BAG, BONGO STAND



## CONGA SETS

NINO® Congas are famous for their professional workmanship in fiberglass or wood sets. They all include basket stands and can therefore be played individually or in a set configuration.

### NINO89 WOOD CONGA SET

The NINO89 Wood Congas can be played standing up or sitting down and are therefore the perfect congas for children in kindergartens.

Can be played standing up due to the height



- Sizes** 8" & 9" 22" tall
- Material** Rubber Wood (*Hevea brasiliensis* Muell.-Arg.)
- Features** Hand selected buffalo heads  
Rounded rims for playing comfort  
Black powder coated hardware
- Includes** Basket stands  
Tuning key
- Colour** NT = Natural

### FIBERGLASS CONGA SET

Our fiberglass is a high quality material, manufactured by hand, into especially powerful sounding shells. The advantage over wood congas is the lower weight which makes handling much easier.

Hand selected buffalo head



- Sizes** 8" & 9" 22" tall
- Material** Premium fiberglass
- Features** Hand selected buffalo heads  
Rounded rims for playing comfort  
Black powder coated hardware
- Includes** Basket stands  
Tuning key
- Colour** HK = Harlekin®

### NINO910 WOOD CONGA SET

The NINO910 Wood Congas are ideal for first time players or schools. Height adjustable stands included.



- Sizes** 9" & 10" 28" tall
- Material** Rubber Wood (*Hevea brasiliensis* Muell.-Arg.)
- Features** Hand selected buffalo heads  
Rounded rims for playing comfort  
Black powder coated hardware
- Includes** Height adjustable basket stands with quick set up system  
Tuning key
- Colour** NT = Natural

### NINO® CONGA BAG

The NINO® Conga Bag is designed to supply reliable protection while transporting the instrument. It holds congas up to 10" diameter.



- Size** Up to 10"
- Material** Padded nylon
- Features** External pocket  
Shoulder strap  
Carrying grip





# NINO® PERCUSSION

| Model No.                                    | Size            | Height  | Material | Features | SPARE PARTS |     |     |         | Page  |     |
|--|-----------------|---------|----------|----------|-------------|-----|-----|---------|---|-----|
|  |                 |         |          |          | Head        | Rim | Lug | Bracket |   |     |
| <b>AFRICAN STYLE ROPE TUNED WOOD DJEMBES</b> |                 |         |          |          |             |     |     |         |   |     |
| NINO-ADJ2-XS                                 | 6 1/4" – 8 1/4" | 11 3/4" | •        | •        | •           | •   | •   | •       | HEAD-60   | 152 |
| NINO-ADJ2-S                                  | 7" – 8 1/2"     | 15 3/4" | •        | •        | •           | •   | •   | •       | HEAD-61   | 152 |
| <b>AFRICAN STYLE ROPE TUNED WOOD DJEMBES</b> |                 |         |          |          |             |     |     |         |   |     |
| NINO-ADJ3-XS                                 | 6 1/4" – 8 1/4" | 11 3/4" | •        | •        | •           | •   | •   | •       | HEAD-60   | 152 |
| NINO-ADJ3-S                                  | 7" – 8 1/2"     | 15 3/4" | •        | •        | •           | •   | •   | •       | HEAD-61   | 152 |
| <b>AFRICAN STYLE ROPE TUNED WOOD DJEMBES</b> |                 |         |          |          |             |     |     |         |   |     |
| NINO-ADJ4-XS                                 | 6 1/4" – 8 1/4" | 11 3/4" | •        | •        | •           | •   | •   | •       | HEAD-60   | 152 |
| NINO-ADJ4-S                                  | 7" – 8 1/2"     | 15 3/4" | •        | •        | •           | •   | •   | •       | HEAD-61   | 152 |
| <b>WOOD DJEMBE</b>                           |                 |         |          |          |             |     |     |         |   |     |
| NINO23                                       | 10"             | 21"     | •        | •        | •           | •   | •   | •       | HEAD-NINO23 RIM-NINO23 LUG-NINO23                   | 153 |
| <b>BONGOS</b>                                |                 |         |          |          |             |     |     |         |   |     |
| NINO3  | 6 1/2"          |         | •        | •        | •           | •   | •   | •       | HEAD-NINO3-65 RIM-NI3-65-BK LUG-NINO3               | 155 |
| NINO3  | 7 1/2"          |         | •        | •        | •           | •   | •   | •       | HEAD-NINO3-75 RIM-NI3-75-BK LUG-NINO3               | 155 |
| NINO3  | 6 1/2"          |         | •        | •        | •           | •   | •   | •       | HEAD-NINO3-65 RIM-NI3-65-BL LUG-NINO3               | 155 |
| NINO3  | 7 1/2"          |         | •        | •        | •           | •   | •   | •       | HEAD-NINO3-75 RIM-NI3-75-G LUG-NINO3                | 155 |
| NINO17                                       | 6 1/2"          |         | •        | •        | •           | •   | •   | •       | HEAD-NINO3-65 RIM-NI3-65-BK LUG-NINO3               | 155 |
| NINO17                                       | 7 1/2"          |         | •        | •        | •           | •   | •   | •       | HEAD-NINO3-75 RIM-NI3-75-BK LUG-NINO3               | 155 |
| <b>CONGA SETS</b>                            |                 |         |          |          |             |     |     |         |   |     |
| NINO89                                       | 8"              | 22"     | •        | •        | •           | •   | •   | •       | HEAD-NINO89-8 RIM-NINO89-8 LUG-NINO89 BRACKET-NI89  | 156 |
| NINO89                                       | 9"              | 22"     | •        | •        | •           | •   | •   | •       | HEAD-NINO89-9 RIM-NINO89-9 LUG-NINO89 BRACKET-NI89  | 156 |
| NINO910                                      | 9"              | 28"     | •        | •        | •           | •   | •   | •       | HEAD-NI910-9 RIM-NI910-9 LUG-NINO910 BRACKET-NI89   | 157 |
| NINO910                                      | 10"             | 28"     | •        | •        | •           | •   | •   | •       | HEAD-NI910-10 RIM-NI910-10 LUG-NINO910 BRACKET-NI89 | 157 |
| <b>SPARE PARTS FOR STANDS</b>                |                 |         |          |          |             |     |     |         |   |     |
| 8" Basket Stand for NINO89                   |                 |         |          |          | NISTAND-08  |     |     |         | 156   |     |
| 9" Basket Stand for NINO89                   |                 |         |          |          | NISTAND-09  |     |     |         | 156   |     |
| 9" Basket Stand for NINO910                  |                 |         |          |          | NISTAND9    |     |     |         | 157   |     |
| 10" Basket Stand for NINO910                 |                 |         |          |          | NISTAND10   |     |     |         | 157   |     |
| <b>OTHER PARTS</b>                           |                 |         |          |          |             |     |     |         |   |     |
| Lug Oil                                      |                 |         |          |          | SPARE-09    |     |     |         |   |     |
| Wood Beater                                  |                 |         |          |          | NINO9       |     |     |         |   |     |
| Triangle Beater                              |                 |         |          |          | NINO567     |     |     |         |   |     |
| Tuning Key, 13mm, chrome                     |                 |         |          |          | KEY-04      |     |     |         |   |     |



## THE SAFETY

NINO® instruments have been tested by the Landesgewerbeanstalt Bayern, Germany (LGA), Institute for the Testing of Goods and Quality Monitoring and have been awarded with the LGA Test Certificate.

This means that NINO® instruments comply with the strict requirements of the European Community Directives 88/378EC and 87/357/EC.

## PRODUCT TESTING

All NINO® instruments are regularly tested for safety and sanitary harmlessness according to the EC Directives 88/378/EC (Toy Safety Directive) and 87/357/EC (Limitation of Food).

The tests are carried out by the Landesgewerbeanstalt Bayern, Germany (LGA), a modern testing and consulting services organization with over 30 branches worldwide.

As a recognized institute for the testing of goods and quality monitoring, the LGA is entitled to award the GS and LGA test marks which are accepted throughout Europe and internationally as a guarantee of safety.



## NINO® INSTRUMENTS PASS THE FOLLOWING TESTS

|   |
|---|
| Testing in dependence on the Toy Safety Directive (88/378/EC) |
| Mechanical and physical characteristics                       |
| Inflammability  |
| Migration of certain parts                                    |
| Saliva and perspiration resistance                            |
| Colorfastness   |
| Determination of the content of Pentachlorophenol (PCP)       |
| Testing with regard to pesticides                             |
| Valuation in accordance with EC Directive 87/357/EC           |



## CERTIFICATION

After passing all tests, the internationally accepted LGA Test Certificate was awarded for all NINO® percussion instruments. This certificate vouches for quality and safety.

## MATERIAL & ECOLOGY

Wood is a raw material which is present in almost every part of our daily life. Trees are an important part of the complex eco-system while healthy forests are imperative for the Earth's atmosphere.

Only Rubber Wood (*Hevea brasiliensis* Muell.-Arg.) is used for the making of NINO® percussion instruments. This wood fulfils the CITES regulations ("Convention on International Trade in Endangered Species of Wild Fauna and Flora") and originates from environmentally controlled forests from industrial wood plantations.

## WOOD FROM ENVIRONMENTALLY CONTROLLED WOOD PLANTATION

Thailand is a logical manufacturing base for percussion instruments due to the fact that the *Hevea Brasiliensis*, which was indigenous to Brazil and later transported by way England to Asia, has been commercially grown in Southeast Asia during the last century on plantation farms for the production of Latex.

The traditional plantation of Rubber Wood (*Hevea brasiliensis* Muell.-Arg.) meets all ecological requirements. In a natural evolution, new trees are planted and the older ones, which have ceased to provide latex, are harvested. In this way, plenty of raw material is available and the valuable rain forest eco-system is preserved.

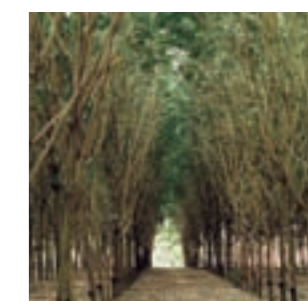

Rubber Wood plantation farm in Thailand



## MEINL MERCHANDISE

Support your favourite percussion brand with the official MEINL swag. A selection of exclusive items made from the highest quality materials.

### LANYARD



M35

### LONG SLEEVE W. RED ARMS

**Sizes** M, L, XL  
**Colour** Black/Red  
**Front** MEINL logo, small  
**Back** MEINL logo, big



M74

Front

Back

### TRAINING JACKET

**Sizes** M, L, XL, XXL  
**Colour** Black  
**Front** MEINL logo, small  
**Back** MEINL logo, big



M73

Front

Back

### SWEAT SHIRT

**Sizes** S, M, L, XL, XXL  
**Colour** Black  
**Front** MEINL logo, small  
**Back** MEINL logo, big



M49

Front

Back

### MOUSE PAD "CONGA HEAD"

M51



### POLO SHIRT

**Sizes** M, L, XL, XXL  
**Colour** Black  
**Front** MEINL logo, small



M25

Front only

### HOOD SHIRT W. ZIPPER

**Sizes** S, M, L, XL, XXL  
**Colour** Black  
**Front** MEINL logo, small  
**Back** MEINL logo, big



M48

Front

Back

### T-SHIRT

**Sizes** S, M, L, XL, XXL  
**Colour** Black  
**Front** MEINL logo, small  
**Back** MEINL logo, big



M42

Front

Back

## UPLOAD & WIN

Shoot a short film playing your MEINL instrument and get the chance to win a PRIZE!

Every month we'll start a new video contest for the MEINL percussion community. We'll focus on a different product category on the site each month. Every video related to the "highlighted category" will be part of the contest.

NOTE:

Everyone who joins the MEINL percussion community can rate the video clips. This is how we will select the best video. The winner will be contacted by an official MEINL percussion team member and you can be mentioned in the MEINL percussion blog.

[meinlpercussion.com](http://meinlpercussion.com)



Take a closer look at MEINL percussion. Get uncensored and unedited news. See the philosophy. Share your thoughts and impressions. Come to our "Blogs". Stay tuned, get involved, and have fun!

For more information about MEINL percussion products, endorsing artists, tips'n tricks around percussion, exclusive video footage and mp3 downloads, please log on to [meinlpercussion.com](http://meinlpercussion.com) and become a member of our world wide community.

### IMPRESSUM

All features are subject to change without notice. Not responsible for typographic errors. No part of this book may be reprinted, reproduced or included in any online service in any form in whole or in part, without the prior written permission of MEINL.  
 © 2008 Roland Meinl Musikinstrumente GmbH & Co. KG

**Advertising Concept & Design by:**  
 infowerk ag

**Content & Direction by:**  
 Udo Heubeck, Mario Schmitt

**Photos by:**  
 Studio Waldeck, Markus Buberl, Mario Schmitt, Alex Solca, Rick Malkin, Biggi Sauer, Rob Shanahan, Scott Saltzmann, Manfred Pollert, Sean Vennet, James Cumpsty and Andrea Meister.

**MEINL would like to thank:**  
 Jan Heinemann, [www.keksbox.com](http://www.keksbox.com)  
 Markus Buberl, [www.triebwerk.net](http://www.triebwerk.net)

**MEINL GLOBAL HEADQUARTER**  
 Am Bahnhof 2  
 91468 Gutenstetten  
 GERMANY

**MEINL USA L.C.**  
 3300 Ambrose Avenue  
 Nashville, TN 37207  
 USA

Printed in Germany M-CA301207



[meinpercussion.com](http://meinpercussion.com)

