



2009  
The MEINL Book of  
Percussion

Featuring Faces of Percussion



# Faces of Percussion

With our Faces of Percussion contest on Facebook, we ended up connecting with a large number of people who have a passion for percussion. Our belief that the expression of one's self through music is an extension of one's personality turned out to be correct. Similar to a person's heartbeat, which is always individual, we found unique expressions of emotion in your pictures. This impression made us very happy and inspired us to create this catalogue as an appreciation of your love for rhythm.

rhythm  
 expression  
 passion  
 personality  
 impression  
 emotion  
 heartbeat  
 individual  
 extension

Jonas Seiferlein

Steve

Judith Rößiger

Nurmi Valtteri

Sven Eisenmann

Angela

## DIRECTORY

PRODUCT GROUP	PAGE
Congas	7
Bongos	32
Cajons	44
Djembes	62
Samba	76
Timbales	88
Frame Drums	94
Tambourines	100
Steelbells	106
Chimes	110
Shakers	114
Maracas	118
Guiros	119
Cabaras	120
Ritual Drums	122
Claves	127
Ibo Drums	128
Dancing Drums	130
Doumbeks	132
Darbukas	134
Hardware	136
Candela Cymbals	140
Gear	142
Nino®	144
Merchandise	172



# It's our world - we care for it !!!

Actions speak louder than words! This is why we take our responsibility seriously and commit ourselves to several environmental projects.

Our specially developed vacuum distillation saves 90,000 liters of drinking water, the world's most threatened resource.

In order to minimize our electricity usage, all of our buildings are equipped with motion sensors and our centralized electricity controls prevents the waste of this resource.

With our solar-power-plant (Photovoltaic-System) we produce enough power to cover one-third of our annual demand or to supply 16 houses with electricity.

All of the electricity used in our facility is produced from renewable energies. Thus we reduced our carbon monoxide emission from 200 tons per year down to zero.

Reusable materials like paper, plastic or styrofoam are too precious to be wasted. We separate them for efficient recycling.

We are a member of the German working group of the Forest Stewardship Council (FSC)



## WOOD FROM ENVIRONMENTALLY CONTROLLED WOOD PLANTATION

Thailand is a logical manufacturing base for percussion instruments due to the fact that the *Hevea Brasiliensis*, which was indigenous to Brazil and later transported by way England to Asia, has been commercially grown in Southeast Asia during the last century on plantation farms for the production of Latex.

The traditional plantation of Rubber Wood (*Hevea brasiliensis* Muell.-Arg.) meets all ecological requirements. In a natural evolution, new trees are planted and the older ones, which have ceased to provide latex, are harvested. In this way, plenty of raw material is available and the valuable rain forest eco-system is preserved.



Rubber Wood plantation farm in Thailand

# In Memoriam Roland Meinel

Roland Meinel, founder of Roland Meinel Musikinstrumente, a pioneer in the art of cymbal and percussion manufacturing, known and appreciated as an outstanding businessman, passed away on December 04, 2007 at the age of 78.

Roland Meinel was born on March 04, 1929 in Silberbach, Sudetenland, as the oldest child of Emil and Hedwig Meinel. After attending elementary and business school, Roland served in the military at the age of 16 during the last days of World War II. After his military service, Roland began an apprenticeship as a wind instrument maker in Grasslitz, which was interrupted because of his family's relocation to a small city named Rimpar near Würzburg after the war.

There he began a business apprenticeship, which upon completion his family moved to Neustadt a. d. Aisch where he founded the Roland Meinel Musikinstrumente company in 1951. That is when he began to produce Meinel cymbals. In 1964 the company's first employee was hired and in 1969 a new company building was constructed. During the 70's, Roland built up and developed the cymbal production, while at the same time establishing the company's distribution business, becoming a strong wholesale partner for music retailers in Germany and Austria. In 1978 he founded Meinel's first percussion factory in Thailand and began introducing the full range of Meinel percussion instruments. Many groundbreaking innovations in the cymbal and percussion world, which are still applied to this day, were invented by Roland Meinel. His relentless and hard work laid the foundation for his company's current success as one of the world's leading manufacturers and distributors of musical instruments.

After his son Reinhold began working with the company in 1972, Roland continued to be involved in all of the company's operations. As long as he lived, his presence, sense of humor, and magnanimity were always felt among all Meinel's employees, who as a result always held him in high esteem. His life's story is inseparably connected with the success of his company.



*Roland Meinel*



# Headliner® Series Congas

## 10" & 11" WOOD CONGA SETS

The 10" & 11" pair is the perfect set of congas to get you started. The compact size is easy for young players to handle, light to carry, and has a full, rich sound. You can develop a full foundation of conga techniques and rhythms with these student-friendly drums.



- Sizes 10" & 11" Conga Set  
28" tall
- Material Rubber Wood  
(*Hevea brasiliensis* Muell.-Arg.)
- Features Hand selected buffalo heads  
8 mm strong tuning lugs  
Original MEINL style tuning brackets  
2 mm rounded rims  
Black powder coated hardware
- Includes Height adjustable basket stands  
with quick set up system  
Tuning key
- Colours BK = Black  
NT = Natural  
VSB = Vintage Sunburst  
WRB = Wine Red Burst
- Finish High gloss



# Headliner® Series Congas

## 11" & 12" WOOD CONGA SETS

The 11" & 12" pair is a full-sized entry level conga set. They have superb projection, warm tones, light weight and features found on professional congas. They offer outstanding quality and great value in the budget price range. This is a pair of congas you will want to keep around as you develop your skills.



- Sizes 11" & 12" Conga Set  
28" tall
- Material Rubber Wood  
(*Hevea brasiliensis* Muell.-Arg.)
- Features Hand selected buffalo heads  
8 mm strong tuning lugs  
Original MEINL style tuning brackets  
2 mm rounded rims  
Black powder coated hardware
- Includes Height adjustable basket stands  
with quick set up system  
Tuning key
- Colours MA = Maple  
NT = Natural  
PW = Pearl White  
VSB = Vintage Sunburst  
WRB = Wine Red Burst
- Finish High gloss



# Headliner® Designer Series Congas **NEW!**

The new MEINL Headliner® Designer Series Congas are offered individually, and you can make up a trio of the three singles, nino, quinto and conga. These three sizes create a full tonal range. Headliner® Designer Series Congas are available in two exciting finishes.

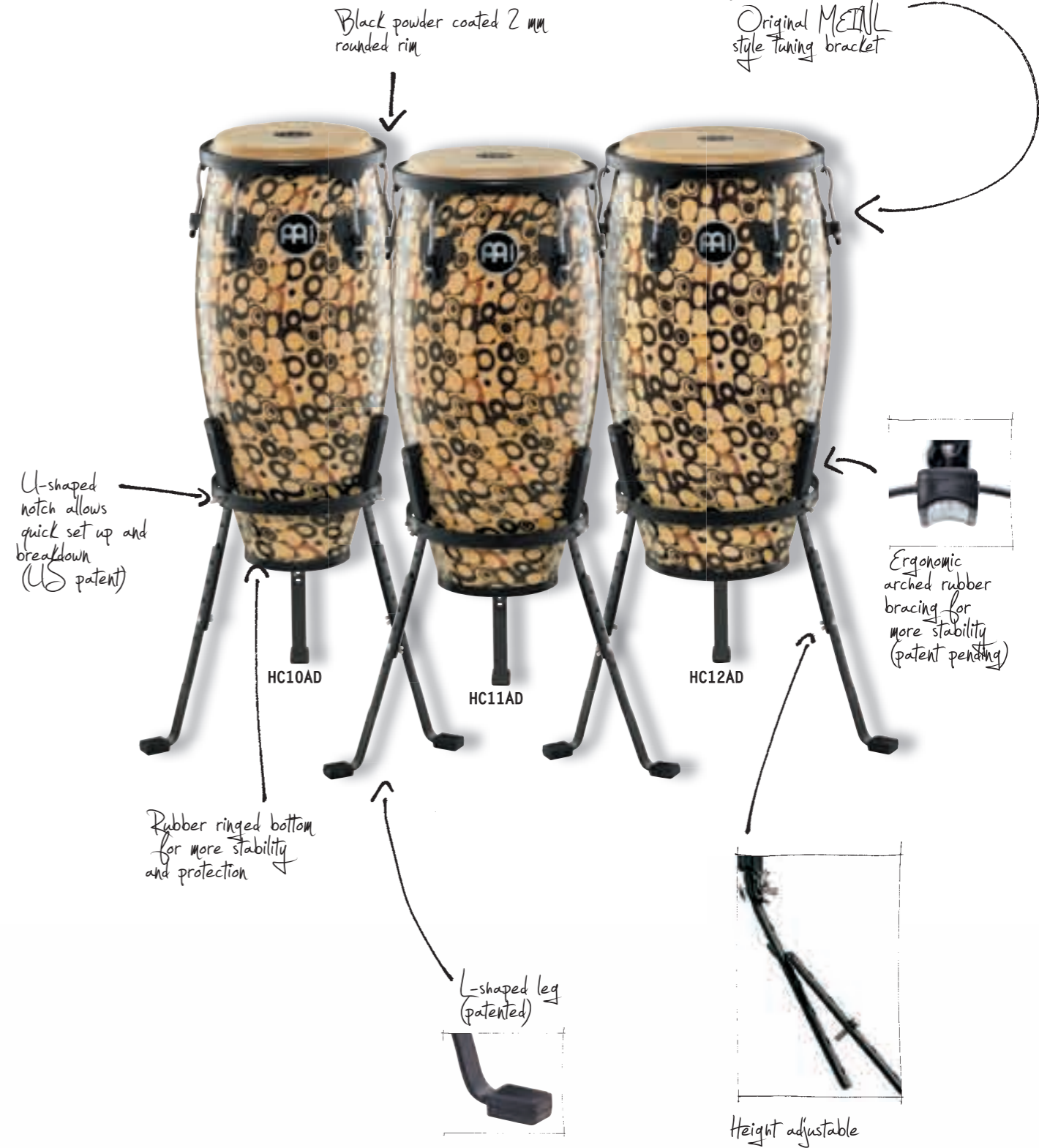
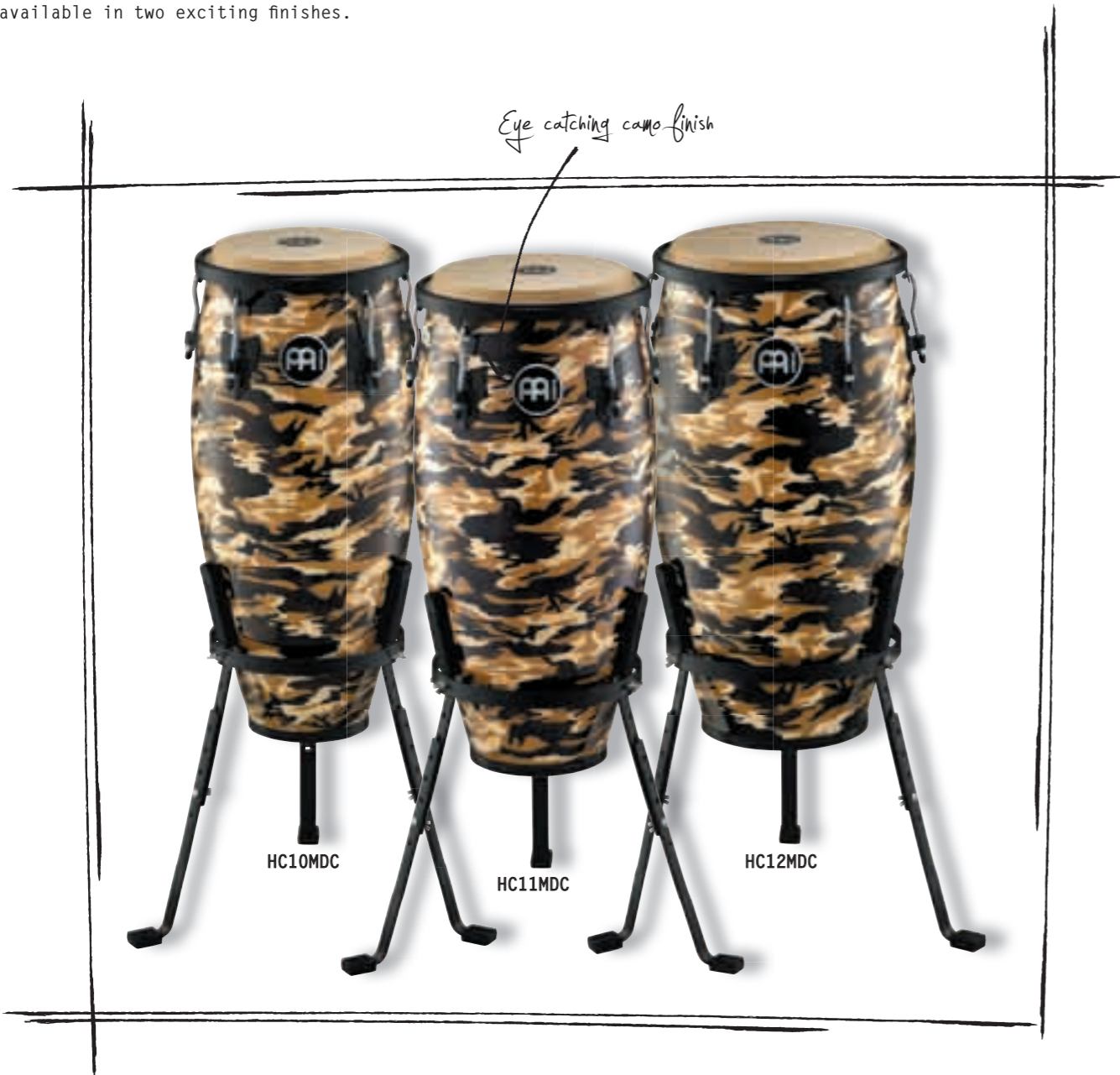

- Sizes 10" Nino, 11" Quinto, 12" Conga 28" tall
- Material Cloth-covered Rubber Wood (*Hevea brasiliensis* Muell.-Arg.)
- Features Hand selected buffalo heads  
8 mm strong tuning lugs  
Original MEINL style tuning brackets  
2 mm rounded rims  
Black powder coated hardware
- Includes Height adjustable basket stands with quick set up system  
Tuning key
- Colours AD = Art Deco  
MDC = Midnight Desert Camo
- Finish High gloss

Cindy

Manuel Rondriges

Amely White

Bill

Adriane





# Marathon® Classic Series Congas

The MEINL Marathon® Classic Series Congas set the standard in this price range by which other wood congas are judged. They combine professional features at a very attractive price.



MCC11SNT-M

MCC1134SNT-M

MCC1212SNT-M



Black powder coated 2.6 mm rounded SSR-Rim

Ergonomic arched rubber bracing for more stability (patent pending)



- Sizes 11" Quinto, 11 3/4" Conga, 12 1/2" Tumba, 30" tall
- Material Two ply Rubber Wood (Hevea brasiliensis Muell.-Arg.)
- Features True Skin Buffalo Heads, 8 mm strong tuning lugs, 2.6 mm rounded SSR-Rims, Black powder coated hardware
- Includes Steely II Conga Stand (patented), MEINL Conga Saver (patented), Accessory pouch, L-shaped tuning key, Tune Up Oil
- Colours CB = Coffee Burst, high gloss, SNT-M = Super Natural, matte

\*in United States, China, Thailand



MCC11CB

MCC1134CB

MCC1212CB

# Marathon® Designer Series Congas

This designer series comes in a stunning Leopard Burl finish in high gloss, has professional features and is available at a very attractive price.



Black powder coated 2.6 mm rounded SSR-Rim



MCC11LB

MCC1134LB

MCC1212LB



- Sizes 11" Quinto, 11 3/4" Conga, 12 1/2" Tumba, 30" tall
- Material Two ply Rubber Wood (Hevea brasiliensis Muell.-Arg.)
- Features True Skin Buffalo Heads, 8 mm strong tuning lugs, 2.6 mm rounded SSR-Rims, Black powder coated hardware
- Includes Steely II Conga Stand (patented), MEINL Conga Saver (patented), Accessory pouch, L-shaped tuning key, Tune Up Oil
- Colour LB = Leopard Burl
- Finish High gloss

Ergonomic arched rubber bracing for more stability (patent pending)



Ellen Mayer, Germany

# Marathon® Designer Series Congas NEW!

The new MEINL Marathon Designer Series Congas take the look and style to new places! Our snappy appliqué graphics set new standards in the industry.



- Sizes 11" Quinto, 11 3/4" Conga, 12 1/2" Tumba 30" tall
- Material Rubber Wood with appliqué graphics (*Hevea brasiliensis* Muell.-Arg.)
- Features True Skin Buffalo Heads 8 mm strong tuning lugs 2.6 mm rounded SSR-Rims Black powder coated hardware
- Includes Steely II Conga Stand (patented) MEINL Conga Saver (patented) Accessory pouch L-shaped tuning key Tune Up Oil
- Colours IS = Island Sunset VR = Vintage Racer
- Finish High gloss

\*in United States, China, Thailand



# Marathon® Designer Series Congas NEW!

The new MEINL Marathon® Designer Series Congas take the look and style to new places! Our snappy appliqué graphics will set new standards in the industry.



- Sizes 11" Quinto, 11 3/4" Conga, 12 1/2" Tumba  
30" tall
- Material Rubber Wood with appliqué graphics (*Hevea brasiliensis* Muell.-Arg.)
- Features True Skin Buffalo Heads  
8 mm strong tuning lugs  
2.6 mm rounded SSR-Rims  
Black powder coated hardware
- Includes Steely II Conga Stand (patented)  
MEINL Conga Saver (patented)  
Accessory pouch  
L-shaped tuning key  
Tune Up Oil
- Colours CAN = Calypso Night  
MS = Mega Star
- Finish High gloss



\*in United States, China, Thailand

# Artist Series Congas

All of Luis' needs have been met and exceeded with the MEINL Artist Series Luis Conte Signature Congas. They combine the charm and sound of the old traditional Cuban drums with modern features and innovations. These congas are equipped with traditional rims, are mounted as close to the shell as possible, and when combined with MEINL's True Skin Buffalo Heads, they enable an even more controlled sound.



Black powder coated  
4 mm traditional TTR-Rim

*Luis Conte*



LC11NT-M

LC1212NT-M

LC1134NT-M

Rubber ringed bottom for more stability and protection



The Meinl Artist Series Congas (Luis Conte) won the MIPA Award in the Best Percussion Product category.

**Sizes** 11" Quinto, 11 3/4" Conga, 12 1/2" Tumba, 30" tall  
**Material** Two ply Rubber Wood (Hevea brasiliensis Muell.-Arg.)  
**Features** True Skin Buffalo Heads, 8 mm strong tuning lugs, 4 mm traditional TTR-Rims, Black powder coated hardware

**Includes** MEINL Conga Saver (patented), MEINL Soundpads, Accessory pouch, L-shaped tuning key, Tune Up Oil  
**Colour** NT-M = Natural  
**Finish** Matte

\*in United States, China, Thailand



*Luis Conte, USA*

In 2008 I have spent time in the studios, recording albums with James Taylor, Leona Lewis, Glenn Campbell, Cheap Trick, The Chealsey Smiles, Lenka, Dave Koz, Chaka Khan, Pussy Cat Dolls, Rick Springfield, Donovan Frankenreiter, Gavin Degraw, Bernie Williams, Greg Karukas, Hope, Marco Antonio Solis, and many more..... worked on motion pictures such as Hancock, Sex in the City, House on the Left, and more..... performed on the Oscars with Christen Chenowith and Marlon Saunders and as a clinician at the Heartbeat for Worship convention in North Carolina .....toured with James Taylor on the 2008 "Band of Legends Tour" this summer, to be continued into 2009.....a member of the orchestra at the number one tv show in the USA, "Dancing with the Stars" now on it's seventh season..... filming for the Drum Channel with drummer Alex Gonzalez from Mana.....continued to promote my new cd Marimula around the LA and Ventura Counties.....voted "Percussionist of the Year" by the readers of Drum magazine.....

*Luis Conte*

# Professional Series Congas

The Roland Meinl Professional Series Congas - one of the finest instruments in the MEINL Percussion program and the preferred conga model by many top congueros. Outstanding in look and sound, they reach from fat basses to cutting slaps with a great warm overall tone. They set the standard in the professional conga ranges.



CSR Safe & Sound-Rim  
Chrome plated 4 mm rounded SSR-Rim



The Meinl Professional Series Congas won the MIPA Award in the Best Percussion Product category.



- Sizes 11" Quinto, 11 3/4" Conga, 12 1/2" Tumba, 30" tall
- Material Two ply Rubber Wood (Hevea brasiliensis Muell.-Arg.)
- Features True Skin Buffalo Heads, 10 mm strong tuning lugs, 4 mm rounded SSR-Rims, Chrome plated hardware
- Includes MEINL Conga Saver (patented), MEINL Soundpads, Accessory pouch, L-shaped tuning key, Tune Up Oil
- Colours ARF = Aztec Red Fade, BB = Brown Burl, NT = Natural
- Finish High gloss



\*in United States, China, Thailand

# Fibercraft Series Congas

MEINL Fibercraft Congas offer great quality, durability, volume, and they are resistant to climatic changes. They have a great presence and brilliance in sound. Great for live playing and extensive road use.

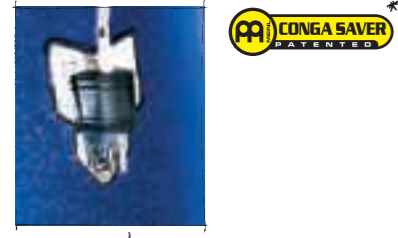

**CONGA SAVER**  
PATENTED

Extraordinary sparkling effect



FC11BSP

FC1134BSP

FC1212BSP



FC11RSP

FC1134RSP

FC1212RSP



FC11BKSP

FC1134BKSP

FC1212BKSP

Chrome plated 4 mm rounded SSR-Rim  
**SSR** MEINL  
Safe & Sound-Rim

\*in United States, China, Thailand



Fenne Krone,  
Netherlands

- Sizes 11" Quinto, 11 3/4" Conga, 12 1/2" Tumba, 30" tall
- Material Premium fiberglass
- Features True Skin Buffalo Heads, 10 mm strong tuning lugs, 4 mm rounded SSR-Rims, Chrome plated hardware
- Includes MEINL Conga Saver (patented), MEINL Soundpads, Accessory pouch, L-shaped tuning key, Tune Up Oil
- Colours BKSP = Black Sparkle, BSP = Blue Sparkle, RSP = Red Sparkle

Berenice Vieira Kersting

Jimmy

Rondriges Estevan

Felix Bucka

Tanja + Friend



# Fibercraft Designer Series Congas NEW!

The new MEINL Fibercraft Designer Series Congas come in a dazzling new carbon finish. These congas are made from premium fiberglass for dependability and great sound characteristics.

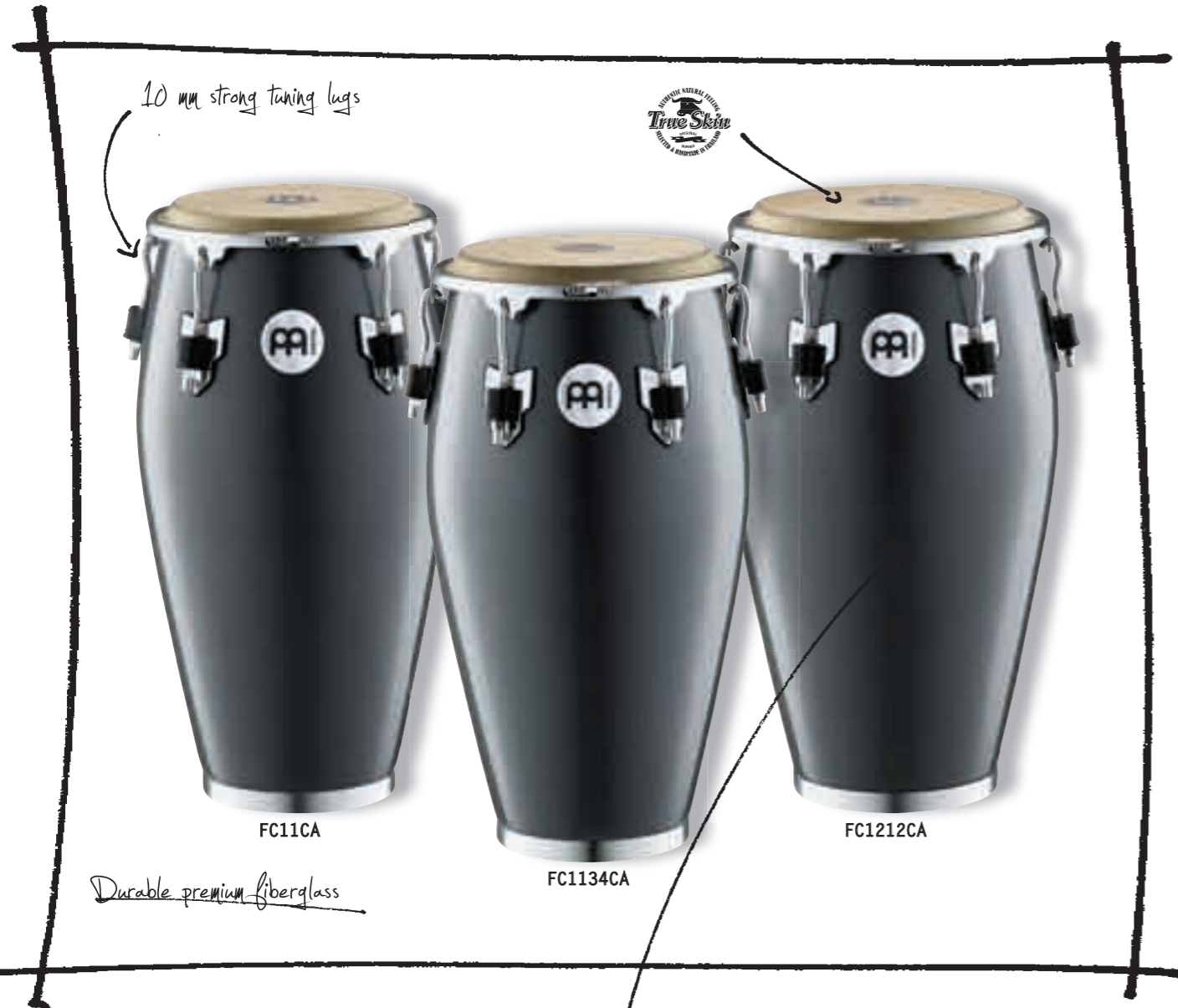

Crisp and clean carbon finish

- Sizes 11" Quinto, 11 3/4" Conga, 12 1/2" Tumba, 30" tall
- Material Premium fiberglass
- Features True Skin Buffalo Heads, 10 mm strong tuning lugs, 4 mm rounded SSR-Rims, Chrome plated hardware
- Includes MEINL Conga Saver (patented), MEINL Soundpads, Accessory pouch, L-shaped tuning key, Tune Up Oil
- Colour CA = Carbon finish

# Floatune Series Congas

The MEINL Floatune Tuning System is a true and unique MEINL innovation. All mounting hardware is completely isolated from the shell. This avoids the need to drill through the shell and mount hardware with bolts, which reduces the resonant vibrations of the shell. The Floatune Tuning System tunes up just like lug-equipped congas, only with an improved sound.



- Sizes 10" Nino, 11" Quinto, 12" Conga, 13" Tumba, 30" tall
- Material Two ply Rubber Wood (Hevea brasiliensis Muell.-Arg.)
- Features Floatune Tuning System, True Skin Buffalo Heads, 10mm strong tuning lugs, 4mm rounded SSR-Rims, Chrome plated hardware
- Includes MEINL Conga Saver (patented), MEINL Soundpads, Accessory pouch, L-shaped tuning key, Tune Up Oil
- Colour BB = Brown Burl
- Finish High gloss



Brian Rosenworcel, USA

\*in United States, China, Thailand

# Artist Series Congas

Ramon "Mongo" Santamaria was without a doubt one of the most respected conga players ever, and a pioneer of modern Latin Jazz. During the 50's his band "Black Cuban Diamonds" laid down the foundation for an outstanding career. Ramon recorded dozens of legendary percussion albums. Worldwide Jazz hits, such as "Watermelon Man" in 1963 and the album "Summertime" from 1980 are only two of the many recordings from this great master percussionist. Mongo has inspired more percussionists around the globe than any other conguero. Mongo Santamaria died at the Baptist Hospital in Miami, USA in February 2003. He was 85 years old. It is with great appreciation and deepest respect that we honour our friend and his life's work with his MEINL Artist Series Mongo Santamaria Congas.



Ramon "Mongo" Santamaria, Cuba

- Sizes 11" Quinto, 11 3/4" Conga, 12 1/2" Tumba, 30" tall
- Material Two ply American White Ash (*Fraxinus americana* L.)
- Features True Skin Buffalo Heads, 10 mm strong tuning lugs, 4 mm rounded SSR-Rims, Gold tone hardware
- Includes MEINL Conga Saver (patented), MEINL Soundpads, Accessory pouch, L-shaped tuning key, Tune Up Oil
- Colour AWA = American White Ash
- Finish High gloss



Mongo Santamaria

MSA11AWA

MSA1134AWA

MSA1212AWA

Two ply American White Ash

\*in United States, China, Thailand



Gold tone 4 mm rounded SSR-Rim



# Woodcraft Series Congas

The MEINL Woodcraft Series Congas stand for tradition combined with exceptional workmanship. Only the finest hand selected materials are used to produce these premium drums. Their "Cuban Style" shells provide a broad range of different tonal characteristics.



WC112ZFA-M

WC1134ZFA-M

WC1212ZFA-M

Traditional, "Cuban Style" shell for enhanced volume

Two ply American White Ash

- Sizes 11" Quinto, 11 3/4" Conga, 12 1/2" Tumba, 30" tall
- Material Two ply American White Ash (*Fraxinus americana* L.)
- Features True Skin Buffalo Heads, 10 mm strong tuning lugs, 4 mm traditional TTR-Rims, Chrome plated hardware
- Includes MEINL Conga Saver (patented), MEINL Soundpads, Accessory pouch, L-shaped tuning key, Tune Up Oil
- Colour ZFA-M = Zebra Finished Ash
- Finish Matte



Paul Brown

Christina Bartels

Nurmi Valterri

Hanna Gensheimer

Alexander Greims

Congas

ARTIST SERIES CONGAS (Mongo Santamaria) WOODCRAFT SERIES CONGAS



# Stands & Bags

## 1. STEELY II CONGA STANDS (patented)

The MEINL Steely II Conga Stands (patented) are available for all MEINL Professional Series Congas.

**MODELS:**  
 For Marathon® Classic Series  
 For Luis Conte Artist Series  
 ST-MCC11BK 11"  
 ST-MCC1134BK 11 3/4"  
 ST-MCC1212BK 12 1/2"  
 Black powder coated

For Floatune Series  
 ST-FL10CH 10"  
 ST-FL11CH 11"  
 ST-FL12CH 12"  
 ST-FL13CH 13"  
 Chrome plated

For Professional Series  
 For Fibercraft Series  
 ST-MP11CH 11"  
 ST-MP1134CH 11 3/4"  
 ST-MP1212CH 12 1/2"  
 Chrome plated

For Mongo Santamaria Artist Series  
 ST-MSA11G 11"  
 ST-MSA1134G 11 3/4"  
 ST-MSA1212G 12 1/2"  
 Gold tone

For Woodcraft Series  
 ST-WC11CH 11"  
 ST-WC1134CH 11 3/4"  
 ST-WC1212CH 12 1/2"  
 Chrome plated

## 2. STEELY II CONGA STAND HEIGHT EXPANDER SETS (patent pending)

These innovative add-ons to the MEINL Steely II Conga Stands (patented) allow an easy and effective height extension, which provides a more comfortable playing position for taller congueros.

Ergonomic arched rubber bracing for more stability (patent pending)

U-shaped notch allows quick set up and breakdown (US patent)



L-shaped leg and metal spike attachment (patented)

Quick and easy height adjustability (patent pending)

**Material** Steel  
**Features** Metal spike attachment on each leg  
 L-shaped legs  
 U-shaped notch for quick set up and breakdown  
 Notches for quick height adjustability  
**Includes** Allen wrench

Easy and effective height extension



**Material** Steel  
**Feature** Easy and effective height extension  
**Includes** Mounting screws  
 Allen wrench  
**Finishes** Black powder coated  
 Chrome plated  
 Gold tone

Compatible for all sizes



The lightweight stand can be folded to a compact unit which requires little space

**Material** Chrome plated steel  
**Features** Unique design  
 Rubber padded crossbeams  
 Fully height adjustable  
 Folds up to a compact unit  
**Includes** Allen wrench  
 Memory locks

## 4. PROFESSIONAL CONGA BAGS

The MEINL Conga Bags come in three sizes: Quinto, Conga, and Tumba. An extra top zipper simplifies packing and unpacking of your drum. Additional features are padded backpack straps and an external pocket for accessories.



Additional upright zipper



## 5. CONGA SOUND PLATE

The new MEINL Conga Sound Plate is a sturdy wooden disc that provides a hard, sound reflective surface under your conga. This is ideal for extra projection, especially when playing on soft surfaces such as a carpet.

**Sizes** 11"  
 11 3/4"  
 12 1/2"  
**Material** Heavy duty padded nylon  
**Features** Additional upright zipper  
 External pocket  
 Padded backpack straps  
 Carrying grip

Carrying grip

Padded backpack strap

Fits under any conga!

**Material** Rubber Wood  
 (Hevea brasiliensis Muell.-Arg.)  
**Size** 13 1/4"



NEW!

# Bongos

Percussion is in my heart, and  
bongo playing is my passion

I live in Caracas, Venezuela and I have been involved with music for about 20 years. As a session drummer I have recorded more than 20 albums with renowned artists from the most diverse genres and styles, besides participating in musical projects for TV commercials, movies and soap-operas.

## The Bongo Project.

The whole idea of this project consists in playing with the bongo certain themes that lack any kind of percussion in their original versions. This forces me to play in musical schemes that are quite strange and new for the bongo. Obviously, I avoided selecting themes that had a Latin sound and really thrived for more adventurous and challenging stuff. Of course, the project's main trait is to show the World a unique vision of the bongo and its unlimited possibilities. This way, I have recorded themes from Rimsky Korsakov, Barriere, Bobby McFerrin, Yo-Yo Ma, Andy McKee, Don Ross and ventured into the world of tango and milonga, joropo, golpe and other traditional genres. Public reaction to these musical pieces had been so wonderful that I have decided to continue the search of new challenges and musical horizons for the bongo.

In June 2008 I found Meinl Percussion's awesome web page and I read about a contest hosted by the site. I was surprised to find out that it was for bongo videos (a lucky coincidence!). I seized the opportunity and uploaded some of my jobs on the Bongo Project. So it happened that the company offered me their endorsement.

My dream is to take this project beyond physical and musical frontiers. The sky is the limit...and every step to new heights is marked with the beat of a drum.

[www.lerryys.com](http://www.lerryys.com)



# Headliner® Series Bongos

## 1. HEADLINER® SERIES ABS BONGO

The new MEINL Headliner® Series ABS Bongo has the features of traditional bongos, made from sturdy ABS plastic. The compact size makes them handy and portable.



**Sizes** 6 1/2" Macho & 7 1/2" Hembra  
**Material** ABS plastic  
**Features** Hand selected buffalo heads  
 Rounded rims for playing comfort  
 Black powder coated hardware  
**Includes** Tuning key  
**Colour** BK = Black

## 2. HEADLINER® SERIES ACRYLIC BONGO

The new MEINL Headliner® Series Acrylic Bongo has a great look. The crystal clear acrylic shells add a touch of transparency and lightness. The shells are joined together in the traditional style.



**Sizes** 6 1/2" Macho & 7 1/2" Hembra  
**Material** Acrylic  
**Features** Hand selected buffalo heads  
 Rounded rims for playing comfort  
 Black powder coated hardware  
**Includes** Tuning key  
**Finish** Transparent

## 3. HEADLINER® SERIES WOOD BONGOS

MEINL Headliner® Series Bongos are perfect for the student or hobbyist who is looking for a high quality instrument right from the beginning.



**Sizes** 6 3/4" Macho & 8" Hembra  
**Material** Cloth-covered Rubber Wood (Hevea brasiliensis Muell.-Arg.)  
**Features** Hand selected buffalo heads  
 Rounded rims for playing comfort  
 Black powder coated hardware  
**Includes** Tuning key  
**Colours** AD = Art Deco  
 MDC = Midnight Desert Camo  
**Finish** High gloss

Stylish Art Deco finish

## 4. HEADLINER® DESIGNER SERIES BONGOS

The new MEINL Headliner® Designer Series Bongos offer two exciting finishes. The construction is in the traditional style, with a solid woodblock connection.

## 5. BONGO BAG

The MEINL standard Bongo Bag offers dependable protection at an affordable price making transportation as hassle free as possible.

## 5.



**Size** Bongos up to 7 1/2" Macho & 8 1/2" Hembra  
**Material** Heavy duty padded nylon  
**Features** Padded shoulder strap  
 Carrying grip



Bertil Mark, Germany



**Sizes** 6 3/4" Macho & 8" Hembra  
**Material** Rubber Wood (Hevea brasiliensis Muell.-Arg.)  
**Features** Hand selected buffalo heads  
 8 mm strong tuning lugs  
 2 mm rounded rims  
 Black powder coated hardware  
 Interior backing plates  
**Includes** Tuning key  
**Colours** MA = Maple  
 NT = Natural  
 PW = Pearl White  
 VSB = Vintage Sunburst  
 WRB = Wine Red Burst  
**Finish** High gloss

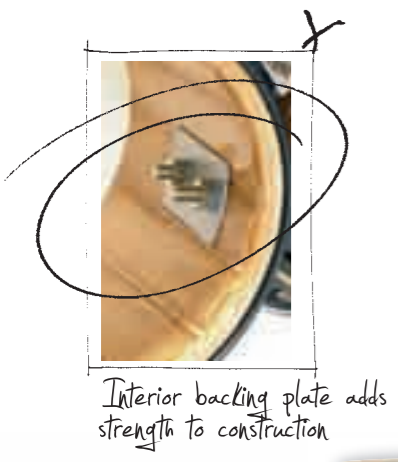

Nurmi Valtteri Tom Bailey

# Free Ride Series Wood Bongos

## 1. FREE RIDE DESIGNER SERIES WOOD BONGO (patented in Germany)

The Free Ride Designer Series Wood Bongo comes in our exquisite Leopard Burl finish. All other features are similar to the FWB190 Wood Bongos.



## 2. FREE RIDE SERIES (patented in Germany) FWB190 WOOD BONGOS

The MEINL FWB190 Free Ride Series Wood Bongos are perfect for the ambitious beginner and for those who are looking for an affordable second set. Its professional features are outstanding in this price range.



Black powder coated 2.5 mm rounded SSR-Rim



**Sizes** 6 3/4" Macho & 8" Hembra  
**Material** Rubber Wood (Hevea brasiliensis Muell.-Arg.)  
**Features** MEINL Free Ride Suspension System (patented in Germany)  
 Black powder coated hardware  
 Hand selected buffalo heads  
 8 mm strong tuning lugs  
 2.5 mm rounded SSR-Rims  
**Includes** Accessory pouch  
 L-shaped tuning key  
 Tune Up Oil  
**Colours** CB = Coffee Burst, high gloss  
 CR-M = Cherry Red, matte  
 LB = Leopard Burl, high gloss  
 SNT-M = Super Natural, matte



Chrome plated 2.5 mm rounded SSR-Rim



**Sizes** 6 3/4" Macho & 8" Hembra  
**Material** Rubber Wood (Hevea brasiliensis Muell.-Arg.)  
**Features** MEINL Free Ride Suspension System (patented in Germany)  
 Chrome plated hardware  
 Hand selected buffalo heads  
 8 mm strong tuning lugs  
 2.5 mm rounded SSR-Rims

**Includes** Accessory pouch  
 L-shaped tuning key  
 Tune Up Oil  
**Colours** ARF = Aztec Red Fade  
 GAB = Gold Amber Sunburst  
 NT = Natural  
**Finish** High gloss



Chrome plated rounded SSR-Rim



**Sizes** 3 1/2" Macho & 4 1/4" Hembra  
**Material** Rubber Wood (Hevea brasiliensis Muell.-Arg.)  
**Features** Free Ride Suspension System (patented in Germany)  
 True Skin Buffalo Heads  
 Rounded SSR-Rims  
 Chrome plated hardware  
**Includes** Tuning key  
**Colours** SNT-M = Super Natural  
 TSR-M = Tequilla Sunrise  
**Finish** Matte

## 3. FREE RIDE SERIES (patented in Germany) FWB200 WOOD BONGOS

The MEINL FWB200 Free Ride Series Wood Bongos are made from high quality components and produce a superb tone. The patented MEINL Free Ride System allows the bongo shells to resonate freely.

## 4. FREE RIDE SERIES (patented in Germany) MINI WOOD BONGOS

The MEINL Mini Wood Bongo is a smaller version of a full-sized bongo. It is equipped with professional features in miniature size just like the regular size standard model.

## 5. PROFESSIONAL BONGO BAG

The MEINL Bongo Bag fits all common bongo models and still has enough room for some hand percussion instruments. A padded separator is included.



Chester Thompson, USA



**Material** Heavy duty padded nylon  
**Features** Additional room for accessories  
 Padded shoulder strap  
 Carrying grip  
 Padded separator

MBB



Vladimir Zagitov

Ryan Kirschman

Afra

Ian Scott Shackleton

Maddison Jones



# Free Ride Series Bongos

## 1. ARTIST SERIES WOOD BONGO (Luis Conte)

The new MEINL Artist Series Luis Conte Signature Wood Bongo complements his congas with its black powder coated traditional style hardware and natural finish. Luis prefers the traditional style woodblock connection between the two shells.

<b>Sizes</b>	6 3/4" Macho & 8" Hembra
<b>Material</b>	Rubber Wood ( <i>Hevea brasiliensis</i> Muell.-Arg.)
<b>Features</b>	Solid woodblock connection True Skin Cow Heads 8 mm strong tuning lugs 4 mm traditional TTR-Rims Black powder coated hardware
<b>Includes</b>	Accessory pouch L-shaped tuning key Tune Up Oil
<b>Colour</b>	NT-M = Natural
<b>Finish</b>	Matte



## 2. FREE RIDE SERIES (patented in Germany) FWB300 WOOD BONGO

The MEINL FWB300 Free Ride Series Wood Bongo is equipped with traditional rims and the finest hand selected cow heads. It produces a warm yet full and voluminous sound. The patented MEINL Free Ride System allows the bongo shells to resonate freely.



<b>Sizes</b>	6 3/4" Macho & 8" Hembra
<b>Material</b>	Rubber Wood ( <i>Hevea brasiliensis</i> Muell.-Arg.)
<b>Features</b>	MEINL Free Ride Suspension System (patented in Germany) Chrome plated hardware True Skin Cow Heads 8 mm strong tuning lugs 4 mm traditional TTR-Rims

<b>Includes</b>	Accessory pouch L-shaped tuning key Tune Up Oil
<b>Colour</b>	NT-M = Natural
<b>Finish</b>	Matte

## 3. FREE RIDE SERIES (patented in Germany) FFB200 FIBERGLASS BONGOS

The MEINL FFB200 Fiberglass Bongos produce a compact sound with a nice spectrum of overtones. Ideal for the ambitious beginner who is looking for a semi-professional bongo at an affordable price.



<b>Sizes</b>	6 3/4" Macho & 8" Hembra
<b>Material</b>	Premium fiberglass
<b>Features</b>	MEINL Free Ride Suspension System (patented in Germany) Chrome plated hardware Hand selected buffalo heads 8 mm strong tuning lugs 2.5 mm rounded SSR-Rims
<b>Includes</b>	Accessory pouch L-shaped tuning key Tune Up Oil
<b>Colours</b>	BKSP = Black Sparkle BSP = Blue Sparkle STS = Sterling Silver



Extraordinary sparkling effect



<b>Sizes</b>	7" Macho & 8 1/2" Hembra
<b>Material</b>	Premium fiberglass
<b>Features</b>	MEINL Free Ride Suspension System (patented in Germany) Resonance Shaping Area Chrome plated hardware True Skin Cow Heads 8 mm strong tuning lugs 3 mm traditional SSR-Rims
<b>Includes</b>	Accessory pouch L-shaped tuning key Tune Up Oil
<b>Colour</b>	CA = Carbon finish

## 4. FIBERCRAFT DESIGNER SERIES BONGO (patented in Germany)

The new MEINL Fibercraft Designer Series Bongo comes in a dazzling new look. This bongo is made from premium fiberglass for dependability and great sound characteristics.

## 5. FREE RIDE SERIES (patented in Germany) FFB400 FIBERGLASS BONGOS

The MEINL FFB400 Free Ride Series Fiberglass Bongos have a stunning sound reaching from powerful mids to sharp highs. Thanks to their fiberglass shells they are extremely durable and the perfect instrument for the working musician on the road.

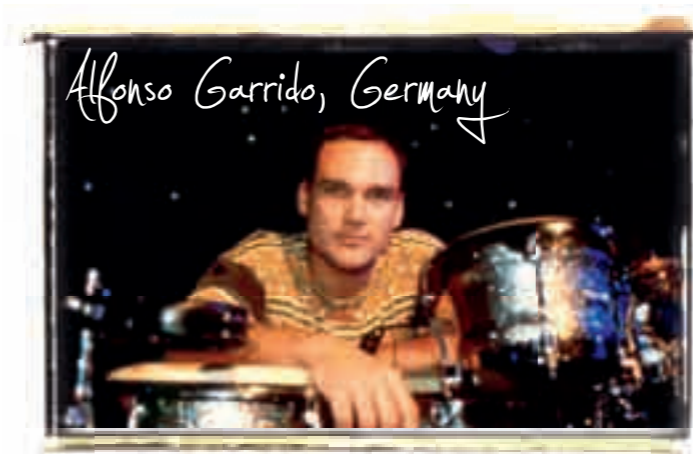

FFB400BSP



5.



<b>Sizes</b>	7" Macho & 8 1/2" Hembra
<b>Material</b>	Premium fiberglass
<b>Features</b>	MEINL Free Ride Suspension System (patented in Germany) Chrome plated hardware True Skin Cow Heads 8 mm strong tuning lugs 3 mm rounded SSR-Rims Resonance Shaping Area
<b>Includes</b>	Accessory pouch L-shaped tuning key Tune Up Oil
<b>Colours</b>	BKSP = Black Sparkle BSP = Blue Sparkle STS = Sterling Silver



Extraordinary sparkling effect

# Free Ride Series Wood Bongos

## 1. FREE RIDE SERIES (patented in Germany) FWB400 WOOD BONGOS

The MEINL FWB400 Free Ride Series Wood Bongos are the preferred bongo model by many top percussionists. Exceptional sound qualities combined with a wide variety of colours make it the perfect bongo for the working musician.



Chrome plated  
3 mm rounded  
SSR-Rim



FWB400EBK



FWB400NT



FWB400CR



FWB400GAB



FWB400ARF

Resonance  
Shaping  
Area



Dan Haffar

Jorge Bermudez, USA

Sizes 7" Macho & 8 1/2" Hembra  
Material Rubber Wood  
(*Hevea brasiliensis* Muell.-Arg.)  
Features MEINL Free Ride Suspension System (patented in Germany)  
Chrome plated hardware  
True Skin Cow Heads  
8 mm strong tuning lugs  
3 mm rounded SSR-Rims  
Resonance Shaping Area  
Includes Accessory pouch  
L-shaped tuning key  
Tune Up Oil  
Colours ARF = Aztec Red Fade  
CR = Cherry Red  
EBK = Ebony Black  
GAB = Gold Amber Sunburst  
NT = Natural  
Finish High gloss



Resonance  
Shaping  
Area

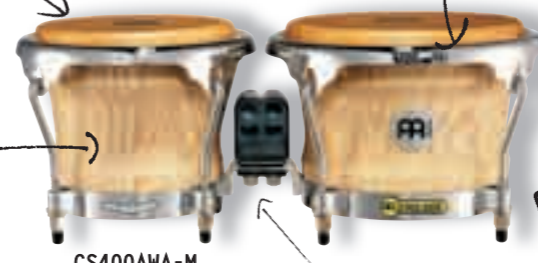

CS400AWA-M



Chrome plated  
3 mm rounded  
SSR-Rim

## 2. FREE RIDE COLLECTION SERIES (patented in Germany) WOOD BONGO

The MEINL Collection Series Wood Bongo is the finest bongo available today. It is made entirely by hand and exhibit unparalleled sound, charm, and workmanship.

## 3. FREE RIDE SERIES (patented in Germany) WOODCRAFT BONGO

The MEINL Woodcraft Bongo, just as the Woodcraft Congas, stands for tradition combined with exceptional workmanship. Only the finest hand selected materials are used to produce this premium bongo which produces the authentic and typical loud slapping bongo sound.

Sizes 7" Macho & 8 1/2" Hembra  
Material AWA-M = American White Ash  
(*Fraxinus americana* L.)  
Features MEINL Free Ride Suspension System (patented in Germany)  
Chrome plated hardware  
True Skin Cow Heads  
8 mm strong tuning lugs  
3 mm rounded SSR-Rims  
Resonance Shaping Area  
Includes Accessory pouch  
L-shaped tuning key  
Tune Up Oil  
Finish Matte

The Meinl Collection Series Wood Bongo won  
The IFA Award in the Best Percussion  
Product category.



3.



Chrome plated 4 mm  
traditional TTR-Rim



WB500ZFA-M



Sizes 7" Macho & 9" Hembra  
Material American White Ash  
(*Fraxinus americana* L.)  
Features MEINL Free Ride Suspension System (patented in Germany)  
Chrome plated hardware  
True Skin Cow Heads  
8 mm strong tuning lugs  
4 mm traditional TTR-Rims  
Resonance Shaping Area  
Includes Accessory pouch  
L-shaped tuning key  
Tune Up Oil  
Colour ZFA-M = Zebra Finished Ash  
Finish Matte

Chuck Praday, USA



Elisa Fischer

Hayley Bell



Emmanuel  
Pitsil



John  
Michael  
Laing



Chad Erik Askim



# Bongo Stands

## 1. PROFESSIONAL BONGO STAND

The MEINL Bongo Stand features a new design concept and simple functionality. The bongo is placed on a padded T-shaped tube and secured with a convenient knob screw. A stable metal clamp holds the entire unit securely in place.

- Material** Chrome plated steel  
**Features** Padded T-shaped tube  
 Fully height- and angle adjustable  
 Double braced tripod legs  
 Fits all common bongos  
**Includes** Allen wrench  
 Memory locks

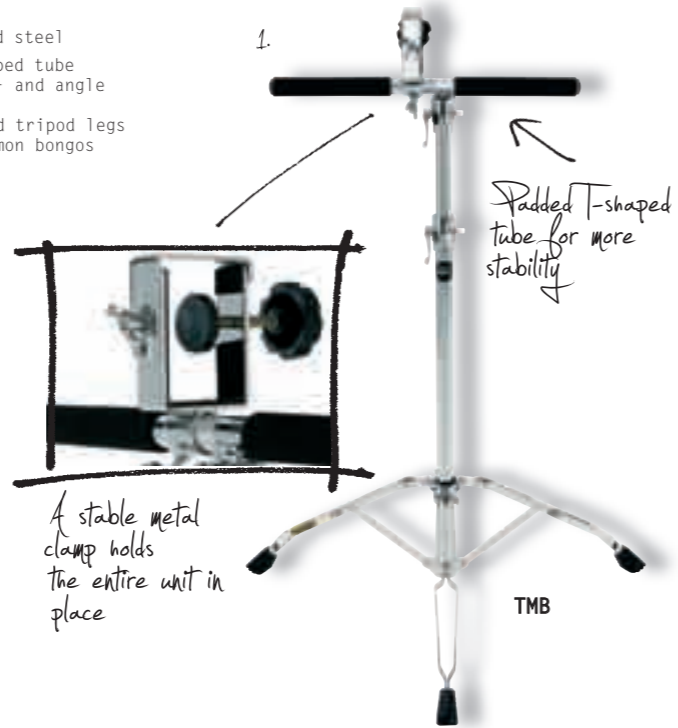

## 2. BONGO STAND (patented)

The MEINL Headliner® Series Bongo Stand combines easy handling and functionality with reliability and sturdy construction. A newly designed bracket enables extremely quick and easy mounting, yet holds the entire bongo securely in place.

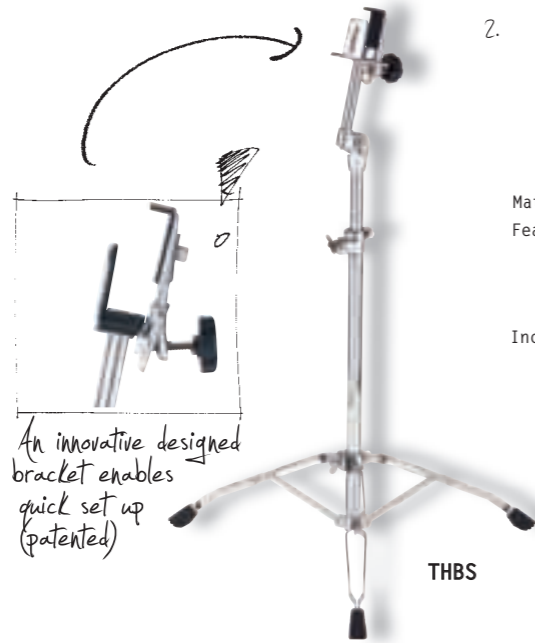

- Material** Chrome plated steel  
**Features** Quick set up  
 Easy handling  
 Reliable placement  
 Double braced tripod stand  
 Fits all common bongos  
**Includes** Wrench

## 3. PROFESSIONAL BONGO STAND FOR SEATED PLAYERS

This version of MEINL's Professional Bongo Stand has all the features of the regular model. However, it can be placed low enough to be comfortably played sitting down in the traditional position.

- Material** Chrome plated steel  
**Features** Seated playing position possible  
 Padded T-shaped tube  
 Fully height- and angle adjustable  
 Double braced tripod legs  
 Fits all common bongos  
**Includes** Allen wrench  
 Memory lock

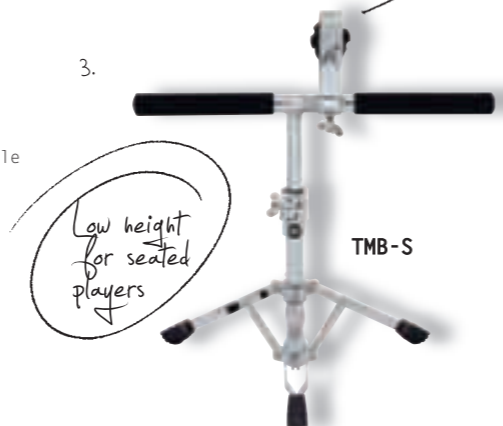

# Marcie Chapay USA



Marcie Chapay, a noted percussionist with love for music and passion for education in the arts. Music is her art, her dream, her life. After realizing her God-given talent at the early age of 12, she began pursuing a career in the music industry with relentless tenacity. School competitions, contests, not only challenged her but also financed her way to the illustrious New School for Jazz and Contemporary School of Music in New York City. While attending the school, she was chosen to represent NSJCSM in an exclusive summer program in Italy.

"My dream is to not only perform internationally but also pass along my talent to inspire".  
 Once you witness Marcie's performance, you will know that dreams do come true."



Christian Franz, Germany

Cajons



# Headliner® Series Cajons

The MEINL Headliner® Series Cajons deliver the classic cajon sound at an affordable price and can be used in Flamenco or world music. They are also very useful during unplugged gigs for delivering the rhythmic foundation for a whole band when a full drum set can't be used.



NEW!

Adjustable sizzle effect



Anti-slip sitting surface



Adjustable top corners

Stained American White Ash

Eco-friendly medium density fiberboard

Heavy duty rubber feet for a solid base

**Materials** HCAJ1AWA  
 Frontplate: Stained American White Ash (*Fraxinus Americana* L.)  
 Resonating body: Eco-friendly medium density fiberboard  
 HCAJ1MH-M  
 Frontplate: Mahogany  
 Resonating body: Rubber Wood (*Hevea brasiliensis* Muell.-Arg.)  
 HCAJ1NT  
 Frontplate: Rubber Wood (*Hevea brasiliensis* Muell.-Arg.)  
 Resonating body: Rubber Wood (*Hevea brasiliensis* Muell.-Arg.)  
**Features** Adjustable top corners  
 Adjustable sizzle effect  
 Anti-slip sitting surface  
**Includes** Allen wrench  
**Finish** Matte

The MEINL Protection Cover for Headliner® Cajons offers dependable protection (see page 60)



# Headliner® Designer Series Cajons

The MEINL Headliner® Designer Series Cajons are available in six different motifs. The two cloth-covered models produce a drier and crisper sound compared to conventional bare wood construction, while the other four cajons are made out of eco-friendly medium density fiberboard with appliqué graphics.



NEW!

NEW!

NEW!

**Materials** HCAJ2-WD/HCAJ2-SK/HCAJ2-US/  
 HCAJ2-UK: Eco-friendly medium density fiberboard with appliqué graphics  
 HCAJ2-FP/HCAJ2-OC:  
 Cloth-covered Rubber Wood (*Hevea brasiliensis* Muell.-Arg.)  
**Features** Snappy graphic style  
 Internal snare wires  
 Adjustable top corners  
**Finish** FP = Flower Power  
 OC = Original Camo  
 SK = Skulls Finish  
 UK = Unity Finish  
 US = Stars'n Stripes  
 WD = White Dragon

Eco-friendly medium density fiberboard with appliqué graphics

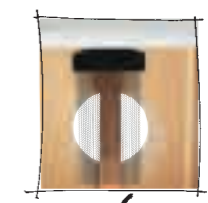
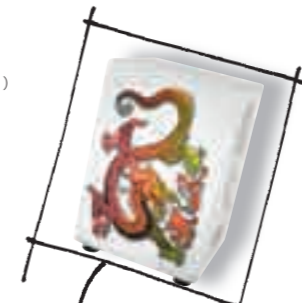

Internal snare wires

Flower Power



Original Camo

NEW!

The Chinese characters stand for "Dragon and Fire"

Cajons

HEADLINER® SERIES CAJONS  
 HEADLINER® DESIGNER SERIES CAJONS

# String Cajons

Padded sitting surface



CAJ3MB-M



CAJ3VSB-M

**Materials** CAJ3MB-M  
 Frontplate: Makah-Burl  
 Resonating body: Rubber Wood  
 (*Hevea brasiliensis* Muell.-Arg.)  
 CAJ3VSB-M  
 Frontplate: Birch  
 VSB = Vintage Sunburst  
 Resonating body: Rubber Wood  
 (*Hevea brasiliensis* Muell.-Arg.)  
**Features** Adjustable top corners  
 Adjustable sizzle effect  
 Integrated string mute system  
 (patent pending)  
 Wide sound options  
 Padded sitting surface  
**Includes** Allen wrench  
**Finish** Matte

Birch provides a sound colour with enhanced projection

Adjustable sizzle effect with integrated string mute system (patent pending)



## 1. STRING CAJONS (patent pending)

MEINL Cajons feature a built-in adjustable sizzle effect. Strings, which touch the frontplate on the inside and span from top to bottom, deliver a sensitive rattle that can be adjusted to fit various musical applications. The patented integrated string mute system controls the tension of the strings and ensures a dry and crisp sizzle effect.

## 2. STRING FIBERGLASS CAJON (patent pending)

This MEINL Cajon features a frontplate made from premium fiberglass and resonating body made from Rubber Wood, resulting in a modern look and additional sound options.

2.



CAJ7NT-BK

Adjustable top corners

**Materials** Frontplate: Premium fiberglass  
 Resonating body: Rubber Wood  
 (*Hevea brasiliensis* Muell.-Arg.)  
**Features** Adjustable top corners  
 Adjustable sizzle effect  
 Integrated string mute system  
 (patent pending)  
 Wide sound options  
 Padded sitting surface  
**Includes** Allen wrench

Premium fiberglass

Heavy duty rubber feet for a solid base

# String Cajons

## Bundle with bag

Adjustable top corners



CAJ3MB-M+BAG bundle with MCJB



CAJ3VSB-M+BAG bundle with MCJB

Juan Carlos Melian, Spain



Includes: Professional Cajon Bag made out of heavy duty padded nylon

4.



CAJ7NT-BK+BAG bundle with MCJB

## 3. STRING CAJONS BUNDLE WITH BAG (patent pending)

## 4. STRING FIBERGLASS CAJON BUNDLE WITH BAG (patent pending)

The MEINL Cajon Bag is the perfect solution for transporting these valuable instruments.

# The Next Generation

## 1. ERGO-SHAPE STRING CAJON (patented in Germany)

The MEINL Ergo-Shape String Cajon features an exotic Bubinga frontplate and two innovations: The frontplate is ergonomically curved for maximum comfort and sound development, and the string mute system gives your sound extra precision and control. The Bubinga frontplate is a rich and beautiful reddish coloured African wood.

1.



CAJ300BU-M

Padded sitting surface ✓  
Bubinga

Adjustable sizzle effect with integrated string mute system (patent pending)



## 2. ERGO-SHAPE PEDAL CAJON (patented in Germany)

The MEINL Ergo-Shape Pedal Cajon features our German patented ergonomic curved frontplate, made from exotic African Bubinga Wood. The ergonomically shaped frontplate has a slight curve (Ergo-Shape) that follows the natural contour of your hands for extreme comfort when playing - you will feel the difference!

2.



Ergo-Shape (patented in Germany)



CAJ100BU-M

Materials Frontplate: Bubinga  
Resonating Body: Rubber Wood (Hevea brasiliensis Muell.-Arg.)  
Features Ergo-Shape (patented in Germany)  
Adjustable sizzle effect  
Integrated string mute system (patent pending)  
Adjustable top corners  
Padded sitting surface  
Includes Allen wrench  
Finish Matte

Adjustable top corners

Foot pedal for a quick on/off switch of the snare wires (patent pending)



Heavy duty rubber feet for a solid base

Materials Frontplate: Bubinga  
Resonating Body: Rubber Wood (Hevea brasiliensis Muell.-Arg.)  
Features Ergo-Shape (patented in Germany)  
Foot pedal (patent pending)  
Internal adjustable snare wires  
Adjustable top corners  
Padded sitting surface  
Finish Matte

## NEW!

3.



CAJ4R0-M

Red Oak



Castanet-like striking surface (patent pending)

Inventor



Oliver Böttger

Material Frontplate and resonating Body: Red Oak (Quercus rubra)  
Features Castanet-like striking surface (patent pending)  
Internal snare wires  
Wide sound options  
Padded sitting surface  
Finish Matte

## 3. TURBO CAJON (patent pending)

The new MEINL Turbo Cajon goes an extra step towards cutting edge. The concept comes from instrument designer Oliver Böttger. We made this cajon with upper corners that have deeply cut channels with castanet-like striking surfaces. This produces a reinforced slap effect that you control with hand pressure.

## 4. BASS PEDAL CAJON (patent pending)

A pedal attached to the cajon adjusts the amount of pressure used to press the snare wires against the front plate, and can even be turned off completely. This system allows the player to change the settings of the snare wires while playing a rhythm with both hands without interruption. Due to its size being bigger than the standard MEINL Cajons, the instrument has more projection and bass frequencies.

Also available for this model, our Deluxe Bass Pedal Cajon Bag (see page 60)



Materials Frontplate: Ebony  
Resonating body: Rubber Wood (Hevea brasiliensis Muell.-Arg.)  
Features Foot pedal (patent pending)  
Internal, adjustable snare wires  
Great bass tones  
Adjustable top corners  
Padded sitting surface  
Wide sound options  
Finish Matte

More volume for more bass



CAJ5EB-M

Adjustable top corners

Foot pedal for a quick on/off switch of the snare wires (patent pending)



Heavy duty rubber feet for a solid base

# Snare Cajons

The snares touch the frontplate from the inside and deliver the classical cajon sound, which is requisite in Flamenco music. A knurled knob adjusts the amount of pressure used to press the snare wires against the frontplate. The rattle effect ranges between light and sensitive to very loud can be achieved through adjustment. The entire snare unit can even be turned off completely.



- Materials**
- CAJ1BR-M  
Frontplate: Black Rimba  
Resonating body: Rubber Wood (Hevea brasiliensis Muell.-Arg.)
  - CAJ1CA-M  
Frontplate: Premium fiberglass  
Resonating body: Rubber Wood (Hevea brasiliensis Muell.-Arg.)
  - CAJ1EB-M  
Frontplate: Ebony  
Resonating body: Rubber Wood (Hevea brasiliensis Muell.-Arg.)
  - CAJ1SNT-M  
Frontplate: American White Ash (Fraxinus americana L.)  
Resonating body: Rubber Wood (Hevea brasiliensis Muell.-Arg.)
  - CAJ1WE-M  
Frontplate: White Ebony  
Resonating body: Rubber Wood (Hevea brasiliensis Muell.-Arg.)
- Features** Adjustable top corners  
Internal, adjustable snare wires  
Padded sitting surface  
Wide sound options
- Finish** Matte



# Collection Cajons

All MEINL Collection Cajons feature very elegant veneers, both for the frontplate and for the resonating body. These cajons will attract attention in any performing situation.

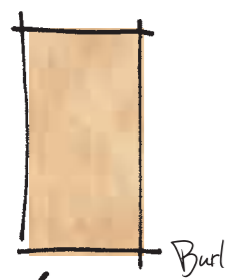

CAJ2BB-M



CAJ2ELM-M

Padded sitting surface



CAJ2R0-M



NEW!



CAJ20B-M

White Burl



Materials CAJ2BB-M  
 Frontplate: OceanBlu Burl  
 Resonating body: Burl  
 CAJ2BE-M  
 Frontplate and resonating body: Black Ebony  
 CAJ2ELM-M  
 Frontplate: Elm  
 Resonating body: Rubber Wood (Hevea brasiliensis Muell.-Arg.)  
 CAJ20B-M  
 Frontplate: Orange Burl  
 Resonating body: White Burl  
 CAJ2R0-M  
 Frontplate: Cherry  
 Resonating body: Red Oak (Quercus rubra)

Features Adjustable top corners  
 Internal, adjustable snare wires  
 Padded sitting surface  
 Wide sound options  
 Finish Matte

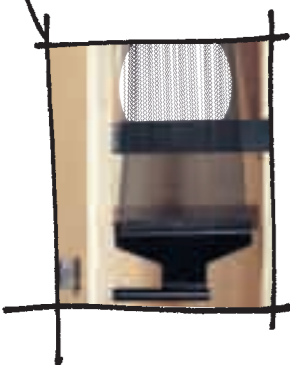

Fully adjustable snare wires

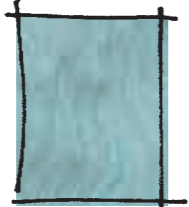

OceanBlu Burl



NEW!

Padded sitting surface

CAJ2BE-M

Black Ebony

Heavy duty rubber feet for a solid base



Craig Connet, UK

# Pickup Cajons

The MEINL Pickup Cajons are equipped with the DST pickup microphone and the A1.2 pre-amp system with volume control from UKKO by B-Band®. This active system includes a specially designed pre-amp, high quality endpin output jack and a durable battery. The system adds very little weight to the instrument. The sound reproduction is amazingly pure and clear. This installed microphone system provides comfortable and easy handling in live situations. Plug in and play!

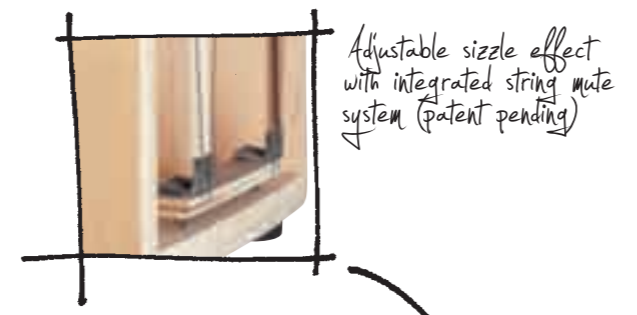

DST pickup microphone from UKKO

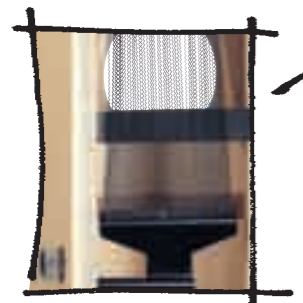
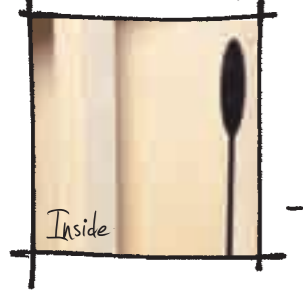

Fully adjustable snare wires

CAJ9SNT-M



CAJ8MB-M



Heavy duty rubber feet for a solid base



Rear view

Active A1.2 pre-amp system with volume control from UKKO

- Materials** CAJ9SNT-M  
 Frontplate: American White Ash (*Fraxinus americana* L.)  
 Resonating body: Rubber Wood (*Hevea brasiliensis* Muell.-Arg.)
- CAJ8MB-M  
 Frontplate: Makah-Burl  
 Resonating body: Rubber Wood (*Hevea brasiliensis* Muell.-Arg.)
- Features** CAJ9SNT-M  
 DST pickup microphone  
 Active A1.2 pre-amp system with volume control from UKKO  
 Adjustable top corners  
 Internal, adjustable snare wires  
 Padded sitting surface  
 Wide sound options

- Includes**  
 CAJ9SNT-M  
 9-volt battery
- CAJ8MB-M  
 9-volt battery  
 Allen wrench
- Finish** Matte

# Trejon

The MEINL Trejon is a breakthrough cajon development from Arend Schmidt-Landmeier. Three separate faceplates create three distinct tonal effects. It is similar to a drum set in that bass, snare, and tom sounds are in easy reach on the comfortably angled playing surface. The Ebony faceplates are exotic and stylish.

- Materials** Frontplates: Ebony  
 Resonating Body: Rubber Wood (*Hevea brasiliensis* Muell.-Arg.)
- Features** Three separate face plates on angled playing surface  
 Bass, snare, and tom effect  
 Internal adjustable snare wires  
 Angled frontplate for more playing comfort  
 Great bass tones  
 Adjustable top corners  
 Padded sitting surface  
 Wide sound options
- Finish** Matte



Arend Schmidt-Landmeier

Inventor

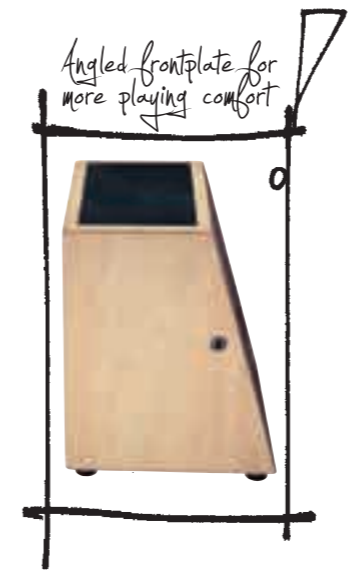

Angled frontplate for more playing comfort

Bass, snare, tom - all in one!

Padded sitting surface



TRECAJ1EB-M

Great bass tones due to the big size

Heavy duty rubber feet for a solid base



# Specialty Cajons

## 1. SNARE BONGO CAJON

The MEINL Snare Bongo Cajon can be played like a bongo, between the legs, or on one's lap. It comes with two snares secured to the inner side of the playing surface, for an authentic cajon sound and feel.

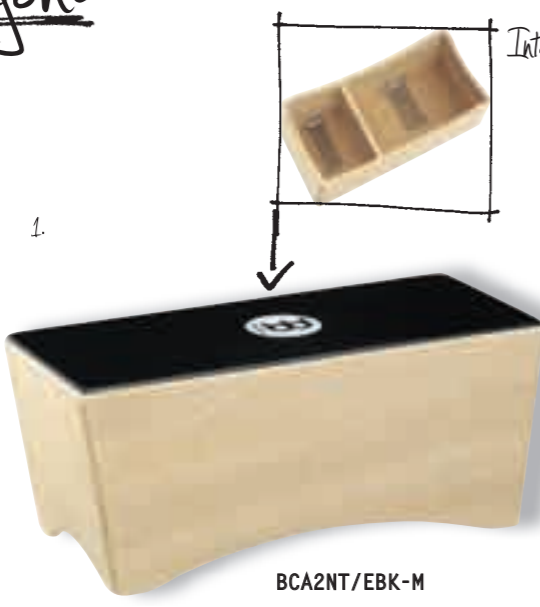

**Material** Rubber Wood  
(*Hevea brasiliensis* Muell.-Arg.)  
**Features** Internal snare wires  
High- and low pitch playing surface  
Compact size and light weight  
**Colour** NT/EBK-M = Natural/Ebony Black  
**Finish** Matte

## 2. BONGO CAJON

The MEINL Bongo Cajon is uniquely different. It delivers the sound one can expect from a traditional cajon, and with a playing surface that has high- and low pitch sound areas, traditional bongo patterns can be played on it as well

BCA2NT/EBK-M

NEW!

## 3. PALITO

The MEINL Palito is another addition to the comprehensive variety of our cajon instruments. Strings which touch the playing surface on the inside deliver a sensitive sizzle effect that fits to various musical applications. Its compact size and light weight makes it the perfect companion on the road.



Two different sized chambers enable an authentic bongo effect

**Material** Rubber Wood  
(*Hevea brasiliensis* Muell.-Arg.)  
**Features** High- and low pitch playing surface  
Compact size and light weight  
**Colour** SNT-M = Super Natural  
**Finish** Matte

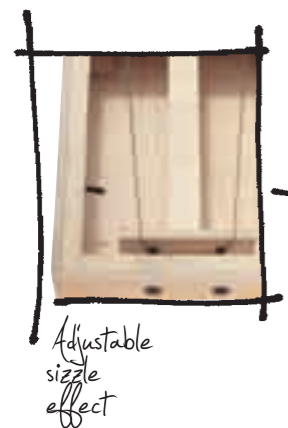

**Materials** Playing surface: Makah-Burl  
Resonating body: Rubber Wood  
(*Hevea brasiliensis* Muell.-Arg.)  
**Features** Adjustable sizzle effect  
Compact size  
**Includes** Allen wrench  
**Finish** Matte

Charly Böck, Germany



Fully adjustable snare wires



NEW!

CCA1NT

**Material** Rubber Wood  
(*Hevea brasiliensis* Muell.-Arg.)  
**Features** Soft nylon cord  
Solid piano hinge  
Easy-grip handle  
**Includes** Wooden striker  
**Finish** Matte

## 5.



The Meinl Conga Cajon won the MIPA Award in the "Best Percussion Product" category.

U-shaped notch allows quick set up and breakdown (US patent)

Height adjustable (patent pending)

L-shaped legs (patented)

**Materials** Playing surface: Black Makah-Burl  
Resonating Body: Rubber Wood  
(*Hevea brasiliensis* Muell.-Arg.)  
**Features** Internal, adjustable snare wires  
Adjustable top corners  
**Finish** Matte

Mark Essien, Germany



**Material** Black powder coated  
**Features** Metal spike attached to each leg  
L-shaped legs (patented)  
U-shaped notch for quick set up and breakdown (US patent)  
Notches for quick height adjustability (patent pending)  
**Includes** Allen wrench

## 6. CONGA CAJON STAND (patented)

The MEINL Conga Cajon Stand has many of the same features as the Steely II Conga Stands (patented). It was designed to enable a comfortable placement of MEINL Conga Cajon when played by itself or when incorporating it into a percussion rig.

## 4. CAJITA

The MEINL Cajita is developed from the classic Peruvian folk instrument. It hangs from the neck and is played with a wooden striker in one hand. The other hand controls the handle on the lid, opening and closing to create a wide variety of sounds, effects, and moods.

## 5. CONGA CAJON

The MEINL Conga Cajon can fit gracefully together with congas in a traditional trio configuration, or be played on its own. It features MEINL's innovative internal and adjustable snare wire system for enhanced sound possibilities.

# Cajon Bags

## 1. DELUXE BASS PEDAL CAJON BAG

The MEINL Deluxe Cajon Bag for the CAJ5 is perfectly suited for the bigger sized Bass Pedal Cajon. It features an additional layer of synthetic fur, which removes surface moisture and provides additional protection.

1.



MDLXCJB-L

**Material** Heavy duty padded nylon  
Synthetic fur  
**Measures** 21 1/2" W x 17" H x 14 1/2" D  
**Features** Padded shoulder strap  
External pocket  
Carrying grip

X Synthetic fur for additional protection

2.



MDLXCJB

**Material** Heavy duty padded nylon  
Synthetic fur  
**Measures** 20 1/2" W x 12" H x 12" D  
**Features** Padded shoulder strap  
External pocket  
Carrying grip

Carrying grip

Padded shoulder strap

## 2. DELUXE CAJON BAG

The MEINL Deluxe Cajon Bag features an additional layer of synthetic fur, which removes surface moisture and provides extra protection. Additional features are a padded shoulder strap and an external pocket for accessories.

## 3. PROTECTION COVER FOR HEADLINER® CAJONS

The MEINL Protection Cover for Headliner® Cajons offers dependable protection at an affordable price, assuring your cajon will look as good as it sounds for a long time to come.

3.



MCJPC

**Material** Heavy duty nylon  
**Colour** Black

## 4. PROFESSIONAL CONGA CAJON BAG

The Professional Conga Cajon Bag stores this valuable instrument securely and prevents it from being damaged during travel.

4.



MCJB-D

**Material** Heavy duty padded nylon  
**Features** Padded shoulder strap  
External pocket  
Carrying grip

5.



MCJB

**Material** Heavy duty padded nylon  
**Measures** 20 1/2" W x 12" H x 12" D  
**Features** Padded shoulder strap  
External pocket  
Carrying grip

Carrying grip

Padded shoulder strap

## 5. PROFESSIONAL CAJON BAG

The MEINL Cajon Bag is the perfect solution for transporting these valuable instruments. Its heavy duty padded outside walls store it securely and prevents damage.

## 6. DESIGNER CAJON BAGS

The MEINL Designer Cajon Bags are available in two different finishes. Handy grips and shoulder strap make them easy to carry.

Safari style :-)

**NEW!**

Original Camo



MCJB-GI

**Material** Heavy Duty padded nylon  
**Measures** 20 1/2" W x 12" H x 12" D  
**Features** Padded shoulder strap,  
External pocket  
Carrying grip  
**Colours** C1 = Original Camo  
GI = Giraffe



MCJB-C1







Claudia Rapps, Germany

Andrea Lang, Germany

Anna Puschner, Germany

# Djembes



drum circle

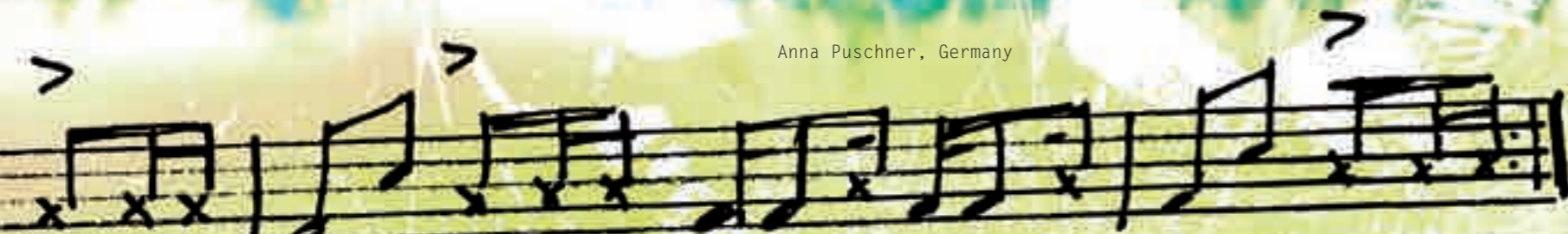

r r | r v

Djembes

# Headliner® Series Rope Tuned Djembes

## CONGO SERIES

The new MEINL Headliner® Series Rope Tuned Djembes are carved from one solid piece of plantation grown Mahogany Wood and feature the traditional Mali Weave tuning system.

**NEW!**

Hand selected goat head



HDJ1-XL

Sizes	Tall
M = 10"	20"
L = 12"	24"
XL = 13"	25"

PP Rope	Thickness	Runners
M	4 mm	18
L	5 mm	20
XL	6 mm	24

Materials Mahogany Wood

Features Carved from one solid piece of plantation grown Mahogany Wood  
Hand selected goat heads  
Pre-stretched PP nylon ropes  
Hand carved shells  
Ornamental carving

Colour Dark Brown



HDJ1-L



HDJ1-M

Carved from one solid piece of plantation grown Mahogany Wood

Hand carved shells

Thilo Wirsing

Esther Göbel

Franziska Lorenz

Helen Gibson

Saboula Bangoura

Rachel Bangoura

**NEW!**

## TRIBAL SERIES

The black MEINL Headliner® Series Rope Tuned Djembes are painted with a tribal design and feature the traditional Mali Weave tuning system. The black body is made out of one solid piece of Mahogany Wood.

4 mm pre-stretched PP nylon ropes

Materials Mahogany Wood

Features Carved from one solid piece of plantation grown Mahogany Wood  
Hand selected goat heads  
Pre-stretched PP nylon ropes  
Hand carved shells

Colour Black with tribal painting



HDJ2-M



HDJ2-L



HDJ2-XL

Tribal painting



Djembes

HEADLINER® SERIES ROPE TUNED DJEMBS



# Original African Style Rope Tuned Wood Djembes

Bundle with Bag

## WATER RHYTHM SERIES

The MEINL Original African Style Rope Tuned Wood Djembes are carved from one solid piece of plantation grown Mahogany Wood. The Mali-Weave rope tuning system guarantees a proper and long long-lasting tuning of the instrument. The Water Rhythm Series features a carved design evocative of ocean waves, and all djembes come bundled with the Professional Djembe Bag.

## EARTH RHYTHM SERIES

These high quality instruments are crafted with great attention to detail and provide an outstanding, full-volume sound. The Earth Rhythm Series features a carved design in black and brown. Its earthy pattern is evocative of ploughed fields and stalks of grain.

SIZES	DIAMETER	TALL
M = 10"	9 1/4"-10 1/4"	20"
L = 12"	10 3/4"-12 1/4"	24"
XL = 13"	12 3/4"-14 1/4"	25"

HTP ROPE	THICKNESS	RUNNERS
M	4 mm	25
L	4 mm	35
XL	5 mm	35

Material Mahogany Wood  
 Features Carved from one solid piece of plantation grown Mahogany Wood  
 Hand selected goat heads  
 Pre-stretched HTP nylon ropes  
 Hand carved shells  
 Ornamental carving  
 Includes Professional Djembe Bag made out of heavy duty padded nylon  
 Colour Brown/Black



Hand selected goat head

Carved from one solid piece of plantation grown Mahogany Wood

Hand selected goat head

Hand carved ornament

Pre-stretched high quality HTP nylon rope

ADJ2-L+BAG bundle with MDJB-M

ADJ2-M+BAG bundle with MDJB-S

ADJ3-M+BAG bundle with MDJB-S

ADJ3-XL+BAG bundle with MDJB-M

ADJ2-XL+BAG bundle with MDJB-M

Material Mahogany Wood  
 Features Carved from one solid piece of plantation grown Mahogany Wood  
 Hand selected goat heads  
 Pre-stretched HTP nylon ropes  
 Hand carved shells  
 Includes Professional Djembe Bag made out of heavy duty padded nylon  
 Colour Brown

ADJ3-L+BAG bundle with MDJB-M

# Original African Style Rope Tuned Wood Djembes

## MOON RHYTHM SERIES

The MEINL Original African Style Rope Tuned Wood Djembes are carved from one solid piece of plantation grown Mahogany Wood. These high quality instruments are crafted with great attention to detail and provide an outstanding, full-volume sound. The Moon Rhythm Series features a carved design in a dark mystic finish.



Sizes	Diameter	Tall
M = 10"	9 1/4"-10 1/4"	20"
L = 12"	10 3/4"-12 1/4"	24"
XL = 13"	12 3/4"-14 1/4"	25"

HTP Rope	Thickness	Runners
M	4 mm	25
L	4 mm	35
XL	5 mm	35

ADJ4-XL+BAG  
bundle with MDJB-M

ADJ4-L+BAG  
bundle with MDJB-M

ADJ4-M+BAG  
bundle with MDJB-S

Hand carved ornament



**Material** Mahogany Wood  
**Features** Carved from one solid piece of plantation grown Mahogany Wood  
 Hand selected goat heads  
 Pre-stretched HTP nylon ropes  
 Hand carved shells  
 Ornamental carving  
**Includes** Professional Djembe Bag made out of heavy duty padded nylon  
**Colour** Black

# Professional African Style Djembes NEW!

**Size** L = 12", 24" tall  
 30 runners 5 mm HTP nylon rope  
**Material** Mahogany Wood  
**Features** Carved from one solid piece of plantation grown Mahogany Wood  
 Hand selected goat heads  
 Pre-stretched HTP nylon rope  
 1) Traditional style hewn  
 2) Special "village" carving  
**Colour** Brown



PROADJ1-L



PROADJ2-L

Carved from one solid piece of plantation grown Mahogany Wood

Special "village" carving

Prince Akongo, Togo

## 1. PROFESSIONAL AFRICAN DJEMBE

The new MEINL Professional African Djembe is expertly hewn from a solid piece of Mahogany Wood, and fitted with a hand-selected goatskin head. We use the traditional Mali Weave tuning system with high quality HTP rope. Thirty vertical runners keep the head in tune, properly balanced, and looking proud.

## 2. PROFESSIONAL AFRICAN DJEMBE

The new MEINL Professional African Djembe with "village" carving is expertly formed from solid piece of Mahogany Wood, and decoratively carved with a village scene. The hand-selected goatskin head is secured with the traditional Mali-weave tuning system. Thirty vertical runners of high quality HTP rope assure proper tuning, and keep your drum looking great.



Djembes

# Bougarabou & Wood Djembes

## 1. AFRICAN BOUGARABOU

The new MEINL Bougarabou is proudly made in the tradition of the Jola people of southern Senegal. The classic bougarabou features an elongated goblet-shaped body carved from Mahogany Wood. A bougarabou can be played with traditional conga or djembe techniques, and makes a rich complement within drum ensembles.

1.

**Size** L = 12", 24" tall  
22 runners, 5 mm HTP nylon rope

**Material** Mahogany Wood

**Features** Carved from one solid piece of plantation grown Mahogany Wood  
Hand selected cow head  
Pre-stretched HTP nylon rope  
Complex carving

**Colour** Brown

**NEW!**

Hand selected cow head



ABGB-L



Miloš Vacík, Czech Republic

**Size** 12" 24 1/4" tall

**Material** Rubber Wood (Hevea brasiliensis Muell.-Arg.)

**Features** True Skin Calf Heads  
Traditional rope tuning system

**Colours** AB-M = African Brown  
NT-M = Natural

**Finish** Matte

Traditional rope tuning system



DJWR3NT-M

DJWR3AB-M

# Headliner® Series Djembes

!!! All djembes are equipped with six tuning lugs for a good tuning system

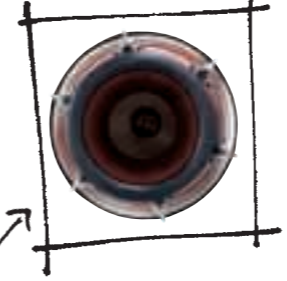

**Size** 12" 23 1/2" tall

**Material** Rubber Wood (Hevea brasiliensis Muell.-Arg.)

**Features** 8 mm strong tuning lugs  
2 mm rounded rims  
Original MEINL style tuning brackets  
Black powder coated hardware  
Hand selected goat heads

**Includes** Tuning key

**Colours** NT = Natural  
VSB = Vintage Sunburst  
WRB = Wine Red Burst

**Finish** High gloss



HDJ600WRB

HDJ600VSB

HDJ600NT

Rubber ringed bottom for more stability and protection

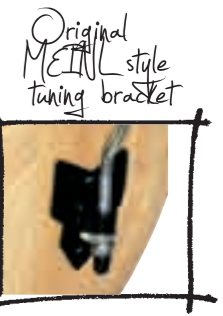

Original MEINL style tuning bracket

Black powder coated 2 mm rounded rim

Stylish Camo finish

**NEW!**

**Size** 12" 23 1/2" tall

**Material** Cloth-covered Rubber Wood (Hevea brasiliensis Muell.-Arg.)

**Features** 8 mm strong tuning lugs  
2 mm rounded rims  
Original MEINL style tuning brackets  
Black powder coated hardware  
Hand selected goat heads

**Includes** Tuning key

**Colour** MDC = Midnight Desert Camo

**Finish** High gloss

2.



HDJ600MDC

Djembes

# Floatune Series



Relocated tuning lugs offer perfect playing comfort

**Size** 12 3/4" / 25 1/4" tall  
**Material** Rubber Wood (Hevea brasiliensis Muell.-Arg.)  
**Features** True Skin Goat Heads, 8 mm strong tuning lugs, 3 mm rounded SSR-Rims, Easy tuning and comfortable change of heads, Rubber pads and lug placement offer perfect playing comfort, Floatune Tuning System, Chrome plated hardware  
**Includes** Accessory pouch, L-shaped tuning key, Tune Up Oil  
**Colours** AB-M = African Brown, matte; GAB-M = Gold Amber Sunburst, matte; NT = Natural, high gloss



Special rubber pads for perfect playing comfort

## 1. FLOATUNE SERIES 12 3/4" WOOD DJEMBES

The 12 3/4" MEINL Floatune Djembe is modeled after the West African originals. Deep, round-sounding bass notes complimented by crisp tones and slaps are produced by this drum.

## 2. FLOATUNE SERIES 12" WOOD DJEMBES

The proportions of this drum provide higher, brighter tones and slaps, while retaining a clear, full bass note. This model is a bit more compact and lighter in weight.



**Size** 12" / 24 1/4" tall  
**Material** Rubber Wood (Hevea brasiliensis Muell.-Arg.)  
**Features** True Skin Goat Heads, 8 mm strong tuning lugs, 3 mm rounded SSR-Rims, Easy tuning and comfortable change of heads, Rubber pads and lug placement offer perfect playing comfort, Floatune Tuning System, Chrome plated hardware

**Includes** Accessory pouch, L-shaped tuning key, Tune Up Oil  
**Colours** AB-M = African Brown, matte; GAB-M = Gold Amber Sunburst, matte; NT = Natural, high gloss



**Size** 12" / 24 1/4" tall  
**Material** American White Ash (Fraxinus americana L.)  
**Features** True Skin Goat Head, 8 mm strong tuning lugs, 3 mm rounded SSR-Rim, Easy tuning and comfortable change of heads, Rubber pads and relocated lugs offer perfect playing comfort, Floatune Tuning System, Chrome plated hardware  
**Includes** Accessory pouch, L-shaped tuning key, Tune Up Oil  
**Colour** ZFA-M = Zebra Finished Ash  
**Finish** Matte

Floatune Tuning System

SSR Safe & Sound-Rim  
 Chrome plated 3 mm rounded SSR-Rim

American White Ash



Nebojsa Jovan Zivkovic, Germany



**Size** 12" / 24 1/4" tall  
**Material** Premium fiberglass  
**Features** True Skin Goat Heads, 8 mm strong tuning lugs, 3 mm rounded SSR-Rims, Easy tuning and comfortable change of heads, Rubber pads and lug placement offer perfect playing comfort, Floatune Tuning System, Chrome plated hardware  
**Includes** Accessory pouch, L-shaped tuning key, Tune Up Oil  
**Colours** BSP = Blue Sparkle; RSP = Red Sparkle

The head can be tuned very simply

Extraordinary sparkling effect

Djembes

# Stands & Bags

## 1. STEELY II DJEMBE STAND (patented)

The Steely II Djembe stand (patented) features all of the same designs as the Steely II Conga stands (patented). It can be adjusted to accommodate various djembe sizes using three spacers and is fully height adjustable. It is perfect for drum circles and other street percussion activities.

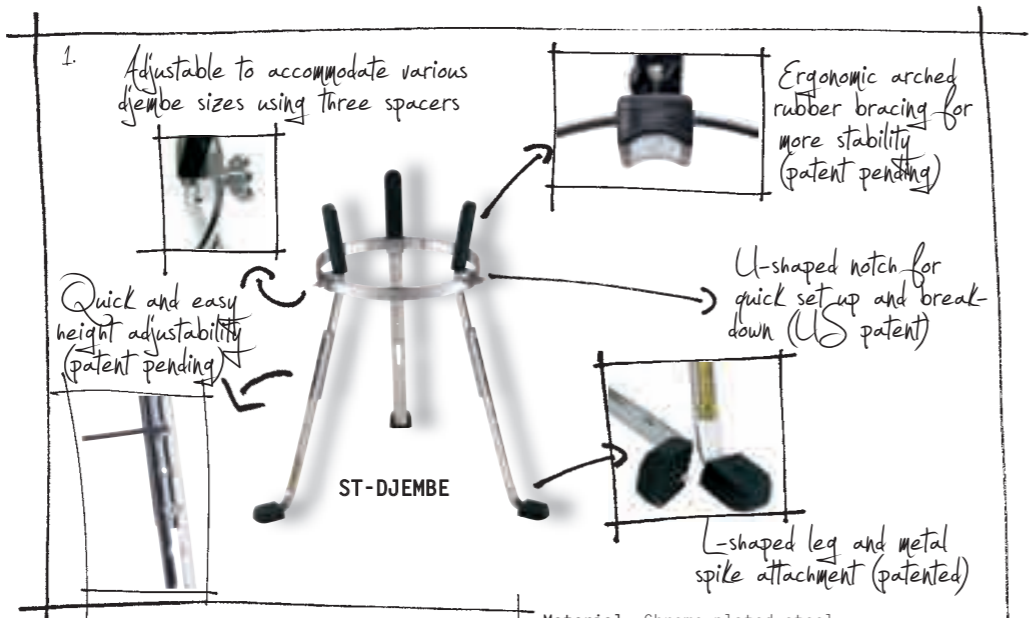

**Material** Chrome plated steel  
**Features** Metal spike attached to each leg  
 L-shaped legs (patented)  
 U-shaped notch for quick set up and breakdown (US patent)  
 Notches for quick height adjustability (patent pending)  
 Adapts to different djembe sizes  
**Includes** Allen wrench  
 3 spacers

## 2. PROFESSIONAL DJEMBE STAND

The MEINL Djembe Stand was designed to firmly hold any djembe in the traditional playing position. A nylon strap is secured around the drum and two rubber padded u-shaped hooks slide into the bottom of the shell. It can be angled, and is fully height adjustable.

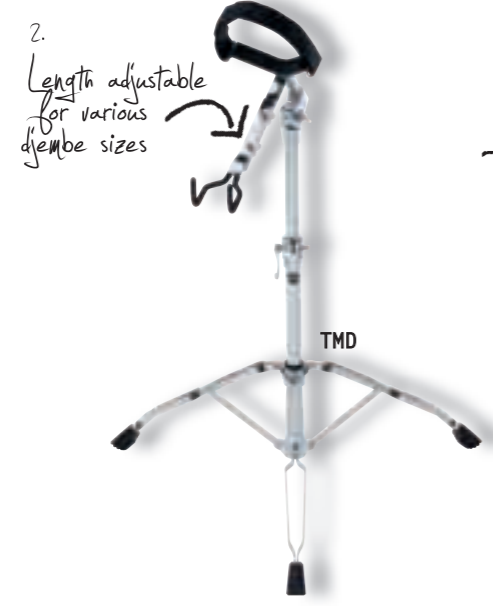

**Material** Chrome plated steel  
**Features** Rubber padded hooks  
 Fully height- and angle adjustable  
 Double braced tripod legs  
**Includes** Allen wrench  
 Memory lock

## 3. KESSING

The Kessing is a traditional djembe accessory that provides a dry rattling accompaniment to the drum. It slides securely into the webbing and is removable.

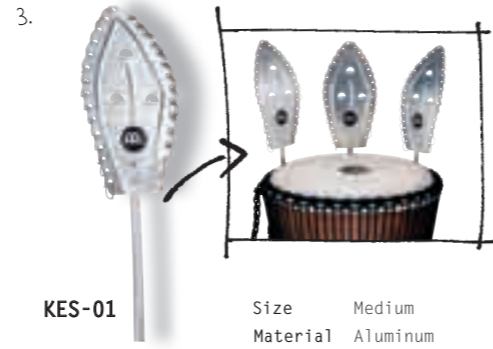

**Size** Medium  
**Material** Aluminum

## 4. PROFESSIONAL DJEMBE STRAP

The MEINL Djembe Strap comfortably and securely holds any djembe in the perfect playing position. It is fully adjustable and works on all common djembes. Thick pads ensure long lasting comfort while playing.



**Material** Cloth-covered nylon  
**Features** Quick change hook  
 Adjustable straps  
 Quick-release buckles  
**Colour** Multi colour



NEW!

**Sizes** M = 10"  
 L = 12"  
 XL = 13"  
**Material** Heavy duty padded nylon  
**Colour** Black



**5. PROFESSIONAL DJEMBE CAPS**  
 The new MEINL Professional Djembe Caps protect your drum with a heavy duty reinforced top and an extra-long skirt with an elastic waist band.

**6. PROFESSIONAL DJEMBE BAGS**  
 The MEINL Djembe Bags come in three sizes, medium, large, and small to fit all common djembe models. Additional features include padded backpack straps and an external pocket for accessories.

**7. DELUXE DJEMBE BAGS**  
 The MEINL Deluxe Djembe Bags feature an additional layer of synthetic fur, which removes surface moisture and provides additional protection. They come in medium and large sizes enabling them to fit all common djembe models. Additional features include padded backpack straps and an external pocket for accessories.



MDJB-M

**Sizes** Medium (up to 12")  
 Large (up to 13 1/2")  
**Materials** Heavy duty padded nylon  
 Synthetic fur  
**Features** External pocket  
 Padded backpack straps  
 Carrying grip



MDLXDB-M

MDLXDB-L



# Samba

The MEINL Samba Series is a line of innovative Brazilian percussion instruments. The variety of different and authentic sounds, innovative features and wide range of accessories combined with light weight materials designed for comfortable playing makes this series invaluable to all percussionists.



# Pandeiros

**NEW!**

1.

PA10AB-M



↑  
Internal lug tuning system

Sizes	10" 12"
Material	Rubber Wood ( <i>Hevea brasiliensis</i> Muell.-Arg.)
Features	Internal lug tuning system Hand hammered brass jingles Light weight
Includes	Allen wrench
Colour	AB-M = African Brown
Finish	Matte

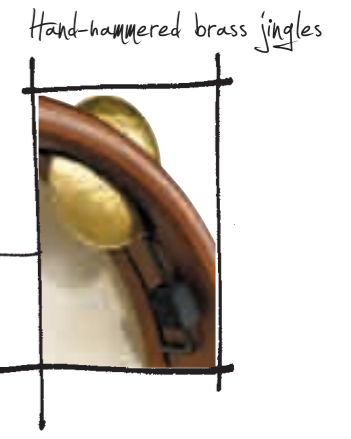

2.

PA10CN-M



↑  
Hand selected goat head

PA12CN-M

← Solid jingles

Sizes	10" 12"	Includes	Tuning key
Material	Rubber Wood ( <i>Hevea brasiliensis</i> Muell.-Arg.)	Colour	CN-M = Chest Nut
Features	Counter sunk bolt lugs Chrome plated hardware Replaceable hand selected goat heads	Finish	Matte

Applying the logo from underneath the head to prevent from wearing off (US patent)

3.

PA10ABS-BK



Size	10"
Material	ABS plastic
Features	Counter sunk bolt lugs Chrome plated hardware Replaceable synthetic head Applying the logo from underneath the head (US patent)
Includes	Tuning key
Colour	BK = Black

4.

MPAB-10



MPAB-12

Sizes	10" 12"	Features	Double-slide zipper Shoulder strap External pocket
Material	Heavy duty padded nylon		

## 1. SHELL-TUNED PANDEIROS

The new MEINL Shell-Tuned Pandeiros are great sounding pandeiros with internal tuning lugs. This frees the outside surface of the shell from protruding hardware, and saves weight. Hand selected goatskin heads have an authentic sound, and our super dry, hand-hammered brass jingles create a dazzling look and sound.

## 2. WOOD PANDEIROS

The Pandeiro is played with one hand while the other alters the pitch of the drum. Solid jingles produce a brilliant, dry and cutting sound.

## 3. ABS PANDEIRO (US patent)

The MEINL ABS Pandeiro is made for extensive and energetic playing. Solid jingles produce a brilliant, dry and cutting sound.

## 4. PROFESSIONAL PANDEIRO BAGS

The MEINL Professional Pandeiro Bags are made from heavy duty padded nylon with reinforced stitching and are equipped with a double-slide zipper and a shoulder strap. They protect your instruments and provide hassle free transportation.

# Samba

GILSON SILVEIRA  
SHELL-TUNED PANDEIROS, WOOD PANDEIROS, ABS PANDEIRO, PROFESSIONAL PANDEIRO BAGS



# Samba

## 1. FLOATUNE TAMBORIMS (US patent)

Tamborims are played with a plastic stick while the other hand changes the pitch of the drum. It has a bright, loud, and cutting sound. MEINL offers a variety of tamborims all made from several high quality materials for several sound options.

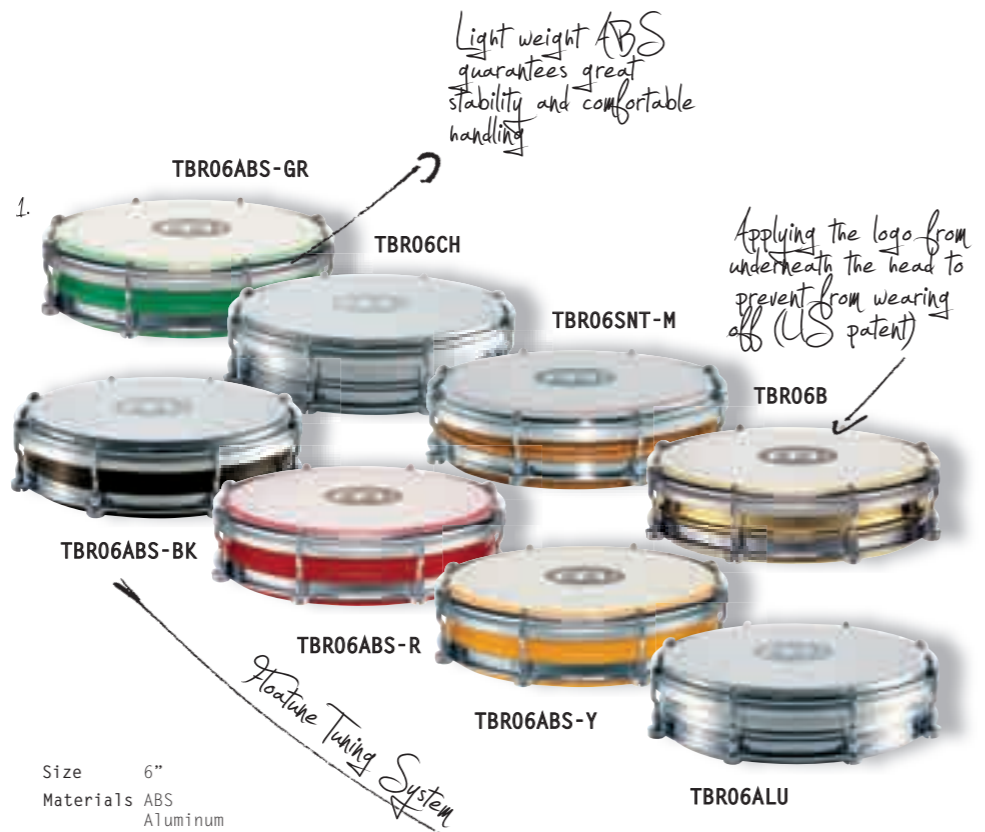

Size 6"  
Materials ABS, Aluminum, Brass plated steel, Chrome plated steel, Rubber Wood (Hevea brasiliensis Muell.-Arg.)  
Features Floatune Tuning System, Applying the logo from underneath the head (US patent), Counter sunk bolt lugs, Replaceable synthetic heads  
Includes German "Pfennig" as tuning key

## 2. TAMBORIM STICKS

## 3. SAMBA WHISTLE

The MEINL Samba Whistle has three tones in a super-bright timbre. This is the classic Samba sound and spirit. Solid aluminum construction ensures years of use.

## 4. PROFESSIONAL TAMBORIM BAG

The MEINL Tamborim Bag is made from heavy duty padded nylon with reinforced stitching and is equipped with a double-slide zipper.



Material Plastic  
Colours BK = Black, R = Red



Material Aluminum  
Includes Neck lanyard



Size 6"  
Material Heavy duty padded nylon  
Features Double-slide zipper, Shoulder strap, External pocket



Sizes Small, Large  
Material Special steel alloy  
Includes Mounting clamp for small model  
Finish Hand brushed steel



Sizes Small, Large  
Material Special steel alloy  
Feature Flexible connection  
Finish High polished chrome

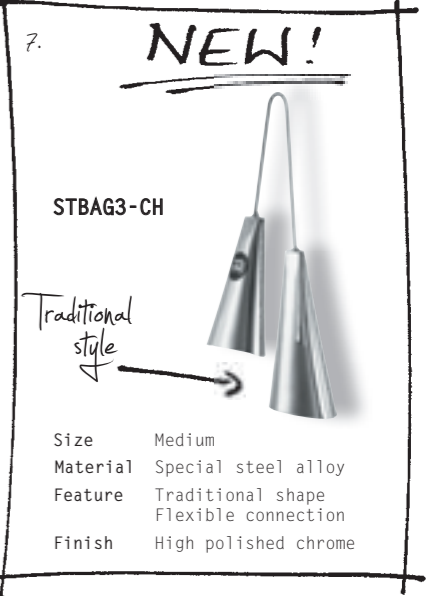

Size Medium  
Material Special steel alloy  
Feature Traditional shape, Flexible connection  
Finish High polished chrome

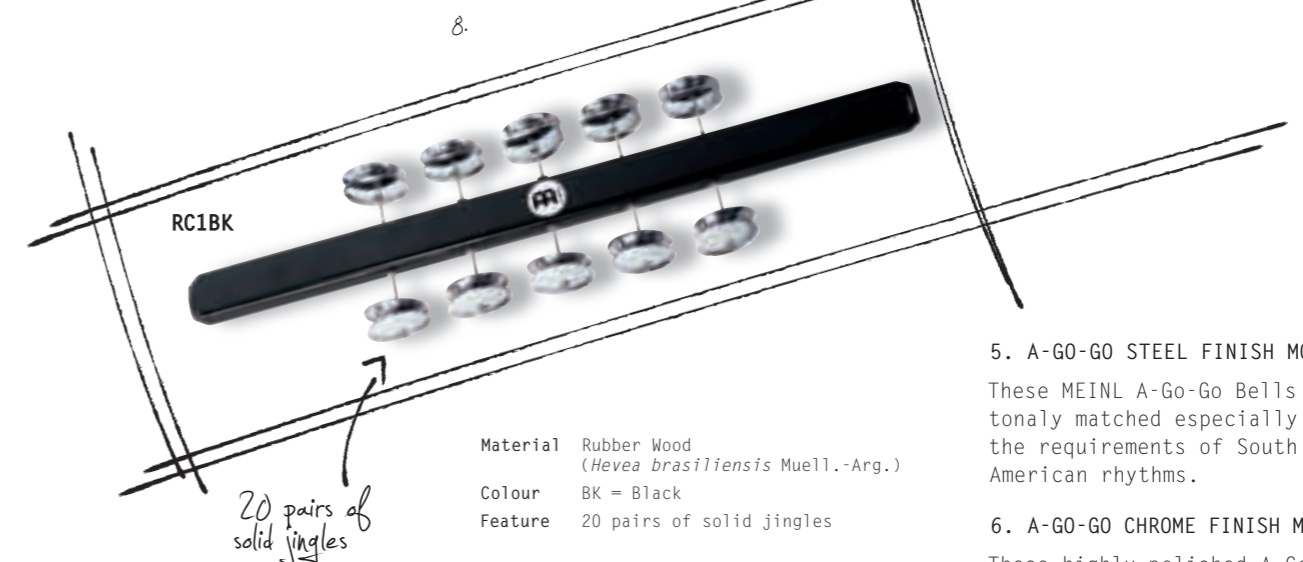

Material Rubber Wood (Hevea brasiliensis Muell.-Arg.)  
Colour BK = Black  
Feature 20 pairs of solid jingles

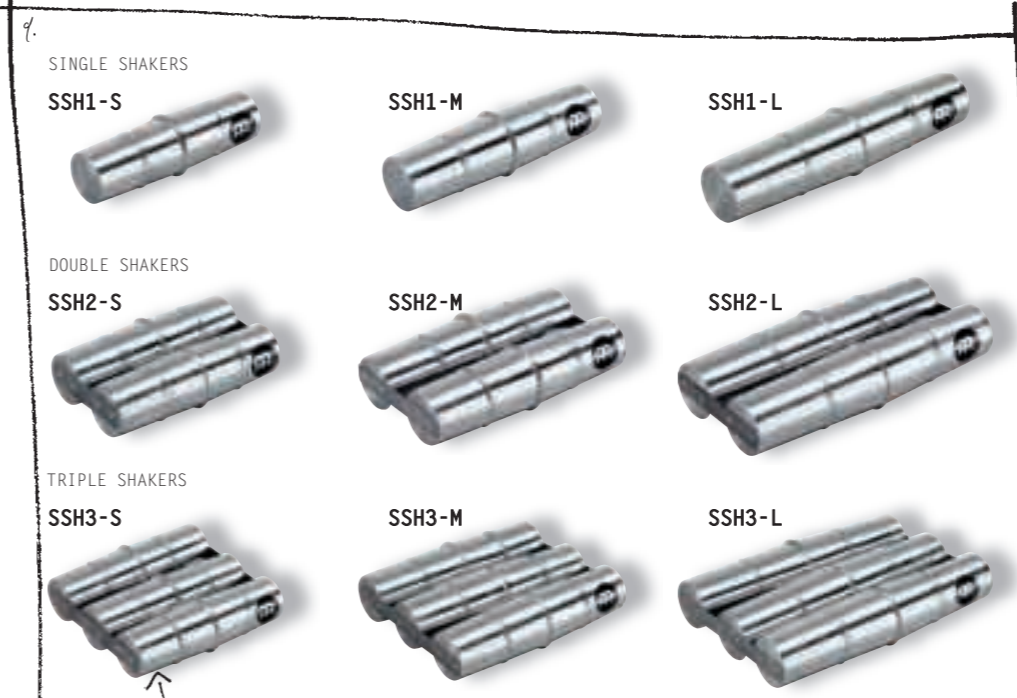

Sizes Small, Medium, Large  
Material Aluminum

## 5. A-GO-GO STEEL FINISH MODELS

These MEINL A-Go-Go Bells are tonally matched especially for the requirements of South American rhythms.

## 6. A-GO-GO CHROME FINISH MODELS

These highly polished A-Go-Go Bells offer a bright sound and are equipped with a flexible connection. Ideal for Samba style music.

## 7. TRADITIONAL STYLE A-GO-GO BELL

The new MEINL Traditional style A-Go-Go Bell in our new medium size is the perfect A-Go-Go Bell when the large is too much and the small one isn't enough.

## 8. ROCAR

The MEINL Rocar is equipped with 20 pairs of solid jingles mounted onto a wooden bar.

## 9. ALUMINUM SAMBA SHAKERS

The MEINL Samba Shakers are the ideal instruments for street Samba. Their shells are made from thin aluminum which, when combined with solid steel shot, produce a warm, penetrating, and cutting shaker sound.

# Samba



**QW7R**  
 Size 8"  
 Material Premium fiberglass  
 Features Floatune Tuning System  
 Hand selected goat head  
 Includes Tuning key  
 Colour R = Red



**QW6**  
 Sizes 6"  
 10"  
 Material Aluminum  
 Features Counter sunk bolt heads (QW10)  
 Hand selected goat heads  
 Includes Tuning key

**1. FIBERGLASS QWEEKA**  
 While one hand rubs the internal bamboo shaft with a moist cloth, the other hand controls the pressure of the head, thereby changing the pitch of the tone.

**2. ALUMINUM QWEEKAS**  
 MEINL offers two Qweekas made from light weight aluminum. Their light weight and solid construction makes them perfect for street Samba.



**Material** Plastic  
**Sizes** SST1-S = Stick, short version  
 SST1-R = Stick, regular version  
 SST1-L = Stick, long version  
 SST3-S = Triple stick, short version  
 SST3 = Triple stick  
 SST7 = Sevenfold stick

**3. SAMBA STICKS**  
 MEINL offers a wide assortment of Samba Sticks for Tamborims, Repiniques, and other Samba instruments in order to achieve their authentic sounds.

**4. PROFESSIONAL QWEEKA BAGS**  
 The Professional Qweeka Bags are a great way to protect your qweeka in transport. Made from heavy duty padded nylon with reinforced stitching, the bags offer extra protection with reinforced side walls. Padded shoulder strap and carrying grip for hassle-free transport.



**MQW-10**  
**Sizes** 6"  
 8"  
 10"  
**Material** Heavy duty padded nylon  
**Features** Padded shoulder strap  
 Carrying grip  
 External pocket

**MQW-7**  
**MQW-6**



# Caixas

## 1. ALUMINUM CAIXAS (US patent)

With shells made from premium aluminum, these MEINL Caixas produce the classic bright and cutting sound with penetrating rim shots that these instruments are supposed to deliver.

## 2. TRADITIONAL CAIXA (US patent)

The new MEINL traditional Caixa is faithful to the classic Brazilian style. Two pairs of guitar strings span one of the thin synthetic heads, for a strong snare effect and a crackling bright fundamental pitch. The deep shell gives a stronger resonance.

## 3. PROFESSIONAL CAIXA BAGS

The MEINL Caixa Bags are made from heavy duty padded nylon with reinforced stitching and are equipped with a double-slide zipper, a shoulder strap, and a carrying grip.



CA12

CA14

Sizes 12" x 4 1/2"  
14" x 4"  
Material Aluminum  
Features Replaceable synthetic heads  
Counter sunk bolt heads  
Steel snare wires  
Applying the logo from underneath the head (US patent)  
Professional snare throw-off mechanism  
Includes Tuning key

Professional snare throw-off mechanism



CA12T

**NEW!**

Size 12" x 6"  
Material Aluminum  
Features Traditional style snares made from guitar strings  
Extra deep body  
Counter sunk bolt heads  
Applying the logo from underneath the head (US patent)  
Replaceable synthetic heads  
Includes Tuning key

6" deep for more volume



MCA-12

MCA-12T

MCA-14

Extra pocket for spare heads

Sizes 12" x 4 1/2"  
12" x 6"  
14" x 4"  
Material Heavy duty padded nylon  
Features Double-slide zipper  
Extra pocket for spare heads  
Shoulder strap  
Carrying grip  
External pocket

**NEW!**

# Repiniques

## 1.



RE10

RE12

Sizes 10" x 10"  
12" x 12"  
Material Aluminum  
Features Counter sunk bolt heads  
Chrome plated hardware  
Replaceable synthetic heads  
6 tuning lugs (10" model)  
8 tuning lugs (12" model)  
Applying the logo from underneath the head (US patent)  
Includes Tuning key

Applying the logo from underneath the head to prevent from wearing off (US patent)

Light weight aluminum

Counter sunk bolt head

## 2.



RE12AB

Size 12" x 12"  
Material Rubber Wood (Hevea brasiliensis Muell.-Arg.)  
Features Counter sunk bolt heads  
Chrome plated hardware  
Replaceable synthetic heads  
8 tuning lugs  
Applying the logo from underneath the head (US patent)  
Includes Tuning key  
Colour AB = African Brown  
Finish High gloss

Counter sunk bolt head

## 3.



MREB-10

MREB-12

Sizes 10" x 10"  
12" x 12"  
Material Heavy duty padded nylon  
Features Double-slide zipper  
Shoulder strap  
Carrying grip  
External pocket

## 4.



SB-R

Material Cotton  
Features Length adjustable  
Adjustable shoulder padding  
Strong attachment hooks  
Colour R = Red

*Samba*

# Aluminum Surdos



**SU16**

Sizes 16" x 20"  
18" x 22"  
20" x 24"  
22" x 24"

Material Aluminum

Features Counter sunk bolt heads  
Chrome plated hardware  
Replaceable synthetic heads  
8 tuning lugs  
(16" & 18" models)  
10 tuning lugs  
(20" & 22" models)  
Applying the logo from underneath the head (US patent)

Includes Tuning key

Light weight aluminum

Applying the logo from underneath the head to prevent from wearing off (US patent)



**1. ALUMINUM SURDOS (US patent)**  
The deep sound of the Surdo is the heartbeat of Samba music. It is played with a felt beater. MEINL offers several sizes made from premium aluminum.

**2. STAND ALONE ALUMINUM SURDOS (US patent)**  
MEINL percussion offers stand alone Surdos that are equipped with sturdy, height adjustable legs placed on the floor while playing.

Sizes 16" x 20"  
18" x 22"  
20" x 24"  
22" x 24"

Material Aluminum

Features Height adjustable legs  
Counter sunk bolt heads  
Chrome plated hardware  
Replaceable synthetic heads  
8 tuning lugs  
(16" & 18" models)  
10 tuning lugs  
(20" & 22" models)  
Applying the logo from underneath the head (US patent)

Includes Tuning key

Height adjustable leg

# Wood Surdos **NEW!**



**SU16AB-M**

Sizes 16" x 20"  
18" x 22"  
20" x 24"  
22" x 24"

Material Six-ply hardwood shells

Features Counter sunk bolt heads  
Chrome plated hardware  
Replaceable synthetic heads  
8 tuning lugs  
(16" & 18" models)  
10 tuning lugs  
(20" & 22" models)  
Applying the logo from underneath the head (US patent)

Includes Tuning key

Colour AB = African Brown

Six-ply hardwood shells for a full and warm sound

Applying the logo from underneath the head to prevent from wearing off (US patent)



Sizes 16" x 20"  
18" x 22"  
20" x 24"  
22" x 24"

Material Six-ply hardwood shells

Features Height adjustable legs  
Counter sunk bolt heads  
Chrome plated hardware  
Replaceable synthetic heads  
8 tuning lugs  
(16" & 18" models)  
10 tuning lugs  
(20" & 22" models)  
Applying the logo from underneath the head (US patent)

Includes Tuning key

Colour AB = African Brown

Counter sunk bolt head

**1. WOOD SURDOS (US patent)**  
The new MEINL Wood Surdos have all the great features of our Aluminum Surdos, but with wooden shells for a warmer sound. They deliver the full bass notes that are the heartbeat of Samba music, and are light enough for extended play.

**2. STAND ALONE WOOD SURDOS (US patent)**  
The new MEINL Stand Alone Wood Surdos have all the great features of our Stand Alone Aluminum Surdos, but with wooden shells for a warmer sound. They deliver the full bass notes that are the heartbeat of Samba music. The MEINL Stand Alone Surdos are perfect for stationary playing, on stage, or in a drum circle!



# Bahia Surdos NEW!



Sizes 18" x 16"  
20" x 16"  
22" x 18"

Material Aluminum

Features Counter sunk bolt heads  
Chrome plated hardware  
Replaceable synthetic heads  
8 tuning lugs (18" model)  
10 tuning lugs (20" & 22" models)  
Applying the logo from underneath the head (US patent)

Includes Tuning key

Shorter shells enable to wear in much lower position

1. BAHIA ALUMINUM SURDOS (US patent)

The new MEINL Bahia Aluminum Surdos are made to celebrate Samba-Reggae. Each surdo is cut shorter than its Rio counterpart and typically worn much lower, on a belt. Our three sizes offer two great sounding *fundos* and a higher third-surdo.

2. BAHIA WOOD SURDOS (US patent)

The new MEINL Bahia Wood Surdos celebrate Samba-Reggae music with warm-sounding wooden shells. The three sizes offer the classic high-low *fundos* and a higher pitched third surdo. Each surdo is cut shorter than its Rio counterpart, and typically worn much lower, on a belt.

Thomas Brokop



Inor Sotolongo, France  
Henning and Oliver Hein



Johannes Oster

# Bags & Beaters

1. Sizes 16" x 20"  
18" x 22"  
20" x 24"  
22" x 24"

Material Heavy duty padded nylon

Features Double-slide zipper  
Padded backpack straps  
Carrying grip  
External pocket

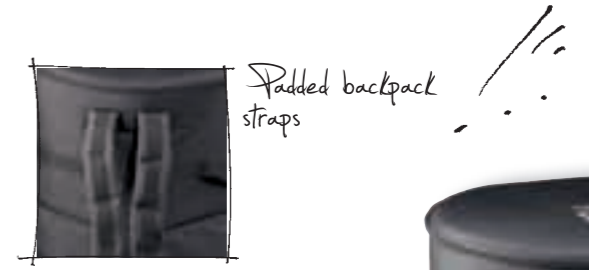

Padded backpack straps



2. SB1 = 15" long, aluminum stick with 2" felt beater  
SB2 = 16" long, wood stick with 2" felt beater  
SB2-D = 16" long, wood stick with two 2" felt beater  
SB3 = 16" long, wood stick with 2 1/2" felt beater  
SB3-D = 16" long, wood stick with two 2 1/2" felt beater  
SB4 = 16" long, wood stick with 2" leather beater  
SB5 = 16" long, wood stick with 3" bushy felt beater



1. PROFESSIONAL SURDO BAGS

The MEINL Surdo Bags are made from heavy duty padded nylon with reinforced stitching and are equipped with a double-slide zipper, padded backpack straps, and a carrying grip.

2. SAMBA BEATERS

MEINL offers a wide assortment of Samba Beaters for Surdos and Repiniques in order to achieve their authentic sounds. All beaters are made from high quality materials to assure comfortable playing.

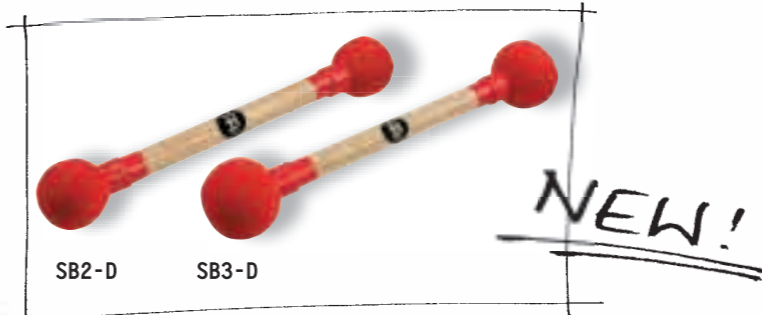

Berenice Viera Kersting

Laura Groh and Marie Schwarz



# Timbales

Professor José J. Cortijo

José J. Cortijo was born in Barcelona in 1958. He has been active as a professor and musician in Germany since 1983. His distinct and particular musical style has landed him gigs with well-known luminaries such as Nina Corti, Chris Thompson, Al Jarreau, Thomas Anders, John Lord, Uwe Ochsenknecht, The Supremes, Conexión Latina, NDR-Big-Band. Jose has also been active on television, radio, and studio recordings and various musicals on stage. As the only Professor for Latin Percussion in Germany, Jose teaches at the National College for Music and Art in Mannheim, and he is a sought-after lector at many workshops and seminars both inside Germany and abroad.



# Professional Series Timbale



- Sizes** 14" & 15"  
**Material** German B8 cymbal bronze  
**Features** Two worked in flanges  
 Cuban style flared out bottom edge  
 Brackets cast from special brass alloy  
 Applying the logo from underneath the head (US patent)  
**Includes** Adjustable cowbell holder  
 Height adjustable tilting double braced tripod stand  
 Accessory pouch  
 L-shaped tuning key  
 Tune Up Oil

BT1415



*Roland Stein*

- Sizes** 14" & 15"  
**Material** Heavy duty padded nylon  
**Features** External pocket for stand and cowbell  
 Padded shoulder strap  
 Carrying grip  
 Padded separator



MTB

- 1. PROFESSIONAL SERIES (US patent)**  
 The Roland Meinl Professional Series Timbales are made from finest German B8 cymbal bronze. They produce a fantastic warm sound with cutting rim shots and enhanced Cascara playing.
- 2. PROFESSIONAL TIMBALE BAG**  
 The MEINL Timbale Bag has two internal compartments (padded separator included) to fit both timbale drums (up to 15") and an outside pocket to fit the stand, cowbells, and sticks.

# Artist Series Timbales

## 1. ARTIST SERIES TIMBALES (Luis Conte) (US patent)

It is with the greatest appreciation and the deepest respect that we honour our friend Luis and his life's work with his MEINL Artist Series Luis Conte Signature Timbales. Perfection in even the smallest details has been achieved in this outstanding instrument. All of the specifications Luis required for his instrument have been consequently realized.



Luis Conte, USA



LC1BRASS

LC1STS

Applying the logo from underneath the head to prevent from wearing off (US patent)

Counter sunk bolt head and bracket cast from special alloy

Extensively hammered shell

Thoughtfully arranged lugs enable an easy way to play the Cascara



The Meinl Artist Series Timbales (Luis Conte) won the MIPA Award in the "Best Percussion Product" category.

- Sizes 14" & 15"
- Material Solid brass or stainless steel
- Features Extensively hammered shells  
Two worked in flanges  
Cuban style flared out bottom edge  
Brackets cast from special brass alloy  
Applying the logo from underneath the head (US patent)
- Includes Adjustable cowbell holder  
Height adjustable tilting double braced tripod stand  
Accessory pouch  
L-shaped tuning key  
Tune Up Oil

## 2. AV1BK

Adjustable cowbell holder

Applying the logo from underneath the head to prevent from wearing off (US patent)



Floatune Tuning System



Amadito Valdes

- Sizes 14" & 15"
- Material Black powder coated steel
- Features Two worked in flanges  
Floatune Tuning System  
Applying the logo from underneath the head (US patent)
- Includes Adjustable cowbell holder  
Height adjustable tilting double braced tripod stand  
Accessory pouch  
L-shaped tuning key  
Tune Up Oil

A tribute to one of the greatest timbaleros ever



Amadito & his daughter Idania

## 3. T11BK

Adjustable cowbell holder



Floatune tuning system

- Sizes 13" & 14"
- Material Black powder coated steel
- Features Two worked in flanges  
Floatune Tuning System  
Applying the logo from underneath the head (US patent)
- Includes Adjustable cowbell holder  
Height adjustable tilting double braced tripod stand  
Accessory pouch  
L-shaped tuning key  
Tune Up Oil

## 2. ARTIST SERIES (Amadito Valdès) (US patent)

The MEINL Artist Series Amadito Valdès Timbales - a tribute to one of the greatest timbaleros ever.

## 3. FLOATUNE SERIES (US patent)

The MEINL Floatune Tuning System used on these timbales works without having to drill into the shell. The result is a voluminous timbale sound with a crisp and warm response, cutting rim shots and a great Cascara sound.

Timbales

# Marathon® Series Timbales

MEINL Marathon® Series Timbales are professionally equipped yet are offered at an affordable price. They are perfect for the working percussionist or to be included in a drum setup.



**Sizes** 14" & 15"  
**Material** Steel  
**Features** Two worked in flanges  
 Heavy duty style brackets  
 Applying the logo from underneath the head (US patent)  
**Includes** Adjustable cowbell holder  
 Height adjustable tilting double braced tripod stand  
 Accessory pouch  
 L-shaped tuning key  
 Tune Up Oil  
**Finishes** Black nickel  
 Brass  
 Chrome

# Headliner® Series Timbale



HT1314CH

**Sizes** 13" & 14"  
**Material** Steel  
**Features** Applying the logo from underneath the head (US patent)  
**Includes** Height adjustable tilting double braced tripod stand  
 Tuning key  
 Wrench  
 Cowbell holder  
**Finish** Chrome

TS5/16  
 TS3/8

TS7/16  
 TS1/2

**Sizes** 5/16"x15", 3/8"x15",  
 7/16"x16 3/4", 1/2"x16 3/4"  
**Material** Hickory Wood



MIT810CH

MDT13CH

**Sizes** 13" drummer timbale  
 8" & 10" mini timbale  
**Material** Steel  
**Feature** Strong mounting clamp  
 Applying the logo from underneath the head (US patent)  
**Includes** L-shaped tuning key  
 Tune Up Oil  
**Finish** Chrome

**1. HEADLINER® SERIES (US patent)**  
 The MEINL Headliner® Series Timbales come in 13" and 14" sizes, are made from chrome plated steel and come with a heavy duty-, height adjustable tilting stand. They provide the classic timbale sound and are the perfect introduction to the joy and passion of timbale playing at an affordable price.

**2. TIMBALE STICKS**  
 The MEINL Timbale Sticks are made out of the finest hand-selected Hickory Wood and are available in four different sizes.

**3. DRUMMER TIMBALE MINI TIMBALE (US patent)**  
 The MEINL Drummer and Mini Timbale provide the characteristic timbale sounds and project enough to cut through any band setting. It is a perfect addition to any percussion- or drum set configuration.



# Frame Drums

The MEINL Frame Drums join the ancient tradition of frame drums from all over the world. Frame drums are perhaps as old as civilization itself. Their associated playing techniques have undergone many adaptations and developments over time, with each culture adding its own particular flavor and style. MEINL Percussion is proud to introduce these carefully crafted drums to deliver the fullest potential of this beloved family of instruments. We use the finest hand selected goat skin for the heads and a wooden frame carefully formed for precision and light weight. Our frame drums feature an internal-lug tuning system, ensuring a dependable performance under a variety of conditions.



Claudia Rapps,  
Germany

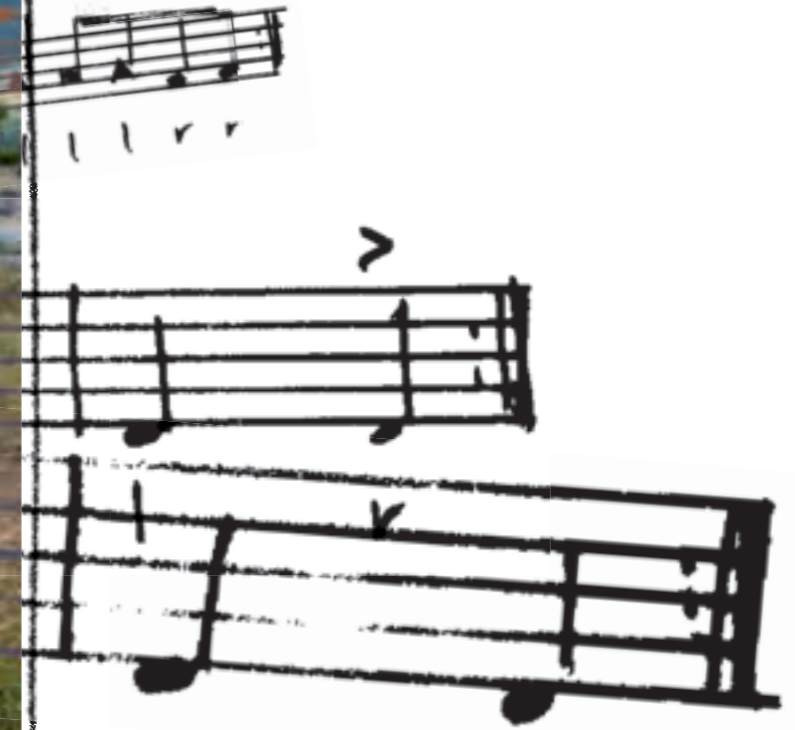

Frame Drums

# Tars



Hand selected goat head



**Sizes** 16", 18", 20", 22"  
2 1/2" deep  
**Materials** Rubber Wood  
(*Hevea brasiliensis* Muell.-Arg.)  
Hand selected goat head

**Feature** Internal lug tuning system  
**Includes** Allen wrench  
**Colour** AB = African Brown  
**Finish** Matte



Sealable filling port allows you to control the amount of steel balls inside

**Sizes** 16" x 2 3/4"  
20" x 2 3/4"  
**Materials** Rubber Wood  
(*Hevea brasiliensis* Muell.-Arg.)  
Hand selected goat head and synthetic head  
**Feature** Sealable filling port allows you to control the amount of steel balls inside  
**Colour** AB = African Brown  
**Finish** Matte

## 1. TARS

The MEINL Tar is a tunable frame drum with a hand selected goatskin head. The tuning lugs are fully recessed within the frame for minimal interference. A scalloped thumb notch and light weight ensures comfortable playing.

## 2. SEA DRUMS

The MEINL Sea Drums create the soothing sounds of the surf, with a great new feature: we sealed the little steel balls between two drum heads, one synthetic and the other natural goatskin. This means you can choose between two completely different timbres within the same drum. A sealable filling port allows you to control the amount of steel balls inside.



Javier Morales, Spain

# Bendirs

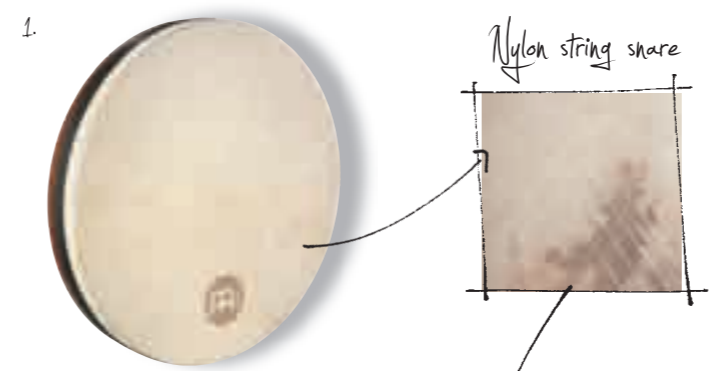

**Size** 16" and 2 1/2" deep  
**Materials** Rubber Wood  
(*Hevea brasiliensis* Muell.-Arg.)  
Hand selected goat head

**Feature** Buzzy effect  
Internal lug tuning system  
**Includes** Allen wrench  
**Colour** AB = African Brown  
**Finish** Matte

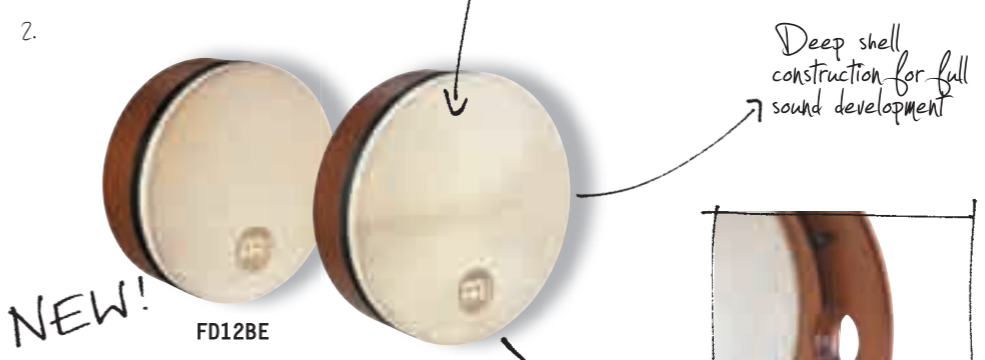

Deep shell construction for full sound development

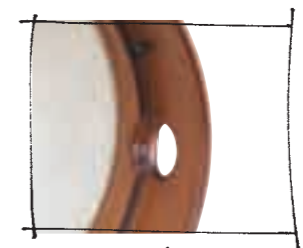

Thumb hole for a good balance and comfortable playing

**Sizes** 12" x 4"  
14" x 4"  
**Materials** Rubber Wood  
(*Hevea brasiliensis* Muell.-Arg.)  
Hand selected goat head  
**Features** Internal tuning system  
Buzzy effect  
Thumb hole for a good balance and comfortable playing  
**Includes** Allen wrench  
**Colour** AB = African Brown  
**Finish** Matte

NEW!

Rüdiger Maul, Germany



## 1. BENDIR

The MEINL Bendir features four thin strings stretched across the inside of the goatskin head, which create the classic Bendir "buzzy" sound. The Bendir is fully tunable and light in weight for long and comfortable playing.

## 2. TRADITIONAL BENDIRS

The new MEINL Traditional Bendirs are made true to the classical North African form. Four adjustable nylon strings spanning the inside of the goatskin head create the characteristic buzzy sound. This fine frame drum is fully tunable, with rich bass tones and crisp taks. The body is deep for full sound development, yet light for comfort and extended play.

# Bodhran

## 1. BODHRAN

The new MEINL Bodhran is made in the classic Celtic style. The drum is held by means of the wooden cross bars and is usually played with a double headed tipper. Internal tuning system ensures you find just the tuning you want.

## 2. TIPPERS

The new MEINL Bodhran Tippers come in five different styles, each with its own characteristic. They range from thin and light, to thick and full bodied. A special tipper with the leather whips was designed by Thórralf Schuh.

NEW!



FD18B0

Size 18" x 4"  
 Materials Rubber Wood (Hevea brasiliensis Muell.-Arg.)  
 Hand selected goat head  
 Features Cross bar  
 Internal tuning system  
 Includes Allen wrench  
 Colour AB = African Brown  
 Finish Matte

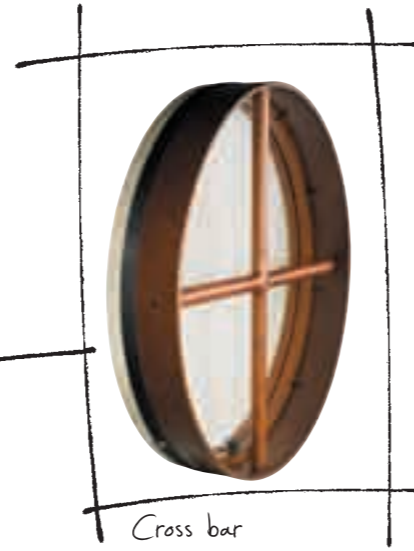

Internal tuning system

NEW!

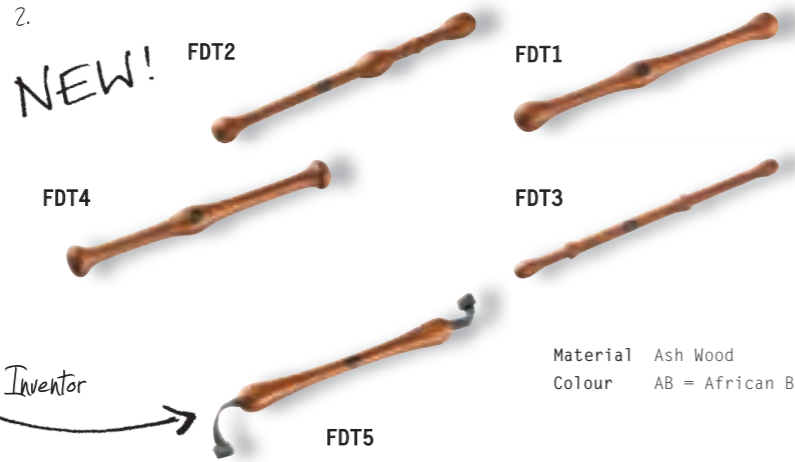

FDT2

FDT1

FDT4

FDT3

FDT5

Material Ash Wood  
 Colour AB = African Brown

Inventor



Thórralf Schuh, Germany



Hanna Gensheimer



Hassawe Ba



Roque Rosales Alarcon



Timo Böttcher



Alexander Greims

## 3.



Sizes 10", 12", 14", 16"  
 Materials Rubber Wood (Hevea brasiliensis Muell.-Arg.)  
 Hand selected goat heads  
 Colour AB = African Brown

## 3. HAND DRUMS

The MEINL Hand Drums are equipped with the finest hand selected goat heads. The scalloped frame guarantees a comfortable grip, which allows the fingers to apply pressure for a 'bending' note. Their light weight yet solid construction makes them perfect for unplugged situations and street percussion.

## 4.



MFDB-16  
 Sizes 16", 18", 20", 22" and 2 1/2" deep  
 Material Heavy duty padded nylon  
 Features Double-slide zipper  
 Shoulder strap  
 Carrying grip

## 4. PROFESSIONAL FRAME DRUM BAGS

The Professional Frame Drum Bags are made from heavy duty padded nylon with reinforced stitching. They protect your instruments and provide hassle free transportation.

## 5.



MFDB-12BE  
 MFDB-14BE  
 Sizes 12" x 4"  
 14" x 4"  
 Material Heavy duty padded nylon  
 Features Double-slide zipper  
 Shoulder strap  
 Carrying grip

## 5. PROFESSIONAL BENDIR BAGS

The Professional Traditional Bendir Bags are ideal for transporting your drum safely to your gig and back again. Made from heavy-duty padded nylon with reinforced stitching, they fully protect the instrument. Handy grips and shoulder strap make it easy to carry.

## 6.



MFDB-18B0  
 Size 18" x 4"  
 Material Heavy duty padded nylon  
 Features Double-slide zipper  
 Shoulder strap  
 Carrying grip

## 6. PROFESSIONAL BODHRAN BAG

The Professional Bodhran Bag protects your drum and provides hassle free transportation.



Holger Mertin, Germany

# Wood Tambourines

MEINL's Wood Tambourines are made from a sturdy frame with jingles available in different materials, resulting in various sound possibilities. Their ergonomically shaped handle and light weight enable energetic playing.

## 1. SUPER-DRY STUDIO TAMBOURINES

The new MEINL Super-Dry Studio Tambourines feature hand-hammered brass jingles on a wooden frame. They are available with one or two rows of jingles for your desired sound. We make them light and comfortable, for prolonged and precise playing.

## 2. HEADED SUPER-DRY STUDIO TAMBOURINES

The new MEINL Headed Super-Dry Studio Tambourines feature hand-hammered brass jingles on a wooden frame with a hand-selected goatskin head. Available with one or two rows of jingles, they are light, comfortable and have a great sound.



STA1B-BK

STA2B-BK

Size 10"  
Materials Hand-hammered brass  
Wooden frame  
Features Hand-hammered triangularly jingles for extra dry sound  
1 row and 2 row version  
Colour BK = Black



STAH1B-BK

STAH2B-BK

Size 10"  
Materials Hand-hammered brass  
Wooden frame  
Feature Hand-hammered triangularly jingles for extra dry sound  
1 row and 2 row version  
Colour BK = Black



Arnold Riedhammer, Germany

## 3. TA1M-SNT



TA2M-SNT

Size 10"  
Materials Nickelsilver plated steel meets solid brass  
Wooden frame  
Features Dual-alloy jingles  
1 row and 2 row version  
Colour SNT = Super Natural

## 5. TA1AB



TA2AB

Size 10"  
Materials Nickelsilver plated steel  
Wooden frame  
Feature 1 row and 2 row version  
Colour AB = African Brown

## 7. TA1A-AB



TA2A-AB

Size 10"  
Materials Aluminum  
Wooden frame  
Feature 1 row and 2 row version  
Colour AB = African Brown

## 9. TA1B-AB



TA2B-AB

Size 10"  
Materials Solid brass  
Wooden frame  
Feature 1 row and 2 row version  
Colour AB = African Brown

## 4. TAH2M-SNT



TAH1M-SNT

Size 10"  
Materials Nickelsilver plated steel meets solid brass  
Hand selected goat heads  
Wooden frame  
Feature Dual-alloy jingles  
1 row and 2 row version  
Colour SNT = Super Natural

## 6. TAH1AB



TAH1AB

Size 10"  
Materials Nickelsilver plated steel  
Hand selected goat heads  
Wooden frame  
Feature 1 row and 2 row version  
Colour AB = African Brown

## 8. TAH1A-AB



TAH2A-AB

Size 10"  
Materials Aluminum  
Hand selected goat heads  
Wooden frame  
Feature 1 row and 2 row version  
Colour AB = African Brown

## 10. TAH1B-AB



TAH2B-AB

Size 10"  
Materials Solid brass  
Hand selected goat heads  
Wooden frame  
Feature 1 row and 2 row version  
Colour AB = African Brown

## 3. RECORDING-COMBO WOOD TAMBOURINES

The MEINL Recording-Combo Wood Tambourines create a whole new sound colour. It is both dry and bright. It offers a sophisticated and highly adaptable sound, with both projection and sustain.

## 4. HEADED RECORDING-COMBO WOOD TAMBOURINES

The MEINL Headed Recording-Combo Wood Tambourines features a hand selected goatskin head for full and warm tones, whether played with stick or hand.

## 5. WOOD TAMBOURINES, STEEL JINGLES

Featuring 1 or 2 row versions. The MEINL Wood Tambourines with nickel-silver plated steel jingles produce a bright sound that projects well.

## 6. HEADED WOOD TAMBOURINES, STEEL JINGLES

With steel jingles and the finest hand selected goat heads firmly attached. This instrument delivers a subtle and gentle tone when played by hand and a voluminous and rich sound.

## 7. WOOD TAMBOURINES, ALUMINUM JINGLES

Featuring 1 or 2 row versions, the MEINL Wood Tambourines with aluminum jingles deliver a very soft and harmonic sound.

## 8. HEADED WOOD TAMBOURINES, ALUMINUM JINGLES

With aluminum jingles and fine hand selected goat heads firmly attached to the shell, these tambourines have an extra-fine, bright, and sweet sound when played by hand or stick.

## 9. WOOD TAMBOURINES, BRASS JINGLES

Featuring 1 or 2 row versions. Solid brass jingles deliver a distinctively warm, and cutting sound.

## 10. HEADED WOOD TAMBOURINES, BRASS JINGLES

These tambourines deliver a distinctively warm and cutting sound when played by hand or stick. Featuring 1 or 2 row versions.

# ABS Tambourines

MEINL Hand and set-up Tambourines (design protected by a utility model) have a distinct design advantage due to the construction of the ABS frame. Unlike other tambourines, MEINL's utilizes several different parts in the frame which are assembled into a type of "sandwich." This results in unsurpassed durability.

## 1. TAMBOURINES, STEEL JINGLES

These ergonomically shaped tambourines are available as hand held or mountable versions. The durable ABS frame allows hard hitting and energetic hand playing. Nickel-silver plated steel jingles produce a bright sound that projects well.

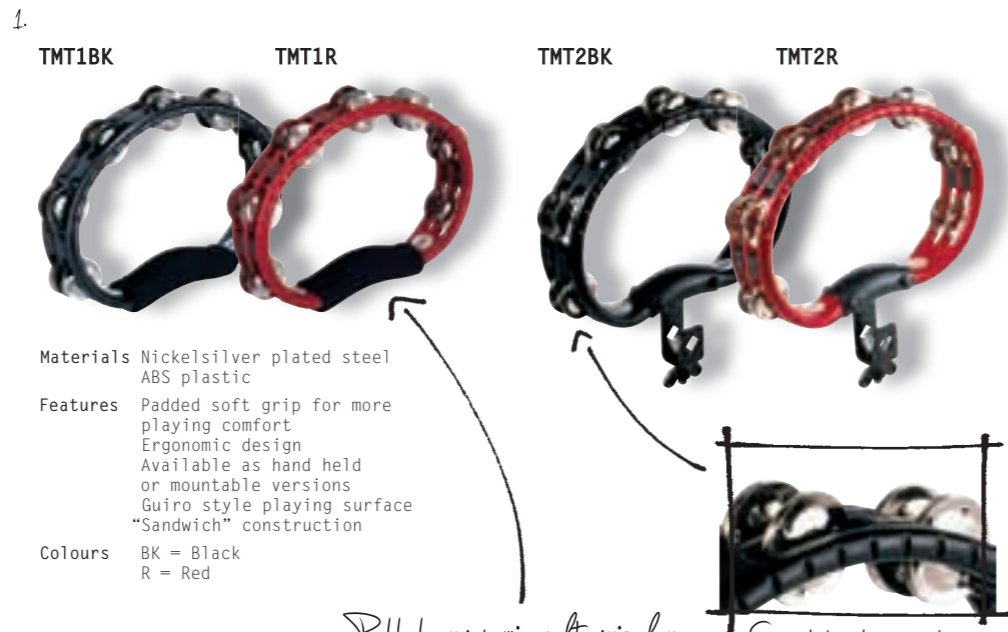

**Materials** Nickelsilver plated steel  
ABS plastic  
**Features** Padded soft grip for more playing comfort  
Ergonomic design  
Available as hand held or mountable versions  
Guiro style playing surface  
"Sandwich" construction  
**Colours** BK = Black  
R = Red

*Padded ergonomic soft grip for more playing comfort*

*Steel jingles produce a bright sound that projects well*

## 2. RECORDING-COMBO ABS TAMBOURINES

The new MEINL Recording-Combo ABS Tambourines feature our popular mixed jingles, where nickel-silver plated steel meets solid brass, for a unique and pleasing sound. Our special ABS "sandwich" construction makes them nearly indestructible.

## 3. TAMBOURINES, ALUMINUM JINGLES

The hand held versions are extremely light weight for extensive and energetic playing. The mountable version is built to resist hard hitting.



*Mixed jingles*



**Materials** Solid brass  
ABS plastic  
**Features** Padded soft grip for more playing comfort  
Ergonomic design  
Available as hand held or mountable versions  
Guiro style playing surface  
"Sandwich" construction  
**Colours** B = Blue  
WH = White (hand held only)

*A "Guiro" kind of sound can also be produced by scraping the ribbed edge of the frame*

*Easy mountable*

*Aluminum jingles produce a very soft and harmonic tone*

*Solid brass jingles produce a warm, yet cutting sound*



**Materials** Solid brass  
ABS plastic  
**Features** Padded soft grip for more playing comfort  
Ergonomic design  
Available as hand held or mountable versions  
Guiro style playing surface  
"Sandwich" construction  
**Colour** BK = Black

*Rubber pads against scratching*

*Padded surface against rattling*

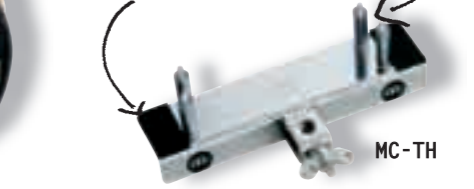

**Material** Chrome plated steel  
**Features** Rubber pads against scratching  
Padded surface against rattling

## 4. TAMBOURINES, BRASS JINGLES

The durable ABS frame allows hard hitting and energetic hand playing. They deliver a very warm, yet cutting sound.

## 5. TAMBOURINE HOLDER

The tambourine holder converts a MEINL Hand Held Tambourine into a set-up tambourine. It holds it in place and is made to resist even the hardest hits.

## 6. HIHAT TAMBOURINE

Steel jingles provide a bright, cutting sound. A sturdy rubberized striking ring ensures a clean response and a long life. An easy-access wing nut allows quick set-up, adjustment, or removal, all independent from your cymbals.

## 6. THH1BK



**Size** 5"  
**Material** Steel  
**Features** Plated steel jingles  
Rubber padded surface  
**Colour** BK = Black

## 7. JINGLE STICKS

The MEINL Jingle Sticks create many interesting sound possibilities.

## 8. HEADLINER® SERIES JINGLE STICKS

The MEINL Headliner® Series Jingle Sticks are a nice and affordable alternative to a tambourine. Nice sound effects are also achieved when used as a stick on a drum.

## 7. JG1A-B



## JG1BK

## 8. HJS1BK



## HJS1R

**Materials** Nickelsilver plated steel  
ABS plastic  
**Colours** BK = Black  
R = Red

*Guiro style playing surface*

## JG1B-BK



## JG1R

**Jingles** JG1 = Nickelsilver plated steel  
JG1A = Aluminum  
JG1B = Solid brass  
**Features** Padded grip  
Guiro style playing surface

*Riaan Van Rensburg, Netherlands*



*Tambourines, Jingle Sticks*

ABS TAMBOURINES

HIHAT TAMBOURINE, JINGLE STICKS, HEADLINER® SERIES JINGLE STICKS



# THE BLUE DEVILS



[www.bluedevils.org](http://www.bluedevils.org)

*The Blue Devils*



[meinlpercussion.com](http://meinlpercussion.com)

# Realplayer Steelbells

MEINL's Realplayer Steelbells are hand made using a special steel alloy. The parts are welded together in a continuous seam and sealed with a protective coating.

## 1. ARTIST SERIES RUSS MILLER (patent pending)

The Russ Miller "Multi-Bell" enables multiple tones and is a breakthrough in versatility. You can adjust the amount of ring to your desired level with just a turn of a knob. This innovation brings out the most in a cowbell!

1.



Adjustable interior dampening mechanism (patent pending)

RM80B

Size 8" big mouth  
Material Special steel alloy  
Features Adjustable interior dampening mechanism (patent pending)  
Hand-hammered  
Finish Hand-brushed black



Russ Miller, USA

## 2. HAND-HAMMERED MODELS

The strong fundamental tone of these Steelbells make them a unique alternative to all other bells on the market. Each Steelbell has its own character.

2.

Extra thick welded joint for long durability



STB625HH-G



STB80BHH-G



STB625HH-C



STB80BHH-C

## 3. ARTIST SERIES KENNY ARONOFF

Kenny Aronoff says: "My Artist Series Signature Cowbells are the ultimate drummer's bells. Playing live they cut through and have very nice tones. Their recording characteristics are outstanding, too."

3.



KA625



KA80S

Kenny Aronoff

Hand-hammered

Sizes 6 1/4" 8" big mouth  
Material Special steel alloy  
Feature Hand hammered  
Finishes Hand brushed gold Hand brushed copper

## 4. CHROME FINISH MODELS

These highly polished chrome finished models are not only visually bright, they also satisfy all of the sonic requirements for South American rhythms.

4.



STB45L-CH



STB80S-CH



STB625-CH



STB80B-CH

Extra thick welded joint for long durability

Special steel alloy for a bright sound

Sizes 4 1/2" low pitch 6 1/4" 8" small mouth 8" big mouth  
Material Special steel alloy  
Feature Bright sound  
Finish High polished chrome

## 5. STEEL FINISH MODELS

The pitches of these Steelbells form a diatonic scale which makes it easy to use multiple bell combinations in any musical setting.

5.



STB45L



STB625



STB45M



STB80S



STB45H



STB80B

Easy mountable

Hand brushed steel finish !!!

Sizes 4 1/2" low pitch 4 1/2" medium pitch 4 1/2" high pitch 6 1/4" 8" small mouth 8" big mouth  
Material Special steel alloy  
Feature Tonally matched  
Finish Hand brushed steel



Matthias "Maze" Meusel, Germany



Kenny Aronoff USA



# Cowbells & Blocks

## 1. BLACK FINISH MODELS

The MEINL Black Finish Models cowbells have been especially designed to meet all of the requirements of today's modern percussionists and drum set players.

## 2. TRIPLE BELL

The three pitch-matched bells combined in one unit, offering modern percussionist a variety of new playing options.

## 3. COWBELL BEATERS

MEINL offers a regular and professional cowbell beater for more sound options.

## 4. HAND MODELS

These Bongo Bells easily cut through any high volume environment and are comfortable to hold. They are perfect for a classic bongo pattern.

## 5. HANDMATE

The MEINL Handmate is a professional cowbell beater which can be mounted in a set-up. This allows hitting the cowbell by hand while playing another instrument.

## 6. COWBELL BASS DRUM HOLDER

The MEINL Cowbell Holder attaches firmly to the bass drum hoop. Rubber pads prevent scratches on the hoop.



**SL475-BK**  
**SL525-BK**  
**SL850-BK**

Sizes 4 3/4"  
 5 1/4"  
 8 1/2"

Material Special steel alloy  
 Feature Muffled sound  
 Finish Black powder coated steel



**SLTRI-BK**

Sizes 2 1/2"  
 3 1/2"  
 5"

Material Special steel alloy  
 Feature Muffled sound  
 Finish Black powder coated steel

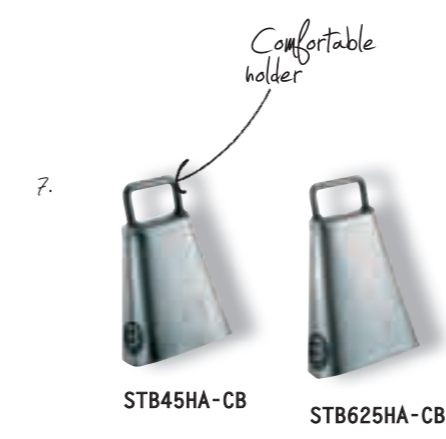

**STB45HA-CB**  
**STB625HA-CB**

Sizes 4 1/2"  
 6 1/4"

Material Special steel alloy  
 Feature Comfortable holder  
 Finish Hand brushed steel



**STB45HA-ALU**  
**STB625HA-ALU**

Sizes 4 1/2"  
 6 1/4"

Material Aluminum  
 Features Light weight construction  
 Comfortable rectangular grip

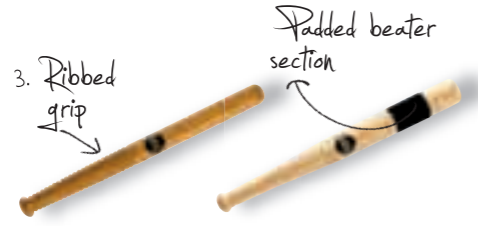

**COW1**  
**COW2**

Material Rubber Wood  
 (Hevea brasiliensis Muell.-Arg.)  
 Features Ribbed grip  
 Padded beater section

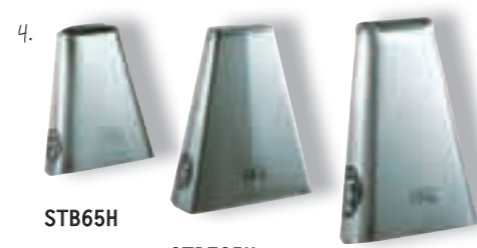

**STB65H**  
**STB785H**  
**STB815H**

Sizes 6.5"  
 7.85"  
 8.15"

Material Special steel alloy  
 Finish Hand brushed steel



**MPE1BK**

Material PE  
 Features High pitched sound  
 Durability

Includes Mounting Clamp  
 Colour BK = Black



**MPE2R**

Material PE  
 Features Low pitched sound  
 Durability

Includes Mounting Clamp  
 Colour R = Red

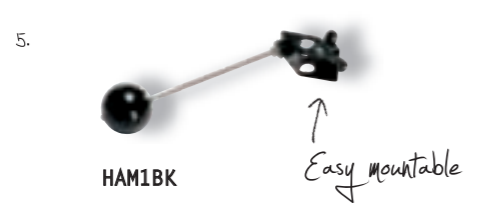

**HAM1BK**

Material Steel construction with a wooden ball  
 Feature Fully adjustable

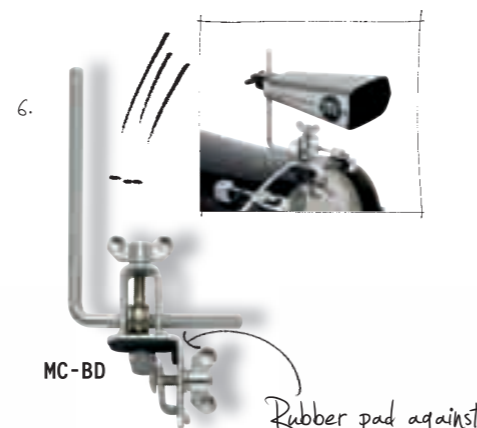

**MC-BD**

Material Chrome plated steel  
 Features Fully adjustable  
 Rubber pads against scratching

Includes L-shaped rod

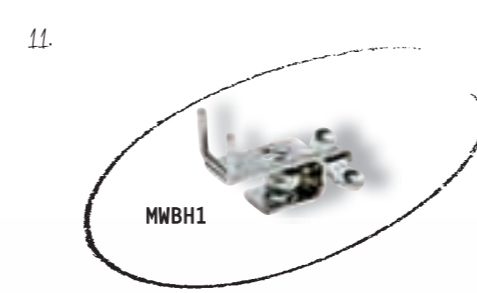

**MWB1**

Material Chrome plated steel



**MWB2BK**  
**MWB1BK**

Sizes Small, large  
 Material Rubber Wood  
 (Hevea brasiliensis Muell.-Arg.)  
 Feature Rounded playing surface  
 Includes Wooden beater  
 Colour BK = Black  
 Finish Matte

## 7. HANDHELD MODELS

The unique feature of the MEINL Handheld Models is a wide and comfortable grip. Ideal for street percussion.

## 8. HANDHELD MODELS, ALUMINUM

Another true MEINL innovation! They are the perfect handheld bells for Samba music due to their light weight and comfortable grip which keeps the player from tiring, allowing for energetic playing.

## 9. PERCUSSION BLOCK, HIGH PITCH

The MEINL Percussion Block is made to withstand even the hardest hitting players. It delivers a cutting high pitched sound.

## 10. PERCUSSION BLOCK, LOW PITCH

This MEINL Percussion Block delivers a low pitched sound and is easily mounted on any conventional L-rod.

## 11. WOOD BLOCK HOLDER

A special holder is available to include the MEINL Wood Blocks into any drum- or percussion set-up. It can be fixed to any common L-rod.

## 12. WOOD BLOCKS

The two versions of the MEINL Wood Blocks are tonally matched, highly durable and produce a voluminous sound with wood accents.

Laura Craciunean



Leonnie and Dagmar Knye



Kai Büngener

Steffen Walter



Annika Meinhard



# Cowbells & Blocks



# Chimes

MEINL Chimes provide great tonal effect and are available in a wide assortment of sounds. All MEINL Chimes are made from a premium anodized aluminum alloy, and a well balanced wooden bar. A durable nylon cord is used to hang them securely.



Luis Conte, USA

Premium anodized aluminum alloy

1. **LC60HF**

All bars are attached through a nylon cord

f c c t e

Size	60 bars, double row
Material	Silver anodized aluminum alloy
Feature	High frequency chime
Includes	Holder Striker

1. **ARTIST SERIES (Luis Conte)**  
 "I wanted a wide spectrum!" comments Luis Conte.  
 "The shorter bars deliver great high pitched sounds. I can get a full and bright chime sound from the medium and low pitched bars. They sound perfect especially in the studio."

2. **CHIMES, 66 BARS**  
 The 66 bar chimes produce a rich and full sound. They cut through any band setting.

3. **CHIMES, 36 BARS**  
 With bars made from hand polished aluminum, these chimes produce a sound that is clear, bright, and rich in volume and expression.

4. **CHIMES, 33 BARS**  
 The 33 bar chimes produce a very bright sound with a pronounced upper overtone spectrum. They are perfect for all live situations.

5. **ROCK CHIMES, 33 BARS**  
 The bars of MEINL Rock Chimes are thicker for a richer and more voluminous sound.

6. **CHIMES, 27 BARS**  
 The 27 bar chimes produce a full sound with a wide tonal spectrum. Ideal for smaller stages and club scenes.

2. **CH66HF**

Size	66 bars, double row
Material	Gold anodized aluminum alloy
Feature	High frequency chime
Includes	Holder Striker



3. **CH36**

Comes with striker

Size	36 bars, single row
Material	Silver anodized aluminum alloy
Includes	Holder Striker

4. **CH33HF**

High frequency chime

Size	33 bars, single row
Material	Gold anodized aluminum alloy
Feature	High frequency chime
Includes	Holder Striker

5. **CH33HF-R**

Size	33 bars, single row
Material	Gold anodized aluminum alloy
Feature	High frequency chime
Includes	Holder Striker

6. **CH27**

Size	27 bars, single row
Material	Gold anodized aluminum alloy

7. **CH27ST**

Size	27 bars, single row
Material	Gold anodized aluminum alloy

8. **CH12**

Size	12 bars, single row
Material	Gold anodized aluminum alloy

7. **STUDIO CHIMES, 27 BARS**  
 The Studio Chimes feature slightly thinner bars for a full, rich and delicate sound.

8. **CHIMES, 12 BARS**  
 The 12 bar chimes produce a beautiful, high pitched sound. Not too obtrusive, ideal for tasteful chime accents.

9. **HEADLINER® SERIES CHIMES**  
 The MEINL Headliner® Series Chimes are a great and affordable addition to any percussion set-up! They are made from high quality materials and produce a full and warm chime sound.

10. **CHIMES HOLDERS**  
 These two differently sized MEINL holders comfortably place the chimes within a drum or percussion set-up.

11. **PROFESSIONAL CHIMES BAG**  
 The MEINL Chimes Bag fits all common chime models and is the perfect solution for transporting these valuable precision instruments. Inner velcro straps hold the instrument in place while two internal pockets secure them.

9. **HCH1R**

Size	27 bars
Material	Silver anodized aluminum alloy

10. **MC-CHL**  
**MC-CH**

Sizes	Regular Large
Material	Chrome plated steel
Features	Knurled surface Foam washer

11. **MCHB**

Material	Heavy duty padded nylon
Features	Stores up to 2 chimes Carrying grip Inner velcro straps 2 internal pockets



# Hand Percussion

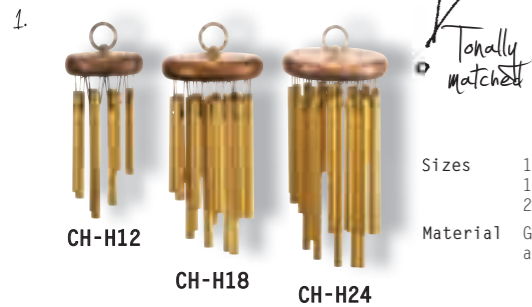

Tonally matched

Sizes  
12 bars  
18 bars  
24 bars

Material  
Gold anodized aluminum alloy

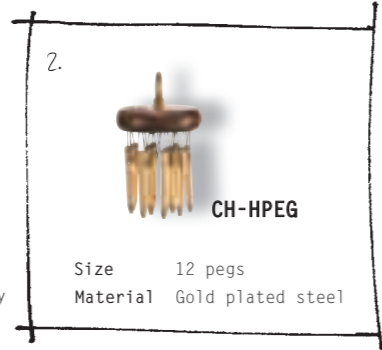

Size 12 pegs  
Material Gold plated steel

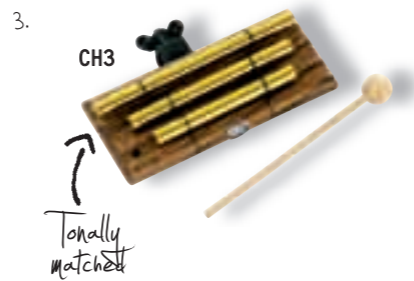

Material Gold anodized aluminum alloy  
Feature Mountable on all common L-rods  
Includes Wooden beater Holder

**1. HAND CHIMES**  
The three differently sized models of hand chimes are tonally matched. They can easily be played by hand only and still produce a full and rich sound.

**2. PEG CHIMES**  
The Peg Chimes are extremely high pitched. They are perfect for special accents.

**3. TRI TONE CHIMES**  
The three free-floating bars create a very long sustain and are tonally matched.

**4. TRIANGLES**  
The solid brass triangles produce a nice sounding soft tone with a controlled sonic spectrum.

**5. TRIANGLE HOLDER**  
The MEINL Triangle Holder is a simple but effective way to place the triangle in the percussion set-up.

**6. HANGING FINGER CYMBALS**  
Strung on a durable cord and made from a special bronze alloy, 14 unique finger cymbals produce a shimmering chorus effect.

**7. FINGER CYMBALS**  
Measuring 2 3/8" in diameter, they are easy to hold and comfortable to play.

**8. PROFESSIONAL FINGER CYMBALS**  
Made from a special bronze alloy and attached with a durable cord, these professional finger cymbals are relatively heavy in weight producing a high pitched and cutting, pure ping sound.

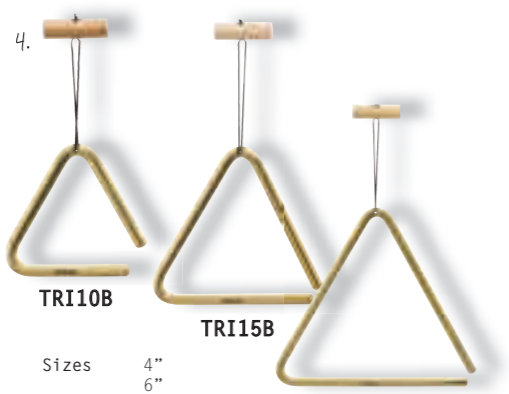

Sizes  
4"  
6"  
8"

Material Solid brass  
Includes Wooden holder with braided nylon cord  
Metal beater

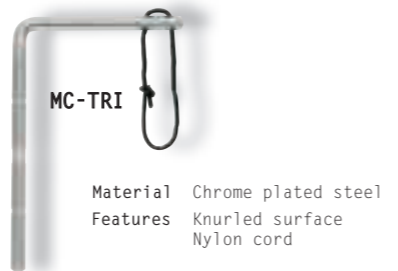

Material Chrome plated steel  
Features Knurled surface  
Nylon cord



Size 2 5/8" diameter  
Material Special bronze alloy  
Features Identical, high pitched sound  
Durable cord



Size 2 3/8" diameter  
Material Special bronze alloy  
Features Durable cord  
Shimmering sound



Size 2 3/8" diameter  
Material Special bronze alloy  
Features Identical in pitch  
Durable rubber band connection



Materials Solid brass bells  
Wooden handle  
Includes Striker



Material Solid brass bells  
Feature Adjustable metal stand  
Includes Striker



Sizes Small - g<sup>b</sup>c<sup>b</sup>f<sup>b</sup>c<sup>b</sup>  
Medium - a<sup>b</sup>c<sup>b</sup>a<sup>b</sup>A<sup>b</sup>f<sup>b</sup>e<sup>b</sup>b<sup>b</sup>

Materials Chrome plated steel  
Rubber Wood  
(*Hevea brasiliensis* Mue11.-Arg.)

Feature Ergonomic shape

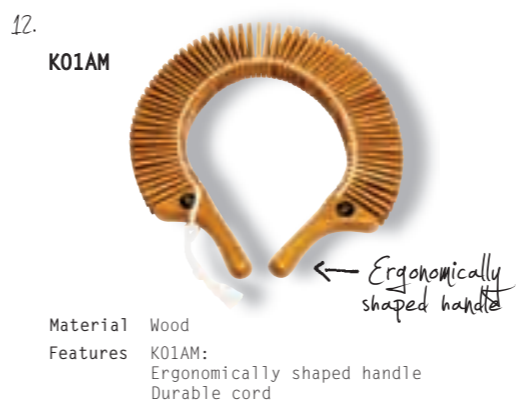

Material Wood  
Features K01AM:  
Ergonomically shaped handle  
Durable cord



Features K02AM/BK:  
Ergonomically designed handgrips  
Wide, stable binding strap in real leather

Colours AM = Amber  
AM/BK = Amber/Black

**9. HAND HELD BELL TREE**  
The new MEINL Bell Tree (Hand Held Bell Tree) has a cascade of 14 solid brass bells securely mounted on a wooden handle. Depending on how you choose to play it, the Bell Tree can be a melodic, rhythmic, or chromatic instrument.

**10. STAND ALONE BELL TREE**  
The new MEINL Bell Tree has 27 solid brass bells mounted on a sturdy metal stand. The extra large chromatic cascade of bells may also be played rhythmically or melodically.

**11. KALIMBAS**  
The new MEINL Kalimbas are great sounding melodic instruments in a compact size! Solid construction, plated steel keys and an ergonomic shape makes these kalimbas dependable musical tools. The sound is pure joy, and a great addition to any percussion kit.

**12. KOKIRIKO**  
The Kokiriko originated in Japan as a sound effect instrument. It produces a rattling effect which can be an almost silent rustling to an extremely loud catter.



NEW!

NEW!

NEW!

NEW!

# Shakers

Bill Saragosa  
inventor of the Spark Shakers



Size Medium  
Materials Shaker: Coated steel  
Pellets: Coated steel  
Finish Black nickel

Circular motion enables a unique rattling sound

**1. SPARK SHAKER**  
The sparkling, chirping, splashing tones readily mix with almost any musical flavour. The pod-like shape fits easily into the hand and may be manipulated for many interesting effects. Spark Shakers may be played in pairs, or in combination with other shakers for even more variations.

**2. SPIN SPARK SHAKER**  
The MEINL Spin Spark Shaker is equipped with a screw-mounted disc that adjusts and amplifies the characteristics of the fundamental pitch. When the disc is tight, the pitch is highest; and it deepens as the disc is loosened. There is a distinctively pleasant supplemental timbre.

**3. HEADED SPARK SHAKER**  
One side of the MEINL Headed Spark Shaker is a drum head! Premium goatskin and a steel shell provide a rattling combination of crisp warm tones and a bright metal timbre.



Size Medium  
Materials Shaker: Coated steel  
Pellets: Coated steel  
Goat head  
Finish Black nickel



Screw-mounted disc enables a tunable pitch

Size Medium  
Materials Shaker: Coated steel  
Pellets: Coated steel  
Finish Black nickel



Side view

Sensational effects are produced when combined with another Spark Shaker

**NEW!**

High pitch

Low pitch

SH22

Material Steel  
Features Comes in a set of two  
Wildly variable pitch response  
Finish Black nickel

**4. CLAMSHELL SPARK SHAKERS**  
Two great new Shakers from Bill Saragosa! The Clamshell Spark Shakers have a single solid weld holding the two halves of the shell together like a hinge. When you squeeze the two halves together, you get a wildly variable pitch response. It comes in two pitches, for high-low combinations.

**5. ALUMINUM SHAKERS, OCTAGONAL**  
MEINL's Octagonal Aluminum Shakers come in two different sizes. Both have a broad dynamic range with lots of volume.

**6. ALUMINUM JINGLE SHAKER**  
The MEINL Aluminum Jingle Shaker (designed by Juan Carlos Melian) has two pairs of steel jingles which are attached in one row to an octagonal aluminum shaker.

**5. SH8BK SH88BK**

Size Small  
Medium  
Material Aluminum  
Colour BK = Black



Size Medium  
Materials Shaker: Aluminum  
Jingles: Steel  
Colour BK = Black

By tilting the shaker 90° to the front the jingles start to click on the beat

Jenny Flamann



Marlene Schneider and Eva Maria Piernikorz

Katharina Wernecke and Florian Bauer

Gert Schultheiß

Andreas Weigand

# Shakers

## 1. STUDIO SHAKER

MEINL's Studio Shaker was designed to meet all the requirements necessary in today's session world. It delivers a very tasteful and delicate shaker sound with a warm overall tone and a very well balanced frequency spectrum.

## 2. FIBERGLASS SHAKERS

These MEINL Shakers are made from premium fiberglass for more durability and better sound quality. They are light weight and very comfortable to play.

## 3. ALUMINUM SHAKERS, ROUND

The MEINL Round Aluminum Shakers were designed to cut through loud live music. Available are two different versions.

## 4. SHAKER HOLDER

The MEINL Shaker Holder (designed by Jen Lowe) firmly attaches to any common rod. With its length adjustable specially shaped claws it holds any size shaker in a comfortable position for quick reach.

## 5. WOOD SHAKERS

Made from a combination of selected woods, these new MEINL Wood Shakers offer a nice array of alternative sounds.

## 6. RAWHIDE SHAKER

The MEINL Rawhide Shaker combines two different materials into one unique instrument. It produces very experimental sounds and works perfectly in modern music productions.

## 7. U.F.O. SHAKER

The MEINL U.F.O. Shaker produces an extreme mellow and smooth sound and less attack.



SH10-L-BK  
Size Large  
Material Plastic  
Colour BK = Black

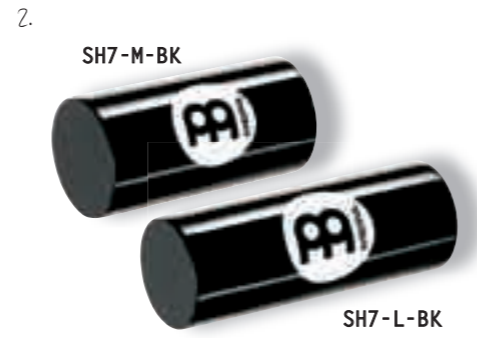

SH7-M-BK  
SH7-L-BK  
Sizes Medium Large  
Material Premium fiberglass  
Colour BK = Black



SH9-L-S  
SH99-L-S  
Size Large  
Material Anodized aluminum  
Features Available as a single, or double shaker  
Colour S = Silver

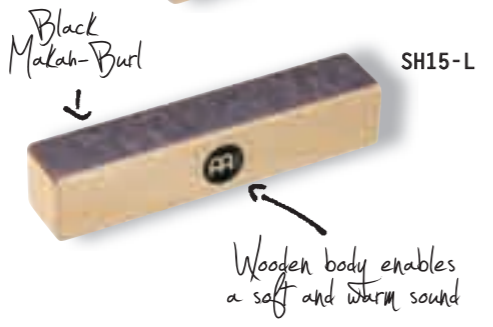
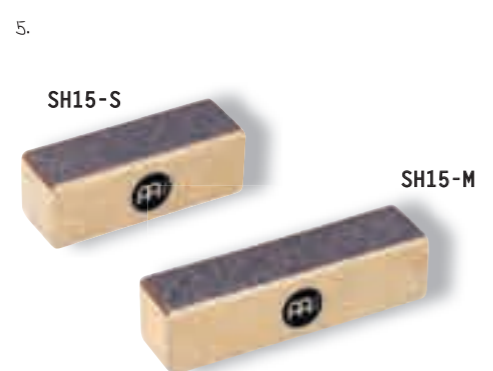

SH15-S  
SH15-M  
SH15-L  
Sizes Small Medium Large  
Materials Rubber Wood (Hevea brasiliensis Muell.-Arg.)  
Top and Bottom: Black Makah-Burl

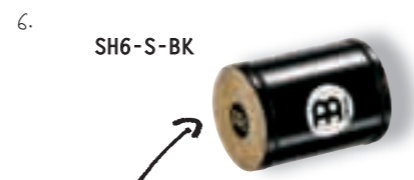
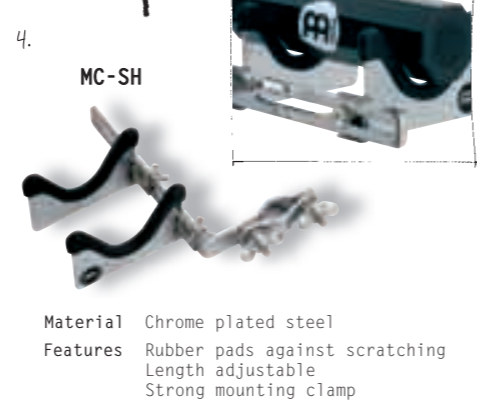

SH6-S-BK  
Size Small  
Materials Plastic with natural rawhide side caps  
Colour BK = Black



SH21BK  
Size Medium  
Material Plastic  
Colour BK = Black



SH20BK  
Size Medium  
Materials Wooden body and plastic chamber  
Colour BK = Black

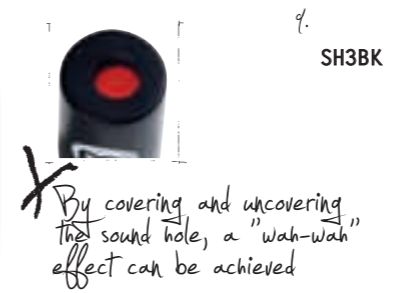

SH3BK  
Size Medium  
Material Plastic  
Colour BK = Black



## 8. WAKAH SHAKER

The MEINL Wakah Shaker is another unique and innovative instrument, offering yet another voice to a percussionist's range of sounds. The shaker has two chambers which are separated by a plastic membrane.

## 9. LOOP SHAKER (US patent)

The MEINL Loop Shaker has a crackling bright sound with many dynamics, and is easy to control. It is very responsive to hand pressure and movement, giving it a soft or loud voice as needed.

## 10. ARTIST SERIES (Luis Conte)

The three versions have been designed according to master percussionist Luis Conte's exact requirements. "My shaker sound is as smooth as silk" is how Luis described their sound.

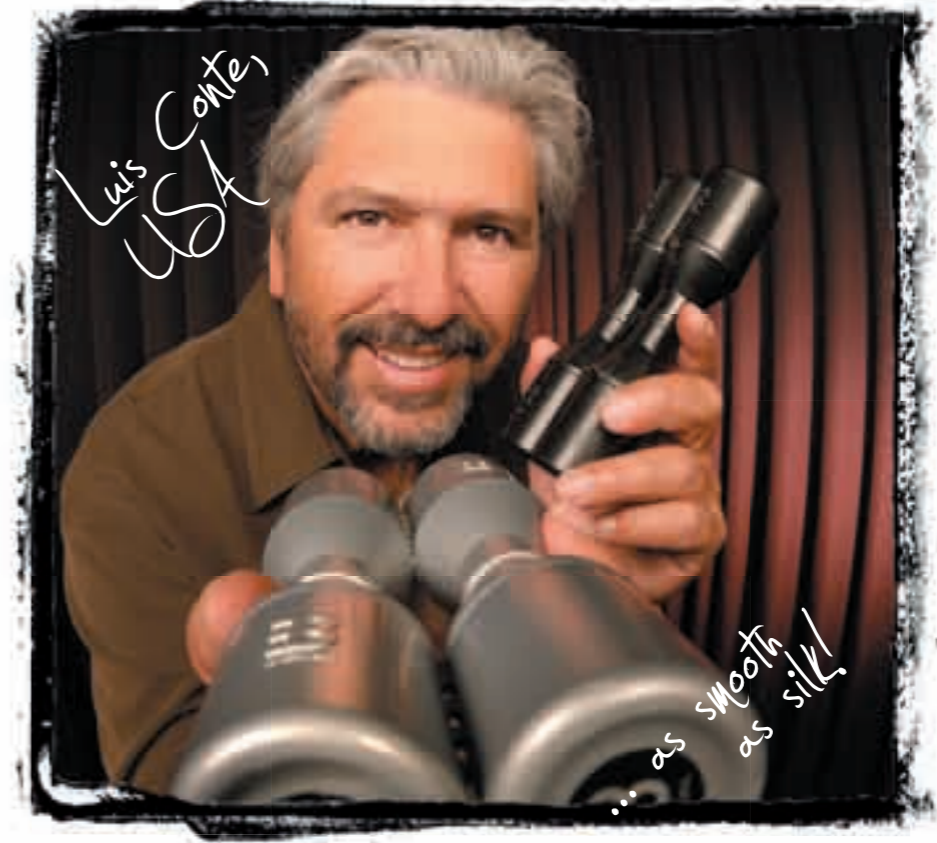

SH4BK  
Size Medium  
Material Plastic  
Feature Two individual shakers connected as one instrument

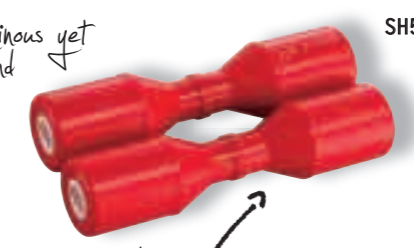

SH5R  
Very subtle and smooth tone  
Colours Live Shaker: BK = Black  
Studio Shaker: R = Red  
Stadium Shaker: GR = Grey

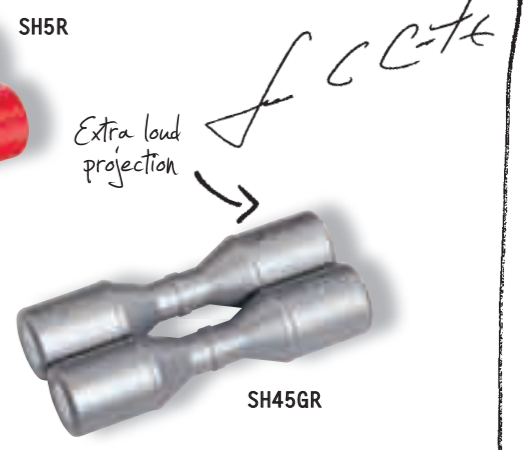

# Hand Percussion

## 1. PLASTIC EGG SHAKERS

The MEINL Plastic Egg Shakers are preferred due to their smooth and crystal clear sound. These have applications in practically any musical setting.

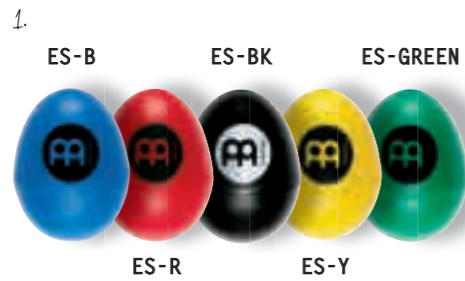

Material Plastic  
Colours B = Blue  
BK = Black  
GREEN = Green  
R = Red  
Y = Yellow

## 2. WOOD EGG SHAKER

The MEINL Wood Egg Shaker is turned from wood and deliver a soft yet rich sound. It's perfect in situations which require clearly defined accents.

## 2.



Size Jumbo  
Material Wood  
Colour BK = Black

## 3. DOUBLE SHAKER

The MEINL Double Shaker is woven by hand. It offers two different sounds in one instrument.

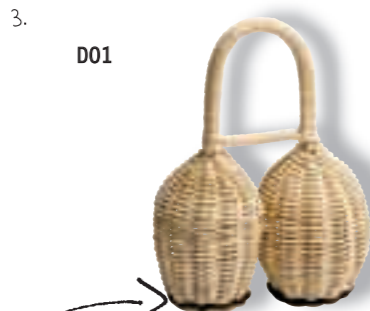

D01

Materials Rattan with coconut bottom

Coconut bottom for increased projection

## 4. CAXIXIS/GANZA

The MEINL Caxixis/Ganza are woven by hand with a coconut bottom. Their sound is crystal clear, high pitched with a great projection.



CAX1

CAX2

CAX3

GA2

## 5. WOOD MARACAS

The traditional MEINL Wood Maracas are available in both round and oval models. Both of these exhibit a traditional warm and rich sound.



MWM1MC

MWM2AM

Material Wood

## 6. RAWHIDE MARACAS

The MEINL Rawhide Maracas are entirely made by hand and are offered in three different sizes for a wide sonic range. The two larger models sound especially full and dry, whereas the smaller sized version produces a very tight and high pitched sound.

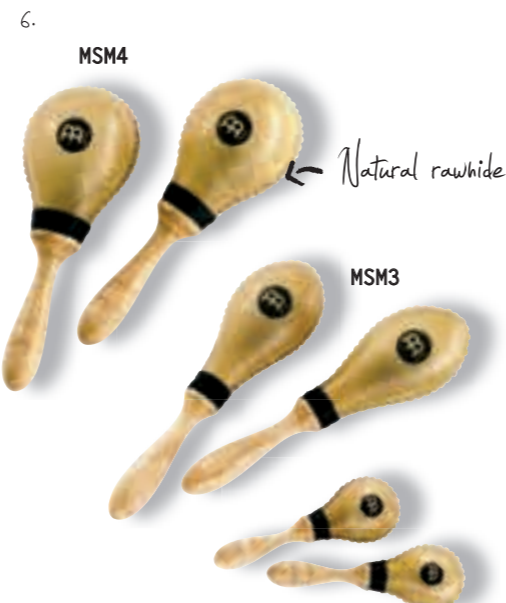

MSM4

MSM3

MSM2

Sizes Midi  
Traditional  
Jumbo

Materials Natural rawhide  
Wooden handle

Natural rawhide

## 7.

PM2BK



Materials Plastic  
Wooden handle

## 8.

GU7R



GU7BK



3 playing surfaces

Material Premium fiberglass  
Features Three striking surfaces  
Padded grip holes  
Includes Plastic scraper  
Colours BK = Black  
R = Red

## 7.

GU6BK



Material High strength plastic  
Features Three striking surfaces  
Rubber ringed grip holes  
Includes Plastic scraper  
Colour BK = Black

## 10.

GU2AB-M



Material Wood  
Features Three striking surfaces  
Grip holes  
Includes Plastic scraper  
Colour AB-M = African Brown  
Finish Matte

GU1AM



Material Wood  
Feature Grip holes  
Includes Wooden scraper  
Colour AM = Amber

## 11.

MC-GU



Material Chrome plated steel  
Feature Rubber pads against scratching



Idania Valdés, Cuba

Marina Chabanova, Ukraine

## 7. PLASTIC MARACAS

The MEINL Plastic Maracas produce a loud and crisp sound. They are very durable and comfortable to play.

## 8. FIBERGLASS GUIROS

The MEINL Fiberglass Guiros offer three different striking surfaces for enhanced sounds and padded grip holes.

## 9. PLASTIC GUIRO

The MEINL Plastic Guiro is precision molded from high strength plastic. It features three different striking surfaces and rubber ringed grip holes for maximum comfort and control.

## 10. WOOD GUIROS

The traditional MEINL Wood Guiros are available in two different versions and produce a warm and cutting sound.

## 11. GUIRO HOLDER

The MEINL Guiro Holder firmly attaches to any common rod and holds the guiro securely in place while it is played.

# Cabasas



Joannie Labelle, Canada



MC-CA

Material Chrome plated steel  
Features Strong mounting clamp  
Padded surface

1. CABASA HOLDER  
This unique attachment holds the cabasa safe and ready to use. The padded surface prevents it from slipping.

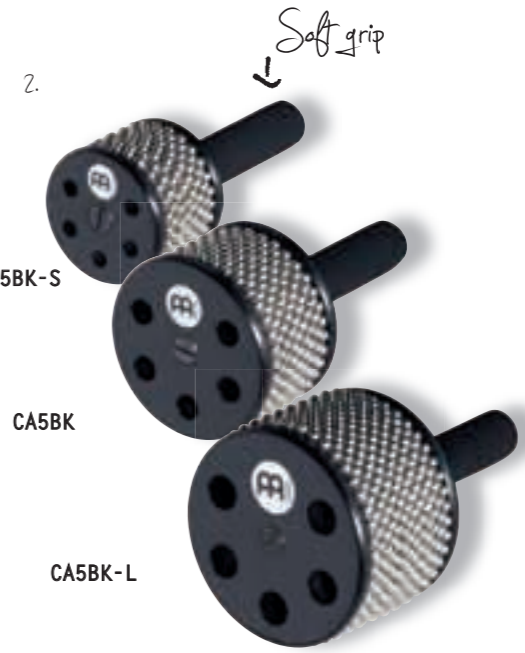

CA5BK-S

CA5BK

CA5BK-L

Sizes Small, regular, large  
Materials Steel chain and stainless steel cylinder  
Wooden handle with padded soft grip  
Feature 5 sound ports on each side for more volume (patent pending)  
Colour BK = Black

2. TURBO CABASAS (patent pending)  
The MEINL Turbo Cabasas are a great innovation, with significantly more volume than normal cabasas. This comes from the sound ports in the resonating chamber. The Turbo Cabasas bring the classic cabasa sound to a new level that will cut through any sonic environment.

3. FOOT CABASA (patent pending)  
The MEINL Foot Cabasa is a breakthrough instrument for the percussionist! We mounted a large Turbo Cabasa on our sturdy foot pedal (patent pending), which adds a new sound to your setup. Keep a cabasa rhythm while your hands play the congas or other drums! The MEINL Foot Cabasa can be set for either a single or double-stroke, according to your taste.

Torsten Franz, Germany



FCA5-L

Size Large  
Materials Steel chain and stainless steel cylinder  
Wooden body  
Black powder coated pedal  
Features Optional single or double-stroke setting  
5 sound ports on each side for more volume (patent pending)  
Includes Drum key  
Foot pedal

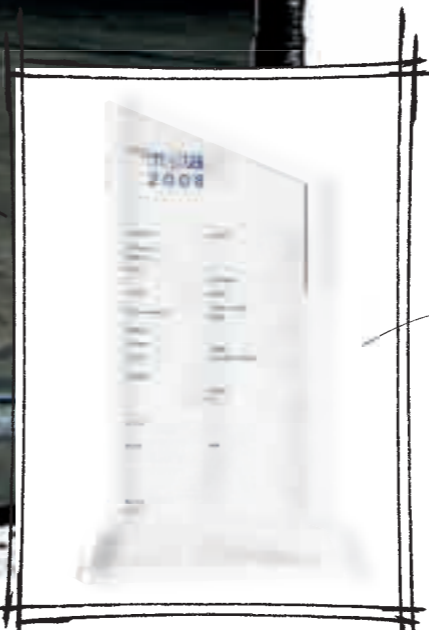

The Meinl Foot Cabasa won the MIPA Award in the "Best Percussion Product" category.

# Cabasas

# Ritual Drums

MEINL combines traditional instruments with modern technology and innovations. The range of Ritual Drums is a line of instruments which originate many different cultures from all around the world. MEINL's R&D expertise helped in creating these authentic and high quality instruments which are outstanding in the percussion world.

## 1. BERIMBAU

The MEINL Berimbau is traditional African instrument that is a commonly found in the music from Brazil and other South American countries. The thin striker and a caxixi are held in the right hand, while the left hand supports the bow and modulates the string with a small metal disc. The whole instrument is moved off-and-on the abdomen, opening and closing the resonant gourd, for a captivating "wah-wah" effect.

## 2. CABASA, FIBERGLASS

The shape and function of the MEINL Fiberglass Cabasa equals a traditional gourd calabash.

**Material** Premium fiberglass  
**Includes** Small Caxixi  
 Metal plate  
 Wooden stick  
 Carrying bag  
**Colour** R = Red



*Dado Sezzi, Italy*



## 2. CAZR

**CAZR**

**Material** Premium fiberglass  
**Colour** R = Red



*Adjustable net for various tensions and sound options*

## 3. TD7BK



**Size** 7 1/2"  
**Material** Premium fiberglass  
**Features** Durable synthetic heads  
 Wooden rims  
 Nylon tuning strap  
**Includes** Curved wooden beater  
**Colour** BK = Black

## 4. ATD-L



**Sizes** M = 7" x 12"  
 L = 8" x 16"  
 23 rope runners, 3 mm PP rope  
 28 rope runners, 3 mm PP rope  
**Materials** Mahogany Wood  
 Hand selected goat heads  
**Features** Carved from one solid piece of plantation grown Mahogany Wood  
 Nylon tuning strap  
 Ornamental carving  
**Includes** Curved wooden beater  
**Finish** Brown/Black

## 5. SH2VSB



**Material** Premium fiberglass  
**Colour** VSB = Vintage Sunburst

## 6. SH1BK



**Material** Premium fiberglass  
**Colour** BK = Black

## 3. TALKING DRUM

The Talking Drum has its origin in West Africa. The traditional technique involves squeezing the tuning ropes while striking the head with a thin bent wooden mallet.

## 4. AFRICAN TALKING DRUMS

The new MEINL African Talking Drums are carved into an hour-glass shape from a solid piece of Mahogany wood, and decorated with a carved motif. Two hand-selected goatskin heads are spanned with high-quality nylon rope. Traditionally, the talking drum is played beneath one arm, and held against the ribcage. The drum is then squeezed to "bend" the pitch while the other hand employs a curved striker.

## 5. SHEKERE, JUMBO SIZE

MEINL's Jumbo Size Shekere is hand made from premium fiberglass and fitted with a net of beads.

## 6. SHEKERE

The MEINL Shekere is handmade from premium fiberglass and fitted with a net of beads. It delivers a crisp sound and unlike gourd shekeres, it is nearly unbreakable.

## 7. TABLA

The new MEINL Tabla is a professional level pair of tablas in the time-honored Indian tradition. Multi-ply natural skin heads are secured by metal rings and rawhide verticals. Proper tuning is achieved by adjusting wooden rollers that are fitted under the rawhide verticals.



**NEW!**

**Sizes** 5 1/2"  
 8 1/2"  
**Materials** Chrome plated copper with goat skin  
 Rosewood with goat skin  
**Features** Authentic tabla heads  
 Traditional tuning system with rawhide leather strings  
**Includes** Padded support rings  
 Tuning hammer  
 Nylon bag



1. **RAMWONG7**  
 Size 7" diameter, 10" tall  
 Material Wood  
 Features Natural rawhide  
 Traditional rope tuning system

1. **RAMWONG**  
 Ramwong is a Thai folk dance which evolved from Ramthone, a popular festive season in a certain region in Thailand. Ram means dance and Thone is a small drum.

2. **TAMBORA**  
 The rhythm of the Merengue has its roots in the Dominican Republic where the use of a Tambora drum is essential in creating this style of music.

3. **WOOD CONGUITAS**  
 The Conguitas are a perfect addition to any percussion set up. They are made from high quality materials and produce a cutting and strong percussive tone which complements the congas in a harmonically supportive sound spectrum.

4. **BATAS**  
 The MEINL Batas are made from premium fiberglass for more durability, lighter weight and comfortable playing, and have a traditionally authentic sound.



Bill Summers, USA



2. **MTA1SNT-M**  
 Size 11"  
 Material Rubber Wood (Hevea brasiliensis Muell.-Arg.)  
 Features True Skin Buffalo Heads  
 Black powder coated hardware  
 Includes Nylon strap  
 Wooden beaters  
 Tuning key  
 Colour SNT-M = Super Natural  
 Finish Matte



3. **HCG89NT**  
 Sizes 8" & 9"  
 Material Rubber Wood (Hevea brasiliensis Muell.-Arg.)  
 Features 8 mm strong tuning lugs  
 Original MEINL style tuning brackets  
 Traditional rims  
 Black powder coated hardware  
 Hand selected buffalo heads  
 Includes Height adjustable tilting  
 double braced tripod stand  
 Tuning key  
 Wrench  
 Colour NT = Natural  
 Finish High gloss



4. **BA1BK BA2BK BA3BK**  
 Sizes Okonkolo 5 1/4" & 8"  
 Itotele 5 3/4" & 8 3/4"  
 Iya 6 3/4" & 12"  
 Material Premium fiberglass  
 Features Hand selected buffalo heads  
 Traditional TTR-Rims  
 Includes Nylon strap  
 Tuning key  
 Colour BK = Black



5. **TRIL**  
 Material Special steel alloy, filled with water  
 Feature Wide sound spectrum  
 Includes Metal beater  
 Finish Black nickel

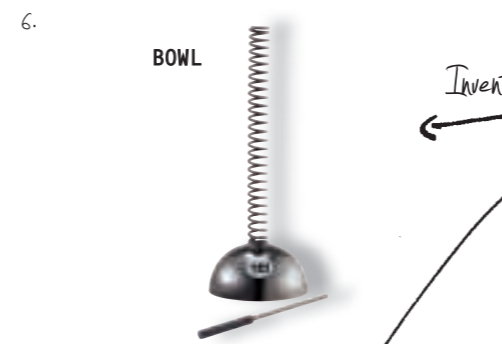

6. **BOWL**  
 Material Special steel alloy  
 Includes Metal beater  
 Finish Black nickel



Bill Saragosa, not from this world



7. **CONE**  
 Material Special steel alloy  
 Feature A set of two  
 Finish Black nickel



8. **RA7BK**  
 Material Premium fiberglass  
 Feature Circular construction  
 Includes Ergonomically shaped handle  
 Colour BK = Black



Made out of real Bamboo

9. **DDG1-BK DDG1-R**  
 Size 47" long (120 cm)  
 Material Bamboo  
 Includes Nylon bag  
 Colours BK = Black  
 R = Red

5. **LIQUID TRIANGLE, BILL SARAGOSA LINE**  
 The MEINL Liquid Triangle is a solid steel triangle, welded securely to a steel shell, creating a chamber which contains liquid and is closed with a very thin plate. The triangle portion may be played in the classical manner, while the chamber creates eerie resonant overtones.

6. **HELIX BOWL, BILL SARAGOSA LINE**  
 The MEINL Helix Bowl is a wonderful new instrument consisting of a steel helix welded to a resonating chamber. The Helix Bowl is either stroke or struck, and is played off the body in the manner of a berimbau, for a deep resonating wah-wah effect. Optional damping is possible with just a touch of a finger.

7. **CONE-STACK, BILL SARAGOSA LINE**  
 The MEINL Cone-Stack is a four-chambered shaker with some wild characteristics. Two balanced chambers are connected with a center screw, and may be played as a pair, or as one shaker. As a pair, they have a high and a low side, plus an open bell, also tuned high and low. They can be played like maracas. Screw them together, and you get a kind of multi-chambered stereo effect! It's a great, full sound with metallic overtones. You can play it sort of like a shekere, or wah-wah the open bell chambers, or clasp it in the middle balance point for fine shaker techniques.

8. **RAINMAKER**  
 The MEINL Rainmaker is uniquely different. Due to the circular construction, it can be mounted on a cymbal stand and by simply turning the instrument a drizzle can immediately change into the sound of a monsoon.

9. **DIDGERIDOOS**  
 The new MEINL Didgeridoos are a great way to get started on the oldest wind instrument in the world. It makes a distinctive drone with harmonic overtones, and goes great with all kinds of percussion. Our didgeridoos are made from bamboo.



**1. BIRDS/WATERFALL WITH HANDLE**

The MEINL wooden Birds and Waterfall pod rattles are our popular sound effects now woven onto a handgrip. The result is a hand-held pod rattle with full control.

**2. BIRDS/WATERFALL, FIBERGLASS**

The MEINL Birds and Waterfall realistically imitate the sound of a flock of birds or a rippling waterfall. By using fiberglass a bright sound is produced, the dynamic range is increased and an optimum durability is realized.

**3. BIRDS/WATERFALL, WOOD**

The MEINL Birds and Waterfall made out of Rubber Wood (*Hevea brasiliensis* Muell.-Arg.) enable a brighter timbre and a more penetrating sound.

**4. WAH-WAH TUBES**

The MEINL Wah-Wah Tube is a tubular effect instrument that delivers smooth, bell-like tones with an incredible sustain.

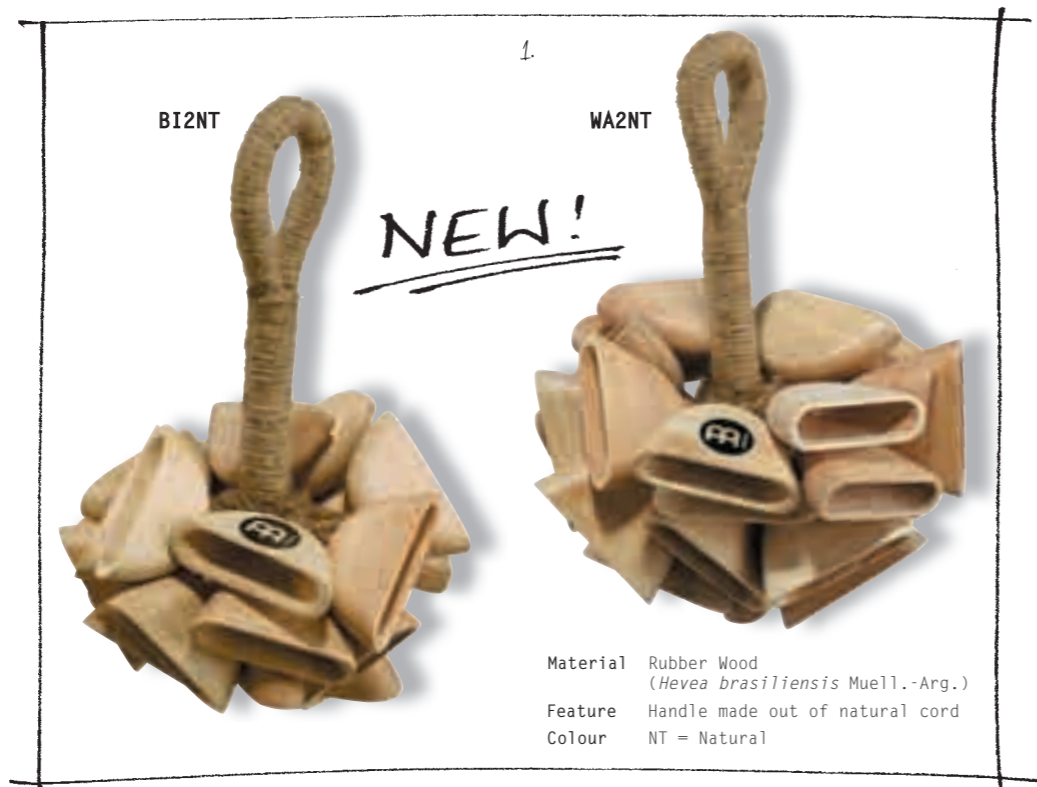

**Paulee**

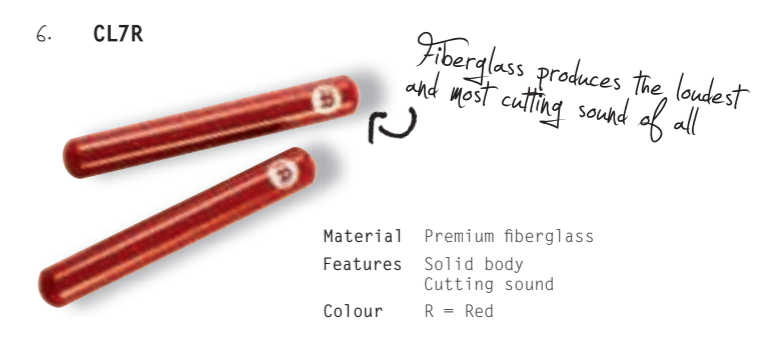

**5. CLAVES DE LUXE**

The MEINL Claves De Luxe are made from a superb, dense hardwood which delivers a cutting and bright tone. Due to their small size, they are portable and convenient but still enable a loud, solid rhythmic foundation on stage and in studio sessions.



**6. FIBERGLASS CLAVES**

The MEINL Fiberglass Claves produce the most penetrating, loud, and cutting sound of all. They are hand made from premium fiberglass which makes them nearly indestructible.



**7. WOOD CLAVES, CLASSIC**

The MEINL Classic Wood Claves are the most common claves and produce the classic cutting sound. Both the clave and the striker have the same size.

**8. WOOD CLAVES, AFRICAN**

African Claves are slightly larger and have a lower fundamental pitch. Additionally, the resonating body is larger than the striker. Available in two different versions: Solid and hollowed out body.

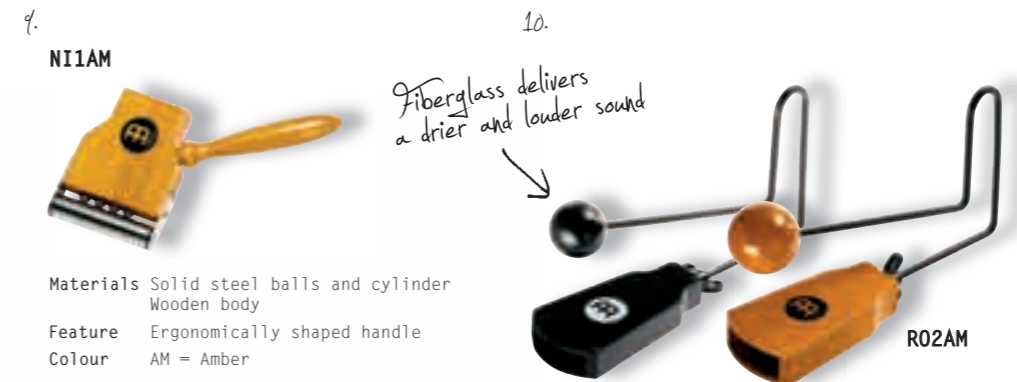

**9. THE NIGHT**

When playing The Night, four solid steel balls hit a cylindrical metal rod in quick succession producing the unique sound of crickets.

**10. THE ROAR**

The MEINL Roar is available as a wood and as a fiberglass version. A rattling effect is achieved by striking the ball end against the palm of the hand.

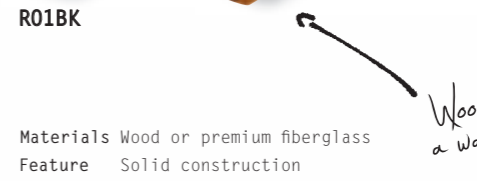

Christina Gernert, Lina Anschütz, Lina Maul and Shanice Kaiser

Kenny Reh

Kübra Kayaaslan

# Ibo Drums

The MEINL Ibo Drums perfectly combine tradition with modern innovation. "Ibo" is the Nigerian name for "pottery" where these unique drums originate. They all have a wide spectrum of sounds, are easy to play and offer many great features.

## 1. FIBERGLASS LIQUID IBO DRUM

The new MEINL Fiberglass Liquid Ibo Drum is a new twist on our classic ibo drum. A sealed metal chamber containing water is permanently bonded to the premium fiberglass body. The liquid chamber adds fluctuating overtones to the drum's fundamentals. It's easy and it's fascinating! The liquid fluctuations give you new sounds at every turn of the hands.

1. **ID9BK/WH**

**NEW!**



Size Large  
Material Premium fiberglass  
Features Special bottom, filled with water  
Built-in microphone hole  
Resistant shell construction  
Includes Foam padded base  
Colour BK/WH = Black/White

*The new Fiberglass Liquid Ibo Drum is filled with water*

## 2. FIBERGLASS IBO DRUM

The MEINL Fiberglass Ibo Drum has a wide variety of different sounds and the fiberglass body makes it nearly unbreakable.

2. **ID1BKR**



*Built in microphone hole*

Size Large  
Material Premium fiberglass  
Features Built in microphone hole  
Resistant shell construction  
Includes Foam padded base  
Colour BKR = Black/Red

## 3. FIBERGLASS IBO DRUM, LONG NECK

The MEINL Fiberglass Ibo Drum with long neck has a wide variety of different sounds and the fiberglass body makes it nearly unbreakable.

3. **ID2BKR**



*Resistant shell construction*

Size Long neck  
Material Premium fiberglass  
Features Built in microphone hole  
Resistant shell construction  
Includes Foam padded base  
Colour BKR = Black/Red

## 4. FIBERGLASS TRI SOUND IBO DRUM

The MEINL Tri Sound Ibo Drum features an additional rawhide playing surface and an extra thin bottom for enhanced sound.

4. **ID3GO**



*Rawhide playing surface*

Size Large  
Material Premium fiberglass  
Features Rawhide playing surface  
Built in microphone hole  
Resistant shell construction  
Includes Foam padded base  
Colour GO = Gold Ornament

*Extra thin bottom for enhanced sound*

## 5. IBO HOLDER

The MEINL Ibo Holder securely supports most common ibo drums in a comfortable position while enabling you to play the ibo with both hands, or with one hand free for other instruments.

5. **TMID**



*Foam padded ring*

Material Chrome plated steel  
Features Foam padded ring  
Fully height- and angle adjustable  
Double braced tripod legs  
Includes Allen wrench  
Memory lock

## 6. FIBERGLASS TRI SOUND IBO DRUM

The MEINL Tri Sound Ibo Drum features an additional fiberglass playing surface and an extra thin bottom for enhanced sound.

6. **ID4BKO**



*Extra fiberglass playing surface*

Size Large  
Material Premium fiberglass  
Features Extra fiberglass playing surface  
Built in microphone hole  
Resistant shell construction  
Includes Foam padded base  
Colour BKO = Black Ornament

## 7. WOOD IBO DRUM

This unique instrument is another true MEINL innovation. It features a wooden body for a wide sonic range.

7. **ID6**



*Hand carved ornaments*

Size Large  
Material Made from Mango Wood (Mangifera Sp.L.)  
Features Dry tones  
Built in microphone hole  
Includes Foam padded base

*Wood enables a drier sound*

## 7. ID7RB

*Full and rich sound due to ceramic body*



Size Large  
Material Ceramic  
Features Full and rich sounds  
Built in microphone hole  
Includes Foam padded base  
Colour RB = Red/Brown

## 8. ID8RB

*Extra fiberglass bottom for more sound options*



Size Large  
Material Ceramic  
Features Fiberglass playing surface  
Built in microphone hole  
Includes Foam padded base  
Colour RB = Red/Brown



*Ramesh Shotham, Germany*

## 7. CERAMIC IBO DRUM

The ceramic body of this Ibo Drum causes a slight enhancement of the higher frequencies, with fat and powerful bass tones.

## 8. CERAMIC IBO DRUM

The special feature of this MEINL Ceramic Ibo Drum is the fiberglass bottom for extra sound options.



10. **MIB-S** **MIB-M**

Sizes Small (9 3/4" W x 13 1/3" H x 9 3/4" D)  
Medium (11" W x 14 1/2" H x 11" D)  
Material Heavy duty padded nylon  
Includes Padded shoulder strap  
Carrying grip  
External pocket

## 9. PROFESSIONAL IBO STAND

The MEINL Ibo Stand was designed to enable playing an Ibo Drum in ways other than simply being placed in one's lap, such as standing up or incorporating it into a percussion set up. It can be angled and is fully height adjustable.

## 10. PROFESSIONAL IBO BAGS

The MEINL Ibo Bag fits all common clay drum models and is the perfect solution for transporting these valuable and fragile instruments.



# Headliner® Series Dancing Drums

The MEINL Headliner® Series Dancing Drums are the perfect instruments for educational or street percussion. They are made from high quality materials and produce great sounds. A great gift idea as well.

1. FIBERGLASS DANCING CONGA
2. FIBERGLASS DANCING DJEMBE
3. FIBERGLASS FAMILY DRUMS
4. FIBERGLASS MINI DANCING DJEMBE

*Eye catching multi colour finish*

HC301MC



Size 8 1/2" 24" tall  
 Material Premium fiberglass  
 Features 7 mm strong tuning lugs  
 2.2 mm rounded rim  
 Black powder coated hardware  
 Includes Nylon strap  
 Tuning key  
 Colour MC = Multi colour

2.

HDJ400MC



Size 12" 22 3/4" tall  
 Material Premium fiberglass  
 Features 7 mm strong tuning lugs  
 2.2 mm rounded rim  
 Black powder coated hardware  
 Includes Nylon strap  
 Tuning key  
 Colour MC = Multi colour

3.

Sizes HFDD1MC = 8 3/4", tall 13 1/2"  
 HFDD2MC = 8", tall 11 1/4"  
 HFDD3MC = 7 1/2", tall 9 3/4"  
 Material Premium fiberglass  
 Features 8 mm strong tuning lugs  
 Traditional rim  
 Black powder coated hardware  
 Includes Nylon strap  
 Tuning key  
 Colour MC = Multi colour



HFDD2MC

HFDD3MC

4.

HDJ200MC



Size 8", tall 11 1/3"  
 Material Premium fiberglass  
 Features Traditional rim  
 Black powder coated hardware  
 Floatune Tuning System  
 Includes Nylon strap  
 Tuning key  
 Colour MC = Multi colour



## Carlos "Carly" Maldonado, Puerto Rico

Carlos "Carly" Maldonado was born in Puerto Rico. He is a multipercussionist that has mastered the arts of hand, keyboard and symphonic percussion, and drum set as well. He is one of the new young percussion talents to have come out of PR as of late, and has collaborated with many different artists from different genres.

Currently he is playing with one of Latin music's top artists, Victor Manuelle (a Grammy nominee with more than a million records sold around the world), and has been featured on the artist's recordings, "Live from Madison Square Garden NY DVD and CD" and "Live from Carnegie Hall New York CD" playing percussion and drum set.

He is also a long time member of one of the most important rock/reggae bands in Latin America, Milla Torres y El Tercer Planeta and has been featured on certain recordings, including the hit CD "Masa con Masa."

Carlos has also travelled to many countries in Latin America, Europe as well as to the USA, always searching for and learning about the music of every culture and the percussion instruments involved.



Saboula  
Bangoura

Krulkova

Emmanuel (Mano) Pitsiladis

Joe Senegal

Casey Bond

## Headliner® Series Dancing Drums

FIBERGLASS DANCING CONGA, DJEMBE, FAMILY DRUMS, MINI DJEMBE  
 CARLOS MALDONADO

# Doumbeks

MEINL Doumbeks come from the same geographical points of origin as the darbukas, and are a favourite choice of drum for percussionists world-wide. Our doumbeks feature an ergonomic, Egyptian-style rounded rim with internal tuning lugs and a synthetic head. The bearing edge is carefully machined to assure consistent tuning. The doumbeks are well suited for fast finger-roll techniques and have a strong projection. The shells are constructed from various materials, each offering a wide range of timbres, weights and visual aesthetics.



## 1. COPPER DOUMBЕК, HAND ENGRAVED

The copper shell of this MEINL Doumbek is hand engraved for a stunning look. A very traditionally looking and sounding instrument.

1.



Size 8 1/2" x 17 1/8"  
Material Copper  
Features Synthetic head  
Hand engraved shell  
Includes Carrying bag  
Spare head  
Tuning key

## 2. ALUMINUM DOUMBЕК, HAND-HAMMERED

The aluminum shell of this MEINL Doumbek is completely hand-hammered for a most appealing look.

2.



Size 8 1/2" x 17 1/8"  
Material Aluminum  
Features Synthetic head  
Hand-hammered shell  
Includes Carrying bag  
Spare head  
Tuning key

## 3. ALUMINUM DOUMBЕKS

Hand made entirely of aluminum, the MEINL Doumbek is outstanding in sound and quality, reaching from resonant lows to ringing highs. Available as black vinyl covered or copper finished versions.

3.



Size 8 1/2" x 17 1/8"  
Material Aluminum  
Feature Synthetic heads  
Includes Carrying bag  
Spare head  
Tuning key

4.



Size 8 1/2" x 17 1/8"  
Material Aluminum  
Features Synthetic head  
Wood covered shell  
Includes Carrying bag  
Spare head  
Tuning key



Size M = 7" x 12"  
L = 8" x 16"  
Material Mahogany Wood  
Features Carved from one solid piece of plantain grown Mahogany Wood  
Pre-tuned goat head  
Comfortable rounded rim  
Hand carved ornaments  
Colour Brown  
Finish Matte

## 4. ALUMINUM DOUMBЕК, WOOD COVERED

The shell of this MEINL Doumbek is made from aluminum and is completely covered with a layer of the finest wood.

## 5. WOOD DOUMBЕKS

The new MEINL Wood Doumbeks are great sounding, light weight wooden doumbeks with decorative tribal carving on the foot. Goatskin heads are securely fastened over the Egyptian style bearing rims, which is preferred for finger roll techniques.

## 6. PROFESSIONAL DOUMBЕК BAG

The MEINL Doumbek Bag is made from heavy duty padded nylon with reinforced stitching and is equipped with a double-slide zipper, a padded shoulder strap, and a carrying grip.

6.



Material Heavy duty padded nylon  
Features Double-slide zipper  
Additional upright zipper  
Padded shoulder strap  
Carrying grip  
External pocket

## 7. PROFESSIONAL DOUMBЕК STAND

The MEINL Doumbek Stand was designed to enable incorporating a Doumbek into a percussion- or drum set-up. An adjustable, foam padded ring holds the Doumbek Drum firmly and prevents it from sliding or falling down. It can be angled and is fully height adjustable.

7.

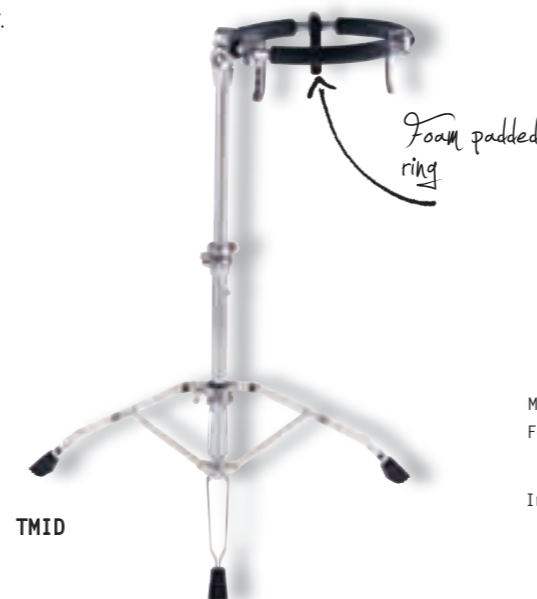

Material Chrome plated steel  
Features Foam padded ring  
Fully height- and angle adjustable  
Double braced tripod legs  
Includes Allen wrench  
Memory lock



# Darbukas

MEINL Darbukas are made in the tradition of the original, esoteric goblet-shaped drums found in music from Eastern Europe, the Middle East and Southern Asia. Our darbukas are constructed from thin shells in various metals, each metal giving the different models their special timbre. The head is secured and tuned with external rings set close to the shell, in the Turkish-style. Light yet powerful, the darbukas have a deep full bass. They are well suited for high-pitched snapping sounds as well as a wide range of articulated "doum" and "tak" strokes.



## 1. ALUMINUM DARBUKAS, PLAIN

These Turkish style MEINL Darbukas feature fat lows and ringing highs with a wide range in between.

## 2. ALUMINUM JINGLE DARBUKAS, HAND-HAMMERED

These MEINL Aluminum Darbukas feature a beautifully hand-hammered shell and built in jingles which adds a nice rattling effect and enhances their sound spectrum tremendously.



**Sizes**  
 HE-100 = 5 1/3"x9 1/4"  
 HE-101 = 5 7/8"x11"  
 HE-102 = 6 1/2"x12 3/4"  
 HE-103 = 7 1/4"x13 1/3"  
 HE-104 = 8"x14 1/2"

**Material** Aluminum  
**Feature** Synthetic heads  
**Includes** Tuning key



**Sizes**  
 HE-314 = 8"x14 1/2"  
 HE-315 = 8 1/4"x16"

**Material** Aluminum  
**Features** Built in jingles  
 Synthetic heads  
 Hand-hammered shells  
**Includes** Tuning key

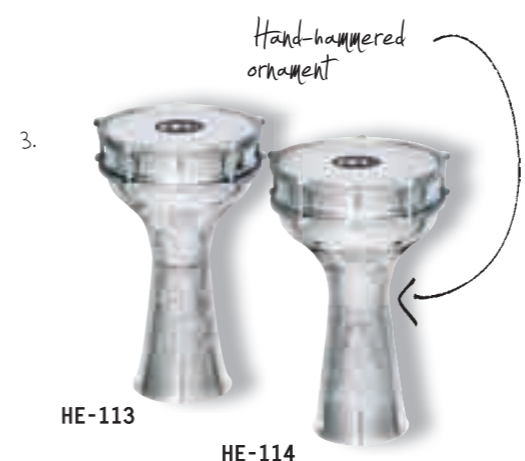

**Sizes**  
 HE-113 = 7 1/4"x13 1/3"  
 HE-114 = 8"x14 1/2"

**Material** Aluminum  
**Features** Synthetic heads  
 Hand-hammered shells  
**Includes** Tuning key



**Sizes**  
 HE-214 = 7 1/2"x14 3/4"  
 HE-215 = 7 7/8"x15 1/2"

**Material** Copper  
**Features** Synthetic heads  
 Hand-hammered shells  
**Includes** Carrying bag  
 Spare head  
 Tuning key



**Sizes**  
 HE-204 = 7 1/2"x14 3/4"  
 HE-205 = 7 7/8"x15 1/2"

**Material** Copper  
**Features** Natural rawhides  
 Hand engraved shells  
**Includes** Carrying bag  
 Spare head  
 Tuning key



**Material** Heavy duty padded nylon  
**Features** Double-slide zipper  
 Additional upright zipper  
 Padded shoulder strap  
 Carrying grip  
 External pocket

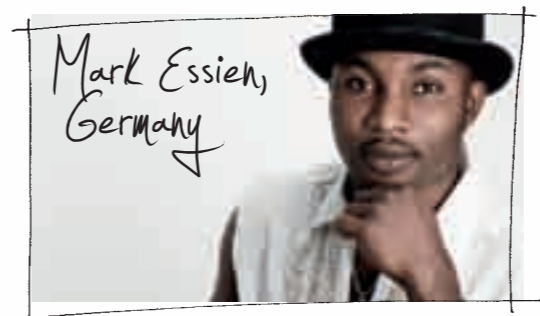

# Hardware

A professional mounting system requires stability and flexibility. The Original MEINL Hardware features the highest quality workmanship to provide a large variety of set up solutions for both percussionists and drummers alike. A system of well thought out clamps, holders, rods, and attachments for literally any set up or space situation.

1.

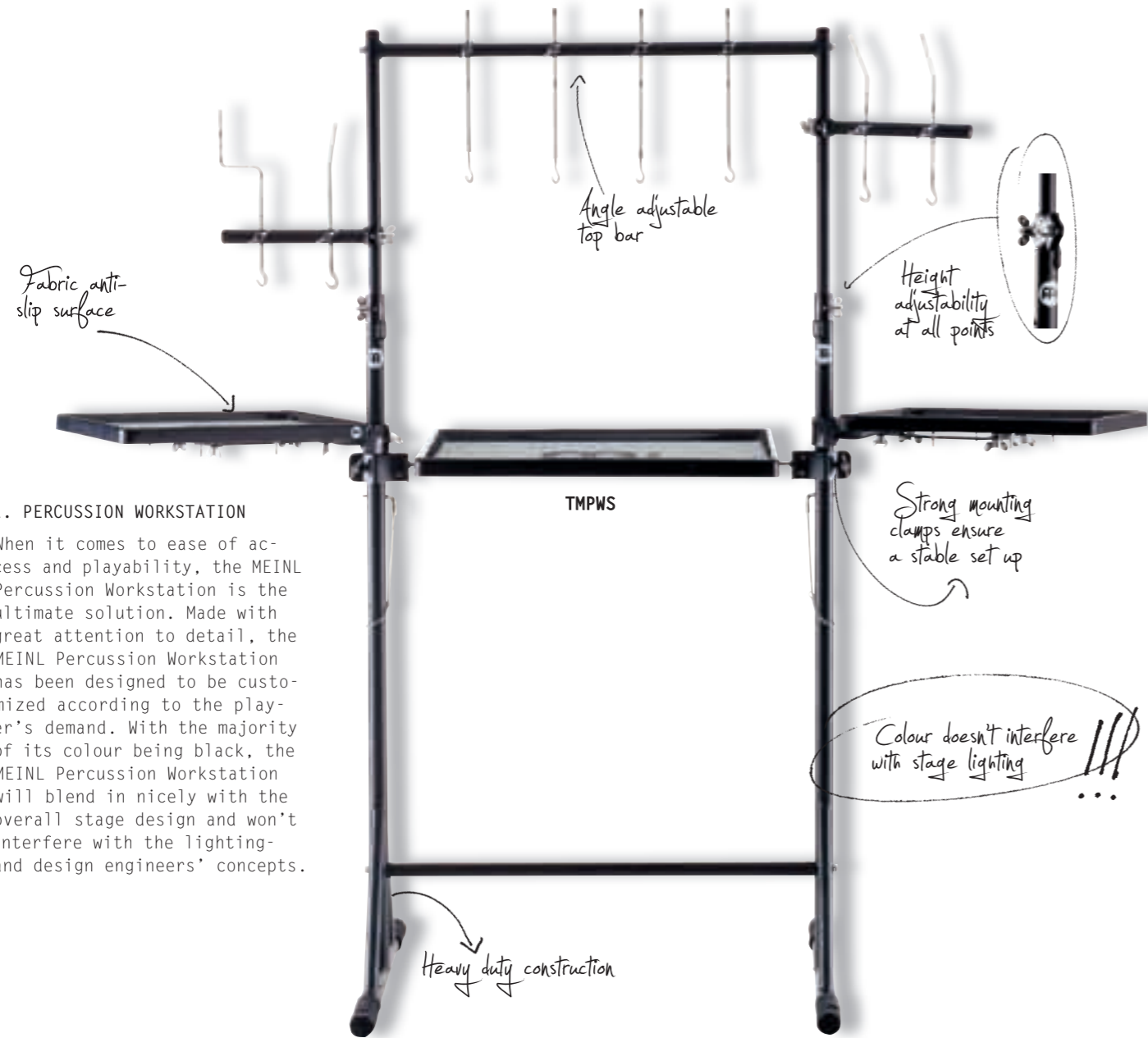

## 1. PERCUSSION WORKSTATION

When it comes to ease of access and playability, the MEINL Percussion Workstation is the ultimate solution. Made with great attention to detail, the MEINL Percussion Workstation has been designed to be customized according to the player's demand. With the majority of its colour being black, the MEINL Percussion Workstation will blend in nicely with the overall stage design and won't interfere with the lighting- and design engineers' concepts.

TMPWS

**Material** Black powder coated steel  
**Features** Fully height adjustable  
 Angle adjustable top bar  
 Fabric anti-slip surface  
 Heavy duty construction  
 Infinitely expandable  
 Fabric anti-slip surfaces  
 Colour doesn't interfere with stage lighting

**Includes** 1 pc 22" x 24" padded fiberglass percussion table  
 2 pcs 18" x 12" padded fiberglass percussion tables (attachable)  
 1 pc 30" vertical bar  
 2 pcs 15" vertical bars (attachable)  
 4 pcs straight rods with hook  
 3 pcs angled rods with hook  
 1 pc Z-shaped rod with hook



Stephan Maass, Austria

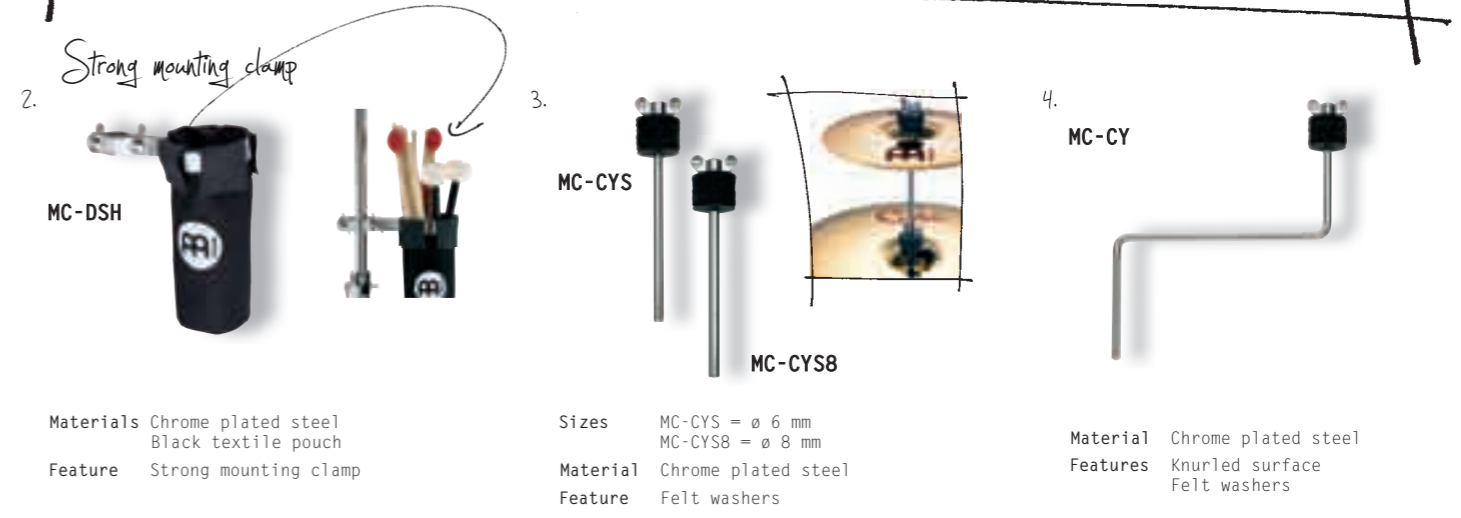

**Materials** Chrome plated steel  
 Black textile pouch  
**Feature** Strong mounting clamp

**Sizes** MC-CYS = ø 6 mm  
 MC-CYS8 = ø 8 mm  
**Material** Chrome plated steel  
**Feature** Felt washers

**Material** Chrome plated steel  
**Features** Knurled surface  
 Felt washers

## 2. DRUMSTICK HOLDER

The MEINL Drumstick Holder firmly attaches to any common stand and stores a number of drumsticks, mallets, brushes and other accessories in its roomy pouch for ready access when needed.

## 3. CYMBAL STACKERS

The MEINL Cymbal Stackers enable a space saving set up of various cymbals on top of each other.

## 4. CYMBAL HOLDER

This MEINL holder comfortably places any cymbal within a drum or percussion set up.



Markus "Baphmet" Mayer

Udo Heubeck

Mario Schmitt

Werner Stubenvoll

Stephan Sachs

# Tables & Stands Bars & Clamps

## 1. PERCUSSION TABLES

The MEINL Percussion Tables are made from durable fiberglass and offer enough room for all common hand percussion instruments. It can be attached to all common stands. Through its innovative design the angle of the table can be adjusted.

1.



Fabric anti-slip surface

Strong mounting clamp

MC-PT

MC-PTS

Sizes MC-PT = 18"x12"  
MC-PTS = 12"x12"  
Material Premium fiberglass

Features Fabric anti-slip surface  
Adjustable angle  
Strong mounting clamp

## 2. PERCUSSION STAND

The MEINL Percussion Stand is a universal device which offers a variety of set up solutions for both drummers and percussionists. It is fully height adjustable and features both quick locks and memory locks for a quick set up.

2.

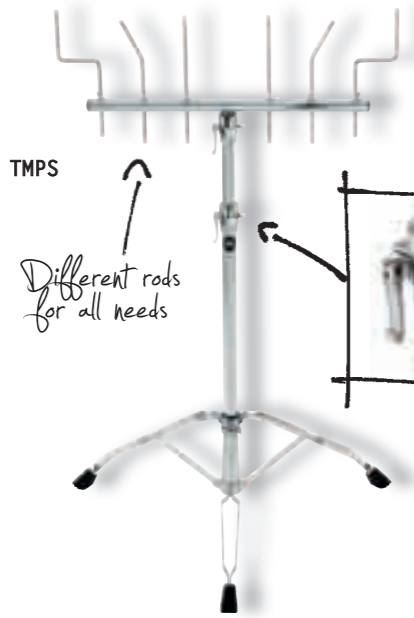

TMPS

Different rods for all needs

3.

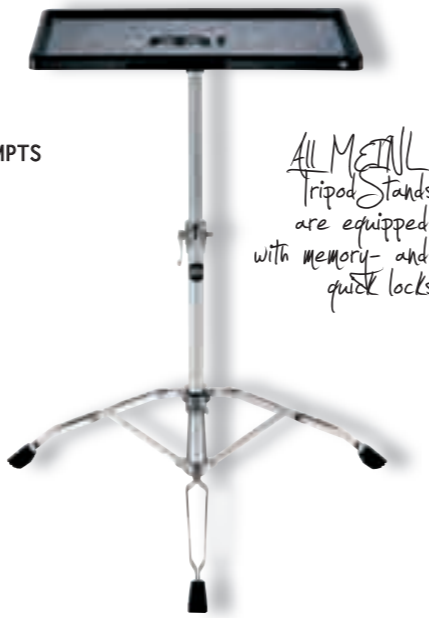

TMPTS

All MEINL Tripod Stands are equipped with memory- and quick locks

## 3. PERCUSSION TABLE STAND

The MEINL Percussion Table Stand offers enough room for all common hand percussion instruments. It is fully height adjustable and has a fabric anti-slip surface.

## 4. PEDAL MOUNT

The MEINL Pedal Mount fits on all common bass drum pedals and firmly holds cowbells, blocks, or tambourines. It is height adjustable and contains metal spikes attached to the bottom of the legs, holding the entire unit in place without movement.

4.

PM-1



Metal spike for more stability

Material Black powder coated steel  
Features Height adjustable legs  
Metal spikes attached to the bottom of the legs  
Includes 2 differently sized L-rods

5.

MC-1

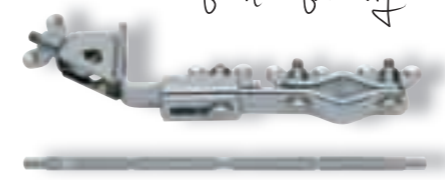

Length adjustability for more flexibility

Material Chrome plated steel  
Features Length adjustable  
Strong mounting clamp  
Includes Straight rod

6.

CLAMP

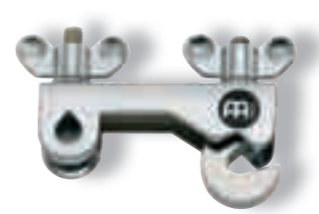

Material Chrome plated steel  
Feature Compact and solid design

7.

MC-2



Material Chrome plated steel  
Features Length adjustable  
Strong mounting clamp  
Includes 2 straight rods

8.

PMC-6

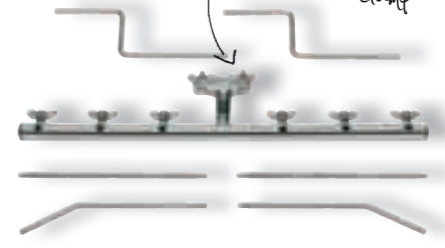

Strong mounting clamp

Material Chrome plated steel  
Includes 2 straight rods  
2 angled rods  
2 Z-shaped rods

9.

MC-4

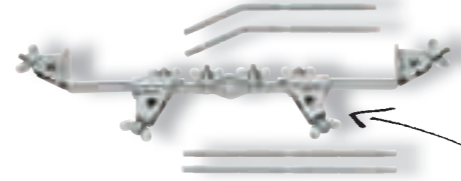

Length adjustability for more flexibility

Material Chrome plated steel  
Features Length adjustable  
Strong mounting clamp  
Includes 2 straight rods  
2 angled rods

10.

MC-R1

MC-R2

MC-R3

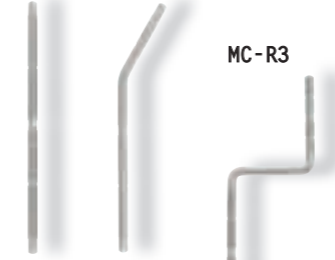

Shapes Angled rod  
Straight rod  
Z-shaped rod  
Material Chrome plated steel  
Features Knurled surface

## 5. MULTI CLAMP, ONE MOUNT

The MEINL Multi Clamp easily attaches to any common stand. Its unique feature is the length adjustability to fit any given space situation. It holds one rod.

## 6. CLAMP

The MEINL Percussion Clamp attaches to the lug of a conga, bongo, or djembe for mounting an additional cowbell, block, or tambourine.

## 7. MULTI CLAMP, TWO MOUNTS

The MEINL Multi Clamp easily attaches to any common stand. Its unique feature is the length adjustability to fit any given space situation. It holds two rods.

## 8. MOUNTING BAR, 6 PCS.

The MEINL Mounting Bar can easily be attached to any stand. It's ideal for expanding your percussion or drum set up.

## 9. MULTI CLAMP, FOUR MOUNTS

The MEINL Multi Clamp easily attaches to any common stand. Its unique feature is the length adjustability to fit any given space situation. It holds four rods.

## 10. RODS

A variety of differently shaped rods can hold several mountable hand percussion instruments.



Hardware

# Candela Percussion Cymbals

The MEINL Candela Series of Percussion Cymbals have been designed to meet the specific requirements of today's percussionists. They are extremely thin cymbals which produce soft, exotic tones, are tonally matched and respond even at lower volumes.

1.



Sizes 14"  
16"  
Material B20 Bronze  
Features Hand-hammered  
Brilliant finish  
Fast response and attack  
Quick decay

## 1. PERCUSSION CRASHES

The crashes are thin, tonally matched cymbals which can be played by hand or hit with a stick. They respond fast and decay quickly.

## 2. PERCUSSION SPLASH

The percussion splash is an extremely thin, quick sounding cymbal - perfect for fast percussive accents.

## 3. PERCUSSION JINGLE BELL

A great cymbal with an exotic sound. Six pairs of jingles attached to this cymbal produce a rattling effect.

## 4. TIMBALE CRASH/RIDE

It's the perfect cymbal for timbale playing. It has a loud, penetrating bell and a full, warm crash sound.

2.



CA10S

Size 10"  
Material B20 Bronze  
Features Hand-hammered  
Brilliant finish  
Fast response and attack  
Quick decay

Quick response when hit by a hand

3.



CA14PJB

Size 14"  
Material B8 Bronze  
Features Precisely hammered  
Built in jingles

4.



CA18CR

Size 18"  
Material B20 Bronze  
Features Hand-hammered  
Brilliant finish  
Cutting bell sound  
Great crash sound

# Roland Peil, Germany

Well, I started playing classical percussion at the age of ten. When I first came across a pair of bongos I couldn't let go.

Somebody said, "you like to play bongos, so why don't you learn to play them?" Very funny!

When I learned more about all those marvellous instruments like Congas, Timbales, Cowbells, Berimbau, Cuica, Caxixi etc., etc., etc..... I truly fell in love with them.

Along the way one thing led to another, and thanks to the support of my parents and a lot of 'circumstances,' I was able to make my living as a...multi-percussionist! Bands like Santana and Seis del Solar but also Earth, Wind and Fire, Al Jarreau, Marvin Gaye, Talking Heads, B52's, and many, many more got me on my way.

In 1992 I went to Cuba for the holidays, and I never ever got away from it...Rumba, Batá, Timba, Son and all those lovely genres of music around there. How marvellous was that?!

I have always liked the variety of musical genres where percussion fits in, and I have never hesitated to "jump in the cold water." Jazz, Pop, Classical, R&B, Soul, Hip-hop...whatever style, I always found a way to contribute without overdoing it.

I'm afraid that's becoming too long!/?  
So to shorten it a bit:

Die Fantastischen Vier, Till Brönner, Sarah Brightman are my gigs this year and I hope I'll be able to leave my mark in many more bands in the future as well as find some time to play some gigs with my band Roland's Rumba a.k.a. Calvimetero.

Thx to my loving family.



Yogi Jockusch, Germany





# Gear

## 1. PROFESSIONAL CYMBAL TROLLEY

The MEINL Cymbal Trolley holds cymbals up to 22" in diameter and has an external compartment for cymbals up to 16" in diameter. The entire bag is mounted on stable wheels and has a retractable handle. An extendable leg ensures 100% stability when not in transit.



Size 22"  
Materials Bag: Heavy duty padded nylon  
Wheels: Hard plastic  
Features External cymbal compartment  
External accessory compartment  
Internal padded cymbal dividers  
Stable wheels  
Length adjustable grip

## 2. PROFESSIONAL CYMBAL BAGS

The MEINL Cymbal Bags are available in three sizes: 16", 22" and 24" diameters. The 16" Cymbal Bag has a small external pocket for other Drum Gear. The 22" and 24" Cymbal Bags have an external hihat/splash compartment designed to hold cymbals up to 15" in diameter.

The 16" cymbal bag has a small external pocket for other gear



Sizes 16", 22", 24"  
Material Heavy duty padded nylon  
Features External compartment  
Padded dividing pads  
Padded shoulder strap  
Carrying grip

## 3. DESIGNER CYMBAL BAGS

The MEINL 22" Designer Cymbal Bags are available in different finishes. Two external compartments hold cymbals up to 15" in diameter and allow storage of sticks and other drum accessories.



Size 22"  
Material Heavy duty padded nylon  
Features External compartment  
Padded dividing pads  
Padded shoulder strap  
Carrying grip  
Colours Earth Camouflage  
Leopard  
Original Camouflage  
Urban Camouflage  
Zebra



Cymbals and sticks are always ready at hand.

**NEW!**



Size 22"  
Materials Bag: Heavy duty padded nylon  
Features External compartment  
Padded dividing pads  
Padded shoulder strap  
Carrying grip  
Colours Black  
Original Camouflage

## 4. COMBO BAGS

An exceptional combination of a MEINL 22" Cymbal Bag and a MEINL Stick Bag. They come together from a zipper on the backside. Cymbals and sticks are always ready at hand.

## 5. DESIGNER STICK BAGS

The MEINL Designer Stick Bags are available in five different finishes. Four spacious sections for drumsticks and a separate compartment for drum accessories.

## 6. PROFESSIONAL STICK BAG

The MEINL Stick Bag offers four spacious sections for drumsticks and a separate compartment for drum keys, small tools and other valuables.

## 7. DELUXE STICK BAG

The MEINL Deluxe Stick Bag offers some special features. Spacious sections for drumsticks featured with zippered clear window pockets and two external pockets for extra gear.



Material Heavy duty padded nylon  
Features External pockets  
Shoulder straps  
Extension straps  
Colours Earth Camouflage  
Leopard  
Original Camouflage  
Urban Camouflage  
Zebra



Material Heavy duty padded nylon  
Features External pockets  
Shoulder straps  
Extension straps  
Colour Black



Material Padded synthetic leather  
Features External pockets  
Shoulder straps  
Elastic cord attachments  
Colour Black



# NINO®

## FIRST MOVE

The new generation of musical instruments for early childhood education.

NINO® instruments meet exactly the requirements of early childhood education and are perfectly suitable for use in kindergartens, schools, music therapy, and for musical activities at home.

Easy handling and an appealing design are standard for all NINO® instruments. They are noteworthy due to their professional features, great sounds and their outstanding quality. The strong, child-proof workmanship guarantees years of trouble-free use of all NINO® instruments.

## DIRECTORY

PRODUCT GROUP	PAGE
Congas	146
Bongos	148
Cajons	149
Frame Drums	151
Hand Percussion	152
Shakers	160
Nino® Sets	162
Nino® Rhythm Sets	163
ABS Drums	164
Djembes	166
Shake'n Play	168
Glockenspiel	169
Safety	170

All NINO® products are designed for children ages three years and up.

Nino® Percussion

FIRST MOVE

# Congas

NINO® Congas are famous for their professional workmanship in fiberglass or wood sets. They all include basket stands and can therefore be played individually or in a set configuration.

## 1. NINO® DESIGNER SERIES CONGAS - MUSICAL ZOO

The new NINO® Musical Zoo Designer Series Congas are decorated with a delightful collection of musical friends. They send a positive message about music making and fun!

## 2. FIBERGLASS CONGA SET

Our fiberglass is a high quality material, manufactured by hand, into especially powerful sounding shells. The advantage over wood congas is the lower weight which makes handling much easier.

## 3. NINO89 WOOD CONGA SET

The NINO89 Wood Congas can be played standing up or sitting down and are therefore the perfect congas for children in kindergartens.



**NINO89MZ**

**Sizes** 8" & 9"  
22" tall  
**Material** Rubber Wood with appliqué graphics (Hevea brasiliensis Muell.-Arg.)  
**Features** Hand selected buffalo heads  
Rounded rims for playing comfort  
Black powder coated hardware  
**Includes** Basket stands  
Tuning key  
**Finish** MZ = Musical Zoo



**NINO910DS**

**Sizes** 9" & 10"  
28" tall  
**Material** Rubber Wood with appliqué graphics (Hevea brasiliensis Muell.-Arg.)  
**Features** Hand selected buffalo heads  
Rounded rims for playing comfort  
Black powder coated hardware  
**Includes** Height adjustable basket stands with quick set up system  
Tuning key  
**Finish** DS = Deep Sea

## 4. NINO® DESIGNER SERIES CONGAS - DEEP SEA

The new NINO® Deep Sea Designer Series Congas make a splash! Friendly fish characters send a positive message about making music and having fun together.

## 5. NINO910 WOOD CONGA SET

The NINO910 Wood Congas are ideal for first time players or schools. Height adjustable stands included.

## 6. NINO® CONGA BAG

The NINO® Conga Bag is designed to supply reliable protection while transporting the instrument. It holds congas up to 10" diameter.

**NEW!**

The rounded rim offers perfect playing comfort without harming the wrist or palm



**NINO910NT**

NINO® Wood Congas are equipped with strong tuning brackets

Height adjustable



**MNCOB**

**Size** Up to 10"  
**Material** Padded nylon  
**Features** External pocket  
Shoulder strap  
Carrying grip

**Sizes** 9" & 10"  
28" tall  
**Material** Rubber Wood (Hevea brasiliensis Muell.-Arg.)  
**Features** Hand selected buffalo heads  
Rounded rims for playing comfort  
Black powder coated hardware  
**Includes** Height adjustable basket stands with quick set up system  
Tuning key  
**Colour** NT = Natural



**NINO89NT**

**Sizes** 8" & 9"  
22" tall  
**Material** Rubber Wood (Hevea brasiliensis Muell.-Arg.)  
**Features** Hand selected buffalo heads  
Rounded rims for playing comfort  
Black powder coated hardware  
**Includes** Basket stands  
Tuning key  
**Colour** NT = Natural

**NINO89F-HK**

**Sizes** 8" & 9"  
22" tall  
**Material** Premium fiberglass  
**Features** Hand selected buffalo heads  
Rounded rims for playing comfort  
Black powder coated hardware  
**Includes** Basket stands  
Tuning key  
**Colour** HK = Harlekin®

# Congas

# Bongos



**Sizes** 6 1/2" & 7 1/2"  
**Material** Rubber Wood  
*(Hevea brasiliensis Muell.-Arg.)*  
**Features** Hand selected buffalo heads  
 Rounded rims for playing comfort  
**Includes** Tuning key  
**Colours** NT-BK = Natural Shell/  
 Black Hardware  
 NT-HK = Natural Shell/  
 Harlekin® Hardware

NINO3NT-BK

NINO3NT-HK

2.



NINO17R-BK

NINO17B-BK

**NEW!**

**Sizes** 6 1/2" & 7 1/2"  
**Material** ABS plastic  
**Features** Hand selected buffalo heads  
 Rounded rims for playing comfort  
 Black powder coated hardware  
**Includes** Tuning key  
**Colours** B-BK = Blue Shell/Black Hardware  
 R-BK = Red Shell/Black Hardware

The tuning system is outstanding in this price range

## 1. WOOD BONGOS

The NINO® Wood Bongo is an affordable yet high quality instrument with great versatility in sound. Children love the coloured Harlekin® design!

## 2. ABS BONGOS PLUS

A real alternative! The NINO® ABS Bongo Plus is an affordable bongo with a great sound and functional hardware. Shells made of ABS plastic make this bongo lighter than comparable wood models.

## 3. BONGO STAND

The NINO® Bongo Stand has been developed especially for kids and their height in order to offer them a safe and comfortable playing position. It can be tilted in a 90° angle and height adjusted from 31" up to 45" so children can play standing up or sitting down. The NINO® Bongo Stand is also suitable for many other common bongo models.

## 4. NINO® BONGO BAG

The NINO® Bongo Bag is designed to supply reliable protection while transporting the instrument.



NINO20

The latch of the Bongo Stand holds the bongo absolutely stable

**Material** Chrome plated steel  
**Features** Fully height adjustable  
 from 31" to 45"  
 90° angle adjustable  
 Tripod stand with rubber feet  
 Suitable for other common bongo models

4.



MNBB

**Material** Padded nylon  
**Features** Padded shoulder strap  
 Carrying grip  
 Reinforced bottom

# Cajons

**Sizes** Length 9.5" (24 cm)  
 Height 13" (33 cm)  
 Depth 10" (25.4 cm)  
 Weight 5.5 pds  
 (2.500 gr)

**Materials** Frontplate: Makah-Burl  
 Resonating Body: Rubber Wood  
*(Hevea brasiliensis Muell.-Arg.)*

**Features** Adjustable sizzle effect  
 Anti-slip sitting surface  
 Adjustable top corners

**Includes** Allen wrench

Adjustable sizzle effect

Makah-Burl

Heavy duty rubber feet for a solid base

2.



NINO524DS

**NEW!**

**Material** Eco-friendly medium density fiberboard with applique graphics

**Feature** Internal snare wires  
 Anti-slip sitting surface  
 Adjustable top corners

**Colour** DS = Deep Sea  
**Finish** Matte

Internal snare wires

Eco-friendly medium density fiberboard with applique graphics



NINO31

**Sizes** 12" x 5.5" x 5"  
**Material** Rubber Wood  
*(Hevea brasiliensis Muell.-Arg.)*  
**Feature** High- and low pitch playing surface

**NEW!**

Carrying grip

**Material** Padded nylon  
**Features** Padded shoulder strap  
 Carrying grip

MNCJB

4.



## 1. CAJON

The NINO® Cajon delivers the classic sound and due to its smaller dimension, it is especially suitable for a children. It is made from high quality materials ensuring long lasting life for this delightful instrument. Not just for children, professional players may find the NINO® Cajon interesting, as they add a different yet authentic Cajon sound to their arsenal of instruments.

## 2. NINO® DESIGNER SERIES CAJON - DEEP SEA

The new NINO® Deep Sea Designer Series Cajon is a full sounding cajon decorated with a collection of friendly fish. It's an inviting way to get started with music!

## 3. BONGO CAJON

The new NINO® Bongo Cajon is a great sounding cajon in a size suitable for children. The playing surface is divided into two sections, for high and low pitches, just like traditional bongo drums. It can be held between the knees, or set on the floor.

## 4. NINO® CAJON BAG

The NINO® Cajon Bag is designed to supply reliable protection while transporting the instrument.

# Bongos, Cajons

Pure creativity



Children paint music -  
an unadulterated impression of  
creativity.



When it comes to arts and music, children show an approach to the subject which most adults lost long ago. In search of the child in us, we visited kindergartens and asked young artists to express through paintings what music means to them.

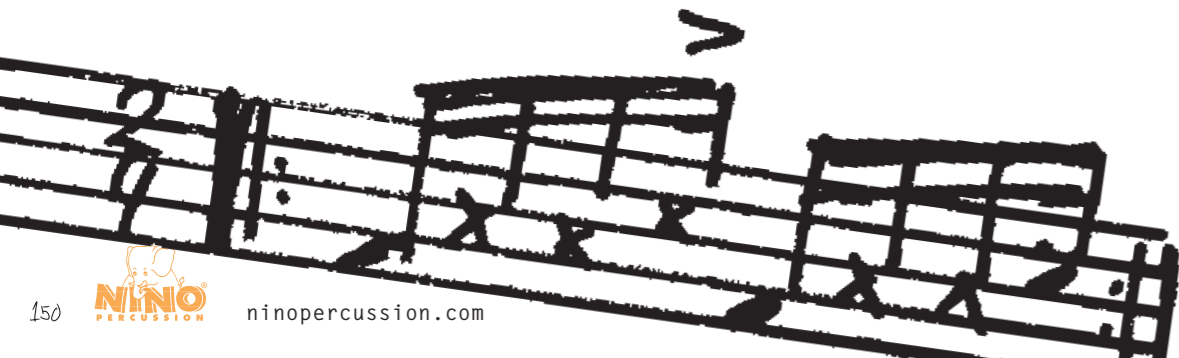

# Frame Drums



Sizes 10", 12", 14"  
Materials Plastic head  
Wooden frame

1. WOOD HAND DRUMS  
The NINO® Wood Hand Drums are equipped with synthetic heads that are firmly attached on a scalloped wooden frame. These nice sounding drums are light in weight and a proper instrument for children in kindergartens.

2. FRAME DRUMS  
These NINO® Frame Drums are traditionally equipped with buffalo skin heads and come with a wooden beater. With their warm tone they can be used in various musical occasions.

3. SEA DRUM  
The NINO® Sea Drum has hundreds of tiny metal balls enclosed between two clear mylar heads. By holding the drum horizontally and gently rolling it, you create the sounds of the ocean surf.

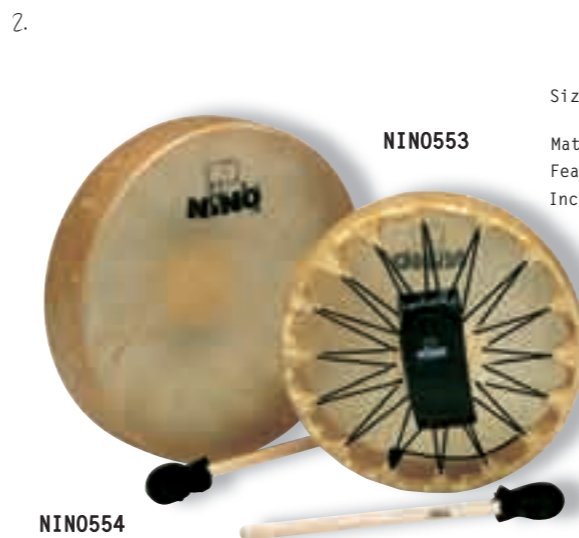

Sizes NIN0553 = 12 1/2"  
NIN0554 = 15"  
Material Buffalo skin heads  
Feature Velcro strap  
Includes Wooden beater



Size 14"  
Materials Rubber Wood  
(*Hevea brasiliensis* Muell.-Arg.)  
Two clear synthetic heads  
Feature Soothing sounds

Soothing sounds

NEW!

Frame Drums

# Hand Percussion

## 1. WOOD TAMBOURINES

The NINO® Wood Tambourines feature a sturdy wooden frame along with a nice sparkling sound. They are available in a one row construction with 8 nickelsilver plated steel jingle pairs, or as a two row model with 16 nickelsilver plated steel jingle pairs.



**Size** 10" diameter  
**Materials** Jingles: Nickelsilver plated steel  
 Wooden frame  
**Feature** 1 or 2 row versions available

## 2. RACKET TAMBOURINE

The NINO® Racket Tambourine features a sturdy rattan frame along with a nice sparkling sound. It is available as a one row construction with 9 aluminum jingle pairs. An ergonomically shaped handle makes it perfect for children hands.



**Materials** Frame: Rattan  
 Jingles: Aluminum  
**Features** Ergonomically shaped and padded handle

## 3. HEADED WOOD TAMBOURINES

With nickelsilver plated steel jingles and plastic heads firmly attached to the tambourine, this instrument delivers a subtle and gentle tone.



**Size** 10" diameter  
**Materials** Jingles: Nickelsilver plated steel  
 Plastic heads  
 Wooden frame  
**Feature** 1 or 2 row versions available

## 4. A-GO-GO BELL

The NINO® A-Go-Go Bell is perfectly sized for children. It is handmade from high quality steel and produces a loud bell sound.



**Material** Black powder coated steel

## 5. TRIANGLES

NINO® Percussion offers three tonally matched triangles. Each have a strong sound with a long sustain.



**Sizes** 4"  
 6"  
 8"  
**Material** Steel  
**Feature** Wooden holder with braided nylon strap  
**Includes** Metal beater with rubber padded grip

## 6. CABASAS

The NINO® Cabasas are made from a wooden cylinder covered with a rippled metal plate, which is surrounded by a net of metal beads. Holding the handle with one hand and scratching the metal beads with the other hand on the metal plate creates the classic cabasa sound. The smaller 2" model was especially designed for a child's hand.

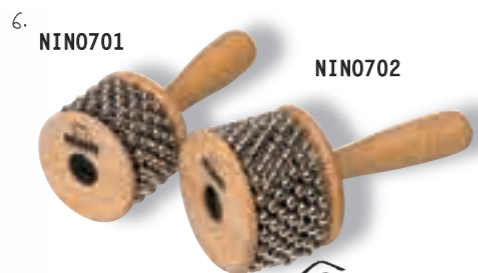

**Sizes** Small  
 Medium  
**Material** Steel chain and cylinder  
**Feature** Ergonomically shaped wooden handle

*Fine sizzle sound*



**Size** 12 bars  
**Material** Silver anodized aluminum alloy

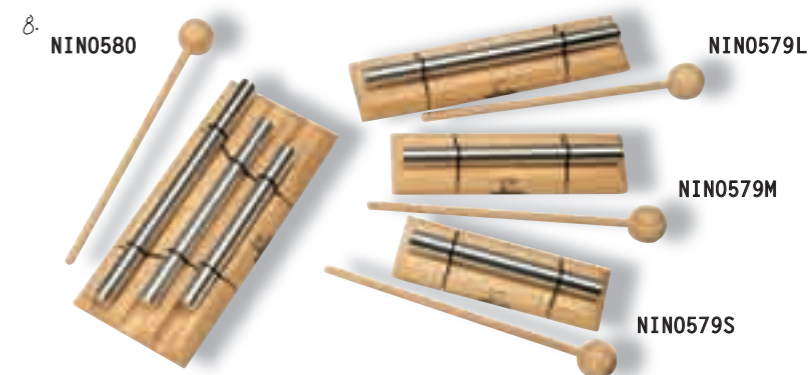

**Sizes** Small  
 Medium  
 Large  
 3 rows  
**Material** Silver anodized aluminum alloy  
**Includes** Wooden beater

## 7. CHIMES

The NINO® Chimes can be mounted on a cymbal stand, or held by the wooden frame. The 12 bars of the NINO® Chimes are made from a premium aluminum alloy and create a very full and rich sound.

## 8. ENERGY CHIMES

These NINO® instruments have a very cutting "ping" sound. The free floating bars create a very long sustain. NINO® offers three different pitched Energy Chimes, as well as a model with three bars.

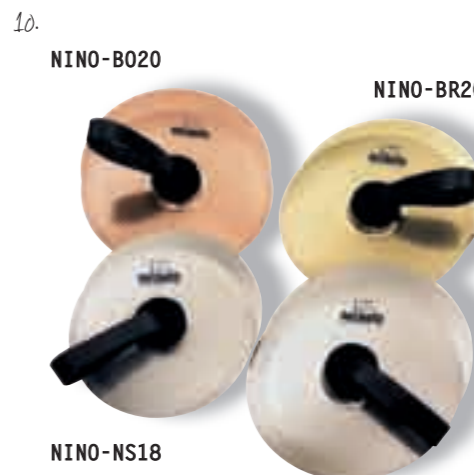

**Sizes** 7"/17.5 cm  
 8"/20.0 cm  
**Materials** Bronze, brass, or nickel silver  
**Includes** Leather straps

## 9. HAND CHIMES

With bars made from a silver anodized aluminum alloy, the NINO® Hand Chimes produce a full and rich sound.



**Size** 12 bars  
**Material** Silver anodized aluminum alloy

## 10. CYMBAL PAIRS

NINO® Cymbal Pairs are made in Germany from premium alloys. Different sizes are available in bronze, brass, or nickel silver. All cymbal pairs are tonally matched and are equipped with a leather strap.

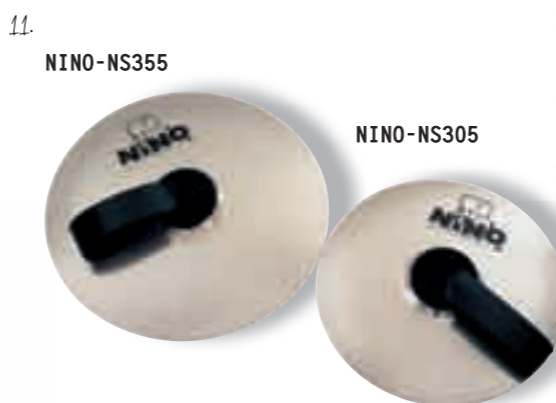

**Sizes** 12"/30.5 cm  
 14"/35.5 cm  
**Material** Nickel silver  
**Includes** Leather strap

## 11. CYMBALS

These excellent sounding NINO® Cymbals are made in Germany. They are a high quality product and perfect for music education.



Hand Percussion

# Hand Percussion



NINO13BK

NINO13R

NINO13Y

**Materials** Jingles: Nickelsilver plated steel  
Frame: ABS

**Features** Ergonomically shaped handle  
New sound ideas

**Colours** BK = Black  
R = Red  
Y = Yellow

## 1. JINGLE STICKS

The NINO® Jingle Sticks feature six pairs of nickelsilver plated jingles firmly mounted on a plastic frame with a handle. The jingle stick can be played like a tambourine, or like a drumstick on a conga, bongo, or djembe. New and interesting sounds can be achieved with this instrument.

## 2. PLASTIC MARACAS

The NINO® Plastic Maracas are known for their stability, versatility, and strong, projecting sound.

## 3. MINI GUIROS

The NINO® Mini Guiros are made from high quality material. The sound is achieved by scratching the different surfaces of the guiro.



NINO582GR

NINO582R

NINO582Y

**Material** Plastic  
**Features** Ergonomically shaped handle  
Sold as pairs

**Colours** GR = Green  
R = Red  
Y = Yellow



NINO581BK

NINO581R

**Size** Mini  
**Includes** Wooden scraper  
**Colours** BK = Black  
R = Red



NINO565

NINO566

**Sizes** Small  
Medium  
**Material** Rubber Wood  
(*Hevea brasiliensis* Muell.-Arg.)  
**Features** Ergonomically shaped handle  
Sold as pairs



NINO569R

**Size** 6"  
**Material** Plastic  
**Features** Ergonomically shaped handle  
Sold as pairs  
**Colour** R = Red

## 4. WOOD EGG MARACAS

Maracas are used for any style of music and are one of the most popular rhythm instruments worldwide. The NINO® Wood Egg Maracas have a nice warm sound and come with an ergonomically shaped handle.

## 5. PLASTIC EGG MARACAS

The NINO® Egg Maracas are made from a special plastic material. They have a very clear and pronounced sound and are perfect maracas for children.

## 6. WOOD MARACAS

The NINO® Wood Maracas sound very focused and have more attack.

## 7. RAWHIDE MARACAS

NINO® Rawhide Maracas are entirely hand made and have a warm and mellow sound.

## 8. RAWHIDE EGG SHAKER

The NINO® Rawhide Egg Shaker is entirely hand made and has a warm and mellow sound.

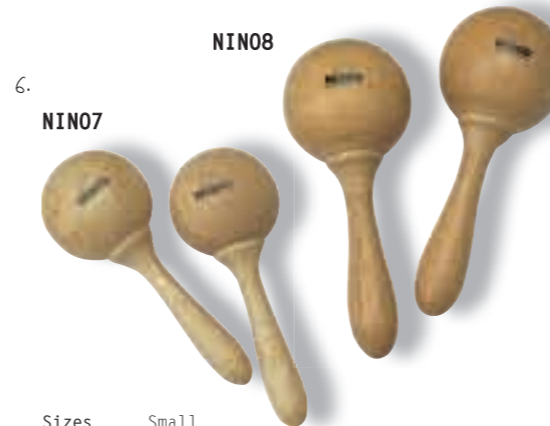

NINO7

NINO8

**Sizes** Small  
Medium  
**Material** Rubber Wood  
(*Hevea brasiliensis* Muell.-Arg.)  
**Features** Ergonomically shaped handle  
Sold as pairs



NINO10

**Size** Small  
**Material** Natural rawhide  
**Features** Mellow sound  
Ergonomically shaped wood handle  
Sold as pairs



NINO11

**Material** Natural rawhide



# Hand Percussion



**Sizes** Small  
Medium  
Large  
X-large

**Material** Wood

**Feature** Creates original "ribbit" sound

**Includes** Wooden scratcher

**Colour** GR = Green

## 1. WOOD FROGS

The NINO® Wood Frogs have gained an enormous popularity over the last few years. Children especially love the authentic "ribbit" sound which is created by scratching the wooden beater on the frog's back. Great fun for kids and adults.

## 2. WOOD SHAKERS

Toddlers especially love these little rhythm instruments. NINO® Natural Wood Shakers have different fillings. A cylindrical shaped shaker is available in two different sizes, as well as a square, and a triangular shaped shaker assortment.

## 3. WOOD ANIMALS

The NINO® Wood Animals are great sounding miniature imitations of a grasshopper, snail, turtle and pig. Scratching the wooden beater on the surface of the instruments creates a nice guiro-like sound. Great fun for kids and adults.

## 4. WOOD EGG SHAKERS

NINO® Wood Egg Shakers are very handy because of their shape. They also have a great sound with various pitches depending on their size.



**NEW!**

**NEW!**

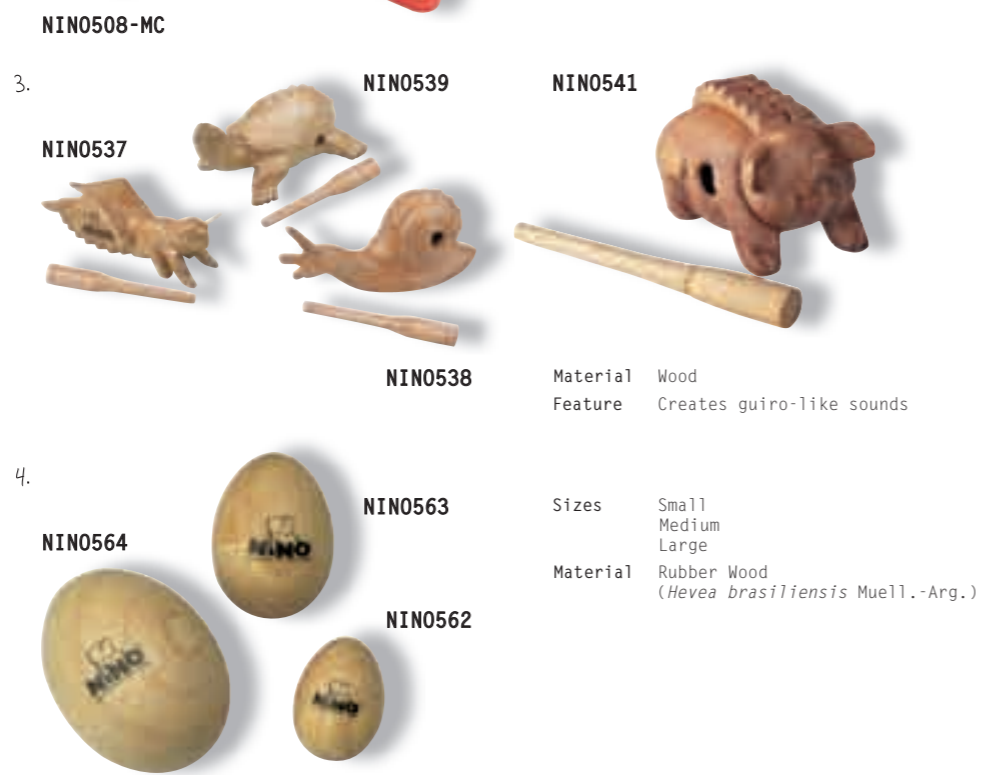

**Shapes** NIN01 = Cylindrical, small  
NIN02 = Cylindrical, large  
NIN0507-MC = Square, 3 pcs. set  
NIN0508-MC = Triangular, 3 pcs. set

**Material** Rubber Wood  
(*Hevea brasiliensis* Muell.-Arg.)

**Feature** Different sounding fillings

**Colour** MC = Multi color

**Material** Wood

**Feature** Creates guiro-like sounds

**Sizes** Small  
Medium  
Large

**Material** Rubber Wood  
(*Hevea brasiliensis* Muell.-Arg.)

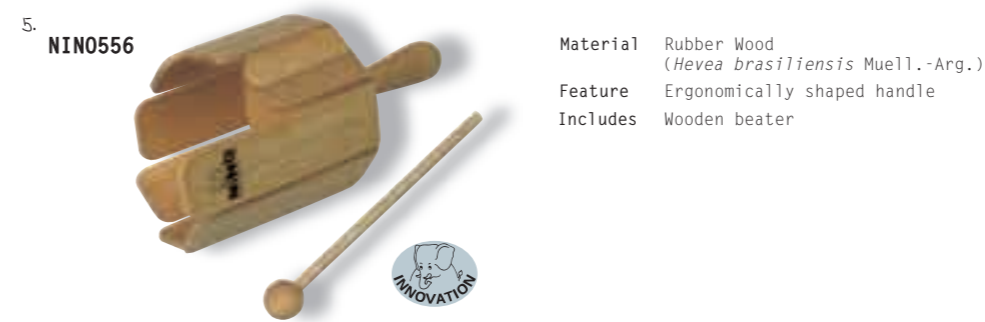

**Material** Rubber Wood  
(*Hevea brasiliensis* Muell.-Arg.)

**Feature** Ergonomically shaped handle

**Includes** Wooden beater

**5. WOOD STIRRING DRUM**

The eight wooden tongues produce different pitches when they are struck separately, like playing a xylophone. By stirring in the drum with the included beater a scale can be played.

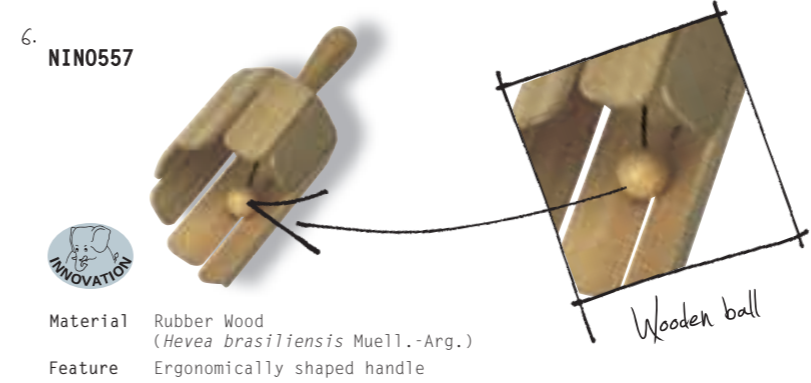

**Material** Rubber Wood  
(*Hevea brasiliensis* Muell.-Arg.)

**Feature** Ergonomically shaped handle

**6. WOOD BALL STIRRING DRUM**

The NINO® Wood Ball Stirring Drum is a further development of the familiar stirring drum. When playing the drum, a wooden ball fastened to a nylon string strikes the tonally matched wooden tongues and produces a harmonic sound.

**7. WOOD HAND CASTANETS**

The NINO® Wood Hand Castanets are a fun way to make rhythm. Solid wood construction assures good sound and safe play.

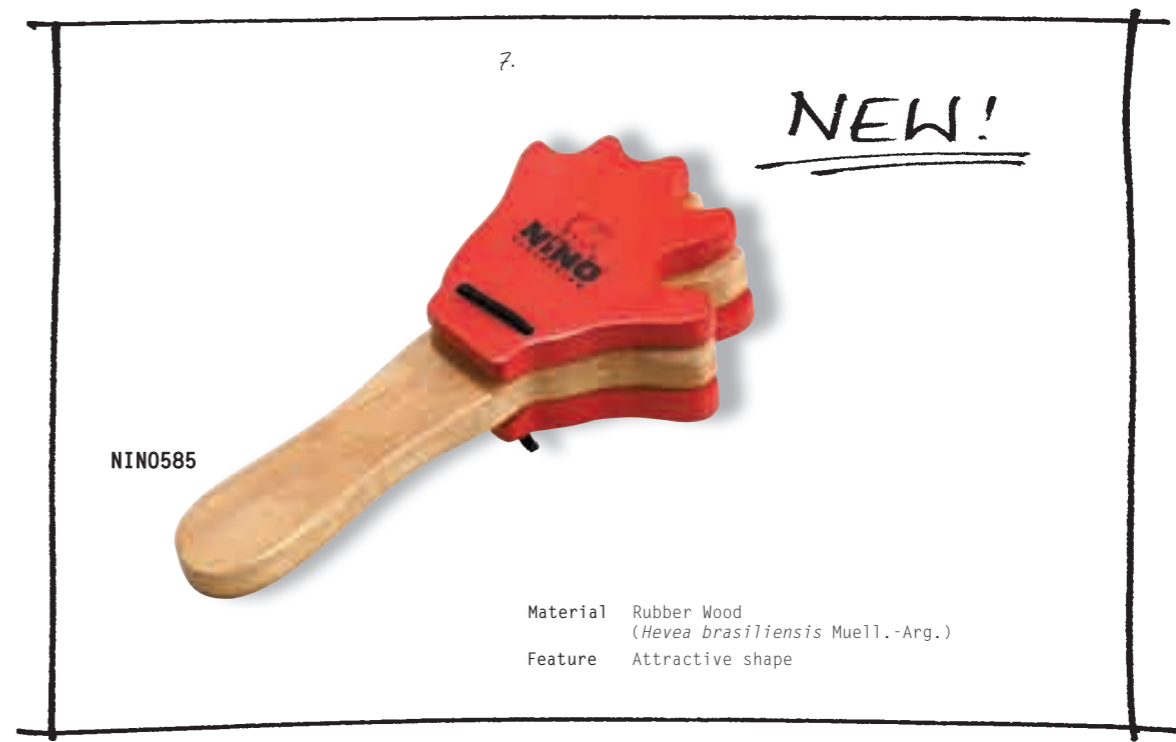

**Material** Rubber Wood  
(*Hevea brasiliensis* Muell.-Arg.)

**Feature** Attractive shape

**NEW!**



# Hand Percussion

## 1. WOOD CLAVES

Claves are an essential instrument in Latin music and shouldn't be missing from any percussion set up. The NINO® Wood Claves are available as regular sized models. A second pair was especially designed to fit a child's hand size.

## 2. WOOD BLOCKS

The Wood Block is probably one of the oldest rhythm instruments and should be part of any percussion group. The NINO® Wood Blocks have an impressive sound and are available in two sizes.

## 3. WOOD A-GO-GO'S

The NINO® Wood A-go-go's are played with a wooden beater and produce a powerful sound. They can also be scratched like a guiro. These two playing styles leave room for creativity.

## 4. WOOD TONE BLOCK

The NINO® Wood Tone Block has two tonally matched resonant chambers in the solid wooden body.

## 5. ORIENTAL WOOD TONE BLOCK

The NINO® Oriental Wood Tone Block produces a high pitched and open sound.

**Material** Rubber Wood  
(*Hevea brasiliensis* Muell.-Arg.)  
**Feature** Tonally matched resonating bodies  
**Includes** Wooden beater



**NINO572**  
**Material** Rubber Wood  
(*Hevea brasiliensis* Muell.-Arg.)  
**Feature** Ergonomically shaped handle  
**Includes** Wooden beater

1.

**NIN0502**



**NIN0574**



**Sizes** Small  
Regular  
**Material** Rubber Wood  
(*Hevea brasiliensis* Muell.-Arg.)  
**Feature** Sold as pairs

2.

**NIN022**

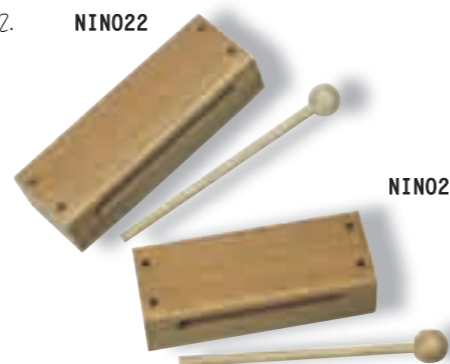

**NIN021**

**Sizes** Medium  
Large  
**Material** Rubber Wood  
(*Hevea brasiliensis* Muell.-Arg.)  
**Includes** Wooden beater

3.

**NIN0561**

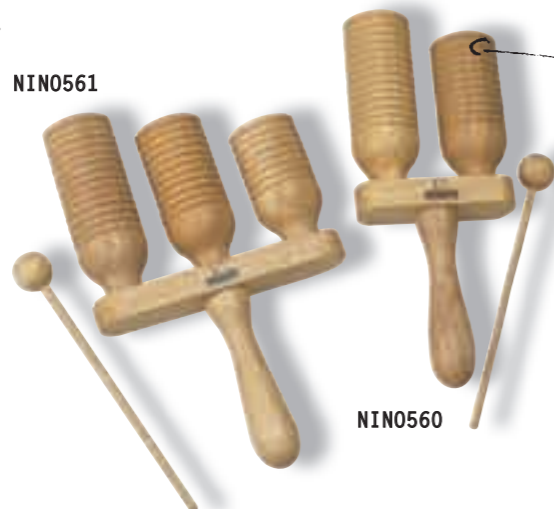

*Guiro effect*

**Sizes** 2 rows  
3 rows  
**Material** Rubber Wood  
(*Hevea brasiliensis* Muell.-Arg.)  
**Features** Different playing options  
Ergonomically shaped handle  
**Includes** Wooden beater

**NIN0560**

4.

**NIN0570**



**NIN0571**

**NEW!**

*Tonally matched*

6.

**NIN0555**

**Material** Rubber Wood  
(*Hevea brasiliensis* Muell.-Arg.)  
**Includes** Wooden striker

8.

**NIN0520**

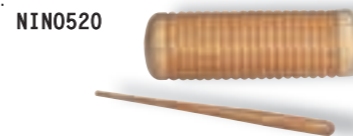

9.

**NIN0521**



**NIN0522**



10.

**NIN0501**

**Materials** Rattan with natural skin hide bottom

7.

**NIN0519**

**Material** Rubber Wood  
(*Hevea brasiliensis* Muell.-Arg.)

**Material** Rubber Wood  
(*Hevea brasiliensis* Muell.-Arg.)  
**Feature** Additional shaker sound  
**Includes** Wooden striker

**Sizes** Small  
Medium  
**Materials** Rattan with coconut bottom

11.

**NIN0503**

**Materials** Rattan with natural skin hide bottom

## 6. WOOD GUIRO

The guiro is an instrument which plays a very important part in any percussion set up. Striking the tonal grooves of the NINO® Wood Guiro creates many different sounds.

## 7. WOODPECKER

The NINO® Woodpecker creates an amazingly realistic "woodpecker" sound. It's a great effect instrument which is also interesting for professional players who look to increase their sound arsenal.

## 8. WOOD GUIRO SHAKER

The NINO® Wood Guiro Shaker is equipped with a filling and combines a shaker as well as a guiro sound in one instrument.

## 9. GANZA SHAKERS

The NINO® Ganza Shakers produce a voluminous sound due to their size.

## 10. CAXIXI

The NINO® Caxixi produces a clear and cutting sound.

## 11. DOUBLE SHAKER

The NINO® Double Shaker produces a clear and cutting sound with enhanced volume.



# Shakers

## BOTANY SHAKERS

The NINO® Botany Shakers are made from a high quality plastic material filled with a specially nice sounding substance. These fruit and vegetable imitations look amazingly real and create a great variety of sounds. NINO® Botany Shakers have been tested for saliva resistance.

1. "FRUIT" ASSORTMENT  
4 pcs.
2. "VEGETABLE" ASSORTMENT  
4 pcs.
3. BOTANY SHAKER ASSORTMENT  
36 pcs.

1.

### NINOSSET100

Material Plastic  
Feature Botany Shaker Assortment, 4 pcs. "fruit"

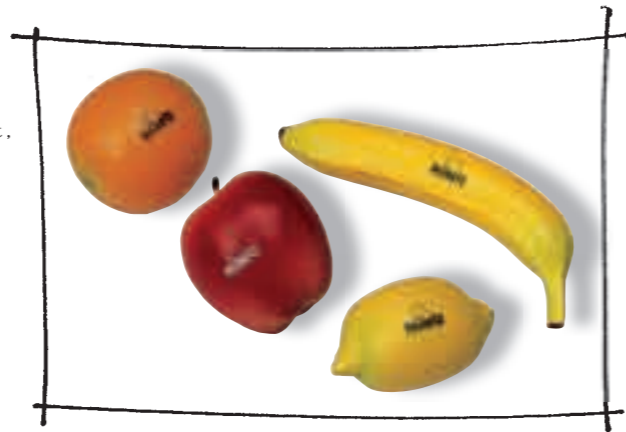

2.

### NINOSSET101

Material Plastic  
Feature Botany Shaker Assortment, 4 pcs. "vegetable"



3.

### VE36-NIN0536

Material Plastic  
Feature Botany Shaker Assortment, 36 pcs. incl. 2 baskets of each 18 pcs.



4.

### NIN0540LB

### NIN0540LGR

### NIN0540LR

### NIN0540LBK

### NIN0540LY



Material Plastic  
Colours B = Blue  
BK = Black  
GR = Green  
R = Red  
Y = Yellow

## 4. EGG SHAKERS

NINO® Egg Shakers are vital to every percussion collection. They have an extremely pronounced and crystal clear sound.

5. ASSORTMENT, 4 pcs.
6. ASSORTMENT, 80 pcs.

5.



### NINOSSET540

Material Plastic  
Sets Egg Shaker Set 4 pcs.  
Egg Shaker Set 80 pcs. including elephant shaped basket

6.

### VE80-NIN0540



7.

### NIN0509



Material Plastic  
Feature Attractive Harlekin® design

## 7. BALL SHAKER

The two shakers are firmly attached to each other with a strong cord. By tightly holding one ball and rhythmically swinging the other one, many sounds can be achieved.



# Nino® Sets

NINO® instruments have been designed to meet the demands of early childhood education and are perfectly suitable for the use in kindergartens, schools, music therapy and musical activities in the family. Available are two different NINO® Percussion collections which come in a durable nylon Harlekin® design bag. It's the perfect activity for small groups of up to 8 children.



NINOSET1



NINOSET4



NINO800HK

NINO800R

Material Nylon  
 Feature Many compartments  
 Colours HK = Harlekin®  
 R = Red

## 1. NINOSET1

Contents:  
 1 x ABS Hand Drum 6"  
 1 x Wooden Beater  
 1 x Wood Shaker, large  
 1 x Skin Maracas pair, small  
 1 x Jingle Stick  
 1 x Harlekin® bag

## 2. NINOSET4

Contents:  
 1 x Wood Guiro  
 1 x Caxixi  
 1 x Wood Claves pair, small  
 1 x Triangle, 4"  
 1 x Egg Shaker  
 1 x Egg Shaker, small  
 1 x Botany Shaker, Banana  
 1 x Botany Shaker, Apple  
 1 x Harlekin® bag

## 3. MUSIC BAGS

Handy bags made from durable nylon are always useful. These NINO® Music Bags are available in red and the Harlekin® design. Many separate compartments make them ideal for all kind of activities.



# Nino® Rhythm Sets

These two NINO® Rhythm Sets include 12 or 15 individual instruments. They are perfect for use in kindergarten, schools, or percussion groups. These collections of different instruments are the ideal way to explore the complete NINO® world of percussion and rhythm.

## 1. RHYTHM ASSORTMENT, 12 pcs.



NINOSET012

## 1. RHYTHM ASSORTMENT, 12 pcs.

Contents:  
 1 x ABS Hand Drum 12"  
 1 x ABS Tambourine 10"  
 1 x ABS Hand Drum 8"  
 1 x ABS Hand Drum 6"  
 1 x Skin Maracas pair, medium  
 1 x Wood Block, large  
 1 x Skin Egg Shaker  
 1 x Jingle Stick, yellow  
 1 x Jingle Stick, red  
 1 x Wood Tambourine, 10"  
 1 x Wood Shaker, small

## 2. RHYTHM ASSORTMENT, 15 pcs.

Contents:  
 1 x Wood Guiro  
 1 x Triangle, 6"  
 1 x Plastic Egg Maracas pair, red  
 1 x Mini Guiro  
 1 x Egg Shaker  
 1 x Racket Tambourine  
 1 x Wood Claves pair, small  
 1 x Energy Chimes, medium  
 1 x Wood A-Go-Go, 2 rows  
 1 x Double Shaker  
 1 x Wood Shaker Assortment 3 pcs., triangular  
 1 x Botany Shaker, Banana  
 1 x Basket

## 2. RHYTHM ASSORTMENT, 15 pcs.



NINOSET515



# ABS Drums

The colourful NINO® ABS Drums are not only durable, they also have a powerful sound. Shells made from ABS plastic and synthetic heads guarantee great stability and a long life. With their low weight of about two pounds and their outstanding workmanship.



The drums come pretuned and ready to play right out of the box

Size 8"  
Material ABS plastic  
Feature Synthetic heads  
Includes Nylon strap  
Colours B = Blue  
G/Y = Green/Yellow  
R/BK = Red/Black  
R = Red

NINO18R/BK NINO18R NINO18B NINO18G/Y

## 1. ABS DJEMBES

The multi-coloured NINO® ABS Djembes come pretuned and ready to play right out of the box.

## 2. ABS BONGOS

The NINO® ABS Bongos are light weight and are perfect instruments for children in kindergarten or elementary school.



NINO19G/Y

NINO19B



NINO19R/BK

NINO19R

Sizes 6 1/2" & 7 1/2"  
Material ABS plastic  
Feature Synthetic heads  
Colours B = Blue  
G/Y = Green/Yellow  
R/BK = Red/Black  
R = Red



NINO6BK NINO6Y NINO6GR NINO6B NINO6R

NINO5BK NINO5Y NINO5GR NINO5B NINO5R



NINO45BK NINO45GR NINO45B NINO45R  
NINO45Y NINO45B



NINO4BK NINO4GR NINO4R  
NINO4Y NINO4B

Sizes NINO4 = 6"  
NINO45 = 8"  
NINO5 = 10"  
NINO6 = 12"  
Material ABS plastic  
Feature Synthetic heads

Includes Wooden beater  
Colours B = Blue  
BK = Black  
GR = Green  
R = Red  
Y = Yellow

The drums come pretuned and ready to play right out of the box !!!



NINO24BK NINO24R NINO24B NINO24GR NINO24Y

Size 10"  
Materials ABS plastic with nickelsilver jingles  
Feature Synthetic heads  
Includes Wooden beater

Colours B = Blue  
BK = Black  
GR = Green  
R = Red  
Y = Yellow

## 3. ABS HAND DRUMS

The multi-coloured NINO® ABS Hand Drums offer more than just tonal variety. The unbreakable shells and durable synthetic heads ensure years of trouble-free use.

## 4. ABS TAMBOURINES

The NINO® ABS Tambourines offer enhanced sound options due to attached jingle pairs.



ABS Drums

# Djembes



NINO-ADJ2-XXS NINO-ADJ2-S

**NINO-ADJ2-XXS**  
**NINO-ADJ2-XS**  
**NINO-ADJ2-S**

**Material** Mahogany Wood  
**Features** Carved from one solid piece of plantation grown Mahogany Wood  
 Hand selected goat heads  
 High quality PP nylon ropes  
 Hand carved shells  
**Colour** Brown

Sizes	Diameter	Tall
XXS = 4 1/2"	4 1/4" - 4 3/4"	8"
XS = 7"	6 1/4" - 8 1/4"	11 3/4"
S = 8"	7" - 8 1/2"	15 3/4"

PP rope	Thickness	Runners
XXS	3 mm	10
XS	3 mm	20
S	4 mm	20

## ORIGINAL AFRICAN STYLE ROPE TUNED WOOD DJEMBES

The NINO® Original African Style Rope Tuned Wood Djembes are carved from one solid piece of plantation grown Mahogany Wood. These high quality instruments are crafted with great attention to detail and provide an outstanding sound.

1. WATER RHYTHM SERIES
2. EARTH RHYTHM SERIES
3. MOON RHYTHM SERIES



NINO-ADJ3-XXS NINO-ADJ3-S

**NINO-ADJ3-XXS**  
**NINO-ADJ3-XS**  
**NINO-ADJ3-S**

**Material** Mahogany Wood  
**Features** Carved from one solid piece of plantation grown Mahogany Wood  
 Hand selected goat heads  
 High quality PP nylon ropes  
 Hand carved shells  
**Colour** Brown/Black

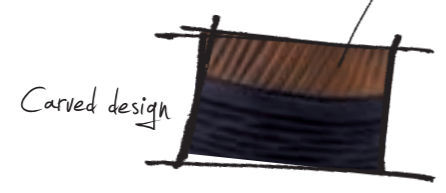

NINO-ADJ4-XXS NINO-ADJ4-S

**NINO-ADJ4-XXS**  
**NINO-ADJ4-XS**  
**NINO-ADJ4-S**

**Material** Mahogany Wood  
**Features** Carved from one solid piece of plantation grown Mahogany Wood  
 Hand selected goat heads  
 High quality PP nylon ropes  
 Hand carved shells  
**Colour** Black



NINO23NT

**Size** 10"  
 21" tall  
**Material** Rubber Wood  
 (Hevea brasiliensis Muell.-Arg.)  
**Features** Hand selected goat head  
 Rounded rim for playing comfort  
 Black powder coated hardware  
 Floatune Tuning System  
**Includes** Tuning key  
**Colour** NT = Natural

## 4. WOOD DJEMBE

The Djembe is the most popular African drum. Even first time players are quickly able to draw different tones from this great instrument. The NINO® Wood Djembe has a diameter of 10" and a height of 21" and is the perfect drum for children in kindergarten or elementary school.

## 5. NINO® DJEMBE BAG

The NINO® Djembe Bag is designed to supply reliable protection while transporting the instrument. It holds djembes up to 10" diameter.



MNDJB

**Size** Up to 10"  
**Material** Padded nylon  
**Features** External pocket  
 Shoulder strap  
 Carrying grip



# Shake'n Play

The NINO® Shake'n Play is a sound-based memory game for two to four children ages three years and up, and fun for the entire family. Sixteen identical shakers make eight matched pairs. The object of the game is to find the pairs by remembering the sounds and positions on the board. Shake'n Play is a good development game and certified child-proof by the LGA.



**FUN FOR THE ENTIRE FAMILY**



Images on bottom ensure correct match

Certified childproof by the LGA

NIN0526

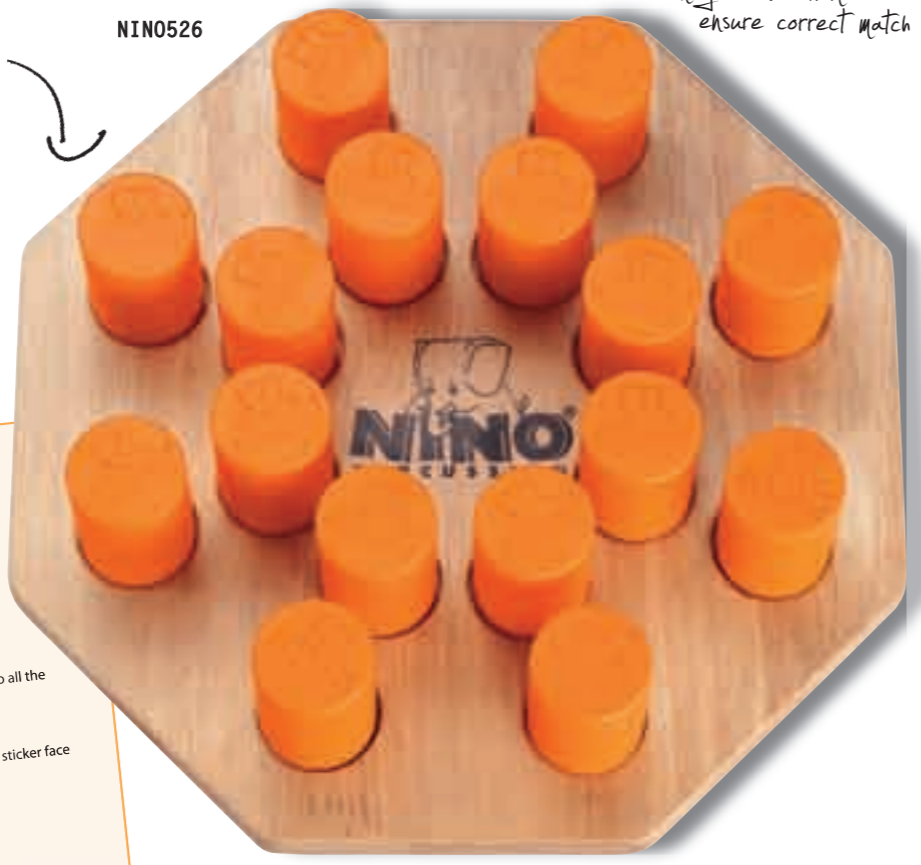

## SHAKE'N PLAY

game guide

**Who can find the most pairs?**  
 Type of game: Memory game  
 Contents: 16 shakers (8 pairs)  
 1 game board  
 1 game guide

**Advice for parents**  
 To begin, it is often helpful for young first-time players to listen carefully to all the sounds first, in order to identify the different tones.

**Setting up**  
 Before the game begins the 16 shakers are shuffled and placed, with the sticker face downwards on the game board.

**Aim of the game**  
 Every player tries to collect as many pairs as possible.

**How to play**  
 The youngest child begins by taking a shaker and shaking it so all players can hear the sound. Then a second shaker is selected and shaken and the two tones compared. If a correctly matching pair of shakers is found then the player may keep the shakers and may try their luck again. If the tones of the two selected shakers are different then the player replaces the shakers on the game board and the next player continues. To ensure that correct shaker pairs are found, each respective pair is marked on the underside with an instrument sticker. Any confusion is therefore impossible.

**End of game**  
 The game ends when there are no more shakers left on the game board. The winner is the player with the most shakers.

**Materials** Plastic shakers  
 Base out of Rubber Wood  
 (Hevea brasiliensis Muell.-Arg.)  
**Includes** 16 shakers (8 pairs)  
 Game guide (in 8 languages)  
 Wooden base  
**Colour** Orange



Game guide (in 8 languages)

# Glockenspiel

The NINO® Glockenspiel is a child-friendly way to start out with music. The jolly fish has colourful keys tuned to a scale of c d e f g a b c'. The keys may be removed for simplicity and later replaced as your child develops confidence. All corners are contained inside the rounded profile of the wooden body. The googly eye and flapping blue tail make the "Fish" Glockenspiel a charming and entertaining character!

Keys tuned to a scale of c d e f g a b c'



**Material** Body made out of Pine Wood  
 Removable colour-coded metal keys  
**Includes** Two wooden mallets  
 Songbook  
**Finish** Matte



# THE SAFETY !!!

NINO® instruments have been tested by the Landesgewerbeanstalt Bayern, Germany (LGA), Institute for the Testing of Goods and Quality Monitoring and have been awarded with the LGA Test Certificate.

This means that NINO® instruments comply with the strict requirements of the European Community Directives 88/378EC and 87/357/EC.

## PRODUCT TESTING

All NINO® instruments are regularly tested for safety and sanitary harmlessness according to the EC Directives 88/378/EC (Toy Safety Directive) and 87/357/EC (Imitation of Food). The tests are carried out by the Landesgewerbeanstalt Bayern, Germany (LGA), a modern testing and consulting services organization with over 30 branches worldwide. As a recognized institute for the testing of goods and quality monitoring, the LGA is entitled to award the GS and LGA test marks which are accepted throughout Europe and internationally as a guarantee of safety.

## NINO® INSTRUMENTS PASS THE FOLLOWING TESTS

Testing in dependence on the Toy Safety Directive (88/378/EC)
Mechanical and physical characteristics
Inflammability
Migration of certain parts
Saliva and perspiration resistance
Colorfastness
Determination of the content of Pentachlorophenol (PCP)
Testing with regard to pesticides
Valuation in accordance with EC Directive 87/357/EC

## CERTIFICATION

After passing all tests, the internationally accepted LGA Test Certificate was awarded for all NINO® percussion instruments. This certificate vouches for quality and safety.

## MATERIAL & ECOLOGY

Wood is a raw material which is present in almost every part of our daily life. Trees are an important part of the complex eco-system while healthy forests are imperative for the Earth's atmosphere. Only Rubber Wood (*Hevea brasiliensis* Muell.-Arg.) is used for the making of NINO® percussion instruments. This wood fulfils the CITES regulations ("Convention on International Trade in Endangered Species of Wild Fauna and Flora") and originates from environmentally controlled forests from industrial wood plantations.



# Merchandise

Support your favourite percussion brand with the official MEINL swag. A selection of exclusive items made from the highest quality materials.

1. T-SHIRT
2. LONG SLEEVE W. RED ARMS
3. POLO SHIRT



4. TRAINING JACKET
5. T-SHIRT
6. HOOD SHIRT W. ZIPPER





# Merchandise

1. ARMY CAPS
2. SWEAT SHIRT
3. TRAINING JACKET



**NEW!**



Sizes S, M, L, XL, XXL  
 Colour Black  
 Front MEINL logo, small  
 Back MEINL logo, big



Sizes M, L, XL, XXL  
 Colour Black  
 Front MEINL logo, small  
 Back MEINL logo, big

**NEW!**



Sizes 24", 30"

4. BAR STOOL
5. BACKPACK
6. MOUSE PAD "CONGA HEAD"
7. LANYARD



# Spare Parts

Model No.	Size	Height	Material	Features	SPARE PARTS				
					Head	Rim	Lug	Bracket	Page
<b>Congas</b>									
<b>HEADLINER® SERIES WOOD CONGA SETS</b>									
HC512 (incl. basket stands)	11" + 12"	28"	✓		HHEAD11/HHEAD12C	HRIM11/HRIM12C	HCLUG	HCBRACKET-02	10/11
HC555 (incl. basket stands)	10" + 11"	28"	✓		HHEAD10/HHEAD11	HRIM10/HRIM11	HCLUG	HCBRACKET-02	8/9
<b>HEADLINER® DESIGNER SERIES CONGAS</b>									
HC10 (incl. basket stands)	10"	28"	✓		HHEAD10	HRIM10	HCLUG	HCBRACKET-02	12/13
HC11 (incl. basket stands)	11"	28"	✓		HHEAD11	HRIM11	HCLUG	HCBRACKET-02	12/13
HC12 (incl. basket stands)	12"	28"	✓		HHEAD12C	HRIM12C	HCLUG	HCBRACKET-02	12/13
<b>MARATHON® CLASSIC SERIES / DESIGNER SERIES</b>									
MCC11	11"	30"	✓	✓	TS-B-38	SSR-25	LUG-03	BRACKET-15	14-19
MCC1134	11 3/4"	30"	✓	✓	TS-B-39	SSR-26	LUG-03	BRACKET-15	14-19
MCC1212	12 1/2"	30"	✓	✓	TS-B-40	SSR-27	LUG-03	BRACKET-15	14-19
<b>ARTIST SERIES, Luis Conte</b>									
LC11	11"	30"	✓	✓	TS-B-52	TTR-28	LUG-03	BRACKET-20	20
LC1134	11 3/4"	30"	✓	✓	TS-B-53	TTR-29	LUG-03	BRACKET-20	20
LC1212	12 1/2"	30"	✓	✓	TS-B-54	TTR-30	LUG-03	BRACKET-20	20
<b>PROFESSIONAL SERIES</b>									
MP11	11"	30"	✓	✓	TS-B-34	SSR-22	LUG-01	BRACKET-14	22/23
MP1134	11 3/4"	30"	✓	✓	TS-B-35	SSR-23	LUG-01	BRACKET-14	22/23
MP1212	12 1/2"	30"	✓	✓	TS-B-36	SSR-24	LUG-01	BRACKET-14	22/23
<b>FIBERCRAFT SERIES / DESIGNER SERIES</b>									
FC11	11"	30"	✓	✓	TS-B-34	SSR-22	LUG-01	BRACKET-14	24-26
FC1134	11 3/4"	30"	✓	✓	TS-B-35	SSR-23	LUG-01	BRACKET-14	24-26
FC1212	12 1/2"	30"	✓	✓	TS-B-36	SSR-24	LUG-01	BRACKET-14	24-26
<b>FLOATUNE SERIES</b>									
FL10	10"	30"	✓	✓	TS-B-01	SSR-06	LUG-01		27
FL11	11"	30"	✓	✓	TS-B-03	SSR-07	LUG-01		27
FL12	12"	30"	✓	✓	TS-B-15	SSR-12	LUG-01		27
FL13	13"	30"	✓	✓	TS-B-21	SSR-15	LUG-01		27
<b>ARTIST SERIES, Mongo Santamaria</b>									
MSA11	11"	30"	✓	✓	TS-B-07	SSR-08	LUG-02	BRACKET-16	28
MSA1134	11 3/4"	30"	✓	✓	TS-B-11	SSR-10	LUG-02	BRACKET-16	28
MSA1212	12 1/2"	30"	✓	✓	TS-B-17	SSR-13	LUG-02	BRACKET-16	28
<b>WOODCRAFT SERIES</b>									
WC11	11"	30"	✓	✓	TS-B-44	TTR-23	LUG-01	BRACKET-14	29
WC1134	11 3/4"	30"	✓	✓	TS-B-45	TTR-24	LUG-01	BRACKET-14	29
WC1212	12 1/2"	30"	✓	✓	TS-B-46	TTR-25	LUG-01	BRACKET-14	29
<b>SPARE PARTS FOR STANDS</b>									
10" Basket for HC555					HSTAND10				8/9
11" Basket for HC555/HC512					HSTAND11				8-11
12" Basket for HC512					HSTAND12				10/11
Rubber Feet (set of 3 pcs.) for Steely-II Stand					STAND-35				30
Rubber Tops (set of 3 pcs.) for Steely-II Stand					STAND-21				30
Screw Set complete for Steely-II Stand, black					STAND-22				30
Screw Set complete for Steely-II Stand, chrome					STAND-23				30
Screw Set complete for Steely-II Stand, gold tone					STAND-24				30
Socket Screw (set of 2 pcs.) black					STAND-26				30
Socket Screw (set of 2 pcs.) chrome					STAND-27				30
Socket Screw (set of 2 pcs.) gold tone					STAND-28				30
<b>OTHER PARTS</b>									
Lug Oil					SPARE-09				
Conga Saver for 8mm Lugs (set of 6 pcs.)					CONGA-SAVER8				
Conga Saver for 10mm Lugs (set of 6 pcs.)					CONGA-SAVER10				
Tuning Key, 13mm + 14mm, L shaped, gold tone					KEY-01				
Tuning Key, 13mm + 14mm, L shaped, chrome					KEY-02				
Tuning Key, 14mm, chrome					KEY-03				
Tuning Key, 13mm, chrome					KEY-04				

Model No.	Size	Material	Features	SPARE PARTS					
				Head	Rim	Lug	Bracket	Page	
<b>Bongos</b>									
<b>HEADLINER® SERIES ABS BONGO / ACRYLIC BONGO</b>									
HB50	6 1/2"	✓			HHEAD6,5	RIM-NI3-65-BK	LUG-NIN03		34
HB50	7 1/2"	✓			HHEAD7,5	RIM-NI3-75-BK	LUG-NIN03		34
<b>HEADLINER® SERIES WOOD BONGOS / DESIGNER SERIES</b>									
HB100	6 3/4"	✓			HHEAD634W	HRIM634W	HBLUG		34-35
HB100	8"	✓			HHEAD8W	HRIM8W	HBLUG		34-35
<b>FREE RIDE SERIES FWB190 WOOD BONGOS / DESIGNER SERIES</b>									
FWB190	6 3/4"	✓			HEAD-38	SSR-18	LUG-22		36
FWB190	8"	✓			HEAD-39	SSR-19	LUG-22		36
<b>FREE RIDE SERIES FWB200 WOOD BONGOS</b>									
FWB200	6 3/4"	✓			HEAD-38	SSR-20	LUG-22		37
FWB200	8"	✓			HEAD-39	SSR-21	LUG-22		37
<b>FREE RIDE SERIES MINI WOOD BONGOS</b>									
FWB100	3 1/2"	✓			TS-B-31	SSR-16	LUG-19		37
FWB100	4 1/4"	✓			TS-B-32	SSR-17	LUG-19		37
<b>LUIS CONTE ARTIST SERIES WOOD BONGO</b>									
LC300	6 3/4"	✓			TS-C-13	TTR-31	LUG-22		38
LC300	8"	✓			TS-C-14	TTR-32	LUG-22		38
<b>FREE RIDE SERIES FWB300 WOOD BONGO</b>									
FWB300	6 3/4"	✓			TS-C-13	TTR-31	LUG-22		38
FWB300	8"	✓			TS-C-14	TTR-32	LUG-22		38
<b>FREE RIDE SERIES FFB200 FIBERGLASS BONGOS</b>									
FFB200	6 3/4"	✓			TS-B-50	SSR-34	LUG-23		39
FFB200	8"	✓			TS-B-51	SSR-35	LUG-23		39
<b>FREE RIDE SERIES FFB400 FIBERGLASS BONGOS / DESIGNER SERIES</b>									
FFB400	7"	✓			TS-C-02	SSR-02	LUG-07		39
FFB400	8 1/2"	✓			TS-C-03	SSR-04	LUG-07		39
<b>FREE RIDE SERIES FWB400 WOOD BONGO</b>									
FWB400	7"	✓			TS-C-02	SSR-02	LUG-07		40
FWB400	8 1/2"	✓			TS-C-03	SSR-04	LUG-07		40
<b>FREE RIDE SERIES COLLECTION WOOD BONGO</b>									
CS400	7"	✓			TS-C-02	SSR-02	LUG-07		41
CS400	8 1/2"	✓			TS-C-03	SSR-04	LUG-07		41
<b>FREE RIDE SERIES WOODCRAFT BONGO</b>									
WB500	7"	✓			TS-C-11	TTR-26	LUG-07		41
WB500	9"	✓			TS-C-12	TTR-27	LUG-07		41
<b>SPARE PARTS FOR STANDS</b>									
Memory Clamp, chrome, for middle stand tube for TMB + TMB-S					STAND-07				42
Memory Clamp, chrome, for lower stand tube for TMB + TMB-S					STAND-09				42
Memory Clamp, chrome, for upper stand tube for TMB					STAND-11				42
Fast Lock Set, chrome for TMB + TMB-S					STAND-14				42
Rubber Feet (set of 3 pcs.) for all Bongo Stands					STAND-16				42
L-Shaped Clamp for top part for TMB + TMB-S					STAND-18				42
Upper Stand Section, complete for TMB					STAND-34				42
<b>OTHER PARTS</b>									
Lug Oil					SPARE-09				
Tuning Key, 13mm + 14mm, L-shaped, chrome					KEY-02				

Madeleine Wegner and Kim Moore

Felix Bucka

Drum Teacher Ensemble of the Conservatory of Perqgnan

# Spare Parts

# Spare Parts

*Djembes*

Model No.	Size	Height	Material	Features	SPARE PARTS				Page
					Head	Rim	Lug	Bracket	
			Mahogany Wood Rubber Wood Premium Fiberglass American White Ash True Skin Goat Heads True Skin Calf Heads Floatune Tuning System Rope Tuning System SSR-Rim						
<b>HEADLINER® SERIES ROPE TUNED DJEMBES CONGO SERIES</b>									
HDJ1-M	10"	20"						HEAD-53	64
HDJ1-L	12"	24"						HEAD-54	64
HDJ1-XL	13"	25"						HEAD-55	64
<b>HEADLINER® SERIES ROPE TUNED DJEMBES TRIBAL SERIES</b>									
HDJ2-M	10"	20"						HEAD-53	65
HDJ2-L	12"	24"						HEAD-54	65
HDJ2-XL	13"	25"						HEAD-55	65
<b>ORIGINAL AFRICAN STYLE ROPE TUNED WOOD DJEMBE WATER RHYTHM SERIES</b>									
ADJ2-M+BAG	10"	20"						HEAD-53	66
ADJ2-L+BAG	12"	24"						HEAD-54	66
ADJ2-XL+BAG	13"	25"						HEAD-55	66
<b>ORIGINAL AFRICAN STYLE ROPE TUNED WOOD DJEMBE EARTH RHYTHM SERIES</b>									
ADJ3-M+BAG	10"	20"						HEAD-53	67
ADJ3-L+BAG	12"	24"						HEAD-54	67
ADJ3-XL+BAG	13"	25"						HEAD-55	67
<b>ORIGINAL AFRICAN STYLE ROPE TUNED WOOD DJEMBE MOON RHYTHM SERIES</b>									
ADJ4-M+BAG	10"	20"						HEAD-53	68
ADJ4-L+BAG	12"	24"						HEAD-54	68
ADJ4-XL+BAG	13"	25"						HEAD-55	68
<b>PROFESSIONAL AFRICAN DJEMBES</b>									
PROADJ1	12"	24"						HEAD-54	69
PROADJ2	12"	24"						HEAD-54	69
<b>AFRICAN BOUGARABOU</b>									
ABGB-L	12"	24"						HEAD-63	70
<b>ROPE TUNED WOOD DJEMBES</b>									
DJWR3	12"	24 1/4"						TS-CA-01	70
<b>HEADLINER® SERIES WOOD DJEMBES / DESIGNER SERIES DJEMBE</b>									
HDJ600	12"	23 1/2"						HHEAD12W HRIM12W HDLUGW HDBRACKET-02	71
<b>FLOATUNE SERIES 12 3/4" WOOD DJEMBES</b>									
DJW2	12 3/4"	25 1/4"						TS-G-02 SSR-30 LUG-04	72
<b>FLOATUNE SERIES 12" WOOD DJEMBES</b>									
DJW3	12"	24 1/4"						TS-G-01 SSR-29 LUG-04	72/73
<b>FLOATUNE SERIES FIBERGLASS DJEMBES</b>									
DJF3	12"	24 1/4"						TS-G-01 SSR-29 LUG-05	73
<b>SPARE PARTS FOR STANDS</b>									
Rubber Feet (set of 3 pcs.) for Steely-II Stand								STAND-35	74
Rubber Tops (set of 3 pcs.) for Steely-II Stand								STAND-21	74
Socket Screw (set of 2 pcs.) chrome								STAND-27	74
Fast Lock Set, chrome								STAND-14	74
Rubber Feet (set of 3 pcs.) for Djembe Stand								STAND-16	74
<b>OTHER PARTS</b>									
Lug Oil								SPARE-09	
Tuning Key, 13mm + 14mm, L-shaped, chrome								KEY-02	

Model No.	Size	Material	Features	SPARE PARTS				Page	
				Head	Rim	Lug	Bracket		
		Hardwood Aluminum Premium Fiberglass Rubber Wood ABS Steel	Counter sunk bolt heads Replaceable synthetic heads Replaceable goat heads Height adjustable legs Steel snare wires Floatune Tuning System						
<b>PANDEIROS</b>									
PA10	10"							HEAD-44 RIM-33 LUG-24 BRACKET-19	77
PA12	12"							HEAD-45 RIM-34 LUG-24 BRACKET-19	77
<b>FLOATUNE TAMBORIMS</b>									
TBR06	6"							HEAD-40 RIM-32 LUG-20	78
<b>FIBERGLASS QWEEKA</b>									
QW7	8"							HEAD-13 RIM-10 LUG-13	81
<b>ALUMINUM QWEEKAS</b>									
QW6	6"							HEAD-57 RIM-44 LUG-35	81
QW10	10"							HEAD-58 RIM-45 LUG-36	81
<b>ALUMINUM CAIXAS</b>									
CA12	12"							HEAD-51 RIM-42 (Top) LUG-33	82
CA14	14"							HEAD-52 RIM-43 (Top) LUG-34	82
<b>TRADITIONAL CAIXA</b>									
CA12T	12"							HEAD-51 RIM-42 (Top) LUG-41	82
<b>ALUMINUM REPINQUES</b>									
RE10	10"							HEAD-48 RIM-39 (Top) LUG-29	83
RE12	12"							HEAD-47 RIM-36 (Top) LUG-28	83
<b>WOOD REPINIQUE</b>									
RE12	12"							HEAD-47 RIM-36 LUG-32	83
<b>ALUMINUM SURDOS</b>									
SU16	16"							HEAD-59 RIM-46 (Top) LUG-37	84
SU18	18"							HEAD-49 RIM-40 (Top) LUG-30	84
SU20	20"							HEAD-46 RIM-35 (Top) LUG-27	84
SU22	22"							HEAD-50 RIM-41 (Top) LUG-31	84
<b>STAND ALONE ALUMINUM SURDOS</b>									
SU16-L	16"							HEAD-59 RIM-46 (Top) LUG-37	84
SU18-L	18"							HEAD-49 RIM-40 (Top) LUG-30	84
SU20-L	20"							HEAD-46 RIM-35 (Top) LUG-27	84
SU22-L	22"							HEAD-50 RIM-41 (Top) LUG-31	84
<b>WOOD SURDOS</b>									
SU16	16"							HEAD-59 RIM-46 (Top) LUG-37	85
SU18	18"							HEAD-49 RIM-40 (Top) LUG-30	85
SU20	20"							HEAD-46 RIM-35 (Top) LUG-27	85
SU22	22"							HEAD-50 RIM-41 (Top) LUG-31	85
<b>STAND ALONE WOOD SURDOS</b>									
SU16-L	16"							HEAD-59 RIM-46 (Top) LUG-37	85
SU18-L	18"							HEAD-49 RIM-40 (Top) LUG-30	85
SU20-L	20"							HEAD-46 RIM-35 (Top) LUG-27	85
SU22-L	22"							HEAD-50 RIM-41 (Top) LUG-31	85
<b>BAHIA ALUMINUM SURDOS</b>									
SUB18	18"							HEAD-49 RIM-40 (Top) LUG-38	86
SUB20	20"							HEAD-46 RIM-35 (Top) LUG-39	86
SUB22	22"							HEAD-50 RIM-41 (Top) LUG-40	86
<b>BAHIA WOOD SURDOS</b>									
SUB18	18"							HEAD-49 RIM-40 (Top) LUG-38	86
SUB20	20"							HEAD-46 RIM-35 (Top) LUG-39	86
SUB22	22"							HEAD-50 RIM-41 (Top) LUG-40	86
<b>OTHER PARTS</b>									
A Go Go Bell Holder								STBAGH	
Tuning Key for Pandeiro								KEY-08	
Tuning Key for Caixa								KEY-09	
Tuning Key for Surdo and Repinique								KEY-10	

*Spare Parts*

# Spare Parts

Model No.	Size	Material	Features	SPARE PARTS				Page
				Head	Rim	Lug	Bracket	
<b>Timbales</b>								
		German B8 cymbal bronze Solid brass Stainless steel Black powder coated steel Steel	Hammered shells Two worked in flanges Cuban style (bottom edge) Special brackets cast Floatune Tuning System					
<b>PROFESSIONAL SERIES</b>								
BT1415	14"			HEAD-22	RIM-19	LUG-16	BRACKET-10 chrome	89
BT1415	15"			HEAD-23	RIM-20	LUG-16	BRACKET-11 chrome, small	89
<b>ARTIST SERIES, Luis Conte</b>								
LC1	14"			HEAD-22	RIM-19	LUG-16	BRACKET-08 brass	90
LC1	15"			HEAD-23	RIM-20	LUG-16	BRACKET-09 brass, small BRACKET-10 chrome BRACKET-11 chrome, small	90 90 90
<b>ARTIST SERIES, Amadito Valdés</b>								
AV1BK	14"			HEAD-22	RIM-27	LUG-17		91
AV1BK	15"			HEAD-23	RIM-28	LUG-17		91
<b>FLOATUNE SERIES</b>								
TI1BK	13"			HEAD-24	RIM-21	LUG-17		91
TI1BK	14"			HEAD-22	RIM-22	LUG-17		91
<b>MARATHON® SERIES</b>								
MT1415	14"			HEAD-22	RIM-23	LUG-17	BRACKET-12	92
MT1415	15"			HEAD-23	RIM-24	LUG-17	BRACKET-12	92
<b>HEADLINER® SERIES</b>								
HT1314	13"			HEAD-24	RIM-37	LUG-26	BRACKET-18	93
HT1314	14"			HEAD-22	RIM-38	LUG-26	BRACKET-18	93
<b>DRUMMER TIMBALE</b>								
MDT13CH	13"			HEAD-43	RIM-31	LUG-21	BRACKET-13	93
<b>MINI TIMBALE</b>								
MIT810CH	8"			HEAD-41	RIM-29	LUG-21	BRACKET-13	93
MIT810CH	10"			HEAD-42	RIM-30	LUG-21	BRACKET-13	93

SPARE PARTS FOR STANDS	
Timbale Stand, chrome	TMT
Cowbell Holder, complete for MEINL Timbales	STAND-01
Cowbell Holder, complete for HT1314 Timbales	HDSTAND-01
Memory Clamp, chrome for middle stand tube	STAND-07
Memory Clamp, black for middle stand tube	STAND-08
Memory Clamp, chrome for lower stand tube	STAND-09
Memory Clamp, black for lower stand tube	STAND-10
Fast Lock Set, chrome	STAND-14
Fast Lock Set, black	STAND-15
Rubber Feet (set of 3 pcs.) for Timbales Stand	STAND-16

OTHER PARTS	
Lug Oil	SPARE-09
Tuning Key, 13mm + 14mm, L shaped, chrome	KEY-02

Model No.	Size	Material	Features	SPARE PARTS				Page
				Head	Rim	Lug	Bracket	
<b>Ritual Drums</b>								
<b>TALKING DRUM</b>								
TD7	7 1/2"	Aluminum Copper	Premium Fiberglass Synthetic Heads Hand selected buffalo heads Natural rawhide True Skin Buffalo Heads TTR-Rim Hand hammered shell Hand engraved shell	HEAD-35	RIM-25			123
<b>BATAS</b>								
BA1	5 1/4"			HEAD-07	RIM-04	LUG-12		124
BA1	8"			HEAD-08	RIM-05	LUG-12		124
BA2	5 3/4"			HEAD-09	RIM-06	LUG-12		124
BA2	8 3/4"			HEAD-10	RIM-07	LUG-12		124
BA3	6 3/4"			HEAD-11	RIM-08	LUG-12		124
BA3	12"			HEAD-12	RIM-09	LUG-12		124
<b>WOOD CONGUITAS</b>								
HCG89	8"			HEAD-05	TTR-05	LUG-11	HDBRACKET-02	124
HCG89	9"			HEAD-06	TTR-08	LUG-11	HDBRACKET-02	124
<b>TAMBORA</b>								
MTA1	11"			TS-B-09 (NT)	RIM-03	LUG-10	BRACKET-06	124
MTA1	11"			TS-B-10 (WH)		LUG-10	BRACKET-06	124

Model No.	Size	Material	Features	SPARE PARTS				Page
				Head	Rim	Lug	Bracket	
<b>Dancing Drums</b>								
<b>FIBERGLASS DANCING CONGA</b>								
HC301	8 1/2"	Aluminum Copper	Premium Fiberglass Synthetic Heads Hand selected buffalo heads Natural rawhide True Skin Buffalo Heads TTR-Rim Hand hammered shell Hand engraved shell	HHEAD8,5	HRIM8,5	HDCLUG	HDBRACKET-02	130
<b>FIBERGLASS DANCING DJEMBE</b>								
HDJ400	12"			HHEAD12	HRIM12	HDLUG	HDBRACKET-02	130
<b>FIBERGLASS MINI DANCING DJEMBES</b>								
HDJ200	8"			HHEADJ8	HRIMJ8	HD200LUG		130
<b>FIBERGLASS FAMILY DRUMS</b>								
HFDD1	8 3/4"			HHEADHFDD1	HRIMHFDD1	HFDDLUG	HFDDBRACKET	130
HFDD2	8"			HHEADHFDD2	HRIMHFDD2	HFDDLUG	HFDDBRACKET	130
HFDD3	7 1/2"			HHEADHFDD3	HRIMHFDD3	HFDDLUG	HFDDBRACKET	130

OTHER PARTS	
A Go Go Bell Holder	STBAGH
Tuning Key	KEY-08



Mao Cheng and Ramona Kestler

Stefanie Scherf

Elfriede Schmitt-Schultes

Hubert Schultes

# Spare Parts

*Doombeks/  
Darbukas*

Model No.	Size	Material	Features	SPARE PARTS					Page
				Head	Rim	Lug	Bracket		
<b>COPPER DOUMBK</b>									
HE-3012	8 1/2"	Aluminum	Hand selected buffalo heads	X				HE-HEAD-3000	132
<b>ALUMINUM DOUMBKS</b>									
HE-3030	8 1/2"	Copper	Synthetic Heads	X				HE-HEAD-3000	132
HE-3400	8 1/2"	Rubber Wood	Natural rawhide	X				HE-HEAD-3000	132
HE-3020	8 1/2"	Premium Fiberglass	True Skin Buffalo Heads	X				HE-HEAD-3000	133
HE-3000	8 1/2"		TTR-Rim	X				HE-HEAD-3000	133
<b>ALUMINUM DARBUKAS</b>									
HE-100	5 1/3"		Hand hammered shell	X				HE-HEAD-100	134
HE-101	5 7/8"		Hand engraved shell	X				HE-HEAD-101	134
HE-102	6 1/2"			X				HE-HEAD-102	134
HE-103	7 1/4"			X				HE-HEAD-103	134
HE-104	8"			X				HE-HEAD-104	134
HE-113	7 1/4"			X				HE-HEAD-103	135
HE-114	8"			X				HE-HEAD-104	135
<b>ALUMINUM JINGLE DARBUKAS</b>									
HE-314	8"			X				HE-HEAD-104	134
HE-315	8 1/4"			X				HE-HEAD-315	134
<b>COPPER DARBUKAS</b>									
HE-214	7 1/2"			X				HE-HEAD-214	135
HE-215	7 7/8"			X				HE-HEAD-215	135
HE-204	7 1/2"			X				HE-HEAD-204	135
HE-205	7 7/8"			X				HE-HEAD-205	135

*Nino<sup>®</sup>  
Percussion*

Model No.	Size	Height	Material	Features	SPARE PARTS					Page			
					Head	Rim	Lug	Bracket					
<b>CONGA SETS</b>													
NIN089	8"	22"	Rubber Wood	Hand selected buffalo heads	X				HEAD-NIN089-8	RIM-NIN089-8	LUG-NIN089	BRACKET-NI89	146
NIN089	9"	22"	Premium Fiberglass	Hand selected goat heads	X				HEAD-NIN089-9	RIM-NIN089-9	LUG-NIN089	BRACKET-NI89	146
NIN0910	9"	28"	ABS Plastic	Rounded rims	X				HEAD-NI910-9	RIM-NI910-9	LUG-NIN0910	BRACKET-NI89	147
NIN0910	10"	28"	Mahogany Wood	Floatune Tuning System	X				HEAD-NI910-10	RIM-NI910-10	LUG-NIN0910	BRACKET-NI89	147
<b>BONGOS</b>													
NIN03	6 1/2"			Hand selected buffalo heads	X				HEAD-NIN03-65	RIM-NI3-65-BK	LUG-NIN03		148
NIN03	7 1/2"			Hand selected goat heads	X				HEAD-NIN03-75	RIM-NI3-75-BK	LUG-NIN03		148
NIN03	6 1/2"			Rounded rims	X				HEAD-NIN03-65	RIM-NI3-65-BL	LUG-NIN03		148
NIN03	7 1/2"			Floatune Tuning System	X				HEAD-NIN03-75	RIM-NI3-75-G	LUG-NIN03		148
NIN017	6 1/2"			Rope Tuning System	X				HEAD-NIN03-65	RIM-NI3-65-BK	LUG-NIN03		148
NIN017	7 1/2"				X				HEAD-NIN03-75	RIM-NI3-75-BK	LUG-NIN03		148
<b>AFRICAN STYLE ROPE TUNED WOOD DJEMBES</b>													
NINO-ADJ2-XS	6 1/4"-8 1/4"	11 3/4"		Hand selected buffalo heads	X				HEAD-60				166
NINO-ADJ2-S	7"-8 1/2"	15 3/4"		Hand selected goat heads	X				HEAD-61				166
<b>AFRICAN STYLE ROPE TUNED WOOD DJEMBES</b>													
NINO-ADJ3-XS	6 1/4"-8 1/4"	11 3/4"		Hand selected buffalo heads	X				HEAD-60				166
NINO-ADJ3-S	7"-8 1/2"	15 3/4"		Hand selected goat heads	X				HEAD-61				166
<b>AFRICAN STYLE ROPE TUNED WOOD DJEMBES</b>													
NINO-ADJ4-XS	6 1/4"-8 1/4"	11 3/4"		Hand selected buffalo heads	X				HEAD-60				166
NINO-ADJ4-S	7"-8 1/2"	15 3/4"		Hand selected goat heads	X				HEAD-61				166
<b>WOOD DJEMBE</b>													
NIN023	10"	21"		Hand selected buffalo heads	X				HEAD-NIN023	RIM-NIN023	LUG-NIN023		167
<b>SPARE PARTS FOR STANDS</b>													
8" Basket Stand for NIN089					NISTAND-08					146			
9" Basket Stand for NIN089					NISTAND-09					146			
9" Basket Stand for NIN0910					NISTAND9					147			
10" Basket Stand for NIN0910					NISTAND10					147			
<b>OTHER PARTS</b>													
Lug Oil					SPARE-09								
Wood Beater					NIN09								
Triangle Beater					NIN0567								
Tuning Key, 13mm, chrome					KEY-04								

# Meinl Online

Shoot a short film playing your MEINL instrument and get the chance to win a PRIZE! Every month we'll start a new video contest for the MEINL percussion community. We'll focus on a different product category on the site each month. Every video related to the "highlighted category" will be part of the contest.

meinlpercussion.com

Everyone who joins the MEINL percussion community can rate the video clips. This is how we will select the best video. The winner will be contacted by an official MEINL percussion team member and you can be mentioned in the MEINL percussion blog.

meinlpercussion.com

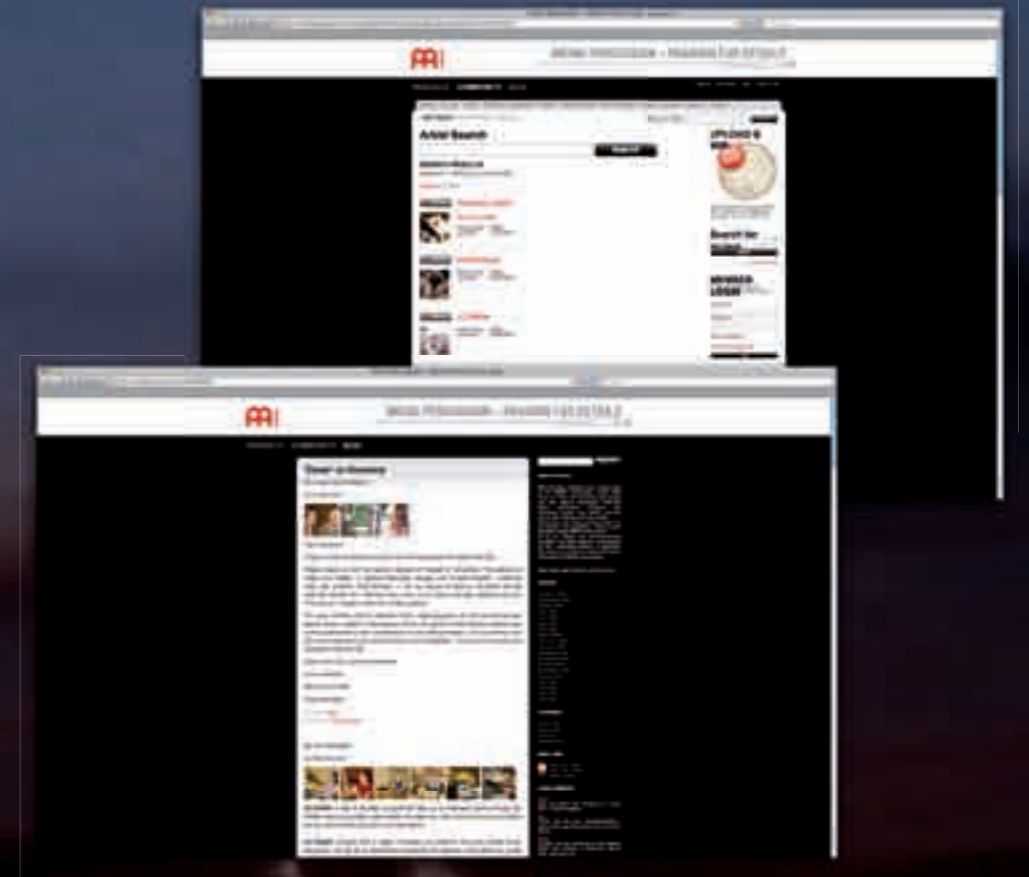

facebook.com

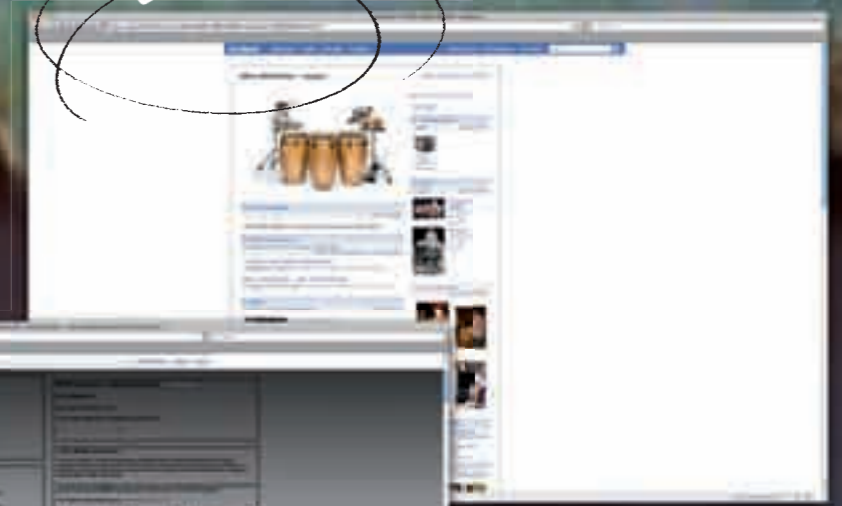

myspace.com











MEINL WOULD LIKE

TO THANK:

Everybody who participated in the  
FACES OF PERCUSSION  
contest!

IMPRESSUM

All features are subject to change without notice. Not responsible for typographic errors. No part of this book may be reprinted, reproduced, or included in any online service in any form in whole or in part, without the prior permission of MEINL.

© 2009 Roland Meinel Musikinstrumente GmbH & Co. KG

ADVERTISING  
CONCEPT & DESIGN BY:  
infowerk ag

CONTENT & DIRECTION BY:  
Udo Heubeck, Mario Schmitt

MEINL WOULD ALSO LIKE TO THANK:

Christian Habermeier  
and Sebastian Jäger,  
[www.studio-waldeck.de](http://www.studio-waldeck.de)

Chris Nöth,  
[www.chrisnoeth.de](http://www.chrisnoeth.de)

Markus Buberl,  
[www.triebwerk.net](http://www.triebwerk.net)

Patrick Cooperman and the  
Cooperman Company

Rüdiger Maul,  
[www.percussionprojects.com](http://www.percussionprojects.com)

MEINL GLOBAL HEADQUARTER  
Am Bahnhof 2  
91468 Gutenstetten  
Germany

MEINL USA L.C.  
3300 Ambrose Avenue  
Nashville, TN 37207  
USA

This catalogue has been printed on FSC certified paper

Printed in Germany M-CA501208



Passion for Details



[meinpercussion.com](http://meinpercussion.com)

