

2010  
The  
MEINL Book  
of Percussion!

Passion for Percussion



passion

community  
individual impression  
personality emotion  
freedom

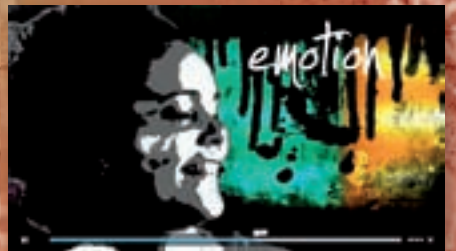
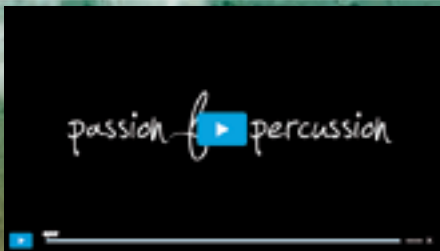

# Passion for Percussion

On the homepage of our web site you can see a video we made.

This video shows how people from all areas of life can come together thru music.

It is the passion for percussion that makes this possible.

There are no barriers, only room for expression. Expression of your emotion.

Only freedom. Freedom to show your personality. Through all this individual expression comes unity.

## Directory

PRODUCT GROUP	PAGE
Frame Drums	6
Samba	26
Cajons	36
Congas	52
Bongos	80
Dancing Percussion	91
Djembes	92
Timbales	106
Sticks	114
Gear	116
Candela Cymbals	117
Steelbells	118
Chimes	122
Shakers	126
Maracas	130
Guiros	131
Cabasa	132
Ritual Drums	134
Claves	141
Ibo Drums	142
Doumbeks	144
Darbukas	146
Hardware	148
Nino®	152
Merchandise	178

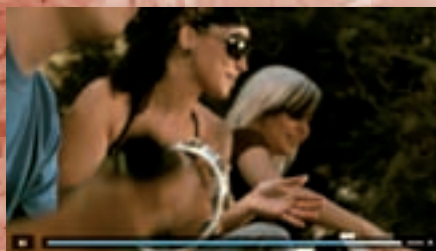

see the full video at [meinpercussion.com](http://meinpercussion.com)

It's our world -  
we care for it !!!

Actions speak louder than words! This is why we take our responsibility seriously and commit ourselves to several environmental projects.

Our specially developed vacuum distillation saves 90,000 liters of drinking water, the world's most threatened resource.

In order to minimize our electricity usage, all of our buildings are equipped with motion sensors and our centralized electricity controls prevents the waste of this resource.

With our solar-power-plant (Photovoltaic-System) we produce enough power to cover one-third of our annual demand or to supply 16 houses with electricity.

All of the electricity used in our facility is produced from renewable energies. Thus we reduced our carbon monoxide emission from 200 tons per year down to zero.

Reusable materials like paper, plastic or styrofoam are too precious to be wasted. We separate them for efficient recycling.

## WOOD FROM ENVIRONMENTALLY CONTROLLED WOOD PLANTATION

Thailand is a logical manufacturing base for percussion instruments due to the fact that the *Hevea Brasiliensis*, which was indigenous to Brazil and later transported by way England to Asia, has been commercially grown in Southeast Asia during the last century on plantation farms for the production of Latex.

The traditional plantation of Rubber Wood (*Hevea brasiliensis* Muell.-Arg.) meets all ecological requirements. Same counts for the plantation grown Mahogany Wood from Indonesia, which we use for our Original African Style Rope Tuned Wood Djembes. In a natural evolution, new trees are planted and the older ones, which have ceased to provide latex, are harvested. In this way, plenty of raw material is available and the valuable rain forest eco-system is preserved.

# MATERIAL & ECOLOGY

Wood is a raw material which is present in almost every part of our daily life. Trees are an important part of the complex eco-system while healthy forests are imperative for the Earth's atmosphere. Only plantation grown Wood is used for the making of MEINL and NINO® percussion instruments. This wood fulfils the CITES regulations ("Convention on International Trade in Endangered Species of Wild Fauna and Flora") and originates from environmentally controlled forests from industrial wood plantations.



Rubber Wood plantation farm in Thailand

# MEINL - The Ultimate Selection of Percussion

Always searching for new ideas and instruments

Authentic instruments from all cultures

MEINL offers many instruments in a more durable synthetic version

Traditional frame drums with modern features

Supreme craftsmanship

MEINL only uses eco-friendly plantation grown wood

We have the ultimate assortment of cajons  
(34 different models)

Huge selection of samba instruments

MEINL makes future  
ideas reality

Passion for details



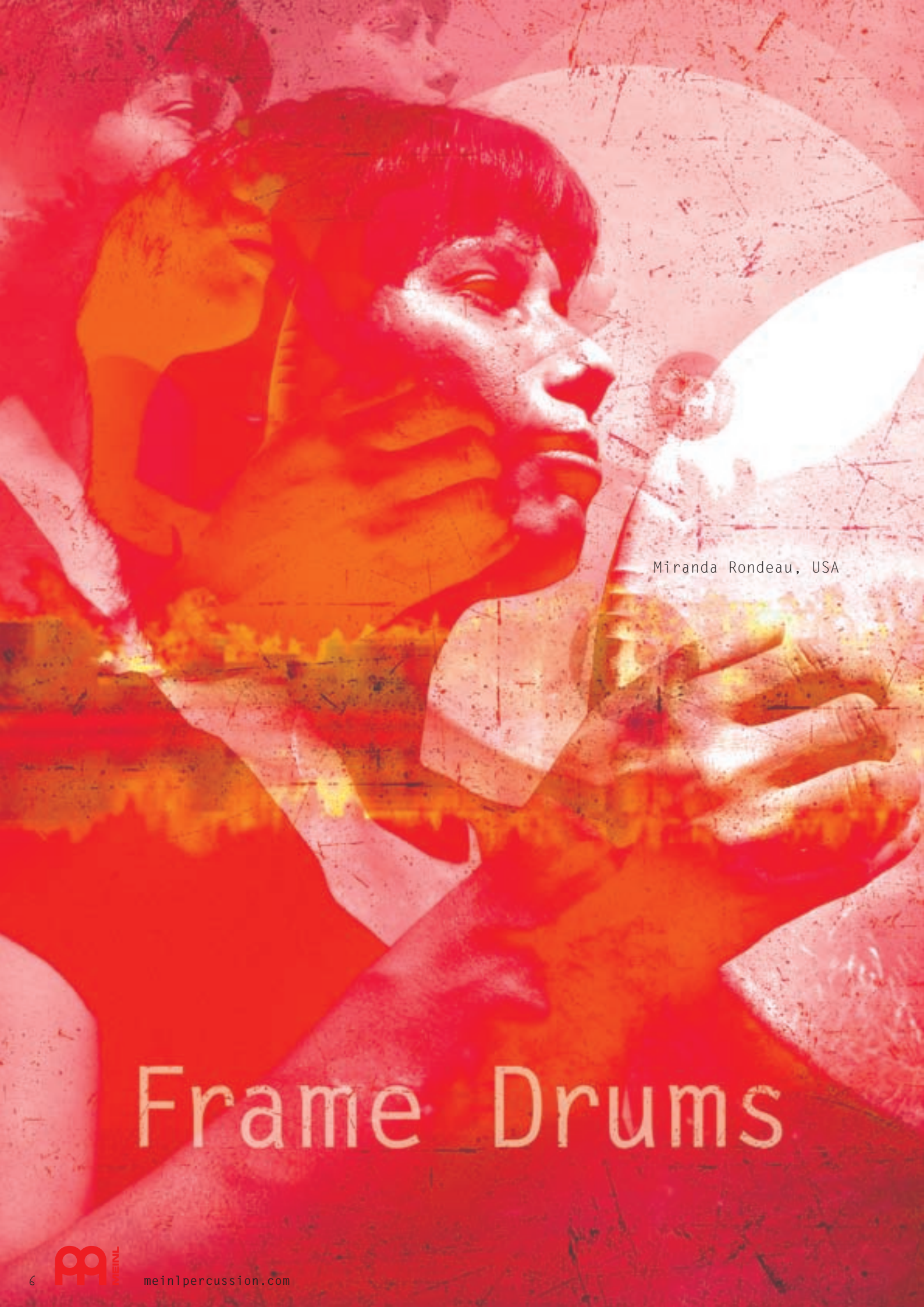

Miranda Rondeau, USA

# Frame Drums





Ellen Mayer, Germany

Javier Villar Morales,  
Spain

Rüdiger Maul,  
Germany

# Tars

The MEINL Tar is a tunable frame drum with a hand selected goatskin head. The tuning lugs are fully recessed within the frame for minimal interference. A scalloped thumb notch and light weight ensure comfortable playing.

- Sizes 16", 18", 20", 22"  
2 1/2" deep
- Materials Rubber Wood  
(*Hevea brasiliensis* Muell.-Arg.)  
Hand selected goat head
- Feature Internal lug tuning system
- Includes Allen wrench
- Colour AB = African Brown
- Finish Matte

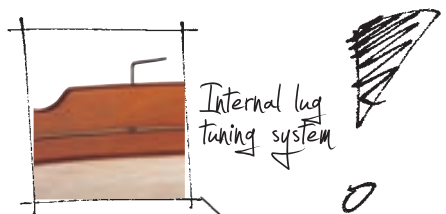

FD16T      FD18T      FD20T

Hand selected goat head for warm tones



Manu Tratz, Germany

# Tars with True Feel synthetic head

NEW!

Here at MEINL Percussion, we have developed our own True Feel synthetic heads especially for our frame drums, tambourines, and other hand drums. The lightly textured surface is both attractive and comfortable to play in any technique or style. True Feel heads are not reactive to moisture, so that assures a consistent tuning in all conditions. The tones are warm and bright, without excessive high frequency. Highly sensitive and refined play is possible with True Feel. Light and strong, True Feel heads are a breakthrough for MEINL Percussion, making a great addition to our frame drum family.

Sizes 16", 18", 20", 22"  
2 1/2" deep

Materials Rubber Wood  
(*Hevea brasiliensis* Muell.-Arg.)  
True Feel synthetic head

Feature Internal lug tuning system

Includes Allen wrench

Colour AB = African Brown

Finish Matte

For bags see page 15!



True Feel synthetic heads prevent the drum's pitch from being affected by humidity in outdoor venues.

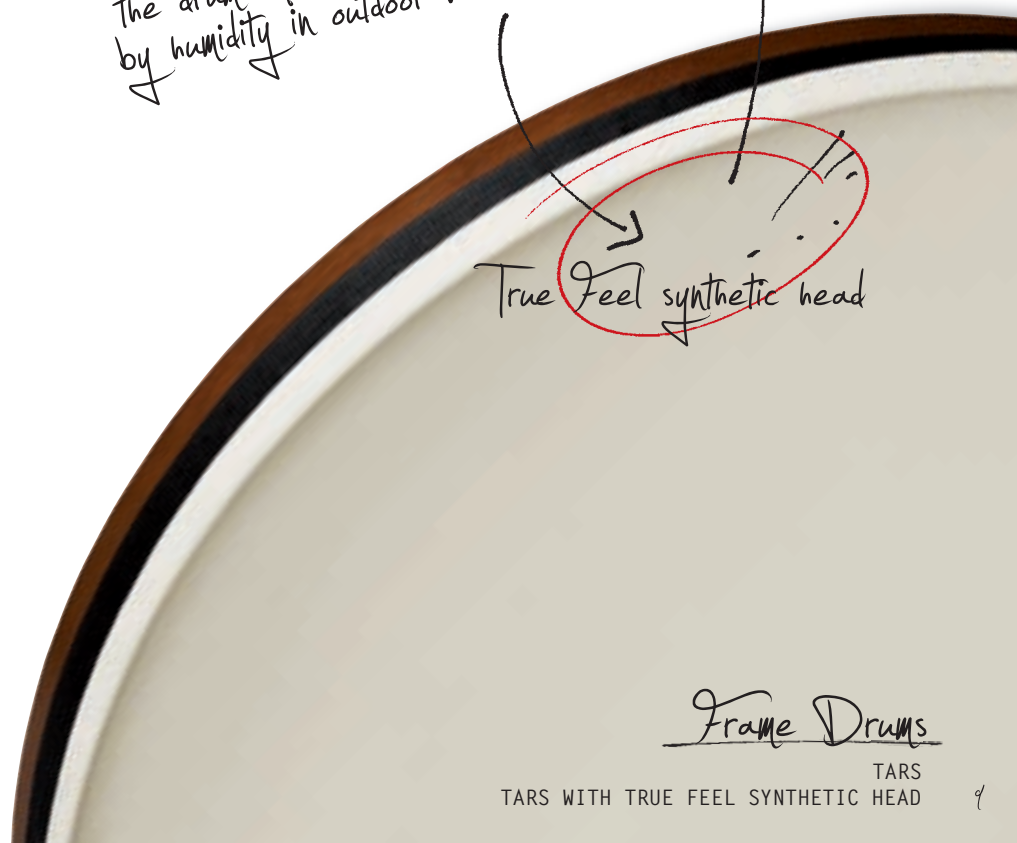

Frame Drums

# Deep Shell Tars

For bags see page 15

**NEW!**



## 1. DEEP SHELL TARS

The new MEINL Deep Shell Tars have an internal tuning system, and a traditional thumb hole grip for comfortable playing in the traditional style. The deep shells offer excellent sound development and come in a stunning burl finish.

<b>Sizes</b>	12", 14", 18" 4" deep
<b>Materials</b>	Rubber Wood ( <i>Hevea brasiliensis</i> Muell.-Arg.) Hand selected goat head
<b>Features</b>	Thumb hole grip Deep shell construction for full sound development Internal tuning system Stunning burl finish

<b>Includes</b>	Allen wrench
<b>Colour</b>	BB = Brown Burl
<b>Finish</b>	Matte

## 2. FRAME DRUM HOLDER

Sometimes a favorite frame drum just needs to be mounted on a percussion rack. That's why we designed a compact, light weight frame drum holder that is completely adjustable to fit any frame drum. Four rounded vertical "fingers" slide along individual tracks, and are secured by a knurled knob. This sets the spacing. The frame drum is secured when two spring-loaded screws are tightened so that the vertical fingers grip the frame from inside and out. Set-up and break-down go fast. Steel mounting clamp fits any standard rod.

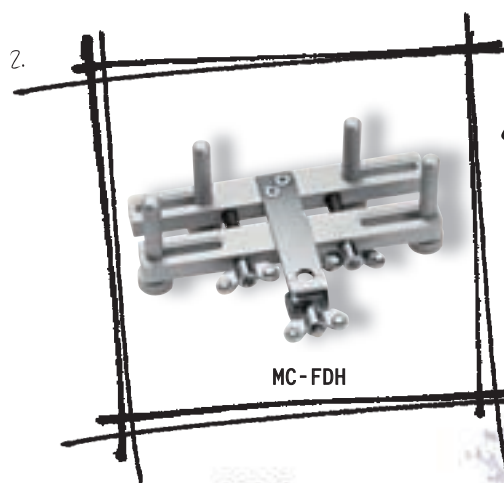

**NEW!**

<b>Materials</b>	Anodized aluminum Chrome-plated steel
<b>Features</b>	Fully adjustable

Fully adjustable for any frame drum size!

Omid Bahadori

Carina



# Deep Shell Tars with True Feel synthetic head

Deep Shell Tars have an internal tuning system, and a traditional thumb hole grip for comfortable playing in the traditional style. Our True Feel synthetic head has a great sound that is consistent under variable conditions. This makes True Feel an ideal choice for recording projects, or for outdoor play.

**NEW!**

Thumb hole for a good balance and comfortable playing

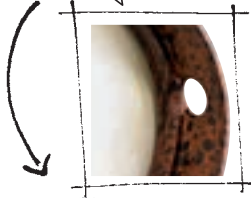

FD12T-D-TF



FD18T-D-TF



FD14T-D-TF

True Feel synthetic heads prevent the drum's pitch from being affected by humidity in outdoor venues

- Sizes 12", 14", 18"  
4" deep
- Materials Rubber Wood  
(*Hevea brasiliensis* Muell.-Arg.)  
True Feel synthetic head
- Features Thumb hole grip  
Deep shell construction for full sound development  
Internal tuning system  
Stunning burl finish
- Includes Allen wrench
- Colour BB = Brown Burl
- Finish Matte

Stunning burl finish

Miranda Rondeau, USA



Maximilian Röhrl



Frame Drums

# Bendirs

## 1. BENDIR

The MEINL Bendir features four thin strings stretched across the inside of the goatskin head, which create the classic Bendir "buzzing" sound. The Bendir is fully tunable and light in weight for long and comfortable playing.

1.

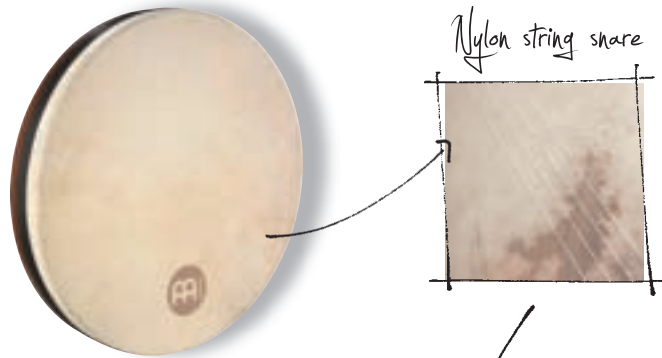

**FD16BE**

**Size** 16" and 2 1/2" deep  
**Materials** Rubber Wood  
 (Hevea brasiliensis Muell.-Arg.)  
 Hand selected goat head

**Feature** Buzzing effect  
 Internal lug tuning system  
**Includes** Allen wrench  
**Colour** AB = African Brown  
**Finish** Matte

## 2. TRADITIONAL BENDIRS

The MEINL Traditional Bendirs are made true to the classical North African form. Four adjustable nylon strings spanning the inside of the goatskin head create the characteristic buzzing sound. This fine frame drum is fully tunable, with rich bass tones and crisp taks. The body is deep for full sound development, yet light for comfort and extended play.

2.



**FD12BE**

**FD14BE**

**Sizes** 12" x 4"  
 14" x 4"  
**Materials** Rubber Wood  
 (Hevea brasiliensis Muell.-Arg.)  
 Hand selected goat head  
**Features** Internal tuning system  
 Buzzing effect  
 Thumb hole for a good balance and comfortable playing

Deep shell construction for full sound development  
 Thumb hole for a good balance and comfortable playing

## 3. BENDIRS WITH TRUE FEEL SYNTHETIC HEAD

The new MEINL Bendirs feature four thin stings stretched across the inside of the True Feel synthetic head, which create the classic Bendir "buzzing" sound. The Bendirs are fully tunable and light in weight for long and comfortable playing.

True Feel synthetic head

3.



**FD12BE-TF**

**FD14BE-TF**

**FD16BE-TF**

**Sizes** 12" x 4"  
 14" x 4"  
 16" x 2 1/2"  
**Materials** Rubber Wood  
 (Hevea brasiliensis Muell.-Arg.)  
 True Feel synthetic head  
**Features** Internal tuning system  
 Buzzing effect  
 Thumb hole for a good balance and comfortable playing  
**Includes** Allen wrench  
**Colour** AB = African Brown  
**Finish** Matte

NEW!

Jessica Krückerl and friends

# Daf NEW!

The MEINL Daf is a classical Persian frame drum with a rich tradition. It has ring snares nearly all the way around the inside of the drum, and is played with a lot of movement. MEINL percussion has a new style of Daf to suit the modern player! We placed the rings in three sections, at the top of the Daf, and on the left and right sides. This tempers the effect of the ring snares while saving some weight, and it enables the player to develop new techniques. The MEINL Daf comes with our great sounding and super-stable True Feel synthetic head.

- Size 20" x 2 1/2"
- Materials Rubber Wood  
(*Hevea brasiliensis* Muell.-Arg.)  
True Feel synthetic head
- Features Metal rings for special effects  
Extra light weight construction
- Includes Allen wrench
- Colour AB = African Brown
- Finish Matte

Extra light weight construction

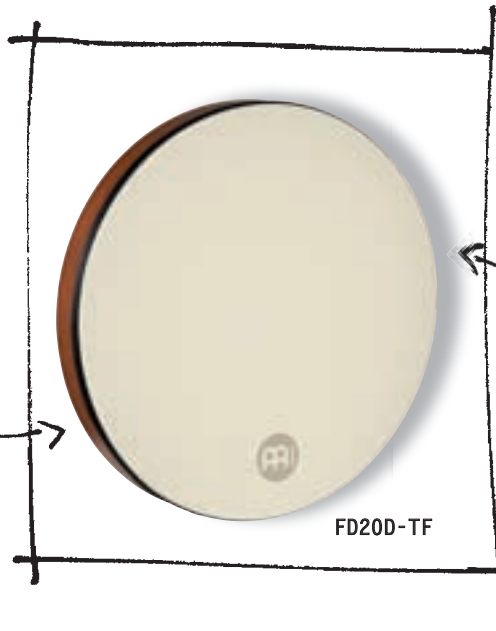

Metal rings for special effects

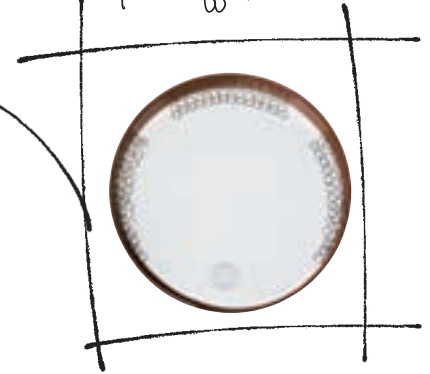

For bags see page 15



Holger Mertin Germany

Svetlana Zolotar

Monhus Schwarzmaier

Leutite

Christina Staudinger

Andreas Plucinsky

Frame Drums

BENDIRS  
DAF

# Frame Drums

## 1. BODHRAN

The MEINL Bodhran is made in the classic Celtic style. The drum is held by means of the wooden cross bars and is usually played with a double headed tipper. Internal tuning system ensures you find just the tuning you want.

1.

**FD18B0**

Size 18" x 4"  
 Materials Rubber Wood (Hevea brasiliensis Muell.-Arg.)  
 Hand selected goat head  
 Features Cross bar  
 Internal tuning system  
 Includes Allen wrench  
 Colour AB = African Brown  
 Finish Matte

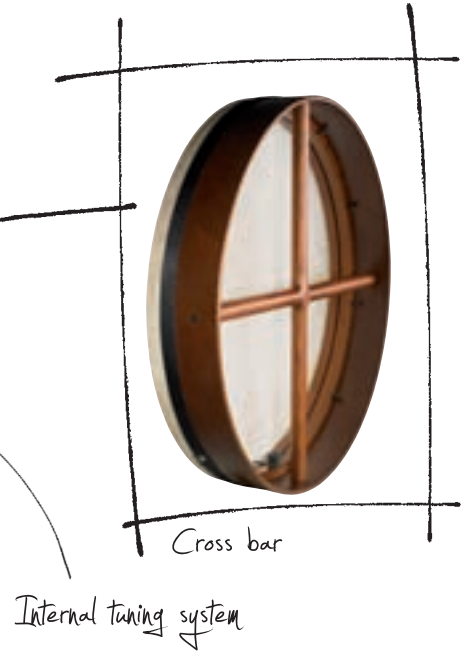

## 2. SEA DRUMS

MEINL Sea Drums create the soothing sounds of the surf, with a great new feature: we sealed the little steel balls between two drum heads, one synthetic and the other natural goatskin, or with our True Feel synthetic head for the 18" version. This means you can choose between two completely different timbres within the same drum. A sealable filling port allows you to control the amount of steel balls inside.

2.

Comes with our True Feel synthetic head

NEW!



Sealable filling port allows you to control the amount of steel balls inside

Sizes 16" x 2 3/4"  
 18" x 2 3/4"  
 20" x 2 3/4"  
 Materials Rubber Wood (Hevea brasiliensis Muell.-Arg.)  
 Hand selected goat head and synthetic head  
 FD18SD-TF: True Feel synthetic head and transparent head  
 Feature Sealable filling port allows you to control the amount of steel balls inside  
 Colour AB = African Brown  
 Finish Matte

## 3. HAND DRUMS

The MEINL Hand Drums are equipped with the finest hand selected frame goat heads. The scalloped grip guarantees a comfortable grip, which allows the fingers to apply pressure for a 'bending' note. Their light weight yet solid construction makes them perfect for unplugged situations and street percussion.

3.



Sizes 10", 12", 14", 16"  
 Materials Rubber Wood (Hevea brasiliensis Muell.-Arg.)  
 Hand selected goat heads  
 Colour AB = African Brown



# Bags

5.

Double-slide zipper →



MFDB-16 MFDB-18 MFDB-20 MFDB-22

Sizes 16", 18", 20", 22" and 2 1/2" deep  
 Material Heavy duty padded nylon  
 Features Double-slide zipper  
 Shoulder strap  
 Carrying grip

↓  
 Heavy duty padded nylon



Ramesh Shotham India/Germany

6.

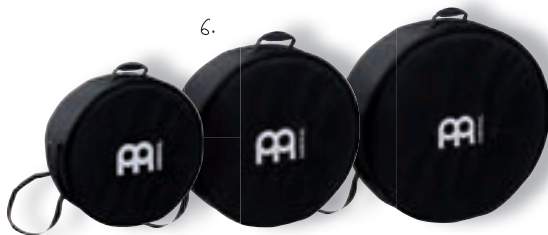

MFDB-12BE MFDB-14BE MFDB-18B0

Sizes 12" x 4"  
 14" x 4"  
 18" x 4"  
 Material Heavy duty padded nylon

Features Double-slide zipper  
 Shoulder strap  
 Carrying grip

## 5. PROFESSIONAL FRAME DRUM BAGS

The Professional Frame Drum Bags are made from heavy duty padded nylon with reinforced stitching. They protect your instruments and assures hassle free transportation.

## 6. PROFESSIONAL BAGS FOR DEEP SHELL FRAME DRUMS

The Professional Bags for Deep Shell Frame Drums are ideal for transporting your drum safely to your gig and back again. Made from heavy-duty padded nylon with reinforced stitching, they fully protect the instrument. Handy grips and shoulder strap make it easy to carry.

### Compatible with:

MFDB-22: FD22T, FD22T-TF  
 MFDB-20: FD20T, FD20T-TF, FD20SD, FD20D-TF  
 MFDB-18: FD18T, FD18-TF, FD18SD-TF  
 MFDB-16: FD16T, FD16T-TF, FD16BE, FD16SD, HD16AB

MFDB-18B0: FD18B0, FD18T-D, FD18T-D-TF  
 MFDB-14BE: FD14BE, FD14T-D, FD14T-D-TF, HD14AB  
 MFDB-12BE: FD12BE, FD12T-D, FD12T-D-TF



Ellen Mayer, Germany

Frame Drums

# Pandeiros

## 1. SHELL-TUNED PANDEIROS

The MEINL Shell-Tuned Pandeiros are great sounding pandeiros with internal tuning lugs. This frees the outside surface of the shell from protruding hardware, and saves weight. Hand selected goatskin heads have an authentic sound, and our super dry, hand-hammered brass jingles create a dazzling look and sound.

## 2. WOOD PANDEIROS

The Pandeiro is played with one hand while the other alters the pitch of the drum. Solid jingles produce a brilliant, dry and cutting sound.

## 3. VENTED JINGLE PANDEIROS

Our new Vented Jingle Pandeiro features our new True Feel synthetic head and comes with perforated brass jingles for a new look and a new sound. This and our internal tuning system makes this frame drum especially light and comfortable.

## 4. ABS PANDEIRO (US patent)

The MEINL ABS Pandeiro is made for extensive and energetic playing. Solid jingles produce a brilliant, dry and cutting sound.

## 5. PROFESSIONAL PANDEIRO BAGS

The MEINL Professional Pandeiro Bags are made from heavy duty padded nylon with reinforced stitching and are equipped with a double-slide zipper and a shoulder strap. They protect your instruments and provide hassle free transportation.

Perforated hand-hammered brass jingles for extra dry sound



PA10AB-M

1.



PA12AB-M



Internal lug tuning system

Sizes 10"  
12"

Materials Rubber Wood  
(*Hevea brasiliensis* Muell.-Arg.)  
Hand selected goat head

Features Internal lug tuning system  
Hand-hammered brass jingles  
Light weight

Includes Allen wrench

Colour AB-M = African Brown

Finish Matte

Hand-hammered brass jingles

2. Hand selected goat head

2.

PA10CN-M



PA12CN-M



Solid jingles

Sizes 10"  
12"

Materials Rubber Wood  
(*Hevea brasiliensis* Muell.-Arg.)  
Hand selected goat head

Features Countersunk bolt lugs  
Chrome plated hardware  
Replaceable hand selected goat heads

Includes Tuning key

Colour CN-M = Chest Nut

Finish Matte

# NEW!

PAV10AB-M-TF

3.



True Feel synthetic heads prevent the drum's pitch from being affected by humidity in outdoor venues

PAV12AB-M-TF



Sizes 10"  
12"

Materials Rubber Wood  
(*Hevea brasiliensis* Muell.-Arg.)  
True Feel synthetic head

Features Perforated hand-hammered brass jingles for extra dry sound  
Internal lug tuning system  
Light weight

Includes Allen wrench

Colour AB-M = African Brown

Finish Matte



*Gilson Silveira  
Italy*



**PA10ABS-BK**

*Logo applied from underneath the head to prevent from wearing off (US patent)*

- Size 10"
- Material ABS plastic
- Features Countersunk bolt lugs  
Chrome plated hardware  
Replaceable synthetic head  
Logo applied from underneath the head (US patent)
- Includes Tuning key
- Colour BK = Black

5.



**MPAB-10**

**MPAB-12**

- Sizes 10"  
12"
- Material Heavy duty padded nylon
- Features Double-slide zipper  
Shoulder strap  
External pocket

# The Ultimate Tambourine Selection

MEINL Wood Tambourines are made from a sturdy frame with jingles available in different materials, resulting in various sound possibilities. Their ergonomically shaped handle and light weight enable energetic playing.

## 1. SUPER-DRY STUDIO TAMBOURINES

The MEINL Super-Dry Studio Tambourines feature hand-hammered brass jingles on a wooden frame. They are available with one or two rows of jingles for your desired sound. We make them light and comfortable, for prolonged and precise playing.



STA1B-BK

STA2B-BK

Size 10"  
 Materials Hand-hammered brass  
 Wooden frame  
 Features Hand-hammered triangularly jingles for extra dry sound  
 1 row and 2 row version  
 Colour BK = Black



STA1B-BK

STA2B-BK

Size 10"  
 Materials Hand-hammered brass  
 Wooden frame  
 Features Hand-hammered triangular jingles for extra dry sound  
 1 row and 2 row version  
 Colour BK = Black

## 2. HEADED SUPER-DRY STUDIO TAMBOURINES

The MEINL Headed Super-Dry Studio Tambourines feature hand-hammered brass jingles on a wooden frame with a hand-selected goatskin head. Available with one or two rows of jingles, they are light, comfortable and have a great sound.

## 3. SUPER-DRY STUDIO TAMBOURINES, STAINLESS STEEL JINGLES

Our new Super-Dry Tambourines have hand-hammered stainless steel jingles with our popular triangular form. The sound is high, bright, and uplifting. They come in a 1 or 2 row version.

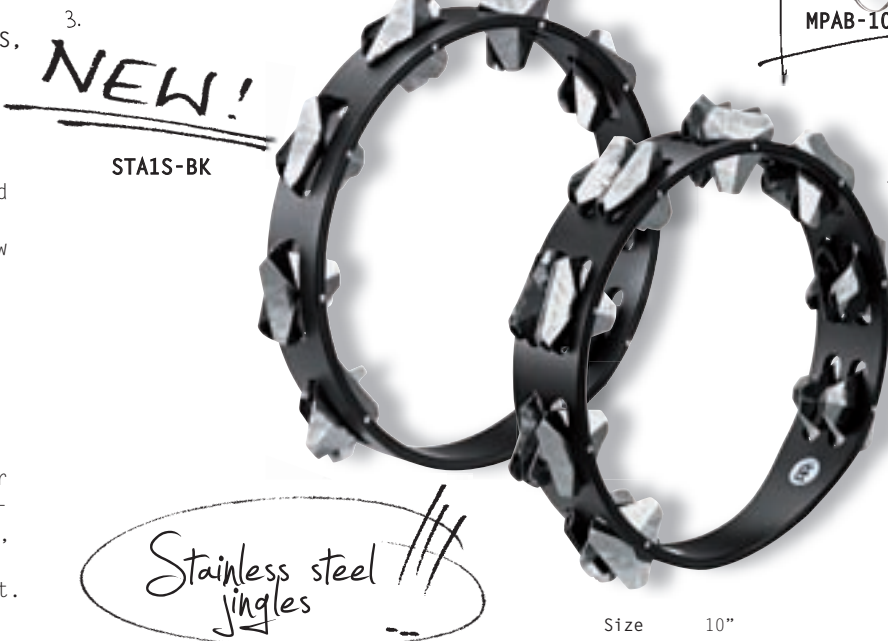

STA1S-BK

STA2S-BK

Size 10"  
 Materials Stainless steel  
 Wooden frame  
 Features Hand-hammered triangular jingles for an extra sweet sound with short sustain  
 1 row and 2 row versions  
 Colour BK = Black

## 4. HEADED SUPER-DRY STUDIO TAMBOURINES, STAINLESS STEEL JINGLES

The new MEINL Headed Super-Dry Tambourines with stainless steel jingles add another fresh sound to the wooden tambourine family. Hand-hammered, triangular jingles ensure a sweet and buttery sound effect.

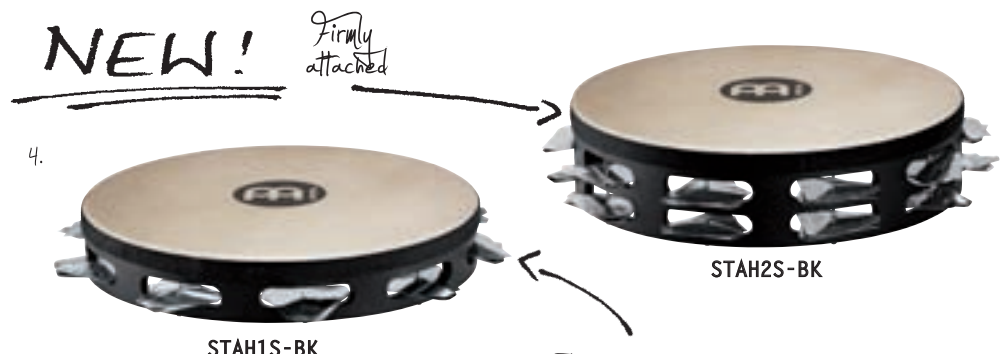

STA1S-BK

STA2S-BK

Size 10"  
 Materials Stainless Steel Jingles  
 Hand selected goat heads  
 Wooden Frame  
 Features Hand-hammered triangular jingles for an extra sweet sound with short sustain  
 1 row and 2 row versions  
 Colour BK = Black



MPAB-10

NEW!

5. COMPACT TAMBOURINES

Good sounds comes in small packages!  
 MEINL Percussion introduces a complete  
 line of Compact Tambourines. Light,  
 fast, and full of sound, they are  
 available in five different versions.

5.



CTA2S-BK

The 8" diameter makes them very compact



CTA2M-BK

The hand-hammered stainless steel jingles bring a new flavour to your rhythm



CTA2B-BK

- Size 8"
- Materials
  - Wooden frame
  - Brass jingles
  - Steel jingles
  - Hand-hammered Super-dry brass jingles
  - Hand-hammered Super-dry stainless steel jingles
- Features
  - Compact size
  - Many jingle variations
- Colour
  - BK = Black



CSTA2S-BK



CSTA2B-BK

See the difference!!

Regular tambourine size (10"), 16 pairs of jingles!

New compact tambourine in handy size (8"), 12 pairs of jingles!



Frame Drums

WOOD TAMBOURINES

# Wood Tambourines

MEINL's Wood Tambourines are made from a sturdy frame with jingles available in different materials, resulting in various sound possibilities. Their ergonomically shaped handle and light weight enable energetic playing.

## 1. TOURING TAMBOURINES

We created a new Tambourine that can go anywhere! Our Touring Tambourines feature our new True Feel synthetic heads and have black plated steel jingles which are high in pitch, bright, and have a good sustain.

## 2. RECORDING-COMBO WOOD TAMBOURINES

The MEINL Recording-Combo Wood Tambourines create a whole new sound colour. It is both dry and bright. It offers a sophisticated and highly adaptable sound, with both projection and sustain.

## 3. HEADED RECORDING-COMBO WOOD TAMBOURINES

The MEINL Headed Recording-Combo Wood Tambourines feature a hand selected goatskin head for full and warm tones, whether played with stick or hand.

1.

**NEW!**

The True Feel synthetic head maintain its tuning despite fluctuations in humidity



TAH1BK-R-TF

Size 10"  
 Materials Black plated steel jingles  
 Wooden frame  
 Features 1 Row and 2 row version  
 True Feel synthetic head  
 Colour R = Red



TAH2BK-R-TF



Black plated steel jingles!!

2.

TA1M-SNT



TA2M-SNT

Size 10"  
 Materials Nickelsilver plated steel meets solid brass  
 Wooden frame  
 Features Dual-alloy jingles  
 1 row and 2 row version  
 Colour SNT = Super Natural



See page 17

MPAB-10

TAH2M-SNT

Mixed jingles

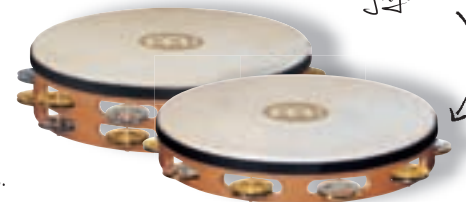

TAH1M-SNT

Size 10"  
 Materials Nickelsilver plated steel meets solid brass  
 Hand selected goat heads  
 Wooden frame  
 Feature Dual-alloy jingles  
 1 row and 2 row version  
 Colour SNT = Super Natural

## Arnold Riedhammer, Germany

Damaris Streckfuß



Benedicte Ross



4.

TA1AB



TA2AB

Size 10"  
Materials Nickelsilver plated steel  
Wooden frame  
Feature 1 row and 2 row version  
Colour AB = African Brown

6.

TA1A-AB

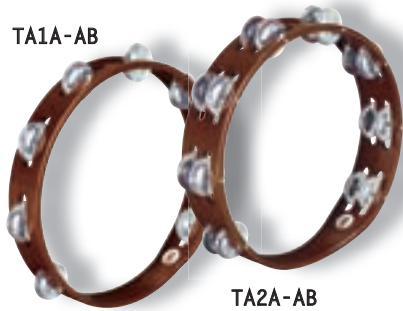

TA2A-AB

Size 10"  
Materials Aluminum  
Wooden frame  
Feature 1 row and 2 row version  
Colour AB = African Brown

8.

TA1B-AB



TA2B-AB

Size 10"  
Materials Solid brass  
Wooden frame  
Feature 1 row and 2 row version  
Colour AB = African Brown

5.



TA1AB

TA2AB

Size 10"  
Materials Nickelsilver plated steel  
Hand selected goat heads  
Wooden frame  
Feature 1 row and 2 row version  
Colour AB = African Brown

Hand selected  
goat head



7.

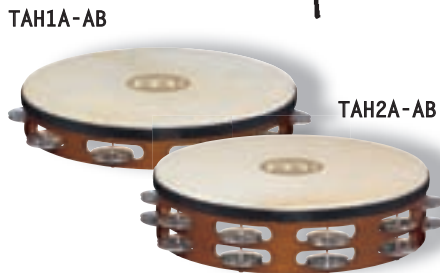

TA1A-AB

TA2A-AB

Super light  
weight due to  
the aluminum  
jingles

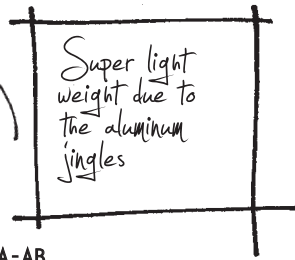

9.

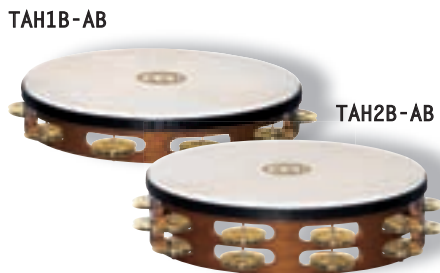

TA1B-AB

TA2B-AB

Size 10"  
Materials Solid brass  
Hand selected goat heads  
Wooden frame  
Feature 1 row and 2 row version  
Colour AB = African Brown

Solid brass jingles  
deliver a warm and  
cutting sound

#### 4. WOOD TAMBOURINES, STEEL JINGLES

Featuring 1 or 2 row versions, the MEINL Wood Tambourines with nickelsilver plated steel jingles produce a bright sound that projects well.

#### 5. HEADED WOOD TAMBOURINES, STEEL JINGLES

With steel jingles and the finest hand selected goat heads firmly attached, this instrument delivers a subtle and gentle tone when played by hand and a voluminous and rich sound.

#### 6. WOOD TAMBOURINES, ALUMINUM JINGLES

Featuring 1 or 2 row versions, the MEINL Wood Tambourines with aluminum jingles deliver a very soft and harmonic sound.

#### 7. HEADED WOOD TAMBOURINES, ALUMINUM JINGLES

With aluminum jingles and fine hand selected goat heads firmly attached to the shell, these tambourines have an extra-fine, bright, and sweet sound when played by hand or stick.

#### 8. WOOD TAMBOURINES, BRASS JINGLES

Featuring 1 or 2 row versions, solid brass jingles deliver a distinctively warm, and cutting sound.

#### 9. HEADED WOOD TAMBOURINES, BRASS JINGLES

These tambourines deliver a distinctively warm and cutting sound when played by hand or stick. Features 1 or 2 row versions.

Agnes Verger



# ABS Tambourines

MEINL Hand and Set-up Tambourines (design protected by a utility model) have a distinct design advantage due to the construction of the ABS frame. Unlike other tambourines, MEINL's utilizes several different parts in the frame which are assembled into a type of "sandwich." This results in unsurpassed durability.

## 1. TAMBOURINES, STEEL JINGLES

These ergonomically shaped tambourines are available as hand held or mountable versions. The durable ABS frame allows hard hitting and energetic hand playing. Nickel-silver plated steel jingles produce a bright sound that projects well.

### 2. ABS SUPER-DRY STUDIO TAMBOURINES

We enlarged our line of ergonomic ABS Tambourines with our popular hand-hammered brass super-dry jingles. This gives you a great new sound in the familiar form of our hand held or mountable ABS Tambourines.

### 3. TAMBOURINES, ALUMINUM JINGLES

The hand held versions are extremely light weight for extensive and energetic playing. The mountable version is built to resist hard hitting.

1.

TMT1BK

TMT1R

TMT2BK

TMT2R



**Materials** Nickelsilver plated steel  
ABS plastic

**Features** Padded soft grip for more playing comfort  
Ergonomic design  
Available as hand held or mountable versions  
Guiro style playing surface  
"Sandwich" construction

**Colours** BK = Black  
R = Red



*Steel jingles produce a bright sound that projects well*

*Great crashing sound for drumset players*

2.



STMT1B-BK

STMT2B-BK

**NEW!**

**Materials** Hand-hammered brass jingles  
ABS plastic body

**Features** Super-dry hand-hammered brass jingles  
Padded soft grip for more playing comfort  
Ergonomic design  
Available as hand held or mountable versions  
Guiro style playing surface  
"Sandwich" construction

**Colour** BK = Black

*Murdoch MacDonald, Scotland*



*Lele 'Shaddy' Sgarbi, Italy*



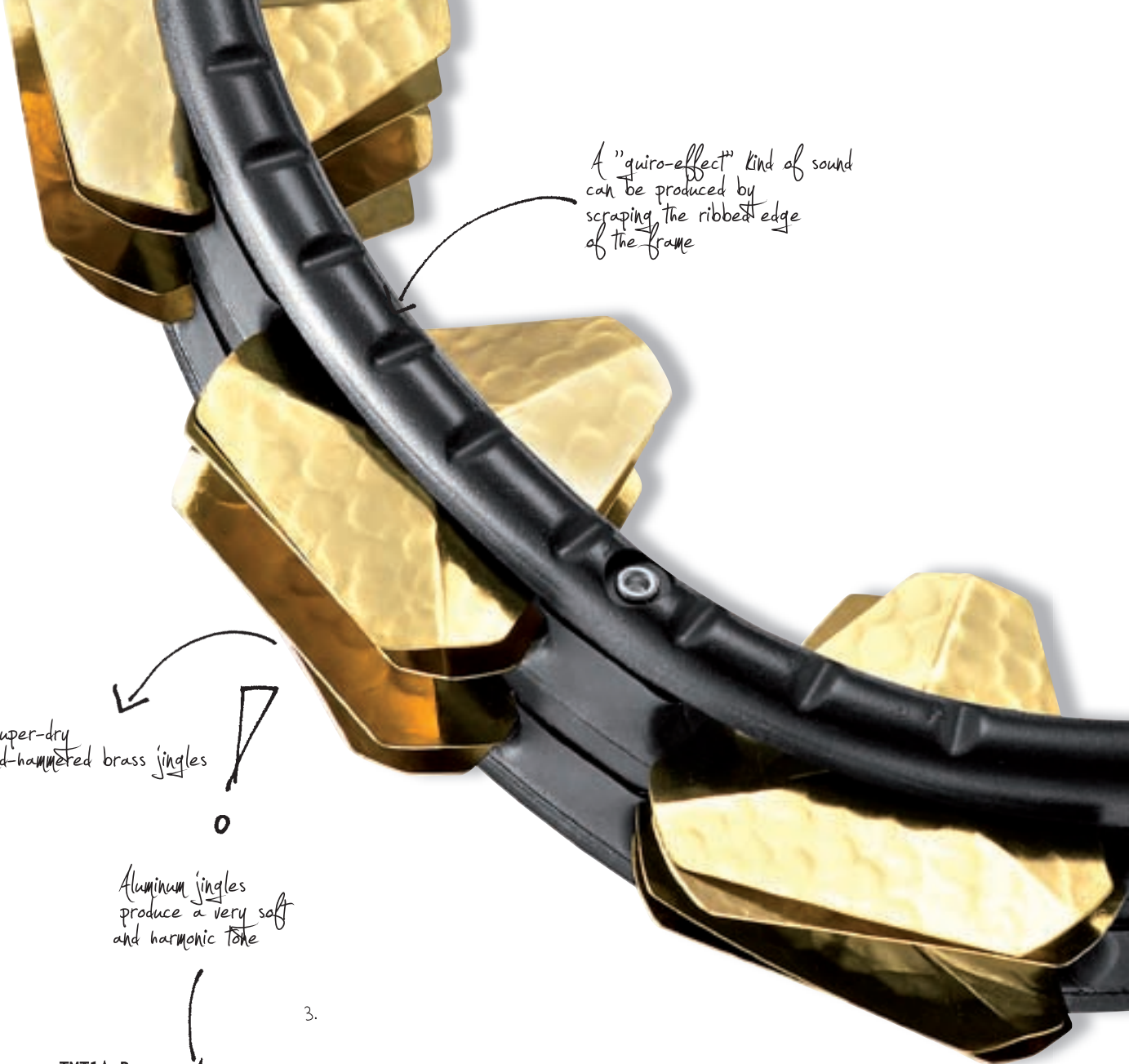

A "guiro-effect" kind of sound can be produced by scraping the ribbed edge of the frame

Super-dry hand-hammered brass jingles

Aluminum jingles produce a very soft and harmonic tone

TMT1A-WH

TMT1A-B

TMT2A-B



Easily mountable

- Materials Aluminum  
ABS plastic
- Features Padded soft grip for more playing comfort  
Ergonomic design  
Available as hand held or mountable versions  
Guiro style playing surface  
"Sandwich" construction
- Colours B = Blue  
WH = White (hand held only)

Padded ergonomic soft grip for more playing comfort



Sixto Maldonado

Adriane

Claudia "killer" Lippmann

# ABS Tambourines

## 1. RECORDING-COMBO ABS TAMBOURINES

The MEINL Recording-Combo ABS Tambourines feature our popular mixed jingles, where nickel-silver plated steel meets solid brass, for a unique and pleasing sound. Our special ABS "sandwich" construction makes them nearly indestructible.

## 2. TAMBOURINES, BRASS JINGLES

The durable ABS frame allows hard hitting and energetic hand playing. It delivers a very warm, yet cutting sound.

## 3. TAMBOURINE HOLDER

The tambourine holder converts a MEINL Hand Held Tambourine into a set-up tambourine. It holds it in place and is made to resist even the hardest hits.

1. Mixed jingles



TMT1M-WH

TMT2M-WH

**Materials** Nickelsilver plated steel and solid brass  
ABS plastic

**Features** Two different alloys of jingles  
Padded soft grip for more playing comfort  
Ergonomic design  
Available as hand held or mountable versions  
Güiro style playing surface  
"Sandwich" construction

**Colour** WH = White

Solid brass jingles produce a warm, yet cutting sound

2.

TMT1B-BK

TMT2B-BK



**Materials** Solid brass  
ABS plastic

**Features** Padded soft grip for more playing comfort  
Ergonomic design  
Available as hand held or mountable versions  
Güiro style playing surface  
"Sandwich" construction

**Colour** BK = Black

Rubber pads against scratching

3.

Padded surface against rattling

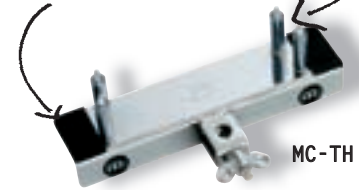

MC-TH

**Material** Chrome plated steel

**Features** Rubber pads against scratching  
Padded surface against rattling



Pau Martinez, Spain



Rocco Horn



Elke Aurnhammer

Jenny Flamann





4.

NEW!



Size 5"  
Materials Steel  
Brass  
Feature Rubber padded surface

4. HIHAT TAMBOURINES

A sturdy rubberized striking ring ensures a clean response and a long life. An easy-access wing nut allows quick set-up, adjustment, or removal, completely independent from your cymbals.

5. JINGLE STICKS

The MEINL Jingle Sticks create many interesting sound possibilities.

6. HEADLINER® SERIES JINGLE STICKS

The MEINL Headliner® Series Jingle Sticks are an affordable alternative to a tambourine. Nice sound effects are also achieved when used as a stick on a drum.

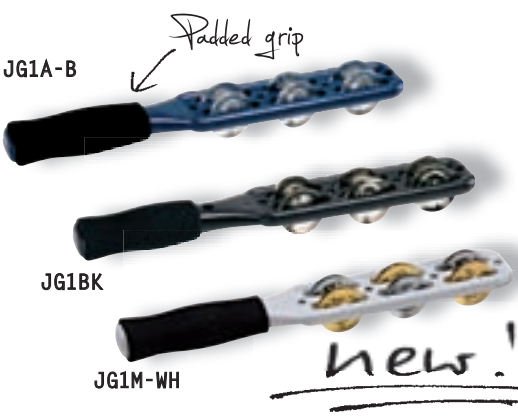

5.

Jingles JG1 = Nickelsilver plated steel  
JG1A = Aluminum  
JG1B = Solid brass  
JG1M = Nickelsilver plated steel and solid brass  
Features Padded grip  
Guiro style playing surface

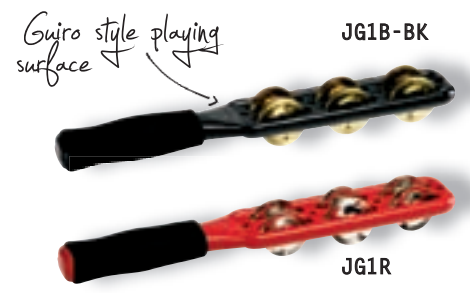

6.

Materials Nickelsilver plated steel  
ABS plastic  
Colours BK = Black  
R = Red

Katharina Wernecke  
and Florian Bauer

Gert Schultheiß

Andreas Weigand

Pia Weiße

Angelika Kramer



Tambourines, Jingle Sticks

ABS TAMBOURINES  
HIHAT TAMBOURINES, JINGLE STICKS, HEADLINER® SERIES JINGLE STICKS





# Samba

# Samba

Light weight ABS guarantees great stability and comfortable handling

## 1. FLOATUNE TAMBORIMS (US patent)

Tamborims are played with a plastic stick while one hand changes the pitch of the drum. It has a bright, loud, and cutting sound. MEINL offers a variety of tamborims all made from several high quality materials for several sound options.



Logo applied from underneath the head to prevent from wearing off (US patent)

Floatune Tuning System

## 2. PROFESSIONAL TAMBORIM BAG

The MEINL Tamborim Bag is made from heavy duty padded nylon with reinforced stitching. It is equipped with a double-slide zipper and a shoulder strap.

## 3. SAMBA WHISTLE

The MEINL Samba Whistle has three tones in a super-bright timbre. This is the classic Samba sound and spirit. Solid aluminum construction ensures years of use.

- Size 6"
- Materials ABS  
Aluminum  
Brass plated steel  
Chrome plated steel  
Rubber Wood (*Hevea brasiliensis* Muell.-Arg.)
- Features Floatune Tuning System  
Logo applied from underneath the head (US patent)  
Countersunk bolt lugs  
Replaceable synthetic heads
- Includes German "Pfennig" as tuning key



## 2. MTAB-06



Perfect fit

- Size 6"
- Material Heavy duty padded nylon
- Features Double-slide zipper  
Shoulder strap  
External pocket

## 3. SW1

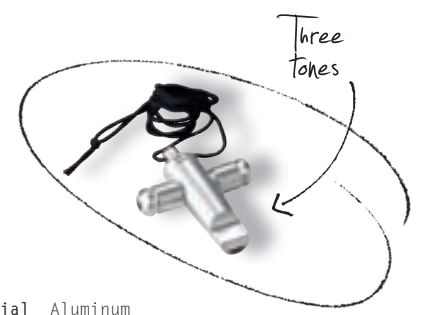

Three tones

- Material Aluminum
- Includes Neck lanyard



Gerhard Reiter, Austria

4.



**STBAG1**  
**STBAG2**

Sizes Small  
Large  
 Material Special steel alloy  
 Includes Mounting clamp for small model  
 Finish Hand brushed steel

5.



**STBAG4-CH**  
**STBAG2-CH**

Sizes Small  
Large  
 Material Special steel alloy  
 Feature Flexible connection  
 Finish High polished chrome

6.

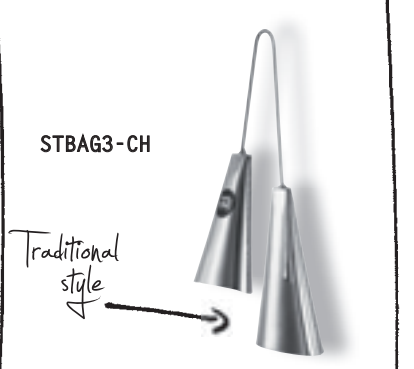

**STBAG3-CH**

Size Medium  
 Material Special steel alloy  
 Features Traditional shape  
Flexible connection  
 Finish High polished chrome

7.



RC1BK

20 pairs of solid jingles

Material Rubber Wood  
 (Hevea brasiliensis Muell.-Arg.)  
 Colour BK = Black  
 Feature 20 pairs of solid jingles

4. A-GO-GO STEEL FINISH MODELS

The MEINL A-Go-Go Bells are tonally matched especially for the requirements of South American rhythms.

5. A-GO-GO CHROME FINISH MODELS

These highly polished A-Go-Go Bells offer a bright sound and are equipped with a flexible connection. Ideal for Samba style music.

6. TRADITIONAL STYLE A-GO-GO BELL

The MEINL traditional style A-Go-Go Bell in our medium size is the perfect A-Go-Go Bell when the large is too much and the small one isn't enough.

7. ROCAR

The MEINL Rocar is equipped with 20 pairs of solid jingles mounted onto a wooden bar.

8. ALUMINUM SAMBA SHAKERS

The MEINL Samba Shakers are the ideal instruments for street Samba. Their shells are made from thin aluminum, which, when combined with solid steel shot, produce a warm, penetrating, and cutting shaker sound.

8

SINGLE SHAKERS

SSH1-S



SSH1-M



SSH1-L

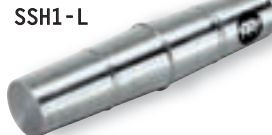

DOUBLE SHAKERS

SSH2-S



SSH2-M



SSH2-L



TRIPLE SHAKERS

SSH3-S



SSH3-M

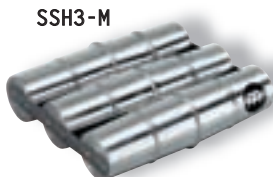

SSH3-L



Sizes Small, Medium, Large  
 Material Aluminum

Light weight aluminum



# Cuicas

## 1. FIBERGLASS CUICA

While one hand rubs the internal bamboo shaft with a moist cloth, the other hand controls the pressure of the head, thereby changing the pitch.

## 2. ALUMINUM CUICAS

MEINL offers two cuicas made from lightweight aluminum. Their light weight and solid construction makes them perfect for street Samba.

## 3. PROFESSIONAL CUICA BAGS

Professional Cuica Bags are a great way to protect your cuica in transport. Made from heavy duty padded nylon with reinforced stitching, the bags offer extra protection with reinforced side walls. Padded shoulder strap and carrying grip for hassle-free transport.

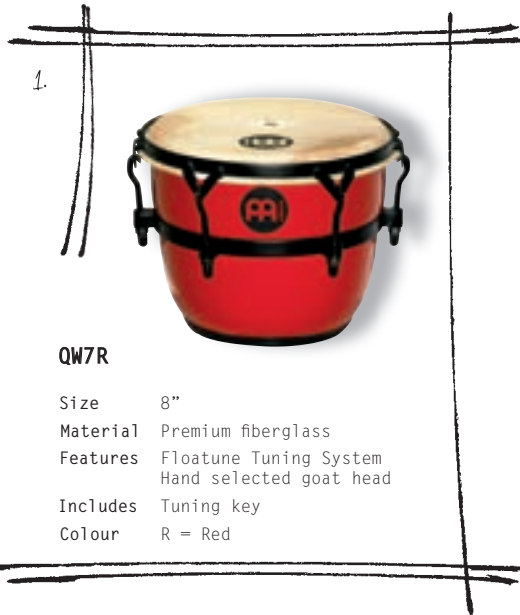

**QW7R**

Size 8"  
 Material Premium fiberglass  
 Features Floatune Tuning System  
 Hand selected goat head  
 Includes Tuning key  
 Colour R = Red

## 2.



**QW6**

**QW10**

Sizes 6"  
 10"  
 Material Aluminum  
 Features Countersunk bolt heads (QW10)  
 Hand selected goat heads  
 Includes Tuning key

*Jenny Hahn Germany*



## 3.



**MQW-6**

**MQW-10**

**MQW-7**

Sizes 6"  
 8"  
 10"  
 Material Heavy duty padded nylon  
 Features Padded shoulder strap  
 Carrying grip  
 External pocket

Reinhard Wening

Miriam Wolffskeel

Theresa Heilingloh

Luisa

Olvido Ruiz Castellanos



# Caixas

1. **CA12** **CA14**

*Lightweight aluminum*

*Professional snare throw-off mechanism*

Sizes	12" x 4 1/2" 14" x 4"
Material	Aluminum
Features	Replaceable synthetic heads Countersunk bolt heads Steel snare wires Logo applied from underneath the head (US patent) Professional snare throw-off mechanism
Includes	Tuning key

2. **CA12T**

*Traditional style with guitar strings*

*6" deep for more volume*

*See the new stand on page 109*

Size	12" x 6"
Material	Aluminum
Features	Traditional style snares made from guitar strings Extra deep body Countersunk bolt heads Logo applied from underneath the head (US patent) Replaceable synthetic heads
Includes	Tuning key

*Three arm basket stand!*

3. **MCA-12** **MCA-14** **MCA-12T**

- |          |   |
|----------|---|
| Sizes    | MCA-12: 12" x 4 1/2"<br>MCA-12T: 12" x 6"<br>MCA-14: 14" x 4"   |
| Material | Heavy duty padded nylon   |
| Features | Double-slide zipper<br>Extra pocket for spare heads<br>Shoulder strap<br>Carrying grip<br>External pocket |

*Extra pocket for spare heads*



*Dominik Muszyński & WaDaDa, Poland*

*Samba*

# Repiniques

## 1. ALUMINUM REPINIQUES (US patent)

The Repinique is played with a stick while the other hand is used for open tones and slaps. MEINL offers two sizes made from premium aluminum.

## 2. WOOD REPINIQUE (US patent)

For an especially warm and harmonic sound, MEINL offers a Repinique made from wood.

## 3. PROFESSIONAL REPINIQUE BAGS

The MEINL Repinique Bags are made from heavy duty padded nylon with reinforced stitching and are equipped with a double-slide zipper, a shoulder strap, and a carrying grip.

## 4. SAMBA BELT

MEINL offers a high quality belt to ensure a safe and comfortable playing of the Surdo and Repinique. It can be placed around the player's shoulder or hips depending on the required playing position.

1.



Logo applied from underneath the head to prevent from wearing off (US patent)



Lightweight aluminum

RE10

RE12

Sizes 10" x 10"  
12" x 12"

Material Aluminum

Features Countersunk bolt heads  
Chrome plated hardware  
Replaceable synthetic heads  
6 tuning lugs (10" model)  
8 tuning lugs (12" model)  
Logo applied from underneath the head (US patent)

Includes Tuning key



Countersunk bolt head

2.



Countersunk bolt head

RE12AB-M

Size 12" x 12"

Material Rubber Wood  
(*Hevea brasiliensis* Muell.-Arg.)

Features Countersunk bolt heads  
Chrome plated hardware  
Replaceable synthetic heads  
8 tuning lugs  
Logo applied from underneath the head (US patent)

Includes Tuning key

Colour AB = African Brown

Finish Matte

3.



MREB-10

MREB-12

Sizes 10" x 10"  
12" x 12"

Material Heavy duty padded nylon

Features Double-slide zipper  
Shoulder strap  
Carrying grip  
External pocket

Improved!!

4.



SB-R

Material Cotton

Features Length adjustable  
Adjustable shoulder padding  
Strong attachment hooks

Colour R = Red

Charly Böck, Germany



# Aluminum Surdos

For Napa Heads!!  
See page 34

- Sizes** 16" x 20"  
18" x 22"  
20" x 24"  
22" x 24"
- Material** Aluminum
- Features** Countersunk bolt heads  
Chrome plated hardware  
Replaceable synthetic heads  
8 tuning lugs  
(16" & 18" models)  
10 tuning lugs  
(20" & 22" models)  
Logo applied from underneath the head (US patent)
- Includes** Tuning key



Logo applied from underneath the head to prevent from wearing off (US patent)

2.



- Sizes** 16" x 20"  
18" x 22"  
20" x 24"  
22" x 24"
- Material** Aluminum
- Features** Height adjustable legs  
Countersunk bolt heads  
Chrome plated hardware  
Replaceable synthetic heads  
8 tuning lugs  
(16" & 18" models)  
10 tuning lugs  
(20" & 22" models)  
Logo applied from underneath the head (US patent)
- Includes** Tuning key

Height adjustable leg



All the beater you need - see page 115!!



Miguel Fenton, Canada

1. ALUMINUM SURDOS (US patent)  
The deep sound of the Surdo is the heartbeat of Samba music. It is played with a felt beater. MEINL offers several sizes made from premium aluminum.
2. STAND ALONE ALUMINUM SURDOS (US patent)  
MEINL percussion offers stand alone Surdos that are equipped with sturdy, height adjustable legs placed on the floor while playing.

# Wood Surdos

Sizes 16" x 20"  
18" x 22"  
20" x 24"  
22" x 24"

Material Six-ply hardwood shells

Features Countersunk bolt heads  
Chrome plated hardware  
Replaceable synthetic heads  
8 tuning lugs (16" & 18" models)  
10 tuning lugs (20" & 22" models)  
Logo applied from underneath the head (US patent)

Includes Tuning key

Colour AB = African Brown

Finish Matte

*Six-ply hardwood shells for a full and warm sound*

*Countersunk bolt head*



SU16AB-M

SU18AB-M

SU20AB-M

SU22AB-M

## 1. WOOD SURDOS (US patent)

The MEINL Wood Surdos have all the great features of our Aluminium Surdos, but with wooden shells for a warmer sound. They deliver the full bass notes that are the heartbeat of Samba music, and are light enough for extended play.

## 2. STAND ALONE WOOD SURDOS (US patent)

The MEINL Stand Alone Wood Surdos have all the great features of our Stand Alone Aluminium Surdos, but with wooden shells for a warmer sound. They deliver the full bass notes that are the heartbeat of Samba music. The MEINL Stand Alone Surdos are perfect for stationary playing, on stage, or in a drum circle!



SU16-L-AB-M

SU18-L-AB-M

SU20-L-AB-M

SU22-L-AB-M

## 3. NAPA HEADS

The new MEINL Napa Heads add a whole new flavor for the low-end drums. The heads feature a two-layer construction with a strong, thin mylar (plastic) underlayer, and a soft Napa surface, securely bound together in a metal hoop. The thicker surface layer dampens and softens the attack, while eliminating any unwanted higher frequencies. They are easily switched with our traditional surdo heads for a very different sound, lending a kind of surging or swelling feeling to a groove.

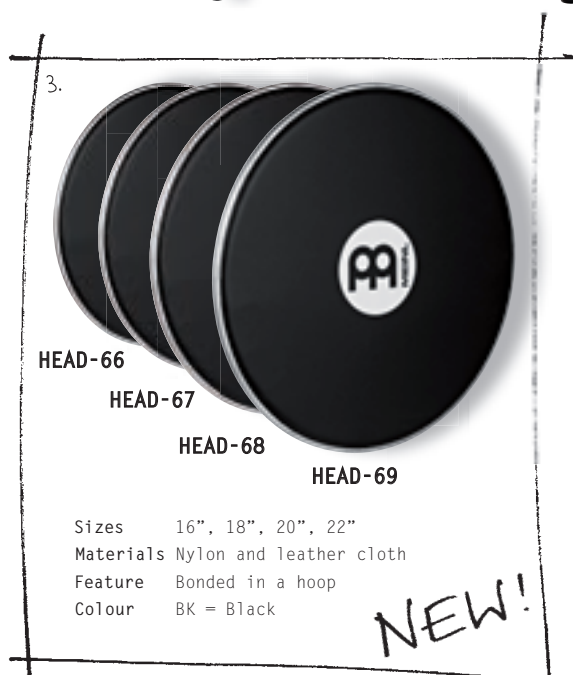

HEAD-66

HEAD-67

HEAD-68

HEAD-69

Sizes 16", 18", 20", 22"  
Materials Nylon and leather cloth  
Feature Bonded in a hoop  
Colour BK = Black

**NEW!**

Sizes 16" x 20"  
18" x 22"  
20" x 24"  
22" x 24"

Material Six-ply hardwood shells

Features Height adjustable legs  
Countersunk bolt heads  
Chrome plated hardware  
Replaceable synthetic heads  
8 tuning lugs (16" & 18" models)  
10 tuning lugs (20" & 22" models)  
Logo applied from underneath the head (US patent)

Includes Tuning key

Colour AB = African Brown

Finish Matte

# Bahia Surdos

For sticks and beaters see page 115



**Sizes** 18" x 16"  
20" x 16"  
22" x 18"

**Material** Aluminum

**Features** Countersunk bolt heads  
Chrome plated hardware  
Replaceable synthetic heads  
8 tuning lugs (18" model)  
10 tuning lugs (20" & 22" models)  
Logo applied from underneath the head (US patent)

**Includes** Tuning key



## 1. BAHIA ALUMINUM SURDOS (US patent)

The MEINL Bahia Aluminum Surdos are made to celebrate Samba-Reggae. Each surdo is cut shorter than its Rio counterpart and typically worn much lower, on a belt. Our three sizes offer two great sounding *fundos* and a higher third-surdo.

## 2. BAHIA WOOD SURDOS (US patent)

The MEINL Bahia Wood Surdos celebrate Samba-Reggae music with warm-sounding wooden shells. The three sizes offer the classic high-low *fundos* and a higher pitched third surdo. Each surdo is cut shorter than its Rio counterpart, and typically worn much lower, on a belt.

Shorter shells enable to wear in much lower position

Logo applied from underneath the head to prevent from wearing off (US patent)

## 3. PROFESSIONAL SURDO BAGS

The MEINL Surdo Bags are made from heavy duty padded nylon with reinforced stitching and are equipped with a double-slide zipper, padded backpack straps, and a carrying grip.

2.

**Sizes** 18" x 16"  
20" x 16"  
22" x 18"

**Materials** Six-ply hardwood  
Rubber Wood  
(*Hevea brasiliensis* Muell.Arg.)

**Features** Countersunk bolt heads  
Chrome plated hardware  
Replaceable synthetic heads  
8 tuning lugs (18" model)  
10 tuning lugs (20" & 22" models)  
Logo applied from underneath the head (US patent)

**Includes** Tuning key

**Colour** AB = African Brown

**Finish** Matte



For regular synthetic heads, see page 176

3. MSUB-16



**Sizes** 16" x 20"  
18" x 22"  
20" x 24"  
22" x 24"

**Material** Heavy duty padded nylon

**Features** Double-slide zipper  
Padded backpack straps  
Carrying grip  
External pocket



*Joannie Labelle, Canada*

PPA



*Juan Carlos Melian, Spain*

*Anna Törnquist, Sweden*

*Cajons*

# Headliner<sup>®</sup> Series Cajons

## 1. PROTECTION COVER FOR HEADLINER<sup>®</sup> CAJONS

The MEINL Protection Cover for Headliner<sup>®</sup> Cajons offers dependable protection at an affordable price, assuring your cajon will look as good as it sounds for a long time to come.



1.

Material Heavy duty nylon  
Colour Black

*Fits for all Headliner<sup>®</sup> Cajons*

## 2. HEADLINER<sup>®</sup> SERIES CAJONS

The MEINL Headliner<sup>®</sup> Series Cajons deliver the classic cajon sound at an affordable price and can be used in Flamenco or world music. They are also very useful during unplugged gigs for delivering the rhythmic foundation for a whole band when a full drum set can't be used.

MCJPC

*Anti-slip sitting surface*

*Adjustable sizzle effect*



*Adjustable top corners*

2.



HCAJ1AWA

*Eco-friendly medium density fiberboard*

*Stained American White Ash*



HCAJ1NT

*Heavy duty rubber feet for a solid base*



HCAJ1MH-M

**Materials**  
HCAJ1AWA  
Frontplate: Stained American White Ash (*Fraxinus Americana* L.)  
Resonating body: Eco-friendly medium density fiberboard  
HCAJ1MH-M  
Frontplate: Mahogany  
Resonating body: Rubber Wood (*Hevea brasiliensis* Muell.-Arg.)  
HCAJ1NT  
Frontplate: Rubber Wood (*Hevea brasiliensis* Muell.-Arg.)  
Resonating body: Rubber Wood (*Hevea brasiliensis* Muell.-Arg.)

**Features**  
Adjustable top corners  
Adjustable sizzle effect  
Anti-slip sitting surface

**Includes**  
Allen wrench

**Finish**  
Matte





# Headliner® Designer Series Cajons

The MEINL Headliner® Designer Series Cajons are available in six different motifs. The two cloth-covered models produce a drier and crisper sound compared to conventional bare wood construction, while the other four cajons are made out of eco-friendly medium density fiberboard with appliqué graphics.



HCAJ2-UK



HCAJ2-SK



HCAJ2-US

- Materials** HCAJ2-WD/HCAJ2-SK/HCAJ2-US/  
HCAJ2-UK: Eco-friendly medium density fiberboard with appliqué graphics  
HCAJ2-FP/HCAJ2-OC: Cloth-covered eco-friendly medium density fiberboard
- Features** Snappy graphic style  
Internal snare wires  
Adjustable top corners
- Designs** FP = Flower Power  
OC = Original Camo  
SK = Skulls Finish  
UK = Unity Finish  
US = Stars'n Stripes  
WD = White Dragon

*Eco-friendly medium density fiberboard with appliqué graphics*



*Internal snare wires*

*Flower Power*



HCAJ2-OC

*Original Camo*



HCAJ2-WD

*The Chinese characters stand for "Dragon and Fire"*



HCAJ2-FP

*Cajons*

# String Cajons

Adjustable top corners

Birch provides a sound colour with enhanced projection

bundled with bag



1A.  
CAJ3VSB-M+BAG  
bundle with MCJB

CAJ3MB-M+BAG  
bundle with MCJB



## 1. STRING CAJONS (US patent)

### 1A. STRING CAJONS BUNDLE WITH BAG (US patent)

MEINL Cajons feature a built-in adjustable sizzle effect. Strings, which touch the frontplate on the inside and span from top to bottom, deliver a sensitive rattle that can be adjusted to fit various musical applications. The patented integrated string mute system controls the tension of the strings and ensures a dry and crisp sizzle effect.

### 2. STRING FIBERGLASS CAJON (US patent)

#### 2A. STRING FIBERGLASS CAJON BUNDLE WITH BAG (US patent)

This MEINL Cajon features a frontplate made from premium fiberglass and resonating body made from Rubber Wood, resulting in a modern look and additional sound options.



- Materials** CAJ3MB-M  
Frontplate: Makah-Burl  
Resonating body: Rubber Wood  
(*Hevea brasiliensis* Muell.-Arg.)  
CAJ3VSB-M  
Frontplate: Birch  
VSB = Vintage Sunburst  
Resonating body: Rubber Wood  
(*Hevea brasiliensis* Muell.-Arg.)  
CAJ3BMB-M  
Frontplate: Black Makah-Burl  
Resonating body: Rubber Wood  
(*Hevea brasiliensis* Muell.-Arg.)
- Features** Adjustable top corners  
Adjustable sizzle effect  
Integrated string mute system  
(US patent)  
Wide sound options  
Padded sitting surface
- Includes** Allen wrench
- Finish** Matte

Heavy duty rubber feet for a solid base

2.



Premium fiberglass

2A.



- Materials** Frontplate: Premium fiberglass  
Resonating body: Rubber Wood  
(*Hevea brasiliensis* Muell.-Arg.)
- Features** Adjustable top corners  
Adjustable sizzle effect  
Integrated string mute system  
(US patent)  
Wide sound options  
Padded sitting surface
- Includes** Allen wrench

# String Designer Series Cajons

Our new String Designer Series Cajons have a fresh and stylish appeal. Organic, fluid graphics take our cajons away from the "boxy-crate" look, and move them towards elegance.

- Materials** Frontplate: Tulip Wood (*Dalbergia variabilis*)  
Resonating body: Eco-friendly medium density fiberboard with appliqué graphics
- Features** Stylish graphic designs  
Adjustable top corners  
Adjustable sizzle effect with integrated string mute system (US patent)  
Padded sitting surface  
Wide sound options
- Includes** Allen wrench
- Designs** GAF = Graphic Art Finish  
WAF = Willow Art Finish

Adjustable sizzle effect with integrated string mute system (US patent)



CAJ3GAF



CAJ3WAF

Padded sitting surface

NEW

Stylish willow art



# The Next Generation

## 1. ERGO-SHAPE STRING CAJON (Patented)

The MEINL Ergo-Shape String Cajon features an exotic Bubinga frontplate and two innovations: The frontplate is ergonomically curved for maximum comfort and sound development, and the string mute system gives your sound extra precision and control. The Bubinga frontplate is a rich and beautiful reddish coloured African wood.

1.



CAJ300BU-M

Padded sitting surface

Bubinga

Adjustable sizzle effect with integrated string mute system (US patent)



## 2. ERGO-SHAPE PEDAL CAJON (Patented)

The MEINL Ergo-Shape Pedal Cajon features our German patented ergonomic curved frontplate, made from exotic African Bubinga Wood. The ergonomically shaped frontplate has a slight curve (Ergo-Shape) that follows the natural contour of your hands for extreme comfort when playing - you will feel the difference!

2.



CAJ100BU-M

Adjustable top corners

Foot pedal for a quick on/off switch of the snare wires (US patent)



Heavy duty rubber feet for a solid base

<b>Materials</b>	Frontplate: Bubinga Resonating Body: Rubber Wood (Hevea brasiliensis Muell.-Arg.)
<b>Features</b>	Ergo-Shape (German and US patent) Adjustable sizzle effect Integrated string mute system (US patent) Adjustable top corners Padded sitting surface
<b>Includes</b>	Allen wrench
<b>Finish</b>	Matte



Ergo-Shape (German and US patent)

3.



Castanet-like striking surface (patent pending)

Inventor



Oliver Böttger

**Material** Frontplate and resonating Body: Red Oak (*Quercus rubra*)  
**Features** Castanet-like striking surface (patent pending)  
 Internal snare wires  
 Wide sound options  
 Padded sitting surface  
**Finish** Matte

CAJ4RO-M

Red Oak

### 3. TURBO CAJON (patent pending)

The MEINL Turbo Cajon goes an extra step towards cutting edge. The concept comes from instrument designer Oliver Böttger. We made this cajon with upper corners that have deeply cut channels with castanet-like striking surfaces. This produces a reinforced slap effect that you control with hand pressure.

### 4. BASS PEDAL CAJON (US patent)

A pedal attached to the cajon adjusts the amount of pressure used to press the snare wires against the front plate, and can even be turned off completely. This system allows the player to change the settings of the snare wires while playing a rhythm with both hands without interruption. Due to its size being bigger than the standard MEINL Cajons, the instrument has more projection and bass frequencies.

### 5. DELUXE BASS PEDAL CAJON BAG

The MEINL Deluxe Cajon Bag for the CAJ5 is perfectly suited for the bigger sized Bass Pedal Cajon. It features an additional layer of synthetic fur, which removes surface moisture and provides additional protection.

5.



Carrying grip

Padded shoulder strap

X Synthetic fur for additional protection

MDLXCJB-L

**Materials** Heavy duty padded nylon  
 Synthetic fur  
**Measures** 21 1/2" W x 17" H x 14 1/2" D  
**Features** Padded shoulder strap  
 External pocket  
 Carrying grip

**Materials** Frontplate: Ebony  
 Resonating body: Rubber Wood (*Hevea brasiliensis* Muell.-Arg.)  
**Features** Foot pedal (US patent)  
 Internal, adjustable snare wires  
 Great bass tones  
 Adjustable top corners  
 Padded sitting surface  
 Wide sound options  
**Finish** Matte

More volume for more bass



4.

Adjustable top corners

Foot pedal for a quick on/off switch of the snare wires (US patent)

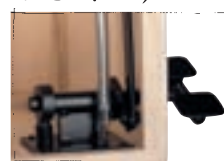

CAJ5EB-M

Heavy duty rubber feet for a solid base

Cajons

# Snare Cajons

The snares touch the frontplate from the inside and deliver the classical cajon sound, which is requisite in Flamenco music. A knurled knob adjusts the amount of pressure used to press the snare wires against the frontplate. The rattle effect ranging between light and sensitive to very loud can be achieved through adjustment. The entire snare unit can even be turned off completely.



Low Hat - made just for cajon players. (see page 117)



White Ebony

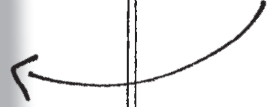

CAJIWE-M

Our cajon bags (see page 51) fit perfectly to all our snare cajons

Ray Luzier, USA



Photo by Sebastian Paquet

Thorsten Schulte

Silvia Stange

Petra Bellinger



**Materials** CAJ1BR-M  
 Frontplate: Black Rimba  
 Resonating body: Rubber Wood  
 (*Hevea brasiliensis* Muell.-Arg.)  
 CAJ1CA-M  
 Frontplate: Premium fiberglass  
 Resonating body: Rubber Wood  
 (*Hevea brasiliensis* Muell.-Arg.)  
 CAJ1EB-M  
 Frontplate: Ebony  
 Resonating body: Rubber Wood  
 (*Hevea brasiliensis* Muell.-Arg.)  
 CAJ1SNT-M  
 Frontplate: American White Ash  
 (*Fraxinus americana* L.)  
 Resonating body: Rubber Wood  
 (*Hevea brasiliensis* Muell.-Arg.)  
 CAJ1WE-M  
 Frontplate: White Ebony  
 Resonating body: Rubber Wood  
 (*Hevea brasiliensis* Muell.-Arg.)

**Features** Adjustable top corners  
 Internal, adjustable snare wires  
 Padded sitting surface  
 Wide sound options  
**Finish** Matte

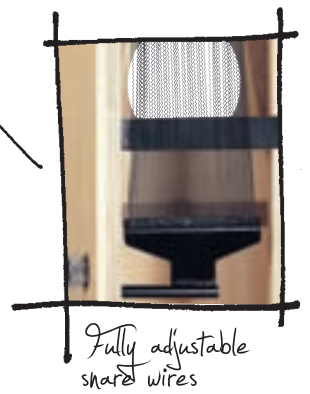
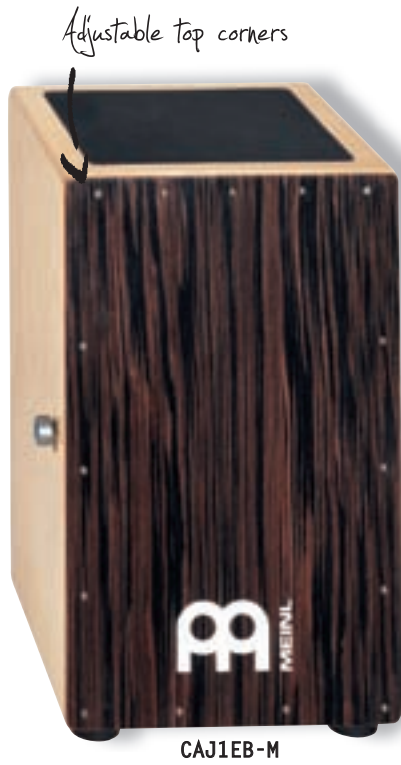

# Collection Cajons

All MEINL Collection Cajons feature elegant veneers, both for the frontplate, and for the resonating body. These cajons will attract attention in any performing situation.



- Materials**
- CAJ2BE-M  
Frontplate and resonating body: Black Ebony
  - CAJ2ELM-M  
Frontplate: Elm  
Resonating body: Rubber Wood (*Hevea brasiliensis* Muell.-Arg.)
  - CAJ20B-M  
Frontplate: Orange Burl  
Resonating body: White Burl
  - CAJ2R0-M  
Frontplate: Cherry  
Resonating body: Red Oak (*Quercus rubra*)
- Features**
- Adjustable top corners
  - Internal, adjustable snare wires
  - Padded sitting surface
  - Wide sound options
- Finish** Matte



# Pickup Cajons

The MEINL Pickup Cajons are equipped with a pickup microphone and a pre-amp system with volume control from Shadow®. This active system includes a specially designed pre-amp, high quality endpin output jack and a durable battery. The system adds very little weight to the instrument. The sound reproduction is amazingly pure and clear. This installed microphone system provides comfortable and easy handling in live situations. Plug in and play!

New pickup system from Shadow inside



Adjustable sizzle effect with integrated string mute system (US patent)

**improved**

Pickup system from Shadow inside

CAJ9SNT-M

CAJ8MB-M

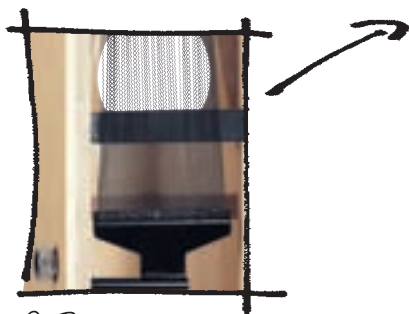

Fully adjustable snare wires

Heavy duty rubber feet for a solid base



Rear view

Active pre-amp system with volume control from Shadow

**Materials** CAJ9SNT-M  
 Frontplate: American White Ash (*Fraxinus americana* L.)  
 Resonating body: Rubber Wood (*Hevea brasiliensis* Muell.-Arg.)  
 CAJ8MB-M  
 Frontplate: Makah-Burl  
 Resonating body: Rubber Wood (*Hevea brasiliensis* Muell.-Arg.)

**Features** CAJ9SNT-M  
 Pickup microphone  
 Active pre-amp system with volume control from Shadow®  
 Adjustable top corners  
 Internal, adjustable snare wires  
 Padded sitting surface  
 Wide sound options

CAJ8MB-M  
 Pickup microphone  
 Active pre-amp system with volume control from Shadow®  
 Adjustable top corners  
 Adjustable sizzle effect with integrated string mute system (US patent)  
 Padded sitting surface  
 Wide sound options

**Includes** CAJ9SNT-M  
 9-volt battery  
 CAJ8MB-M  
 9-volt battery  
 Allen wrench

**Finish** Matte

# Specialty Cajons

## 1. TREJON

The MEINL Trejon is a breakthrough cajon development from Arend Schmidt-Landmeier. Three separate faceplates create three distinct tonal effects. It is similar to a drum set in that bass, snare, and tom sounds are in easy reach on the comfortably angled playing surface. The Ebony faceplates are exotic and stylish.

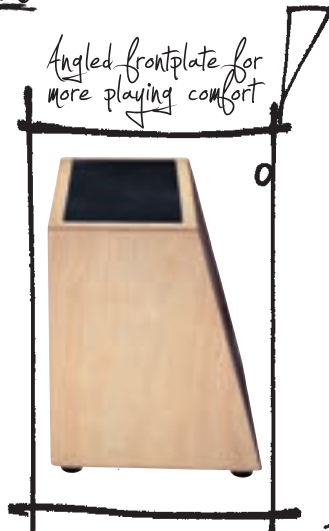

Arend Schmidt-Landmeier

Inventor

## 2. TREJON BAG

Take the fun with you wherever you go! Our Trejon bag makes it easy and comfortable to safely transport your Trejon just about anywhere! Whether it's to the park, or on tour - just go for it!

Improved

1.

Internal snare wires! (right)

Internal snare wires! (left)

- Materials** Frontplates: Ebony  
Resonating Body: Rubber Wood (*Hevea brasiliensis* Muell.-Arg.)
- Features** Three separate face plates on angled playing surface  
Two internal snare wires  
Angled frontplate for more playing comfort  
Great bass tones  
Adjustable top corners  
Padded sitting surface  
Wide sound options
- Finish** Matte

TRECAJ2EB-M

NEW!

2.

Great bass tones due to the big size

Heavy duty rubber feet for a solid base

Large pockets on each side for small percussion



MTREB

- Material** Heavy Duty padded nylon
- Measures** 21" W x 20" H x 18" D
- Features** Extra padding for security  
External pocket for small percussion  
Padded backpack straps



Ndiane

Sebastiana Da Silva



Juilen Asomts



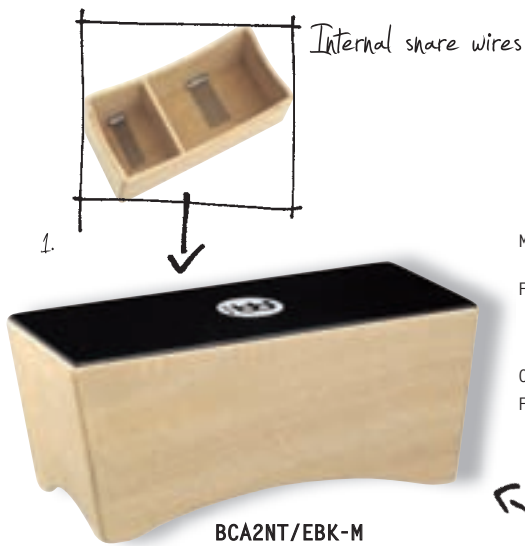

**Material** Rubber Wood  
(*Hevea brasiliensis* Muell.-Arg.)

**Features** Internal snare wires  
High- and low pitch playing surface  
Compact size and light weight

**Colour** NT/EBK-M = Natural/Ebony Black

**Finish** Matte

**1. SNARE BONGO CAJON**  
(DGBM/German Register Utility Model)

The MEINL Snare Bongo Cajon can be played like a bongo, between the legs, or on one's lap. It comes with two snares secured to the inner side of the playing surface, for an authentic cajon sound and feel.

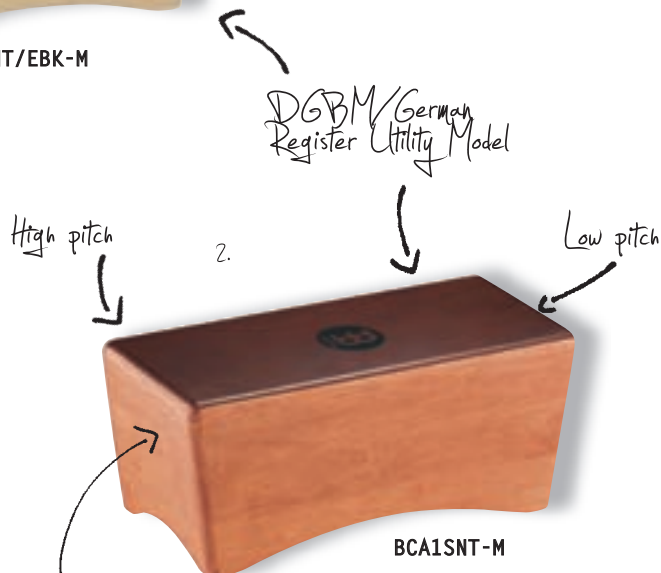

**Material** Rubber Wood  
(*Hevea brasiliensis* Muell.-Arg.)

**Features** High- and low pitch playing surface  
Compact size and light weight

**Colour** SNT-M = Super Natural

**Finish** Matte

**2. BONGO CAJON**  
(DGBM/German Register Utility Model)

The MEINL Bongo Cajon is uniquely different. It delivers the sound one can expect from a traditional cajon, and with a playing surface that has high- and low pitch sound areas, traditional bongo patterns can be played on it as well

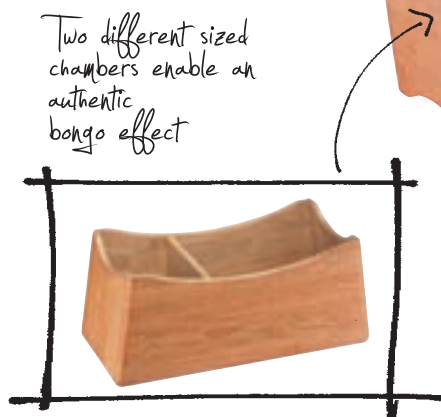

**Materials** Playing surface: Makah-Burl  
Resonating body: Rubber Wood  
(*Hevea brasiliensis* Muell.-Arg.)

**Features** Adjustable sizzle effect  
Compact size

**Includes** Allen wrench

**Finish** Matte

**3. PALITO**

The MEINL Palito is another addition to the comprehensive variety of our cajon instruments. Strings which touch the playing surface on the inside deliver a sensitive sizzle effect that fits to various musical applications. Its compact size and light weight makes it the perfect companion on the road.

Peter Schneider

Benedicte Ross

# Specialty Cajons

## 1. CAJITA

The MEINL Cajita is developed from the classic Peruvian folk instrument. It hangs from the neck and is played with a wooden striker in one hand. The other hand controls the handle on the lid, opening and closing to create a wide variety of sounds, effects, and moods.

## 2. CONGA CAJON

The MEINL Conga Cajon can fit gracefully together with congas in a traditional trio configuration, or be played on its own. It features MEINL's innovative internal and adjustable snare wire system for enhanced sound possibilities.

## 3. PROFESSIONAL CONGA CAJON BAG

The Professional Conga Cajon Bag stores this valuable instrument securely and prevents it from being damaged during travel.

## 4. CONGA CAJON STAND (patented)

The MEINL Conga Cajon Stand has many of the same features as the Steely II Conga Stands (patented). It was designed to enable a comfortable placement of MEINL Conga Cajon when played by itself or when incorporating it into a percussion rig.

**Materials** Playing surface: Black Makah-Burl  
Resonating Body: Rubber Wood  
(*Hevea brasiliensis* Muell.-Arg.)  
**Features** Internal, adjustable snare wires  
Adjustable top corners  
**Finish** Matte

The Meinl Conga Cajon won the MIPA Award in the "Best Percussion Product" category.



CCA1NT

**Material** Rubber Wood  
(*Hevea brasiliensis* Muell.-Arg.)  
**Features** Soft nylon cord  
Solid piano hinge  
Easy-grip handle  
**Includes** Wooden striker  
**Finish** Matte

Fully adjustable snare wires

2.

Black Makah-Burl



CAJ10TBW-M

3.



MCJB-D

**Material** Heavy duty padded nylon  
**Features** Padded shoulder strap  
External pocket  
Carrying grip

4.

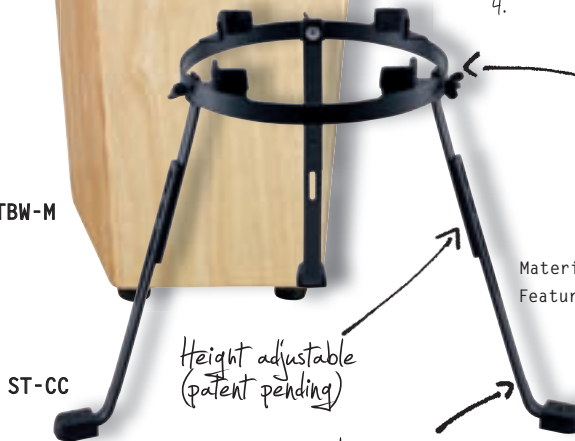

ST-CC

Height adjustable (patent pending)

L-shaped leg (patented\*)

U-shaped notch allows quick set up and breakdown (US patent)

**Material** Black powder coated  
**Features** Metal spike attached to each leg  
L-shaped legs (patented)  
U-shaped notch for quick set up and breakdown (US patent)  
Notches for quick height adjustability (patent pending)  
**Includes** Allen wrench

\* Germany, United States, Thailand



Pablo

Boris Kellermann



# Cajon Bags

Material Heavy duty padded nylon  
 Measures 20 1/2" W x 12" H x 12" D  
 Features Padded shoulder strap  
 External pocket  
 Carrying grip

MCJB



## 1. PROFESSIONAL CAJON BAG

The MEINL Cajon Bag is the perfect solution for transporting these valuable instruments. Its heavy duty padded outside walls store it securely and prevents damage.

## 2. DELUXE CAJON BAG

The MEINL Deluxe Cajon Bag features an additional layer of synthetic fur, which removes surface moisture and provides extra protection. Additional features are a padded shoulder strap and an external pocket for accessories.

X Synthetic fur for additional protection

2.



MDLXCJB

Material Heavy duty padded nylon  
 Synthetic fur  
 Measures 20 1/2" W x 12" H x 12" D  
 Features Padded shoulder strap  
 External pocket  
 Carrying grip

## 3. DESIGNER CAJON BAG

The MEINL Designer Cajon Bag is available in Original Camo. Handy grips and shoulder strap makes it easy to carry.

3.

MCJB-C1



Material Heavy Duty padded nylon  
 Measures 20 1/2" W x 12" H x 12" D  
 Features Padded shoulder strap,  
 External pocket  
 Carrying grip  
 Colour C1 = Original Camo



Engin Gurkey, Turkey

Janika Herz

Rudi





Taku Hirano, USA



Marcie Chapa, USA

Sabine Vieten,  
Germany

# Congas

# Headliner® Series Congas

## 10" & 11" WOOD CONGA SETS

The 10" & 11" pair is the perfect set of congas to get you started! The compact size is easy for young players to handle, light to carry, and has a full, rich sound. You can develop a full foundation of conga techniques and rhythms with these student-friendly drums.

*Fresh and modern look*

HC555HPF

**NEW!**

*Rubber ringed bottom for more stability and protection when played without stand*



*Original MEINL style tuning bracket*



*Height adjustable*

*L-shaped leg (German patent)*

- Sizes 10" & 11" Conga Set  
28" tall
- Material Rubber Wood  
(*Hevea brasiliensis* Muell.-Arg.)
- Features Hand selected buffalo heads  
8 mm strong tuning lugs  
Original MEINL style tuning brackets  
2 mm rounded rims  
Black powder coated hardware
- Includes Height adjustable basket stands  
(patented) with quick set up system  
Tuning key
- Colours BK = Black  
HPF = Hot Pink Fade  
NT = Natural  
VSB = Vintage Sunburst  
WRB = Wine Red Burst
- Finish High gloss

MeIer Avci

Ramona Gnap

Marina Sherbinina





HC555NT

Black powder coated 2 mm rounded rim

U-shaped notch allows quick set up and breakdown (US patent)



HC555WRB

Ergonomic arched rubber bracing for more stability (US patent)



HC555BK



HC555VSB



Olivier Verger

*Congas*

HEADLINER® SERIES CONGAS  
10" & 11" WOOD CONGA SETS

# Headliner® Series Congas

## 11" & 12" WOOD CONGA SETS

The 11" & 12" pair is a full-sized entry level conga set. They have superb projection, warm tones, light weight and features found on professional congas. They offer outstanding quality and great value in the budget price range. This is a pair of congas you will want to keep around as you develop your skills.

HC512PW

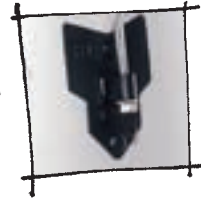

Original  
MEINL style  
tuning bracket

HC512VSB



Ergonomic arched  
rubber bracing for  
more stability  
(US patent)

HC512MA



U-shaped notch  
allows quick set up  
and breakdown  
(US patent)



L-shaped leg  
(German patent)



Height adjustable

Sizes	11" & 12" Conga Set 28" tall
Material	Rubber Wood ( <i>Hevea brasiliensis</i> Muell.-Arg.)
Features	Hand selected buffalo heads 8 mm strong tuning lugs Original MEINL style tuning brackets 2 mm rounded rims Black powder coated hardware
Includes	Height adjustable basket stands (patented) with quick set up system Tuning key
Colours	BSF = Blue Sky Fade MA = Maple NT = Natural PW = Pearl White VSB = Vintage Sunburst WRB = Wine Red Burst
Finish	High gloss

Black powder coated  
2 mm rounded rim

All 12" congas are equipped with six tuning  
lugs for better tuning consistency

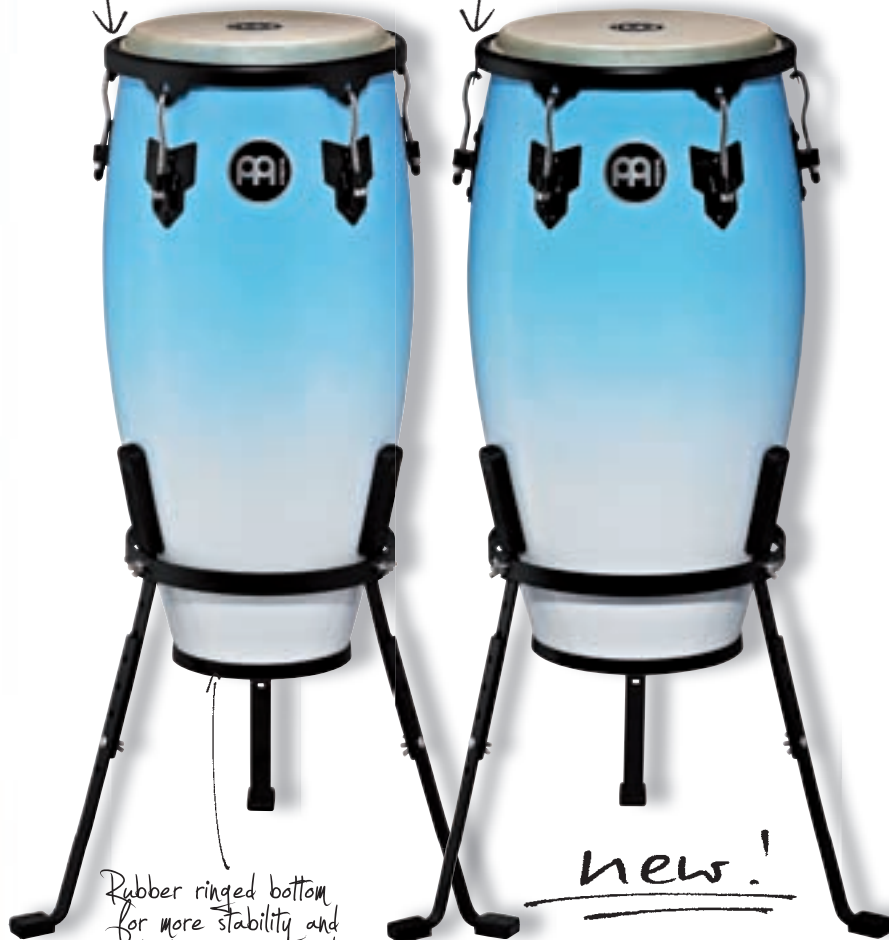

HC512BSF

HC512NT



HC512WRB

*Congas*

# Headliner® Designer Series Congas

The MEINL Headliner® Designer Series Congas are offered individually, and you can make up a trio of the three singles: Nino, Quinto and Conga. These three sizes create a full tonal range. Headliner® Designer Series Congas are available in four exciting finishes.



Stephan Horras

Nina Schneider

Patrick Priesnitz

Paweł



**Sizes** 10" Nino, 11" Quinto, 12" Conga  
28" tall

**Material** Cloth-covered Rubber Wood  
(*Hevea brasiliensis* Muell.-Arg.)

**Features** Hand selected buffalo heads  
8 mm strong tuning lugs  
Original MEINL style tuning brackets  
2 mm rounded rims  
Black powder coated hardware

**Includes** Height adjustable basket stands  
(patented) with quick set up system  
Tuning key

**Designs** AD = Art Deco  
MDC = Midnight Desert Camo

**Finish** High gloss

Pablo Bendayan

Katrina Martinez

Zarubin Andrey

Udu



*Congas*

HEADLINER® DESIGNER SERIES CONGAS

# Headliner® Designer Series Congas

The MEINL Headliner® Designer Series Congas are offered individually, and you can make up a trio of the three singles, nino, quinto and conga. These three sizes create a full tonal range.

**NEW!**



- Sizes 10" Nino, 11" Quinto, 12" Conga  
28" tall
- Material AI = Cloth-covered Rubber Wood  
(*Hevea brasiliensis* Muell.-Arg.)  
KF = Rubber Wood with appliqué graphics  
(*Hevea brasiliensis* Muell.-Arg.)
- Features Hand selected buffalo heads  
8 mm strong tuning lugs  
Original MEINL style tuning brackets  
2 mm rounded rims  
Black powder coated hardware
- Includes Height adjustable basket stands  
(patented) with quick set up system  
Tuning key
- Designs AI = Army Issue, matte  
KF = Kilt Finish, high gloss



Anna-Patricia Rickok

Jorge Bermudez, USA

Katharina Abt

Michael

Markus Wickel



# NEW!

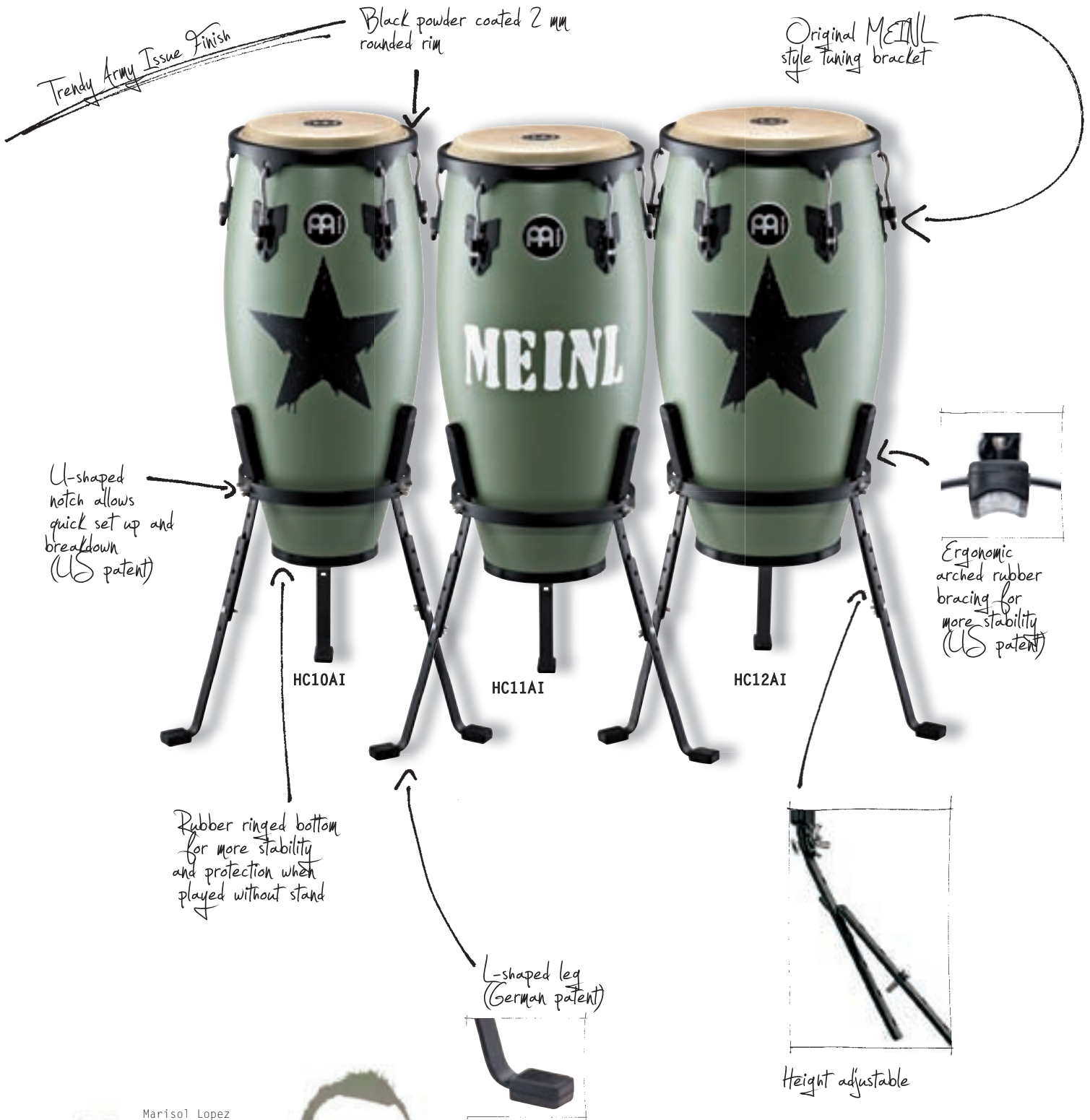

Marisol Lopez

Tobias Toal

Andreas Nunn

# Headliner® Fiberglass Series Congas

The new Headliner® Series Congas now come in premium fiberglass! This material has long been used for conga shells because of its durability and resistance to climactic changes, while offering a full spectrum and brilliance in sound.

NEW!

Hand selected buffalo heads

Made out of lightweight and durable fiberglass →

U-shaped notch allows quick set up and breakdown (US patent) →

L-shaped leg (German patent)



HFC10BK

HFC11BK

HFC12BK



Height adjustable

- Sizes 10" Nino, 11" Quinto, 12" Conga  
28" tall
- Material Premium Fiberglass
- Features Hand selected buffalo heads  
8mm strong tuning lugs  
Original MEINL style tuning brackets  
2mm rounded rims  
Black powder coated hardware
- Includes Height adjustable basket stands (patented) with quick set up system  
Tuning key
- Color BK = Black

Jenny



Aurélie Mattié



Jean-Lue Mattié





# Artist Series Congas

All of Luis' needs have been met and exceeded with the MEINL Artist Series Luis Conte Signature Congas. They combine the charm and sound of the old traditional Cuban drums with modern features and innovations. These congas are equipped with traditional rims, are mounted as close to the shell as possible, and when combined with MEINL's True Skin Buffalo Heads, they enable an even more controlled sound.



Black powder coated  
4 mm traditional TTR-Rim

*L. Conte*



LC11NT-M

LC1134NT-M

LC1212NT-M

Rubber ringed bottom for more stability and protection



Luis Conte, USA

- Sizes 11" Quinto, 11 3/4" Conga, 12 1/2" Tumba  
30" tall
- Material Two ply Rubber Wood  
(*Hevea brasiliensis* Muell.-Arg.)
- Features True Skin Buffalo Heads  
8 mm strong tuning lugs  
4 mm traditional TTR-Rims  
Black powder coated hardware
- Includes MEINL Conga Saver (patented)  
MEINL Soundpads  
Accessory pouch  
L-shaped tuning key  
Tune Up Oil
- Colour NT-M = Natural
- Finish Matte



The Meinl Artist Series Congas (Luis Conte) won the MIPA Award in the "Best Percussion Product" category.

Kuzminich Yana

Renate Schramm

Rudaff Schramm

\*in United States, China, Thailand



*Congas*

# Marathon<sup>®</sup> Classic Series Congas

The MEINL Marathon<sup>®</sup> Classic Series Congas set the standard in this price range by which other wood congas are judged. They combine professional features at a very attractive price.



Black powder coated 2.6 mm rounded SSR-Rim

Ergonomic arched rubber bracing for more stability (US patent)



- Sizes** 11" Quinto, 11 3/4" Conga, 12 1/2" Tumba, 30" tall
- Material** Two ply Rubber Wood (*Hevea brasiliensis* Muell.-Arg.)
- Features** True Skin Buffalo Heads, 8 mm strong tuning lugs, 2.6 mm rounded SSR-Rims, Black powder coated hardware
- Includes** Steely II Conga Stand (patented), MEINL Conga Saver (patented), Accessory pouch, L-shaped tuning key, Tune Up Oil
- Colours** CB = Coffee Burst, high gloss, SNT-M = Super Natural, matte

\* in United States, China, Thailand

\*\* United States and Germany



# Marathon® Designer Series Congas

The Marathon® Designer Series Congas are made with a special lacquering technique in high gloss, have professional features and are available at a very attractive price.



Black powder coated 2.6 mm rounded SSR-Rim

NEW!



MCC11AF

MCC1134AF

MCC1212AF

Ergonomic arched rubber bracing for more stability (US patent)

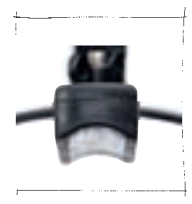

Impressive Leopard Burl finish



MCC11LB

MCC1134LB

MCC1212LB

- Sizes 11" Quinto, 11 3/4" Conga, 12 1/2" Tumba, 30" tall
- Material Two ply Rubber Wood (Hevea brasiliensis Muell.-Arg.)
- Features True Skin Buffalo Heads, 8 mm strong tuning lugs, 2.6 mm rounded SSR-Rims, Black powder coated hardware
- Includes Steely II Conga Stand (patented), MEINL Conga Saver (patented), Accessory pouch, L-shaped tuning key, Tune Up Oil
- Colours AF = Amber Flame, LB = Leopard Burl
- Finish High gloss

Congas

# Marathon® Designer Series Congas

The MEINL Marathon Designer Series Congas take the look and style to new places! Our snappy appliqué graphics set new standards in the industry.



MEINL Percussion was founded in 1978



Island Sunset finish sets the mood



- Sizes 11" Quinto, 11 3/4" Conga, 12 1/2" Tumba 30" tall
- Material Rubber Wood with appliqué graphics (Hevea brasiliensis Muell.-Arg.)
- Features True Skin Buffalo Heads  
8 mm strong tuning lugs  
2.6 mm rounded SSR-Rims  
Black powder coated hardware
- Includes Steely II Conga Stand (patented)  
MEINL Conga Saver (patented)  
Accessory pouch  
L-shaped tuning key  
Tune Up Oil
- Colours CAN = Calypso Night  
IS = Island Sunset  
MS = Mega Star  
VR = Vintage Racer
- Finish High gloss

MCC11IS

MCC1134IS

MCC1212IS





Mega Star finish shines on

MCC11MS

MCC1134MS

MCC1212MS



Black powder coated 2.6 mm rounded SSR-Rim

Heat up the dance floor with our Calypso Night finish



Ergonomic arched rubber bracing for more stability (US patent)



MCC11CAN

MCC1134CAN

MCC1212CAN

Congas

MARATHON® DESIGNER SERIES CONGAS

# Mitsudomoe NEW!

This Marathon® Designer Series Congas matches Taku Hirano's playing style: elegant, captivating and versatile. The congas are proudly emblazoned with the Japanese Mitsudomoe symbol, representing Man, Earth, and Heaven. The symbol became associated with the Samuri ethos, and with the art of drumming itself. Taku explains, "The Mitsudomoe symbol has always resounded with me in that it was a link to my heritage and synonymous to not only the warriors of Japan, but also the drummers of Japan. After doing research and finding out that it was adopted by a king with the same name as myself, and that it symbolized upholding honor to the highest degree, I knew that it chose me as much as I chose it."



MCC11M

MCC1134M

MCC1212M

- Sizes 11" Quinto, 11 3/4" Conga, 12 1/2" Tumba, 30" tall
- Material Rubber Wood with appliqué graphics (*Hevea brasiliensis* Muell.-Arg.)
- Features True Skin Buffalo Heads, 8 mm strong tuning lugs, 2.6 mm rounded SSR-Rims, Black powder coated hardware
- Includes Steely II Conga Stand (patented), MEINL Conga Saver (patented), Accessory pouch, L-shaped tuning key, Tune Up Oil
- Design M = Mitsudomoe
- Finish High gloss



Taku Hirano, USA

The Mitsudomoe (mee-tsoo-DO-mo-ay) is a symbol in the Japanese Shinto religion, representing Man, Earth, and Heaven.

# Love, Peace & Unity NEW!

Marcie Chapa sends an important message to the world with the Marathon® Designer Series Congas: "Love, Peace & Unity" "I fall in love with music each time I play." says Marcie. "Peace reminds me of where we should be. Every time I play I feel at Peace. Music has amazing powers because it is an international language that can bring Peace, Love, and Unity to us all."

"Music puts me at peace and I fall in love with it, each time I play."



MCC11LPU

MCC1134LPU

MCC1212LPU



Marcie Chapa USA

- Sizes 11" Quinto, 11 3/4" Conga, 12 1/2" Tumba 30" tall
- Material Rubber Wood with appliqué graphics (Hevea brasiliensis Muell.-Arg.)
- Features True Skin Buffalo Heads 8 mm strong tuning lugs 2.6 mm rounded SSR-Rims Black powder coated hardware
- Includes Steely II Conga Stand (patented) MEINL Conga Saver (patented) Accessory pouch L-shaped tuning key Tune Up Oil
- Design LPU = Love, Peace & Unity
- Finish High gloss

Design inspired by Marcie Chapa



Congas

MITSUDOMOE (Taku Hirano)  
LOVE, PEACE & UNITY (Marcie Chapa)

# Professional Series Congas

The Roland Meinl Professional Series Congas - one of the finest instruments in the MEINL Percussion program and the preferred conga model by many top congueros. Outstanding in look and sound, they reach from fat basses to cutting slaps with a great warm overall tone. They set the standard in the professional conga ranges.



MP11BB

MP1134BB

MP1212BB

- Sizes 11" Quinto, 11 3/4" Conga, 12 1/2" Tumba 30" tall
- Material Two ply Rubber Wood (*Hevea brasiliensis* Muell.-Arg.)
- Features True Skin Buffalo Heads 10 mm strong tuning lugs 4 mm rounded SSR-Rims Chrome plated hardware
- Includes MEINL Conga Saver (patented) MEINL Soundpads Accessory pouch L-shaped tuning key Tune Up Oil
- Colours ARF = Aztec Red Fade BB = Brown Burl NT = Natural
- Finish High gloss



Jen Lowe, USA



Milos Vacik, Czech Republic

\* United States, China, Thailand







MP11NT

MP1134NT

MP1212NT



Chrome plated 4 mm rounded SSR-Rim



The Meinl Professional Series Congas won the MIPA Award in the Best Percussion Product category.



MP11ARF

MP1134ARF

MP1212ARF

# Fibercraft Series Congas

MEINL Fibercraft Congas offer great quality, durability, volume, and they are resistant to climatic changes. They have a great presence and brilliance in sound. Great for live playing and extensive road use.



FC11BSP

FC1134BSP

FC1212BSP

*Extraordinary sparkling effect*



FC111RSP

FC1134RSP

FC1212RSP



FC11BKSP

FC1134BKSP

FC1212BKSP

- Sizes 11" Quinto, 11 3/4" Conga, 12 1/2" Tumba, 30" tall
- Material Premium fiberglass
- Features True Skin Buffalo Heads, 10 mm strong tuning lugs, 4 mm rounded SSR-Rims, Chrome plated hardware
- Includes MEINL Conga Saver (patented), MEINL Soundpads, Accessory pouch, L-shaped tuning key, Tune Up Oil
- Colours BKSP = Black Sparkle, BSP = Blue Sparkle, RSP = Red Sparkle

# Fibercraft Designer Series Congas

The MEINL Fibercraft Designer Series Congas come in a dazzling carbon finish. These congas are made from premium fiberglass for dependability and great sound characteristics.



10 mm strong tuning lugs

Durable premium fiberglass



FC11CA

FC1134CA

FC1212CA

- Sizes 11" Quinto, 11 3/4" Conga, 12 1/2" Tumba, 30" tall
- Material Premium fiberglass
- Features True Skin Buffalo Heads, 10 mm strong tuning lugs, 4 mm rounded SSR-Rims, Chrome plated hardware
- Includes MEINL Conga Saver (patented), MEINL Soundpads, Accessory pouch, L-shaped tuning key, Tune Up Oil
- Colour CA = Carbon finish

Crisp and clean carbon finish



Jan Delay, Germany

Congas

# Floatune Series Congas

The MEINL Floatune Tuning System is a true and unique MEINL innovation. All mounting hardware is completely isolated from the shell. This avoids the need to drill through the shell and mount hardware with bolts, which reduces the resonant vibrations of the shell. The Floatune Tuning System tunes up just like lug-equipped congas, only with an improved sound.



Melanie Schützner

\* United States, China, Thailand

- Sizes 10" Nino, 11" Quinto, 12" Conga, 13" Tumba, 30" tall
- Material Two ply Rubber Wood (Hevea brasiliensis Muell.-Arg.)
- Features Floatune Tuning System, True Skin Buffalo Heads, 10mm strong tuning lugs, 4mm rounded SSR-Rims, Chrome plated hardware
- Includes MEINL Conga Saver (patented), MEINL Soundpads, Accessory pouch, L-shaped tuning key, Tune Up Oil
- Colour BB = Brown Burl
- Finish High gloss

Edvaldo Oliveira

Saulo Vinicius Britto

Geraldo Mueller



# Artist Series Congas

Ramon "Mongo" Santamaria was without a doubt one of the most respected conga players ever, and a pioneer of modern Latin Jazz. During the 50's his band "Black Cuban Diamonds" laid down the foundation for an outstanding career.

Ramon recorded dozens of legendary percussion albums. Worldwide Jazz hits, such as "Watermelon Man" in 1963 and the album "Summertime" from 1980 are only two of the many recordings from this great master percussionist. Mongo has inspired more percussionists around the globe than any other conguero.

Mongo Santamaria died at the Baptist Hospital in Miami, USA in February 2003. He was 85 years old. It is with great appreciation and deepest respect that we honour our friend and his life's work with his MEINL Artist Series Mongo Santamaria Congas.



Ramon "Mongo" Santamaria, Cuba

- Sizes 11" Quinto, 11 3/4" Conga, 12 1/2" Tumba 30" tall
- Material Two ply American White Ash (*Fraxinus americana* L.)
- Features True Skin Buffalo Heads 10 mm strong tuning lugs 4 mm rounded SSR-Rims Gold tone hardware
- Includes MEINL Conga Saver (patented) MEINL Soundpads Accessory pouch L-shaped tuning key Tune Up Oil
- Colour AWA = American White Ash
- Finish High gloss



Mongo Santamaria

MSA11AWA

MSA1134AWA

MSA1212AWA

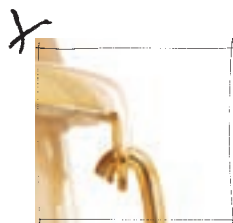

Gold tone 4 mm rounded SSR-Rim



Two ply American White Ash

\* United States, China, Thailand

Congas

FLOATUNE SERIES CONGAS  
ARTIST SERIES CONGAS (Mongo Santamaria)

# Woodcraft Series Congas

The MEINL Woodcraft Series Congas stand for tradition combined with exceptional workmanship. Only the finest hand selected materials are used to produce these premium drums. Their "Cuban Style" shells provide a broad range of different tonal characteristics.



WC117FA-M

WC1134ZFA-M

WC1212ZFA-M

- Sizes 11" Quinto, 11 3/4" Conga, 12 1/2" Tumba, 30" tall
- Material Two ply American White Ash (*Fraxinus americana* L.)
- Features True Skin Buffalo Heads, 10 mm strong tuning lugs, 4 mm traditional TTR-Rims, Chrome plated hardware
- Includes MEINL Conga Saver (patented), MEINL Soundpads, Accessory pouch, L-shaped tuning key, Tune Up Oil
- Colours AMB = Antique Mahogany Burst, high gloss, ZFA-M = Zebra Finished Ash, matte

Traditional, "Cuban Style" shell for enhanced volume

\* United States, China, Thailand

Juli Metzger

Patrick Rudolph

Benjamin Braun

Salvador Morrone and friends



NEW!



WC11AMB

WC1212AMB

WC1134AMB

Luxurious Antique Mahogany Burst Finish



Ramon Yslas, USA

Katrin Lehr

Helga Weimer



*Congas*

WOODCRAFT SERIES CONGAS

# Stands & Bags

## 1. STEELY II CONGA STANDS (patented)

The MEINL Steely II Conga Stands are available for all MEINL Professional Series Congas.

### MODELS:

For Marathon® Classic/ Designer Series  
 For Luis Conte Artist Series  
 ST-MCC11BK 11"  
 ST-MCC1134BK 11 3/4"  
 ST-MCC1212BK 12 1/2"  
 Black powder coated

For Floatune Series  
 ST-FL10CH 10"  
 ST-FL11CH 11"  
 ST-FL12CH 12"  
 ST-FL13CH 13"  
 Chrome plated

For Professional Series  
 For Fibercraft Series  
 ST-MP11CH 11"  
 ST-MP1134CH 11 3/4"  
 ST-MP1212CH 12 1/2"  
 Chrome plated

For Mongo Santamaria Artist Series  
 ST-MSA11G 11"  
 ST-MSA1134G 11 3/4"  
 ST-MSA1212G 12 1/2"  
 Gold tone

For Woodcraft Series  
 ST-WC11CH 11"  
 ST-WC1134CH 11 3/4"  
 ST-WC1212CH 12 1/2"  
 Chrome plated

## 2. STEELY II CONGA STAND HEIGHT EXPANDER SETS (patent pending)

These innovative add-ons to the MEINL Steely II Conga Stands allow an easy and effective height extension, which provides a more comfortable playing position for taller congueros.

## 3. PROFESSIONAL CONGA STAND (US patent)

The MEINL Conga Stand is unique with respect to design and function. It was especially developed to accommodate the rigors of professional road use, where fine adjustment and durability are demanded.

Ergonomic arched rubber bracing for more stability (US patent)

U-shaped notch allows quick set up and breakdown (US patent)



L-shaped leg and metal spike attachment (patented\*)

Quick and easy height adjustability (patent pending)

Material Steel  
 Features Metal spike attachment on each leg  
 L-shaped legs  
 U-shaped notch for quick set up and breakdown  
 Notches for quick height adjustability  
 Includes Allen wrench

\* Germany, United States, Thailand

Easy and effective height extension



Material Steel  
 Feature Easy and effective height extension  
 Includes Mounting screws  
 Allen wrench  
 Finishes Black powder coated  
 Chrome plated  
 Gold tone

Compatible for all sizes



The lightweight stand can be folded to a compact unit which requires little space (US patent)

Material Chrome plated steel  
 Features Unique design  
 Rubber padded crossbeams  
 Fully height adjustable  
 Folds up to a compact unit  
 Includes Allen wrench  
 Memory locks





Additional upright zipper

#### 4. PROFESSIONAL CONGA BAGS

The MEINL Conga Bags come in three sizes: Quinto, Conga, and Tumba. An extra top zipper simplifies packing and unpacking of your drum. Additional features are padded backpack straps and an external pocket for accessories.

4.



MCOB-11

MCOB-1212

MCOB-1134

#### 5. CONGA SOUND PLATE

The MEINL Conga Sound Plate is a sturdy wooden disc that provides a hard sound reflective surface under your conga. This is ideal for extra projection, especially when playing on a soft surface such as a carpet.



Carrying grip

Sizes	11" 11 3/4" 12 1/2"
Material	Heavy duty padded nylon
Features	Additional upright zipper External pocket Padded backpack straps Carrying grip

Padded backpack strap

5.

Fits under any conga!



CSP

Material	Rubber Wood ( <i>Hevea brasiliensis</i> Muell.-Arg.)
Size	13 1/4"

*Congas*



José J. Cortijo, Germany

Stephan Maass, Austria

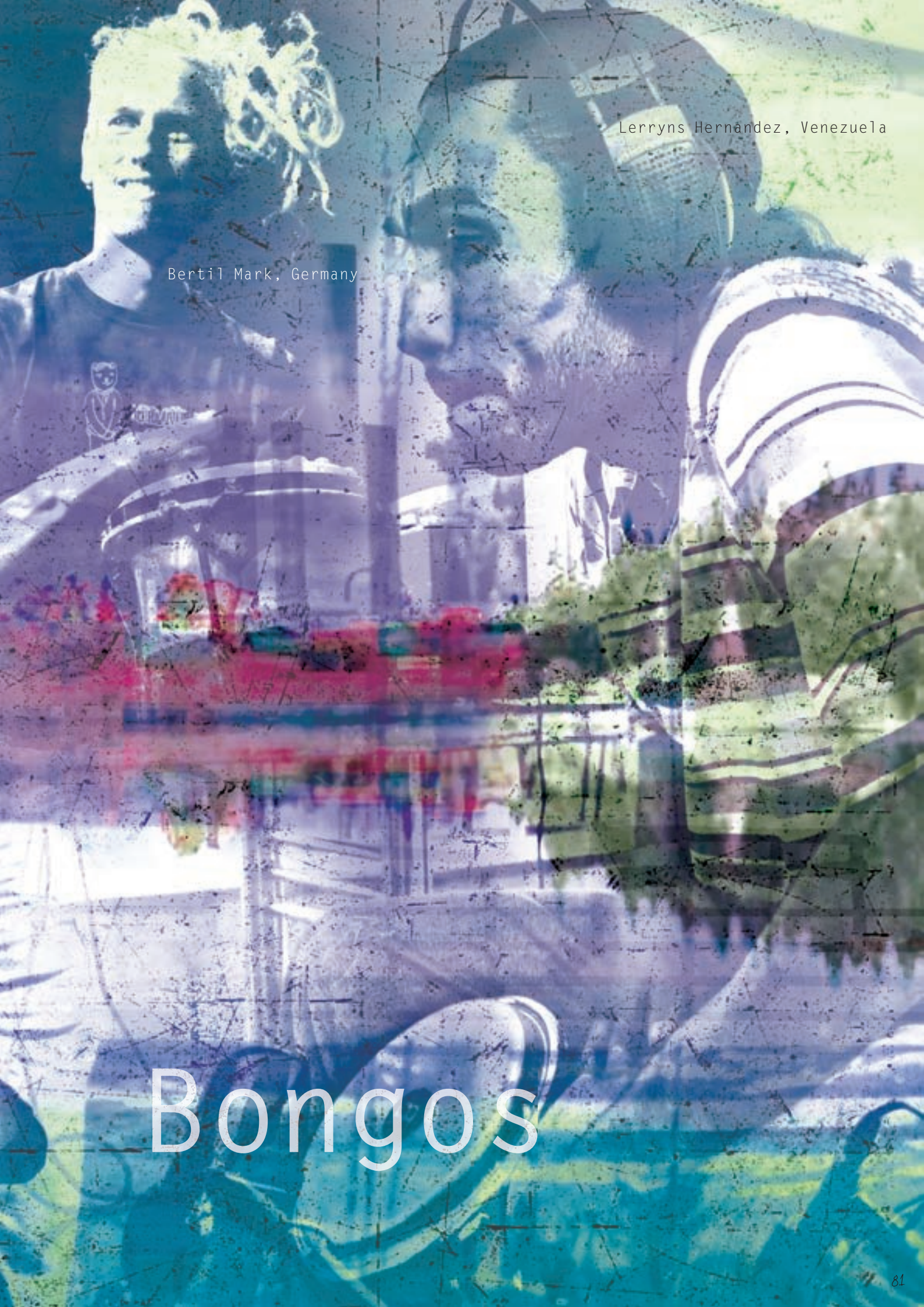

Lerryys Hernández, Venezuela

Bertil Mark, Germany

# Bongos

# Headliner® Series Bongos

## 1. HEADLINER® SERIES ABS BONGO

The MEINL Headliner® Series ABS Bongo has the features of traditional bongos, made from sturdy ABS plastic. The compact size makes them handy and portable.

1.

The compact size makes them handy and portable



HB50BK

Sizes 6 1/2" Macho & 7 1/2" Hembra  
 Material ABS plastic  
 Features Hand selected buffalo heads  
 Rounded rims for playing comfort  
 Black powder coated hardware  
 Includes Tuning key  
 Colour BK = Black

## 2. Crystal clear acrylic shells



HB50A

Sizes 6 1/2" Macho & 7 1/2" Hembra  
 Material Acrylic  
 Features Hand selected buffalo heads  
 Rounded rims for playing comfort  
 Black powder coated hardware  
 Includes Tuning key  
 Finish Transparent

## 2. HEADLINER® SERIES ACRYLIC BONGO

The MEINL Headliner® Series Acrylic Bongo has a great look. The crystal clear acrylic shells add a touch of transparency and lightness. The shells are joined together in the traditional style.

## 3. HEADLINER® SERIES WOOD BONGOS

MEINL Headliner® Series Bongos are perfect for the student or hobbyist who is looking for a high quality instrument right from the beginning.

3.



HB100BSF



HB100HPF

Includes Tuning key  
 Finish Transparent **NEW!**

**NEW!**



HB100PW



HB100WRB



HB100VSB



HB100MA

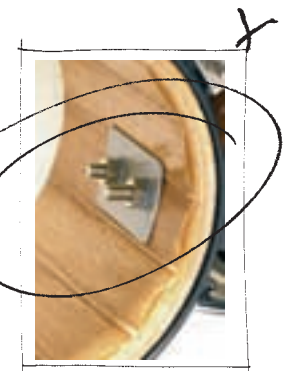

Interior backing plate adds strength to construction

Black powder coated 2 mm rounded rim



HB100NT

Traditional solid woodblock connection

Sizes 6 3/4" Macho & 8" Hembra  
 Material Rubber Wood (Hevea brasiliensis Muell.-Arg.)  
 Features Hand selected buffalo heads  
 8 mm strong tuning lugs  
 2 mm rounded rims  
 Black powder coated hardware  
 Interior backing plates  
 Includes Tuning key  
 Colours BSF = Blue Sky Fade  
 HPF = Hot Pink Fade  
 MA = Maple  
 NT = Natural  
 PW = Pearl White  
 VSB = Vintage Sunburst  
 WRB = Wine Red Burst  
 Finish High gloss

4.



HFB100BK

*Premium fiberglass!*

Sizes 6 3/4" Macho & 8" Hembra  
 Material Premium Fiberglass  
 Features Hand selected buffalo heads  
 8 mm strong tuning lugs  
 2mm rounded rims  
 Black powder coated hardware  
 Includes Tuning key  
 Colour BK = Black

**NEW!**

4. HEADLINER® FIBERGLASS BONGO

The Headliner® Fiberglass Bongo has all the traditional features and sounds of a bongo, yet in a rugged and stable premium fiberglass body. It's a perfect set for the student or hobbyist who is looking for durability from their drum.

5. HEADLINER® DESIGNER SERIES BONGOS

The MEINL Headliner® Designer Series Bongos offer two exciting finishes. The construction is in the traditional style, with a solid woodblock connection.

5.



HB100AI



HB100KF

6. BONGO BAG

The MEINL standard Bongo Bag offers dependable protection at an affordable price making transportation as hassle free as possible.



HB100MDC



HB100AD

*Stylish Art Deco finish*

Sizes 6 3/4" Macho & 8" Hembra  
 Material Cloth-covered Rubber Wood  
 (*Hevea brasiliensis* Muell.-Arg.)  
 Features Hand selected buffalo heads  
 Rounded rims for playing comfort  
 Black powder coated hardware  
 Includes Tuning key  
 Colours AD = Art Deco, high gloss  
 AI = Army Issue, matte  
 KF = Kilt Finish, high gloss  
 MDC = Midnight Desert Camo, high gloss

6.



MSTBB

Size Bongos up to 7 1/2" Macho & 8 1/2" Hembra  
 Material Heavy duty padded nylon  
 Features Padded shoulder strap  
 Carrying grip



*Peppe Sannino, Italy*



*Bongos*

# Free Ride Series Wood Bongos

NEW!

## 1. FREE RIDE DESIGNER SERIES WOOD BONGOS (German patent)

The Free Ride Designer Series Wood Bongo comes in four superb finishes. All other features are similar to the FWB190 Wood Bongos.



FWB190LB



FWB190AF

new!



FWB190M



Taku Htrano, USA

Design inspired by Taku Htrano

The Mitsudomoe (mee-tsoo-DO-mo-ay) is a symbol in the Japanese Shinto Religion, representing Man, Earth, and Heaven.



"Music puts me at peace and I fall in love with it, each time I play."



Marcie Chapa, USA



FWB190LPU



Design inspired by Marcie Chapa

NEW!

**Sizes** 6 3/4" Macho & 8" Hembra  
**Material** Rubber Wood (Hevea brasiliensis Muell.-Arg.)  
**Features** MEINL Free Ride Suspension System (German patent) Unique designs Black powder coated hardware Hand selected buffalo heads 8 mm strong tuning lugs 2.5 mm rounded SSR-Rims

**Includes** Accessory pouch L-shaped tuning key Tune Up Oil  
**Colours** AF = Amber Flame LB = Leopard Burl LPU = Love, Peace & Unity M = Mitsudomoe  
**Finish** High gloss

Veronika Zobel

Leona Binz

L. Frisch

Modesto Augusto Aguero Chamorre

2.



FWB190SNT-M



FWB190CB



FWB190WH



FWB190CR-M



FWB190CAN



FWB190MS



FWB190IS

2. FREE RIDE SERIES  
(German patent)  
FWB190 WOOD BONGOS

The MEINL FWB190 Free Ride Series Wood Bongos are perfect for the ambitious beginner and for those who are looking for an affordable second set. Its professional features are outstanding in this price range.

NEW!

NEW!

new!

Sizes 6 3/4" Macho & 8" Hembra  
Material Rubber Wood  
(*Hevea brasiliensis* Muell.-Arg.)  
Features MEINL Free Ride Suspension System (German patent)  
Black powder coated hardware  
Hand selected buffalo heads  
8 mm strong tuning lugs  
2.5 mm rounded SSR-Rims

Includes Accessory pouch  
L-shaped tuning key  
Tune Up Oil  
Colours CAN = Calypso Night, high gloss  
CB = Coffee Burst, high gloss  
CR-M = Cherry Red, matte  
IS = Island Sunset, high gloss  
MS = Mega Star, high gloss  
SNT-M = Super Natural, matte  
WH = White, high gloss

3.



FWB200ARF

Chrome plated 2.5 mm rounded SSR-Rim



FWB200NT



FWB200GAB

NEW!

Sizes 6 3/4" Macho & 8" Hembra  
Material Rubber Wood  
(*Hevea brasiliensis* Muell.-Arg.)  
Features MEINL Free Ride Suspension System (patented in Germany)  
Chrome plated hardware  
Hand selected buffalo heads  
8 mm strong tuning lugs  
2.5 mm rounded SSR-Rims  
Includes Accessory pouch  
L-shaped tuning key  
Tune Up Oil  
Colours ARF = Aztec Red Fade  
GAB = Gold Amber Sunburst  
NT = Natural  
Finish High gloss

3. FREE RIDE SERIES  
(German patent)  
FWB200 WOOD BONGOS

The MEINL FWB200 Free Ride Series Wood Bongos are made from high quality components and produce a superb tone. The patented MEINL Free Ride System allows the bongo shells to resonate freely.

Bongos

# Free Ride Series Bongos

## 1. ARTIST SERIES WOOD BONGO (Luis Conte)

The MEINL Artist Series Luis Conte Signature Wood Bongo complements his congas with its black powder coated traditional style hardware and natural finish. Luis prefers the traditional style woodblock connection between the two shells.

**Sizes** 6 3/4" Macho & 8" Hembra  
**Material** Rubber Wood  
*(Hevea brasiliensis Muell.-Arg.)*  
**Features** Solid woodblock connection  
 True Skin Cow Heads  
 8 mm strong tuning lugs  
 4 mm traditional TTR-Rims  
 Black powder coated hardware  
**Includes** Accessory pouch  
 L-shaped tuning key  
 Tune Up Oil  
**Colour** NT-M = Natural  
**Finish** Matte

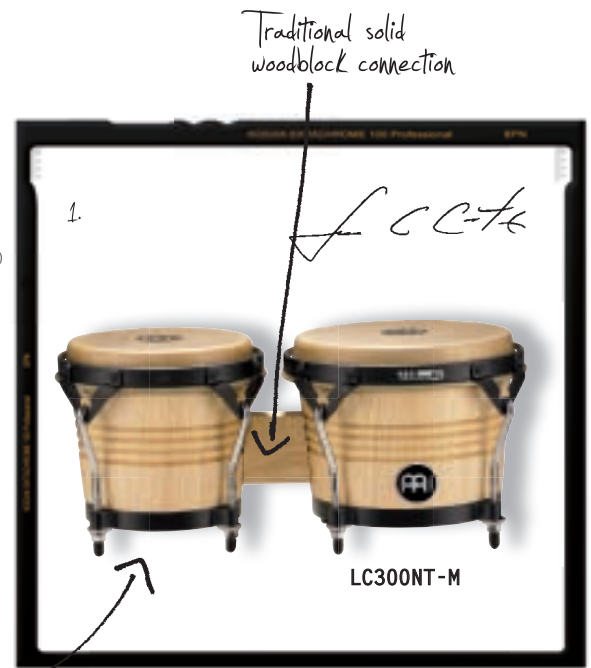

## 2. FREE RIDE SERIES (German patent) FWB300 WOOD BONGO

The MEINL FWB300 Free Ride Series Wood Bongo is equipped with traditional rims and the finest hand selected cow heads. It produces a warm yet full and voluminous sound. The patented MEINL Free Ride System allows the bongo shells to resonate freely.



Luis Conte, USA



## 3. FREE RIDE SERIES (German patent) FFB200 FIBERGLASS BONGOS

The MEINL FFB200 Fiberglass Bongos produce a compact sound with a nice spectrum of overtones. Ideal for the ambitious beginner who is looking for a dependable bongo at an affordable price.

**Sizes** 6 3/4" Macho & 8" Hembra  
**Material** Rubber Wood  
*(Hevea brasiliensis Muell.-Arg.)*  
**Features** MEINL Free Ride Suspension System (German patent)  
 Chrome plated hardware  
 True Skin Cow Heads  
 8 mm strong tuning lugs  
 4 mm traditional TTR-Rims



Chrome plated 2.5 mm rounded SSR-Rim



FFB200BSP



FFB200BKSP

**Sizes** 6 3/4" Macho & 8" Hembra  
**Material** Premium fiberglass  
**Features** MEINL Free Ride Suspension System (German patent)  
 Chrome plated hardware  
 Hand selected buffalo heads  
 8 mm strong tuning lugs  
 2.5 mm rounded SSR-Rims  
**Includes** Accessory pouch  
 L-shaped tuning key  
 Tune Up Oil  
**Colours** BKSP = Black Sparkle  
 BSP = Blue Sparkle  
 STS = Sterling Silver

Extraordinary sparkling effect

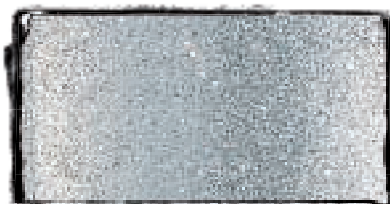

FFB200STS





FFB400CA

*Crisp and clean carbon finish*

Sizes 7" Macho & 8 1/2" Hembra  
 Material Premium fiberglass  
 Features MEINL Free Ride Suspension System (German patent)  
 Resonance Shaping Area  
 Chrome plated hardware  
 True Skin Cow Heads  
 8 mm strong tuning lugs  
 3 mm rounded SSR-Rims  
 Includes Accessory pouch  
 L-shaped tuning key  
 Tune Up Oil  
 Colour CA = Carbon finish



4. FIBERCRAFT DESIGNER SERIES BONGO (German patent)  
 The MEINL Fibercraft Designer Series Bongo comes in a dazzling look. This bongo is made from premium fiberglass for dependability and great sound characteristics.



FFB400BSP



FFB400STS



*Extraordinary sparkling effect*



FFB400BKSP

5. FREE RIDE SERIES (German patent) FFB400 FIBERGLASS BONGOS  
 The MEINL FFB400 Free Ride Series Fiberglass Bongos have a stunning sound reaching from powerful mids to sharp highs. Thanks to their fiberglass shells they are extremely durable and the perfect instrument for the working musician on the road.

6. FREE RIDE SERIES (German patent) MINI WOOD BONGOS  
 The MEINL Mini Wood Bongo is a smaller version of a full-sized bongo. It is equipped with professional features in miniature size just like the regular size standard model.

Sizes 7" Macho & 8 1/2" Hembra  
 Material Premium fiberglass  
 Features MEINL Free Ride Suspension System (patented in Germany)  
 Chrome plated hardware  
 True Skin Cow Heads  
 8 mm strong tuning lugs  
 3 mm rounded SSR-Rims  
 Resonance Shaping Area  
 Includes Accessory pouch  
 L-shaped tuning key  
 Tune Up Oil  
 Colours BKSP = Black Sparkle  
 BSP = Blue Sparkle  
 STS = Sterling Silver



*Chrome plated rounded SSR-Rim*



6.



FWB100SNT-M



FWB100TSR-M



Sizes 3 1/2" Macho & 4 1/4" Hembra  
 Material Rubber Wood (Hevea brasiliensis Muell.-Arg.)  
 Features Free Ride Suspension System (German patent)  
 True Skin Buffalo Heads  
 Rounded SSR-Rims  
 Chrome plated hardware  
 Includes Tuning key  
 Colours SNT-M = Super Natural  
 TSR-M = Tequilla Sunrise  
 Finish Matte

*Miki Wielecki, Poland*



*Christian Fehre, Germany*



*Bongos*

# Free Ride Series Wood Bongos



1. FREE RIDE SERIES  
(German patent)  
FWB400 WOOD BONGOS

The MEINL FWB400 Free Ride Series Wood Bongos are the preferred bongo model by many top percussionists. Exceptional sound qualities combined with a wide variety of colours make it the perfect bongo for the working musician.



FWB400CR

FWB400EBK



FWB400NT

FWB400GAB

Resonance Shaping Area!



Chrome plated  
3 mm rounded  
SSR-Rim



FWB400BB



FWB400ARF

**NEW!**

Sizes 7" Macho & 8 1/2" Hembra  
Material Rubber Wood  
(*Hevea brasiliensis* Muell.-Arg.)  
Features MEINL Free Ride Suspension System (German patent)  
Chrome plated hardware  
True Skin Cow Heads  
8 mm strong tuning lugs  
3 mm rounded SSR-Rims  
Resonance Shaping Area

Includes Accessory pouch  
L-shaped tuning key  
Tune Up Oil  
Colours ARF = Aztec Red Fade  
BB = Brown Burl  
CR = Cherry Red  
EBK = Ebony Black  
GAB = Gold Amber Sunburst  
NT = Natural  
Finish High gloss



Rafał Dziubiński,  
Poland



Papa Niko, Italy

Steffen, Christina and  
Lana Bergmann

Martin Schuldt





CS400AWA-M

- Sizes 7" Macho & 8 1/2" Hembra
- Material AWA-M = American White Ash (*Fraxinus americana* L.)
- Features MEINL Free Ride Suspension System (German patent)  
Chrome plated hardware  
True Skin Cow Heads  
8 mm strong tuning lugs  
3 mm rounded SSR-Rims  
Resonance Shaping Area
- Includes Accessory pouch  
L-shaped tuning key  
Tune Up Oil
- Finish Matte



MBB

- Material Heavy duty padded nylon
- Features Additional room for accessories  
Padded shoulder strap  
Carrying grip  
Padded separator



The Meinl Collection Series Wood Bongo won the MEINL Award in the Best Percussion Product category.



WB500ZFA-M

- Sizes 7" Macho & 9" Hembra
- Material American White Ash (*Fraxinus americana* L.)
- Features MEINL Free Ride Suspension System (German patent)  
Chrome plated hardware  
True Skin Cow Heads  
8 mm strong tuning lugs  
4 mm traditional TTR-Rims  
Resonance Shaping Area
- Includes Accessory pouch  
L-shaped tuning key  
Tune Up Oil
- Colours AMB = Antique Mahogany Burst, high gloss  
ZFA-M = Zebra Finished Ash, matte



NEW!



WB500AMB



Chrome plated 4 mm traditional TTR-Rim

2. FREE RIDE COLLECTION SERIES (German patent) WOOD BONGO

The MEINL Collection Series Wood Bongo is the finest bongo available today. It is made entirely by hand and exhibit unparalleled sound, charm, and workmanship.

3. PROFESSIONAL BONGO BAG

The MEINL Bongo Bag fits all common bongo models and still has enough room for some hand percussion instruments. A padded separator is included.

4. FREE RIDE SERIES (German patent) WOODCRAFT BONGOS

The MEINL Woodcraft Bongos, just as the Woodcraft Congas, stand for tradition combined with exceptional workmanship. Only the finest hand selected materials are used to produce this premium bongos which produce the authentic loud bongo slap.



Bongos

# Bongo Stands

## 1. PROFESSIONAL BONGO STAND

The MEINL Bongo Stand features a new design concept and simple functionality. The bongo is placed on a padded T-shaped tube and secured with a convenient knob screw. A stable metal clamp holds the entire unit securely in place.

- Material** Chrome plated steel
- Features** Padded T-shaped tube  
Fully height- and angle adjustable  
Double braced tripod legs  
Fits all common bongos
- Includes** Allen wrench  
Memory locks

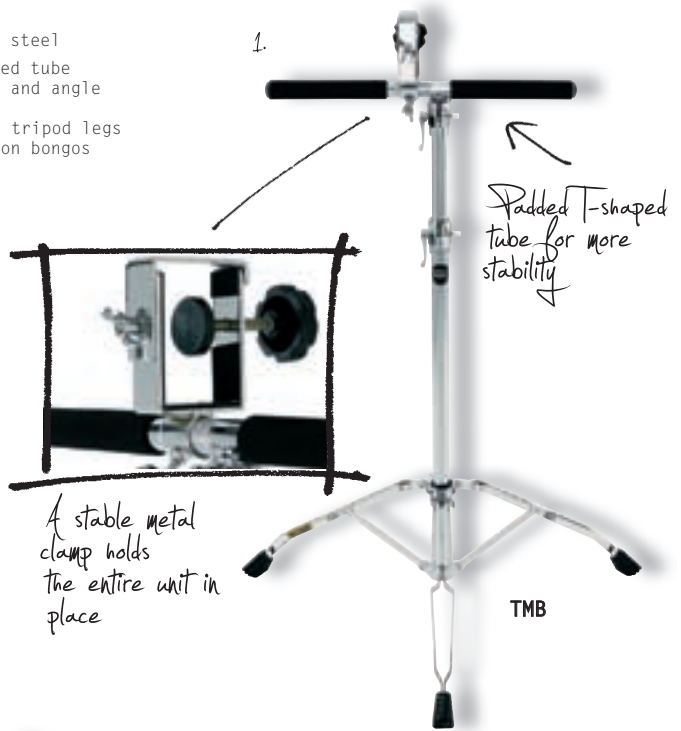

## 2. BONGO STANDS (patented)

The MEINL Headliner® Series Bongo Stands combine easy handling and functionality with reliability and sturdy construction. A newly designed bracket enables extremely quick and easy mounting, yet holds the entire bongo securely in place.

## 3. PROFESSIONAL BONGO STAND FOR SEATED PLAYERS

This version of MEINL's Professional Bongo Stand has all the features of the regular model. However, it can be placed low enough to be comfortably played sitting down in the traditional position.



- Material** Chrome plated steel
- Features** Seated playing position possible  
Padded T-shaped tube  
Fully height- and angle adjustable  
Double braced tripod legs  
Fits all common bongos
- Includes** Allen wrench  
Memory lock

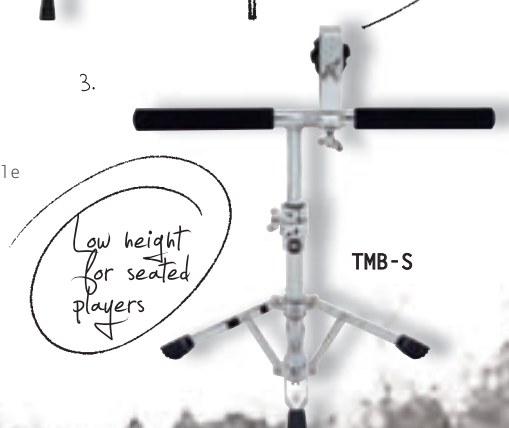

\* Germany, China, United States

José Angel Barberena Riera

Sabrina Giel



# Headliner® Series Dancing Percussion

The MEINL Headliner® Series Dancing Percussion are the perfect instruments for educational or street percussion. They are made from high quality materials and produce great sounds. A great gift idea as well.

1. FIBERGLASS DANCING CONGA
2. FIBERGLASS DANCING DJEMBE
3. FIBERGLASS FAMILY DRUMS
4. FIBERGLASS MINI DANCING DJEMBE

1.



HC301MC

2.



HDJ400MC

*Eye catching multi colour finish*

Size 8 1/2"  
24" tall  
Material Premium fiberglass  
Features 7 mm strong tuning lugs  
2.2 mm rounded rim  
Black powder coated hardware  
Includes Nylon strap  
Tuning key  
Colour MC = Multi colour

Size 12"  
22 3/4" tall  
Material Premium fiberglass  
Features 7 mm strong tuning lugs  
2.2 mm rounded rim  
Black powder coated hardware  
Includes Nylon strap  
Tuning key  
Colour MC = Multi colour

3.

Sizes HFDD1MC = 8 3/4", tall 13 1/2"  
HFDD2MC = 8", tall 11 1/4"  
HFDD3MC = 7 1/2", tall 9 3/4"  
Material Premium fiberglass  
Features 8 mm strong tuning lugs  
Traditional rim  
Black powder coated hardware  
Includes Nylon strap  
Tuning key  
Colour MC = Multi colour



HFDD1MC

HFDD2MC

HFDD3MC

4.



HDJ200MC

Sizes 8", tall 11 1/3"  
Material Premium fiberglass  
Features Traditional rim  
Black powder coated hardware  
Floatune Tuning System  
Includes Nylon strap  
Tuning key  
Colour MC = Multi colour



Amel Serra  
Belgium

Jorge E. Porras

Kristyna  
Barchankova

Jochen  
Weigand

Janika  
Herz

R. Schult



*Bongos*

BONGO STANDS



Petra Öhrlein, Germany



Mario "Mafisto"  
Zöller, Germany

Carina Strenz,  
Germany

# Djembes

# Headliner® Series Rope Tuned Djembes

## CONGO SERIES

The MEINL Headliner® Series Rope Tuned Djembes are carved from one solid piece of plantation grown Mahogany Wood and feature the traditional Mali Weave tuning system.

Hand selected  
goat head



HDJ1-XL

Sizes	Tall
M = 10"	20"
L = 12"	24"
XL = 13"	25"

PP Rope	Thickness	Runners
M	4 mm	18
L	5 mm	20
XL	6 mm	24

Materials Mahogany Wood

Features Carved from one solid piece of plantation grown Mahogany Wood  
Hand selected goat heads  
Pre-stretched PP nylon ropes  
Hand carved shells  
Ornamental carving

Colour Dark Brown

Carved from one solid piece of plantation grown Mahogany Wood

Hand carved shells



HDJ1-L



HDJ1-M





**TRIBAL SERIES**

The black MEINL Headliner® Series Rope Tuned Djembes are painted with a tribal design and feature the traditional Mali Weave tuning system. The black body is made out of one solid piece of Mahogany Wood.

- Materials Mahogany Wood
- Features Carved from one solid piece of plantation grown Mahogany Wood  
Hand selected goat heads  
Pre-stretched PP nylon ropes  
Hand carved shells
- Colour Black with tribal painting

4 mm Pre-stretched PP nylon ropes



HDJ2-M



HDJ2-L



HDJ2-XL

Tribal painting



Ismaila M'Baye, Italy



# Original African Style Rope Tuned Wood Djembes

Bundle  
with bag

The MEINL Original African Style Rope Tuned Wood Djembes are carved from one solid piece of plantation grown Mahogany Wood. These high quality instruments are crafted with great attention to detail and provide an outstanding, full-volume sound. We offer these drums in three different series: The Earth Rhythm Series features a carved design in black and brown. Its earthy pattern is evocative of ploughed fields and stalks of grain. The Moon Rhythm Series features a carved design in a dark mystic finish. The Water Rhythm Series features a carved design evocative of ocean waves, and all djembes come bundled with the Professional MEINL Djembe Bag.

SIZES	DIAMETER	TALL
M = 10"	9 1/4"-10 1/4"	20"
L = 12"	10 3/4"-12 1/4"	24"
XL = 13"	12 3/4"-13 3/4"	25"

HTP ROPE	THICKNESS	RUNNERS
M	4 mm	25
L	4 mm	35
XL	5 mm	35

- Material** Mahogany Wood
- Features** Carved from one solid piece of plantation grown Mahogany Wood  
Hand selected goat heads  
Pre-stretched HTP nylon ropes  
Hand carved shells  
Ornamental carving
- Includes** Professional Djembe Bag made out of heavy duty padded nylon
- Colour** ADJ2 = Brown  
ADJ3 = Brown/Black  
ADJ4 = Black



Earth Rhythm Series

ADJ3-XL+BAG  
bundle with MDJB-M

Water Rhythm Series

ADJ2-XL+BAG  
bundle with MDJB-M

Moon Rhythm Series

ADJ4-XL+BAG  
bundle with MDJB-M

Hannes Auerochs

Comes with bag



**ADJ4-L+BAG**  
bundle with MDJB-M

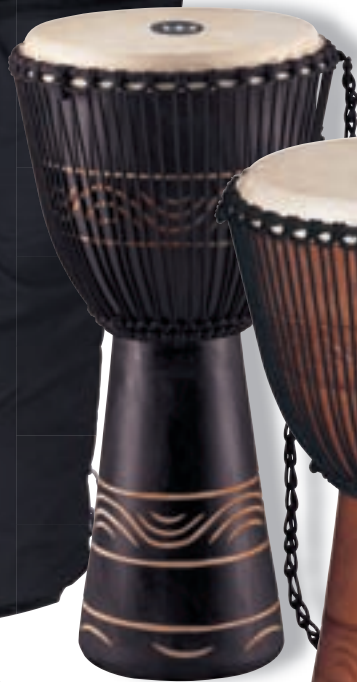

**ADJ2-L+BAG**  
bundle with MDJB-M



**ADJ3-L+BAG**  
bundle with MDJB-M

Hand selected  
goat head

Pre-stretched  
high quality  
notion rope

Carved from one solid  
piece of plantation grown  
Mahogany Wood



**ADJ4-M+BAG**  
bundle with MDJB-S



**ADJ3-M+BAG**  
bundle with MDJB-S



**ADJ2-M+BAG**  
bundle with MDJB-S



Heike Sämman-Held

*Djembes*

ORIGINAL AFRICAN STYLE ROPE TUNED WOOD DJEMBES



Prince Alongo, Togo

Outstanding carving of our **ROAD J3-XXL**  
Rama Sita Deluxe Djembe

# Professional African Style Djembes

Size L = 12", 24" tall  
30 runners 5 mm HTP nylon rope

Material Mahogany Wood

Features Carved from one solid piece of plantation grown Mahogany Wood  
Hand selected goat heads  
Pre-stretched HTP nylon rope  
1) Traditional style hewn  
2) Special "village" carving

Colour Brown



## 1. PROFESSIONAL AFRICAN DJEMBE

The MEINL Professional African Djembe is expertly hewn from a solid piece of Mahogany Wood, and fitted with a hand selected goatskin head. We use the traditional Mali Weave tuning system with high quality HTP rope. Thirty vertical runners keep the head in tune, properly balanced, and looking proud.

## 2. PROFESSIONAL AFRICAN DJEMBE

The MEINL Professional African Djembe with "village" carving is expertly formed from solid piece of Mahogany Wood, and decoratively carved with a village scene. The hand selected goatskin head is secured with the traditional Mali-weave tuning system. Thirty vertical runners of high quality HTP rope assure proper tuning, and keep your drum looking great.

## 3. RAMA SITA DELUXE DJEMBE

Our Deluxe Djembe is hand carved from a solid plantation grown Mahogany log, and exquisitely carved with figures from the Ramayama, the epic Hindu legend and love story of Rama and Sita. Each djembe is a work of art. We make sure it sounds as good as it looks with top quality hand-selected goat skin heads, and the best pre-stretched HTP rope. We cherish our Deluxe Djembes as a collectors item, and so will you.



Special "village" carving

PROADJ2-L

Ornamental carving

PROADJ1-L

**NEW!**



Carved from one solid piece of plantation grown Mahogany Wood

PROADJ3-XXL

Size XXL = 14"  
26" tall

Material Mahogany Wood

Features Carved from one solid piece of plantation grown Mahogany Wood  
Hand selected goat heads  
Pre-stretched HTP nylon rope  
Deluxe carving

Colour Brown

SIZES	DIAMETER	TALL
L = 12"	10 3/4"-12 1/4"	24"
XXL = 14"	13 3/4"-15 1/4"	26"

HTP ROPE	THICKNESS	RUNNERS
L	4 mm	35
XXL	5 mm	40

*Djembes*

PROFESSIONAL AFRICAN STYLE DJEMBES

# Bougarabou & Wood Djembes

## 1. AFRICAN BOUGARABOU

The MEINL Bougarabou is proudly made in the tradition of the Jola people of southern Senegal. The classic bougarabou features an elongated goblet-shaped body carved from Mahogany Wood. A bougarabou can be played with traditional conga or djembe techniques, and makes a rich complement within drum ensembles.

## 2. ROPE TUNED WOOD DJEMBES

The MEINL Rope Tuned Wood Djembes are crafted with great attention to detail. They feature the traditional rope tuning system. A great sounding drum at an affordable price.

1.

Size	L = 12", 24" tall 22 runners, 5 mm HTP nylon rope
Material	Mahogany Wood
Features	Carved from one solid piece of plantation grown Mahogany Wood Hand selected cow head Pre-stretched HTP nylon rope Intricate carving
Colour	Brown

ABGB-L

Hand selected cow head

2.



Traditional rope tuning system

Size	12" 24 1/4" tall
Material	Rubber Wood ( <i>Hevea brasiliensis</i> Muell.-Arg.)
Features	True Skin Calf Heads Traditional rope tuning system
Colours	AB-M = African Brown NT-M = Natural
Finish	Matte

DJWR3NT-M

DJWR3AB-M

Rubber ringed bottom for more stability and protection



# Headliner® Series Djembes

!!! All djembes are equipped with six tuning lugs for a good tuning system

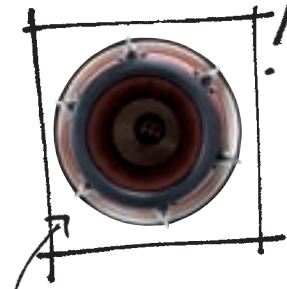

HDJ600WRB



HDJ600VSB



HDJ600NT

## 1. HEADLINER® SERIES WOOD DJEMBES

The MEINL Headliner® Series Djembes have it all! Equipped with hand selected goat heads, they produce the classic djembe sounds reaching from fat basses to rich open tones and cutting slaps.

## 2. HEADLINER® DESIGNER SERIES DJEMBES

The MEINL Headliner® Designer Series Djembes are a great all-around lug tuned djembes, perfect for drum circles and spontaneous jam sessions.

Size	12" 23 1/2" tall
Material	Rubber Wood ( <i>Hevea brasiliensis</i> Muell.-Arg.)
Features	8 mm strong tuning lugs 2 mm rounded rims Original MEINL style tuning brackets Black powder coated hardware Hand selected goat heads
Includes	Tuning key
Colours	NT = Natural VSB = Vintage Sunburst WRB = Wine Red Burst
Finish	High gloss

**NEW!**

Black powder coated 2 mm rounded rim

**NEW!**

Army Issue →

Size	12" 23 1/2" tall
Material	Cloth-covered Rubber Wood ( <i>Hevea brasiliensis</i> Muell.-Arg.)
Features	8 mm strong tuning lugs 2 mm rounded rims Original MEINL style tuning brackets Black powder coated hardware Hand selected goat heads
Includes	Tuning key
Colours	AI = Army Issue, matte KF = Kilt Finish, high gloss MDC = Midnight Desert Camo, high gloss



HDJ600AI



HDJ600KF



HDJ600MDC

*Djembes*

# Floatune Series Djembes

Repositioned tuning lugs offer perfect playing comfort



**Size** 12 3/4"  
25 1/4" tall

**Material** Rubber Wood  
(*Hevea brasiliensis* Muell.-Arg.)

**Features** True Skin Goat Heads  
8 mm strong tuning lugs  
3 mm rounded SSR-Rims  
Easy tuning and comfortable change of heads  
Rubber pads and lug placement offer perfect playing comfort  
Floatune Tuning System  
Chrome plated hardware

**Includes** Accessory pouch  
L-shaped tuning key  
Tune Up Oil

**Colours** AB-M = African Brown, matte  
GAB-M = Gold Amber Sunburst, matte  
NT = Natural, high gloss



Special rubber pads for perfect playing comfort

## 1. FLOATUNE SERIES 12 3/4" WOOD DJEMBES

The 12 3/4" MEINL Floatune Djembe is modeled after the West African originals. Deep, round-sounding bass notes complimented by crisp tones and slaps are produced by this drum.

## 2. FLOATUNE SERIES 12" WOOD DJEMBES

The proportions of this drum provide higher, brighter tones and slaps, while retaining a clear, full bass note. This model is a bit more compact and lighter in weight.

## 3. FLOATUNE SERIES WOOD DJEMBE

The MEINL Floatune Wood Djembe is made from finest American White Ash (*Fraxinus americana* L.) which produces an excellent full-volume djembe sound.

## 4. FLOATUNE SERIES FIBERGLASS DJEMBES

The MEINL Floatune Series Fiberglass Djembes are truly a sound alternative. Fiberglass has enormous strength and can produce slaps of outstanding clarity and immensely powerful bass tones.

2.



**Size** 12"  
24 1/4" tall

**Material** Rubber Wood  
(*Hevea brasiliensis* Muell.-Arg.)

**Features** True Skin Goat Heads  
8 mm strong tuning lugs  
3 mm rounded SSR-Rims  
Easy tuning and comfortable change of heads  
Rubber pads and lug placement offer perfect playing comfort  
Floatune Tuning System  
Chrome plated hardware

**Includes** Accessory pouch  
L-shaped tuning key  
Tune Up Oil

**Colours** AB-M = African Brown, matte  
GAB-M = Gold Amber Sunburst, matte  
NT = Natural, high gloss



3.



Chrome plated 3 mm rounded SSR-Rim



American White Ash

Floatune Tuning System



DJW3ZFA-M

- Size 12"  
24 1/4" tall
- Material American White Ash  
(*Fraxinus americana* L.)
- Features True Skin Goat Head  
8 mm strong tuning lugs  
3 mm rounded SSR-Rim  
Easy tuning and comfortable change of heads  
Rubber pads and relocated lugs offer perfect playing comfort  
Floatune Tuning System  
Chrome plated Hardware
- Includes Accessory pouch  
L-shaped tuning key  
Tune Up Oil
- Colour ZFA-M = Zebra Finished Ash
- Finish Matte

The head can be tuned very simply



DJF3RSP

DJF3BSP



Extraordinary sparkling effect

- Size 12"  
24 1/4" tall
- Material Premium fiberglass
- Features True Skin Goat Heads  
8 mm strong tuning lugs  
3 mm rounded SSR-Rims  
Easy tuning and comfortable change of heads  
Rubber pads and lug placement offer perfect playing comfort  
Floatune Tuning System  
Chrome plated hardware
- Includes Accessory pouch  
L-shaped tuning key  
Tune Up Oil
- Colours BSP = Blue Sparkle  
RSP = Red Sparkle

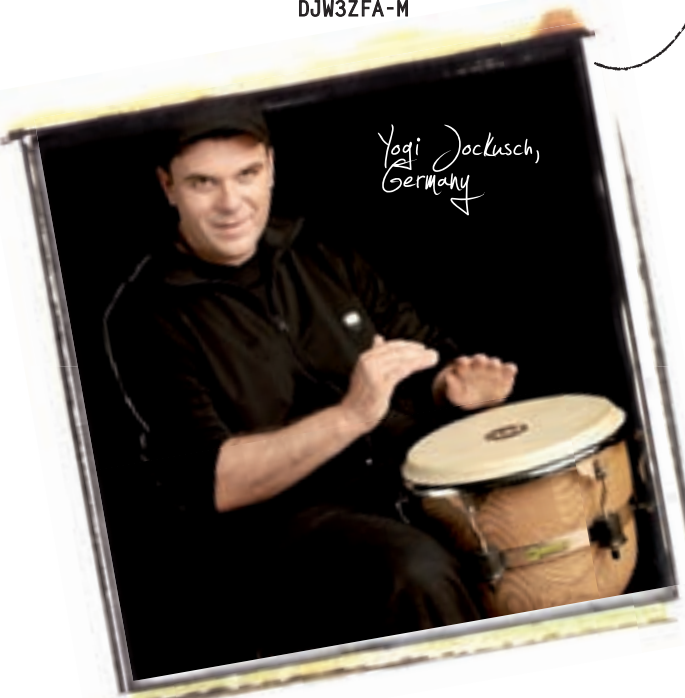

Yogi Jockusch, Germany

Bianca Schäfer

Rene Gonzalez and friend

Kathrin Pilz



# Stands & Bags

## 1. STEELY II DJEMBE STAND (patented)

The Steely II Djembe stand features all of the same designs as the Steely II Conga stands. It can be adjusted to accommodate various djembe sizes using three spacers and is fully height adjustable. It is perfect for drum circles and other street percussion activities.

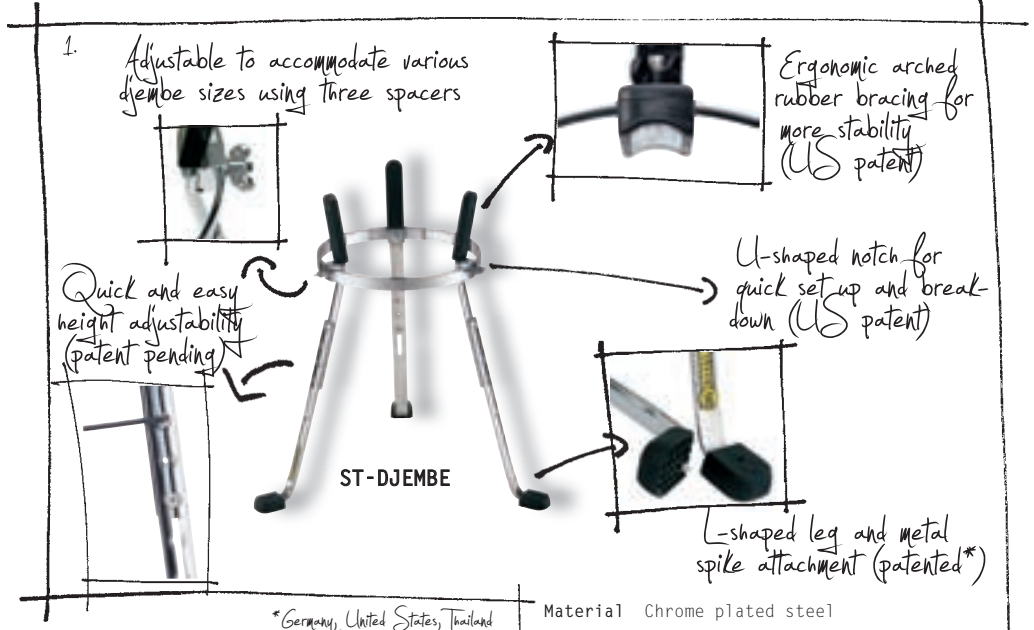

\*Germany, United States, Thailand

<b>Material</b>	Chrome plated steel
<b>Features</b>	Metal spike attached to each leg L-shaped legs (patented) U-shaped notch for quick set up and breakdown (US patent) Notches for quick height adjustability (patent pending) Adapts to different djembe sizes
<b>Includes</b>	Allen wrench 3 spacers

## 2. PROFESSIONAL DJEMBE STAND

The MEINL Djembe Stand was designed to firmly hold any djembe in the traditional playing position. A nylon strap is secured around the drum and two rubber padded u-shaped hooks slide into the bottom of the shell. It can be angled, and is fully height adjustable.

2. Length adjustable for various djembe sizes

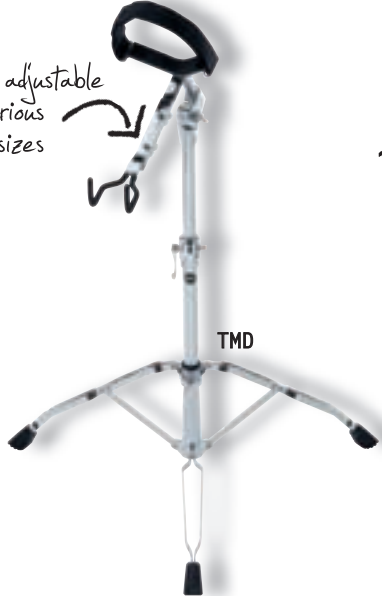

## 3. KESSING

The Kessing is a traditional djembe accessory that provides a dry rattling accompaniment to the drum. It slides securely into the webbing and is removable.

3.



KES-01

Size Medium  
Material Aluminum

<b>Material</b>	Chrome plated steel
<b>Features</b>	Rubber padded hooks Fully height- and angle adjustable Double braced tripod legs
<b>Includes</b>	Allen wrench Memory lock

4.

Adjustable straps



MDJS1

<b>Material</b>	Cloth-covered nylon
<b>Features</b>	Quick change hook Adjustable straps Quick-release buckles
<b>Colour</b>	Multi colour

Zarubin Andrey and friend

Christin Bartels





5.



Sizes	M = 10" L = 12" XL = 13"
Material	Heavy duty padded nylon
Colour	Black

### 5. PROFESSIONAL DJEMBE CAPS

The MEINL Professional Djembe Caps protect your drum with a heavy duty reinforced top and an extra-long skirt with an elastic waist band.

### 6. PROFESSIONAL DJEMBE BAGS

The MEINL Djembe Bags come in three sizes, medium, large, and small to fit all common djembe models. Additional features include padded backpack straps and an external pocket for accessories.



Sizes	Small (up to 10") Medium (up to 12") Large (up to 13 1/2")
Material	Heavy duty padded nylon
Features	External pocket Padded backpack straps Carrying grip

### 7. DELUXE DJEMBE BAGS

The MEINL Deluxe Djembe Bags feature an additional layer of synthetic fur, which removes surface moisture and provides additional protection. They come in medium and large sizes enabling them to fit all common djembe models. Additional features include padded backpack straps and an external pocket for accessories.



Sizes	Medium (up to 12") Large (up to 13 1/2")
Materials	Heavy duty padded nylon Synthetic fur
Features	External pocket Padded backpack straps Carrying grip



Lucia Furich,  
Germany

*Stands & Bags*



Roland Peil, Germany

Amadito Valdés, Cuba

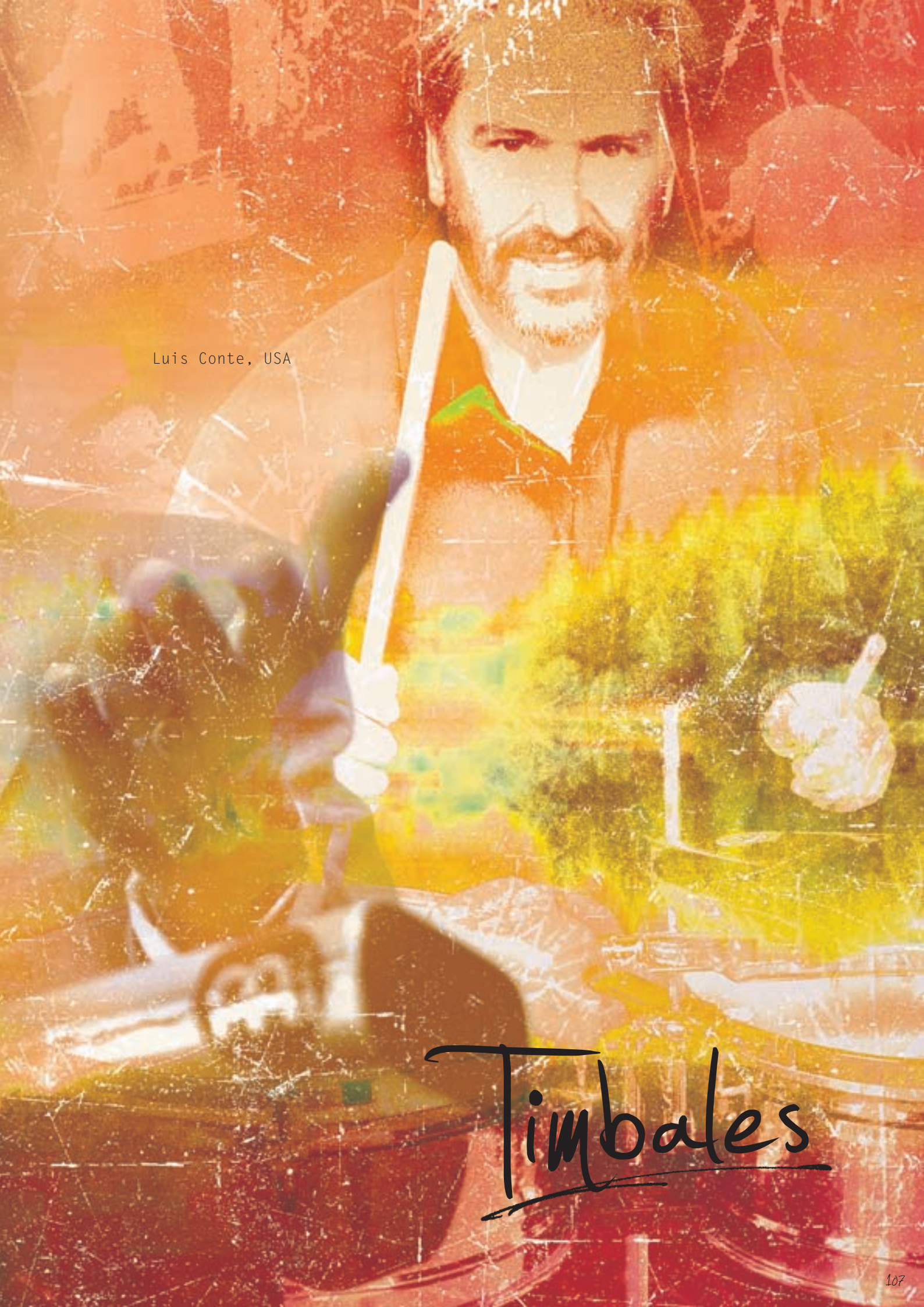
A man with a beard and mustache, wearing a white long-sleeved shirt and a red apron, is smiling and looking towards the camera. He is in a kitchen, with his hands near a wooden cutting board. The background is a warm, orange-toned wall with a patterned wallpaper. The overall image has a textured, slightly distressed appearance with some scratches and dust marks.

Luis Conte, USA

# Timbales

# Headliner® Series Timbales

## 1. HEADLINER® SERIES (US patent)

The MEINL Headliner® Series Timbales come in 13" and 14" sizes, are made from chrome plated steel and come with a heavy-duty, height adjustable tilting stand. They provide the classic timbale sound and are the perfect introduction to the joy and passion of timbale playing at an affordable price.

## 2. DRUMMER TIMBALES MINI TIMBALE (US patent)

The MEINL Drummer and Mini Timbales provide the characteristic timbale sounds and projection that cuts through any band setting. It is a perfect addition to any percussion or drum set configuration.

## 3. ARTIST SERIES (Taku Hirano) SIGNATURE HAND-BALE (DGBM/German Register Utility Model)

Taku Hirano wanted to add timbale accents and fills while playing on congas and multi-percussion set-ups, without needing sticks. His signature Hand-Bale now makes that possible! The retaining rim of the Hand-Bale is uniquely made with one half traditionally shaped, while the other half of the rim is recessed below the shell. This opens the timbale to bongo style hand techniques that easily produce an unmistakably crisp timbale sound. Stick techniques are possible on the traditionally rimmed portion of the drum. As Taku himself put it, *"The instrument sounds great using bongo technique so that if you use one- or two-finger hits on the edge with the same force that you would play mounted bongos, you are able to effectively recreate the quintessential timbale rim stroke. No sticks? No problem! Cracking timbale fills at your fingertips ..."*



Sizes	13" & 14"
Material	Steel
Feature	Logo applied from underneath the head (US patent)
Includes	Height adjustable tilting double braced tripod stand Tuning key Wrench Cowbell holder
Finish	Chrome

2.

MIT810CH

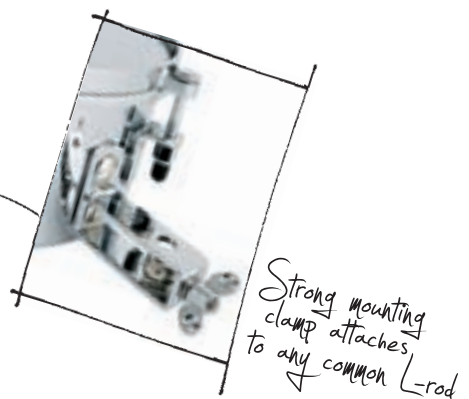

MDT13CH



Sizes	13" drummer timbale 8" & 10" mini timbale
Material	Steel
Features	Strong mounting clamp Logo applied from underneath the head (US patent)
Includes	L-shaped tuning key Tune Up Oil
Finish	Chrome



Taku Hirano, USA

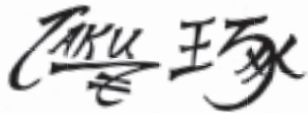

Inventor →



Special designed rim

- Size 13"
- Material Steel
- Features Special designed rim  
Strong mounting clamp  
Logo applied from underneath the head (US patent)
- Includes L-shaped tuning key  
Tune Up Oil
- Colour BK = Black
- Finish High gloss

3. No sticks? No problem! Cracking timbale fills at your fingertips

**NEW!**



MHT13BK

(DGBM/German Register Utility Model)

The three arm basket holds the Hand-Bale securely!

- Material Chrome plated steel
- Features Quick set up  
Rubber-tipped three arm basket  
Easy handling  
Double braced tripod stand

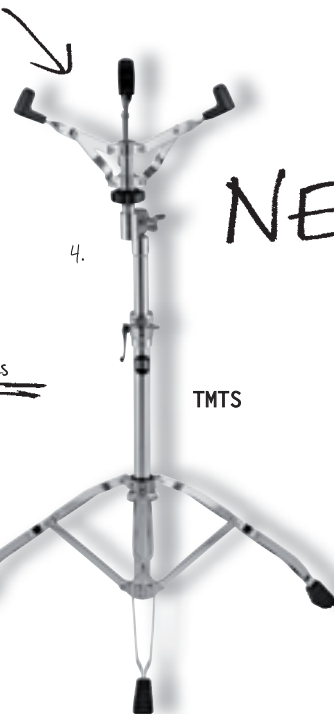

**NEW!**

TMTS

This stand also fits for our caixas

4. HAND-BALE STAND

Our new Hand-Bale Stand is double-bracketed and fully adjustable. The Hand-Bale is held securely in a rubber-tipped three arm basket.

5. ARTIST SERIES (DAVE MACKINTOSH) ATTACK TIMBALES

DragonForce drummer Dave Mackintosh wanted a distinctive sound for his Signature Attack Timbales. Here's what we did: We made a pair of 8" diameter timbale shells with a depth of 9" and 11" respectively. This creates a distinctive and tightly matched interval "dialogue". The Dave Mackintosh's Signature Attack Timbales are easily mounted on a rack, drum set, or any standard L-rod.

Dave Mackintosh, UK



**NEW!**



MDT88BN

5.

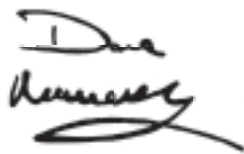

- Sizes 8" x 9", 8" x 11"
- Material Steel
- Features Strong mounting clamp  
Logo applied from underneath the head (US patent)
- Includes L-shaped tuning key  
Tune Up Oil
- Colour BN = Black Nickel

Timbales

# Marathon® Series Timbales

MEINL Marathon® Series Timbales are professionally equipped yet are offered at an affordable price. They are perfect for the working percussionist or to be included in a drum setup.



- Sizes 14" & 15"
- Material Steel
- Features Two worked in flanges  
Heavy duty style brackets  
Logo applied from underneath the head (US patent)
- Includes Adjustable cowbell holder  
Height adjustable tilting double braced tripod stand  
Accessory pouch  
L-shaped tuning key  
Tune Up Oil
- Finishes B = Brass  
BN = Black nickel  
CH = Chrome



# Floatune Series Timbales



*Amadito Valdès*



*Amadito Valdès, Cuba*

- Sizes 14" & 15"
- Material Black powder coated steel
- Features Two worked in flanges  
Floatune Tuning System  
Logo applied from underneath the head (US patent)
- Includes Adjustable cowbell holder  
Height adjustable tilting double braced tripod stand  
Accessory pouch  
L-shaped tuning key  
Tune Up Oil

## 1. ARTIST SERIES (Amadito Valdès) (US patent)

The MEINL Artist Series Amadito Valdès Timbales - a tribute to one of the greatest timbaleros ever.

## 2. FLOATUNE SERIES (US patent)

The MEINL Floatune Tuning System used on these timbales works without having to drill into the shell. The result is a voluminous timbale sound with a crisp and warm response, cutting rim shots and a great Cascara sound.



- Sizes 13" & 14"
- Material Black powder coated steel
- Features Two worked in flanges  
Floatune Tuning System  
Logo applied from underneath the head (US patent)
- Includes Adjustable cowbell holder  
Height adjustable tilting double braced tripod stand  
Accessory pouch  
L-shaped tuning key  
Tune Up Oil

*Timbales*

# Artist Series Timbales

ARTIST SERIES TIMBALES  
(Luis Conte) (US patent)

It is with the greatest appreciation and the deepest respect that we honour our friend Luis and his life's work with his MEINL Artist Series Luis Conte Signature Timbales. Perfection in even the smallest details has been achieved in this outstanding instrument. All of the specifications Luis required for his instrument have been consequently realized.



Luis Conte, USA

Logo applied from underneath the head to prevent from wearing off (US patent)



Counter sunk bolt head and bracket cast from special alloy

LC1BRASS



Extensively hammered shell



LC1STS

Thoughtfully arranged lugs enable an easy way to play the Castara



The Meinl Artist Series Timbales (Luis Conte) won the MIPA Award in the "Best Percussion Product" category.



L. Conte

- Sizes 14" & 15"
- Materials Solid brass or stainless steel
- Features Extensively hammered shells  
Two worked in flanges  
Cuban style flared out bottom edge  
Brackets cast from special brass alloy  
Logo applied from underneath the head (US patent)
- Includes Adjustable cowbell holder  
Height adjustable tilting double braced tripod stand  
Accessory pouch  
L-shaped tuning key  
Tune Up Oil

# Professional Series Timbales

1.

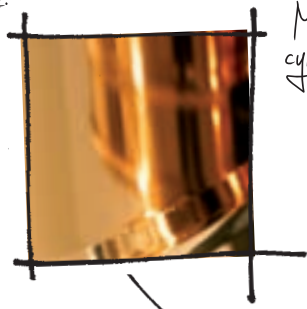

Made from German B8 cymbal bronze

Logo applied from underneath the head to prevent from wearing off (US patent)

Counter sunk bolt head and bracket cast from special alloy



Cuban style flared out bottom edge



Thoughtfully arranged lugs enable an easy way to play the Cascara



- Sizes 14" & 15"
- Material German B8 cymbal bronze
- Features Two worked in flanges  
Cuban style flared out bottom edge  
Brackets cast from special brass alloy  
Logo applied from underneath the head (US patent)
- Includes Adjustable cowbell holder  
Height adjustable tilting double braced tripod stand  
Accessory pouch  
L-shaped tuning key  
Tune Up Oil

BT1415



*Roland Meinl*

2.

- Sizes 14" & 15"
- Material Heavy duty padded nylon
- Features External pocket for stand and cowbell  
Padded shoulder strap  
Carrying grip  
Padded separator



MTB

## 1. PROFESSIONAL SERIES (US patent)

The Roland Meinl Professional Series Timbales are made from finest German B8 cymbal bronze. They produce a fantastic warm sound with cutting rim shots and enhanced Cascara playing.

## 2. PROFESSIONAL TIMBALES BAG

The MEINL Timbales Bag has two internal compartments (padded separator included) to fit both timbale drums (up to 15") and an outside pocket to fit the stand, cowbells, and sticks.

*Timbales*

# Sticks & Beaters

## 1. TAMBORIM STICKS

The MEINL Tamborim Sticks have three balanced, flexible plastic rods in a handy size.

1.

TBRS-R

TBRS-BK

Material Plastic  
Colours BK = Black  
R = Red

## 2. SAMBA STICKS

MEINL offers a wide assortment of Samba Sticks for Tamborims, Repiniques, and other Samba instruments in order to achieve their authentic sounds.

2.

SST1-L

SST1-R

SST1-S

Material Plastic  
Sizes SST1-S = Stick, short version  
SST1-R = Stick, regular version  
SST1-L = Stick, long version  
SST3-S = Triple stick, short version  
SST3 = Triple stick  
SST7 = Sevenfold stick

## 3. TIMBALE STICKS

The MEINL Timbale Sticks are made out of the finest hand-selected Hickory Wood and are available in four different sizes.

## 4. TIPPERS

The MEINL Bodhran Tippers come in five different styles, each with its own characteristic. They range from thin and light, to thick and full bodied. A special tipper with leather whips was designed by Thórralf Schuh.

SST3-S

SST3

SST7

## 5. SAMBA BEATERS

MEINL offers a wide assortment of Samba Beaters for Surdos and Repiniques in order to achieve their authentic sounds. All beaters are made from high quality materials to assure comfortable playing.

3.

TS5/16

TS3/8

TS7/16

TS1/2

Sizes 5/16"x15", 3/8"x15",  
7/16"x16 3/4", 1/2"x16 3/4"  
Material Hickory Wood

## 6. COWBELL BEATERS

MEINL offers a regular and professional cowbell beater for more sound options.

## 7. TALKING DRUM BEATERS

The curved playing end of the MEINL Talking Drum Beaters enables ideal positioning to strike the drum head, held near the player's body.

FDT2

FDT4

FDT1

FDT3

FDT5

Material Ash Wood  
Colour AB = African Brown

Thórralf Schuh



Inventor

5.



SB1 SB2 SB3 SB4 SB5 SB6



SB2-D SB3-D

SB1 = 15" long, aluminum stick with 2" felt beater  
 SB2 = 16" long, wood stick with 2" felt beater  
 SB2-D = 16" long, wood stick with two 2" felt beater  
 SB3 = 16" long, wood stick with 2 1/2" felt beater

SB3-D = 16" long, wood stick with two 2 1/2" felt beater  
 SB4 = 16" long, wood stick with 2" leather beater  
 SB5 = 16" long, wood stick with 3" bushy felt beater  
 SB6 = 16" long, wood stick

6.

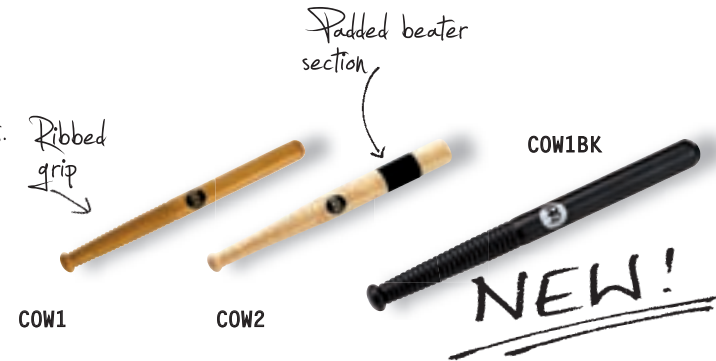

COW1 COW2 COW1BK

Material Rubber Wood (*Hevea brasiliensis* Muell.-Arg.)  
 Features Ribbed grip  
 Padded beater section

Wouter de Goovert, Netherlands



Ryan Kirschman

7.

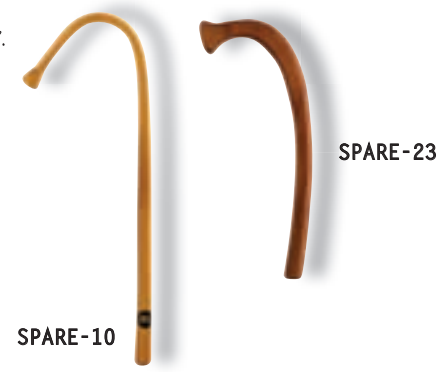

SPARE-10

SPARE-23

SPARE-10 = Rattan  
 SPARE-23 = Mahogany Wood

Marina

Klagne Papa

*Sticks*

# Gear

## 1. DESIGNER STICK BAGS

The MEINL Designer Stick Bags are available in four different finishes. These bags offer four spacious sections for drumsticks and a separate compartment for drum accessories.

Spacious stick compartments for quick access

MSB-1-C3

Shoulder strap

1.



Spacious stick compartments for quick access

## 2. DELUXE STICK BAG

The MEINL Deluxe Stick Bag offers some special features: spacious sections for drumsticks featured with zippered clear window pockets and two external pockets for extra gear.

## 3. DRUMMER GLOVES

Meinl Drummer Gloves protect your hands from blisters and prevent the sticks from slipping, yet provide a natural feel.

**Material** Heavy duty padded nylon  
**Features** External pockets  
 Shoulder straps  
 Extension straps  
**Colours** Black  
 Earth Camouflage  
 Leopard  
 Original Camouflage  
 Urban Camouflage

3.



MDGFL

MDG

**Sizes** M, L, XL

**Material** Breathable fabrics and leather

**Features** Padded areas provide more durability

MDGFL: Finger-less Gloves

**Colour** Black

## 4. COMBO BAGS

An exceptional combination of a MEINL 22" Cymbal Bag and a MEINL Stick Bag. They are joined together by a zipper on the back. Cymbals and sticks are always ready at hand.

2.



MDLXSB

**Material** Padded synthetic leather  
**Features** External pockets  
 Shoulder straps  
 Elastic cord attachments  
**Colour** Black



Cymbals and sticks are always ready at hand.

4.



MCB22/MSB

MCB22/MSB-C1

**Size** 22"

**Materials** Bag: Heavy duty padded nylon

**Features** External compartment  
 Padded dividing pads  
 Padded shoulder strap  
 Carrying grip

**Colours** Black  
 Original Camouflage

Roel Calister,  
Netherlands



# Candela Percussion Cymbals

The MEINL Candela Series of Percussion Cymbals have been designed to meet the specific requirements of today's percussionists. They are extremely thin cymbals which produce soft, exotic tones, are tonally matched and respond even at lower dynamics.



Sizes 14"  
16"  
Material B20 Bronze  
Features Hand-hammered  
Brilliant finish  
Fast response and attack  
Quick decay

1. Hand-hammered

Fast response and attack

## 1. PERCUSSION CRASHES

The crashes are thin, tonally matched cymbals which can be played by hand or hit with a stick. They respond fast and decay quickly.

## 2. PERCUSSION SPLASH

The percussion splash is an extremely thin, quick sounding cymbal - perfect for fast percussive accents.

## 3. PERCUSSION JINGLE BELL

A great cymbal with an exotic sound. Six pairs of jingles attached to this cymbal produce a rattling effect.

## 4. TIMBALES CRASH/RIDE

It's the perfect cymbal for timbale playing. It has a loud, penetrating bell and a full, warm crash sound.

## 5. PERCUSSION HIHAT

A specially designed hihat just for cajon players. Can be played by hand or with lighter sticks. The top is extremely thin for a fast, controlled response. Recommended for use with the MEINL Low Hat.

## 6. LOW HAT

The Meinl Low Hat has been designed with a special low height, made just for cajon players. It is recommended for use with the Meinl Candela 10" Percussion Hihat.

2.



CA10S

Brilliant finish

Quick response when hit by a hand!

Size 10"  
Material B20 Bronze  
Features Hand-hammered  
Brilliant finish  
Fast response and attack  
Quick decay

3.



CA14PJB

Built in jingles

Made from B8 Bronze

Size 14"  
Material B8 Bronze  
Features Precisely hammered  
Built in jingles

Cutting bell sound and great crash sound

5.



CA10PH

NEW!

Size 10"  
Material B20 Bronze  
Feature Can be played by hand or with lighter sticks  
Recommended for use with the MEINL Low Hat

4.



CA18CR

Size 18"  
Material B20 Bronze  
Features Hand-hammered  
Brilliant finish  
Cutting bell sound  
Great crash sound

6.

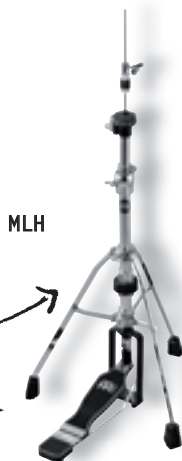

MLH

Special low height!

NEW!



Material Chrome plated steel  
Features Special low height  
Made just for cajon players

Cymbals & Gear

# Realplayer Steelbells

MEINL's Realplayer Steelbells are hand made using a special steel alloy. The parts are welded together in a continuous seam and sealed with a protective coating.

## 1. ARTIST SERIES RUSS MILLER (patent pending)

The Russ Miller "Multi-Bell" enables multiple tones and is a breakthrough in versatility. You can adjust the amount of ring to your desired level with just a turn of a knob. This innovation brings out the most in a cowbell!

1.



**RM80B**

Size 8" big mouth  
 Material Special steel alloy  
 Features Adjustable interior dampening mechanism (patent pending)  
 Hammered  
 Finish Hand brushed black

Adjustable interior dampening mechanism (patent pending)



Russ Miller, USA

## 2. HAMMERED MODELS

The strong fundamental tone of these Steelbells make them a unique alternative to all other bells on the market. Each Steelbell has its own character.

## 3. ARTIST SERIES KENNY ARONOFF

Kenny Aronoff says: "My Artist Series Signature Cowbells are the ultimate drummer's bells. Playing live they cut through and have very nice tones. Their recording characteristics are outstanding, too."

## 4. CHROME FINISH MODELS

These highly polished chrome finished models are not only visually bright, they also satisfy all of the sonic requirements for South American rhythms.

## 5. STEEL FINISH MODELS

The pitches of these Steelbells form a diatonic scale which makes it easy to use multiple bell combinations in any musical setting.

2.

Extra thick welded joint for long durability



**STB625HH-G**



**STB80BHH-G**



**STB625HH-C**



**STB80BHH-C**

Hammered

new!



**STB625HH-S**



**STB80BHH-S**

Hammered

3.

Kenny Aronoff



**KA625**

Sizes 6 1/4" 8" small mouth  
 Material Special steel alloy  
 Feature Hammered  
 Finish High polished chrome



**KA80S**



Kenny Aronoff USA

Thorsten Knell





Jost Nickel, Germany



Extra thick welded joint for long durability

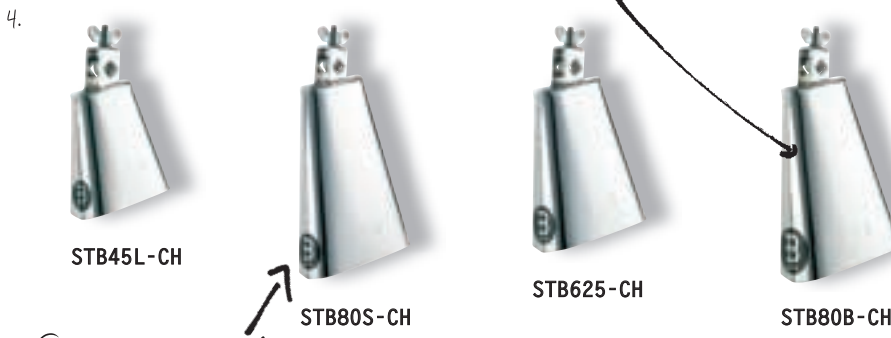

Sizes 4 1/2" low pitch  
6 1/4"  
8" small mouth  
8" big mouth

Material Special steel alloy

Feature Bright sound

Finish High polished chrome

Special steel alloy for a bright sound



Sizes 4 1/2" low pitch  
4 1/2" medium pitch  
4 1/2" high pitch  
6 1/4"  
8" small mouth  
8" big mouth

Material Special steel alloy

Feature Tonally matched

Finish Hand brushed steel

Easy mountable

Jair

Hand brushed steel finish !!!

Gerald Maurer

Pia Weiße

Amadou Diallo

Leon Miguél

*Realplayer Steelbells*

ARTIST SERIES (Russ Miller), HAMMERED MODELS, ARTIST SERIES (Kenny Aronoff)  
CHROME FINISH MODELS, STEEL FINISH MODELS

# Cowbells & Blocks

## 1. BLACK FINISH MODELS

The MEINL Black Finish Models cowbells have been especially designed to meet all of the requirements of today's modern percussionists and drum set players.

## 2. TRIPLE BELL

The three pitch-matched bells combined in one unit, offering modern percussionist a variety of new playing options.

## 3. HEADLINER® SERIES COWBELLS

Made from black powder coated steel, the MEINL Headliner® Series Cowbells produce a cutting and sharp sound. Whether used in a percussion setup or in a drum set configuration, they always add a special flavour to your groove.

## 4. HAND MODELS

These Bongo Bells easily cut through any high volume environment and are comfortable to hold. They are perfect for a classic bongo pattern.

## 5. HANDMATE

The MEINL Handmate is a professional cowbell beater which can be mounted in a set-up. This allows hitting the cowbell by hand while playing another instrument.

## 6. COWBELL BASS DRUM HOLDER

The MEINL Cowbell Holder attaches firmly to the bass drum hoop. Rubber pads prevent scratches on the hoop.



SL475-BK

SL525-BK

SL850-BK

Sizes	4 3/4" 5 1/4" 8 1/2"
Material	Special steel alloy
Feature	Muffled sound
Finish	Black powder coated steel



SLTRI-BK

Sizes	2 1/2" 3 1/2" 5"
Material	Special steel alloy
Feature	Muffled sound
Finish	Black powder coated steel



HC04BK

HC02BK

Sizes	5" 8"
Material	Black powder coated steel
Colour	BK = Black

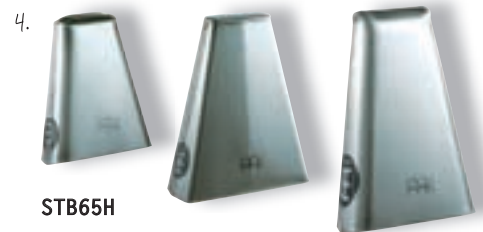

STB65H

STB785H

STB815H

Sizes	6.5" 7.85" 8.15"
Material	Special steel alloy
Finish	Hand brushed steel

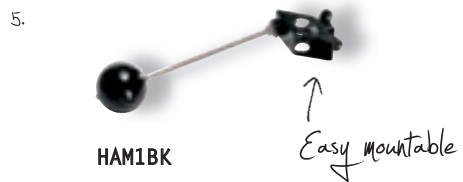

HAM1BK

Material	Steel construction with a wooden ball
Feature	Fully adjustable

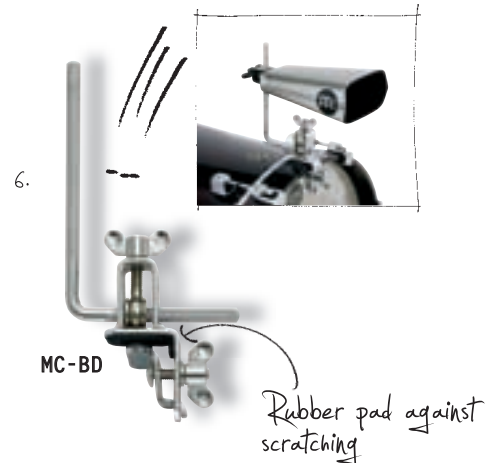

MC-BD

Material	Chrome plated steel
Features	Fully adjustable Rubber pads against scratching
Includes	L-shaped rod

For cowbell beaters see page 115



Mareike Wagner

Cindy



Norbert Seckl

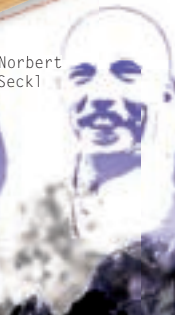

Andrea



Geouf Court



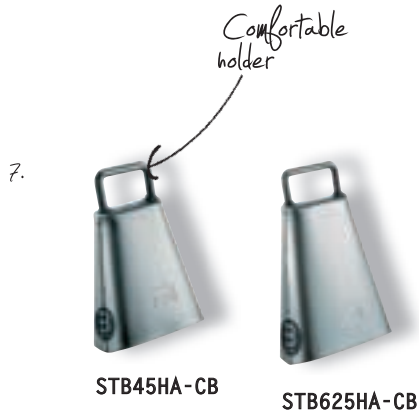

Sizes    4 1/2"  
          6 1/4"  
Material Special steel alloy  
Feature    Comfortable holder  
Finish    Hand brushed steel



Sizes    4 1/2"  
          6 1/4"  
Material Aluminum  
Features Light weight construction  
          Comfortable rectangular grip

## 7. HANDHELD MODELS

The unique feature of the MEINL Handheld Models is a wide and comfortable grip. Ideal for street percussion.

## 8. HANDHELD MODELS, ALUMINUM

Another true MEINL innovation! They are the perfect handheld bells for Samba music due to their light weight and comfortable grip which keeps the player from tiring, allowing for energetic playing.

## 9. PERCUSSION BLOCK, HIGH PITCH

The MEINL Percussion Block is made to withstand even the hardest hitting players. It delivers a cutting high pitched sound.

## 10. PERCUSSION BLOCK, LOW PITCH

This MEINL Percussion Block delivers a low pitched sound and is easily mounted on any conventional L-rod.



Material PE  
Features High pitched sound  
          Durability  
Includes Mounting Clamp  
Colour    BK = Black



Material PE  
Features Low pitched sound  
          Durability  
Includes Mounting Clamp  
Colour    R = Red

## 11. WOOD BLOCK HOLDER

A special holder is available to include the MEINL Wood Blocks into any drum- or percussion set-up. It can be fixed to any common L-rod.

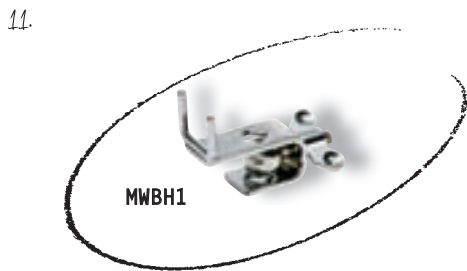

Material Chrome plated steel



Sizes    Small, large  
Material Rubber Wood  
          (Hevea brasiliensis Muell.-Arg.)  
Feature Rounded playing surface  
Includes Wooden beater  
Colour    BK = Black  
Finish    Matte

Alexander  
Urdaneta

Luce

Steffen Sommer

Vladimir  
Zagitov

*Cowbells & Blocks*

# Chimes

MEINL Chimes provide great tonal effect and are available in a wide assortment of sounds. All MEINL Chimes are made from a premium anodized aluminum alloy, and a well balanced wooden bar. Durable nylon cord is used to hang them securely.



Luis Conte, USA

Premium anodized aluminum alloy



LC60HF

All bars are attached through a nylon cord

f.c. Conte

Size 60 bars, double row  
Material Silver anodized aluminum alloy  
Feature High frequency chime  
Includes Holder Striker

## 1. ARTIST SERIES (Luis Conte)

"I wanted a wide spectrum!" comments Luis Conte.  
"The shorter bars deliver great high pitched sounds. I can get a full and bright chime sound from the medium and low pitched bars. They sound perfect especially in the studio."

## 2. CHIMES, 66 BARS

The 66 bar chimes produce a rich and full sound. They cut through any band setting.

## 3. CHIMES, 36 BARS

With bars made from hand polished aluminum, these chimes produce a sound that is clear, bright, and rich in volume and expression.

## 4. CHIMES, 33 BARS

The 33 bar chimes produce a very bright sound with a pronounced upper overtone spectrum. They are perfect for all live situations.

## 5. ROCK CHIMES, 33 BARS

The bars of MEINL Rock Chimes are thicker for a richer and more voluminous sound.

## 6. CHIMES, 27 BARS

The 27 bar chimes produce a full sound with a wide tonal spectrum. Ideal for smaller stages and club scenes.

## 7. STUDIO CHIMES, 27 BARS

The Studio Chimes feature slightly thinner bars for a full, rich and delicate sound.



CH66HF

Size 66 bars, double row  
Material Gold anodized aluminum alloy  
Feature High frequency chime  
Includes Holder Striker



All trusses are made from Jamjuree Wood



CH36

Size 36 bars, single row  
Material Silver anodized aluminum alloy  
Includes Holder Striker

Comes with striker

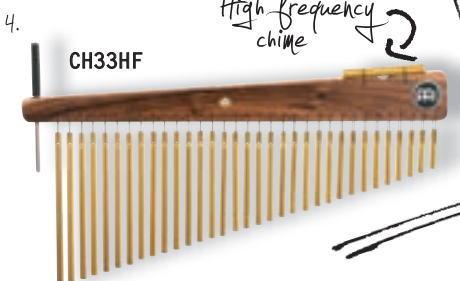

CH33HF

Size 33 bars, single row  
Material Gold anodized aluminum alloy  
Feature High frequency chime  
Includes Holder Striker

High frequency chime



CH33HF-R

Size 33 bars, single row  
Material Gold anodized aluminum alloy  
Feature High frequency chime  
Includes Holder Striker



CH27

Size 27 bars, single row  
Material Gold anodized aluminum alloy

7.

**CH27ST**



**Size** 27 bars, single row  
**Material** Gold anodized aluminum alloy

8.

**CH12**



**Size** 12 bars, single row  
**Material** Gold anodized aluminum alloy

**8. CHIMES, 12 BARS**

The 12 bar chimes produce a beautiful, high pitched sound. Not too obtrusive, ideal for tasteful chime accents.

**9. HEADLINER® SERIES CHIMES, 27 BARS**

The MEINL Headliner® Series Chimes are a great and affordable addition to any percussion set-up! They are made from high quality materials and produce a full and warm chime sound.

9.

**HCH1R**



**Size** 27 bars  
**Material** Silver anodized aluminum alloy

10.

**HCH2BK**



**Size** 33 bars  
**Material** Silver anodized aluminum alloy

11.

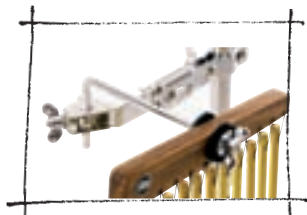

**MC-CHL**

**Sizes** Regular  
Large  
**Material** Chrome plated steel  
**Features** Knurled surface  
Foam washer



**MC-CH**

13.

**MCHB**



**Material** Heavy duty padded nylon  
**Features** Stores up to 2 chimes  
Carrying grip  
Inner velcro straps  
2 internal pockets

2 internal pockets with inner velcro straps



**NEW!**

12.

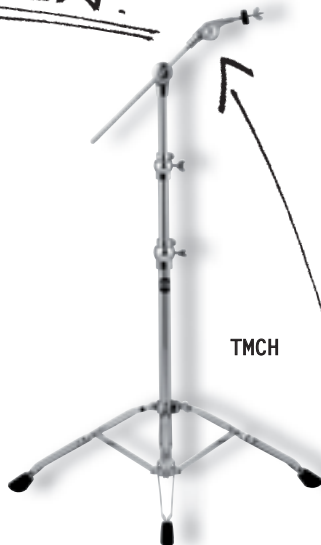

**Material** Chrome plated steel  
**Features** Full angle and height adjustability  
Secure angle clamps  
Telescoping stem

**10. HEADLINER® SERIES CHIMES, 33 BARS**

The new MEINL Headliner® Series Chimes have 33 silver-anodized bars for a full sound spectrum. The curved black truss beam and the silver bar chimes look great in any percussion setup.

**11. CHIMES HOLDERS**

These two differently sized MEINL holders comfortably place the chimes within a drum or percussion set-up.

**12. CHIMES STAND**

Our new Chimes Stand is a fully-adjustable, double-braced tripod stand, specially designed for mounting bar chimes just the way you want them to be held! Made from sturdy chrome-plated steel for dependability. Special padding eliminates unwanted movement, and rubber feet prevent slipping.

**13. PROFESSIONAL CHIMES BAG**

The MEINL Chimes Bag fits all common chime models and is the perfect solution for transporting these valuable precision instruments. Inner velcro straps hold the instrument in place while two internal pockets secure them.

Specially designed to hold chimes, not cymbals!

*Chimes*

# Hand Percussion

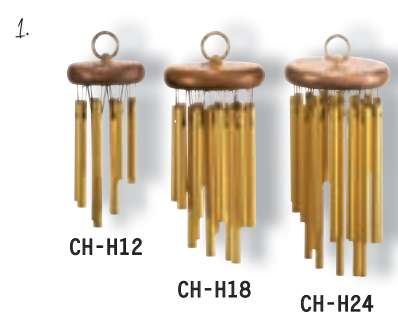

Tonally matched

Sizes 12 bars  
18 bars  
24 bars  
Material Gold anodized aluminum alloy

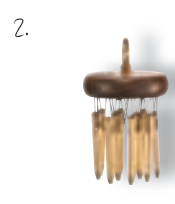

Size 12 pegs  
Material Gold plated steel

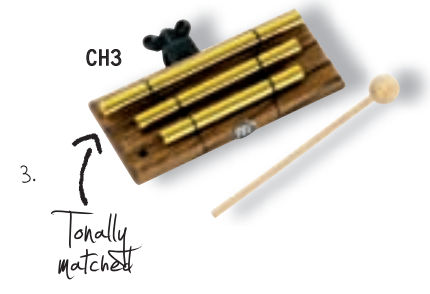

Material Gold anodized aluminum alloy  
Feature Mountable on all common L-rods  
Includes Wooden beater Holder

## 1. HAND CHIMES

The three differently sized models of hand chimes are tonally matched. They can easily be played by hand only and still produce a full and rich sound.

## 2. PEG CHIMES

The Peg Chimes are extremely high pitched. They are perfect for special accents.

## 3. TRI TONE CHIMES

The three free-floating bars create a very long sustain and are tonally matched.

## 4. TRIANGLES

The solid brass triangles produce a nice sounding soft tone with a controlled sonic spectrum.

## 5. TRIANGLE HOLDER

The MEINL Triangle Holder is a simple but effective way to place the triangle in the percussion set-up.

## 6. PROFESSIONAL FINGER CYMBALS

Made from a special bronze alloy and attached with a durable cord, these professional finger cymbals are relatively heavy in weight producing a high pitched and cutting, pure ping sound.

## 7. HANGING FINGER CYMBALS

Strung on a durable cord and made from a special bronze alloy, 14 unique finger cymbals produce a shimmering chorus effect.

## 8. FINGER CYMBALS

Measuring 2 3/8" in diameter, they are easy to hold and comfortable to play.

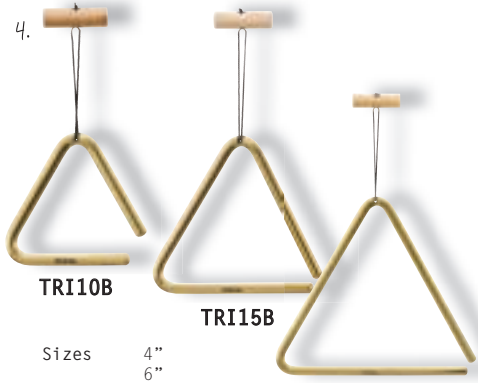

Sizes 4"  
6"  
8"  
Material Solid brass  
Includes Wooden holder with braided nylon cord  
Metal beater



Material Chrome plated steel  
Features Knurled surface  
Nylon cord



Size 2 3/8" diameter  
Material Special bronze alloy  
Features Durable cord  
Shimmering sound

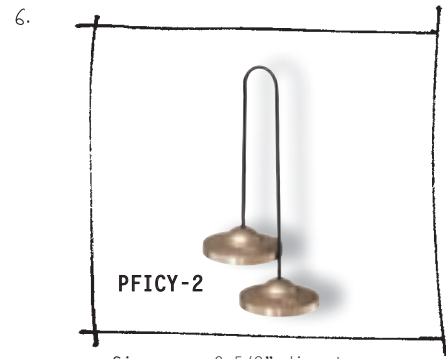

Size 2 5/8" diameter  
Material Special bronze alloy  
Features Identical, high pitched sound  
Durable cord



Sizes Small - g# c f f c  
Medium - a c c a A f e e b  
Materials Chrome plated steel  
Rubber Wood  
(Hevea brasiliensis Muell.-Arg.)  
Feature Ergonomic shape



Special bronze alloy

Size 2 3/8" diameter  
Material Special bronze alloy  
Features Identical in pitch  
Durable rubber band connection

Jan Ole Morfeld

10.

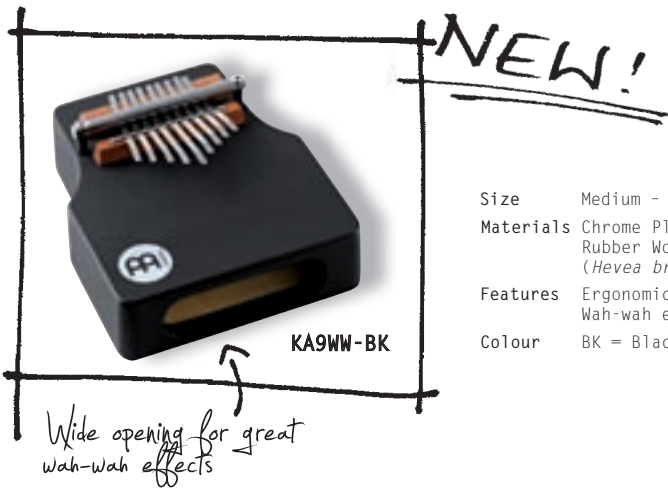

Size Medium - a' c" c' a" A f' e' e" b'  
 Materials Chrome Plated Steel  
 Rubber Wood  
 (Hevea brasiliensis Muell.-Arg.)  
 Features Ergonomic shape  
 Wah-wah effect  
 Colour BK = Black

Pickup system with volume control from **Shadow**

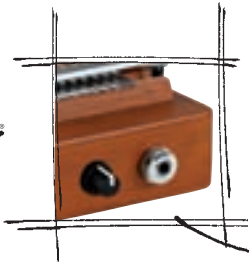

Size Medium - a' c" c' a" A f' e' e" b'  
 Materials Chrome Plated Steel  
 Rubber Wood  
 (Hevea brasiliensis Muell.-Arg.)  
 Features Pickup system with external volume control from Shadow  
 Sound port on upper surface  
 Wah-wah effect  
 Colour AB = African Brown

11.

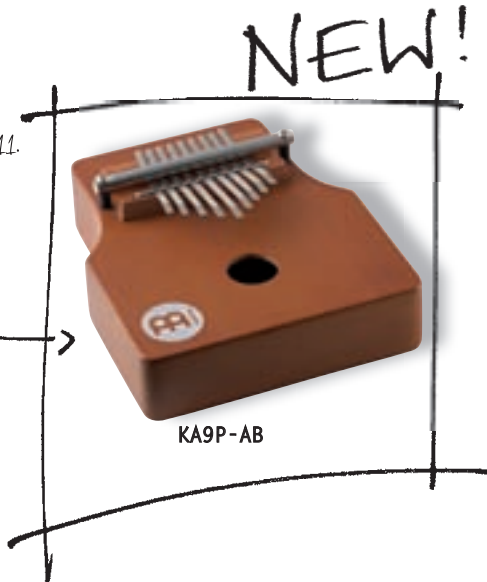

KA9P-AB

12.

K01AM

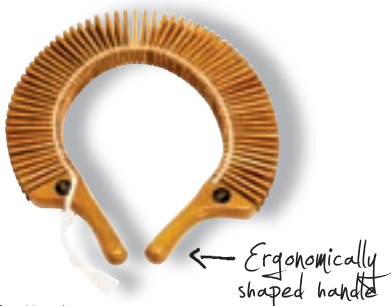

Material Wood  
 Features K01AM:  
 Ergonomically shaped handle  
 Durable cord

K02AM/BK



Features K02AM/BK:  
 Ergonomically designed handgrips  
 Wide, stable binding strap in real leather  
 Colours AM = Amber  
 AM/BK = Amber/Black

13.



Materials Solid brass bells  
 Wooden handle  
 Includes Striker

9. KALIMBAS

MEINL Kalimbas are great sounding melodic instruments in a compact size! Solid construction, plated steel keys and an ergonomic shape makes these kalimbas dependable musical tools. The sound is pure joy, and a great addition to any percussion kit.

10. WHA-WHA KALIMBA

Everybody loves a little wha-wha ... So we came up with a kalimba with a body-oriented sound hole in place of the traditional style. You can create a great wha-wha effect by simply bouncing the kalimba body on and off your belly as you play. The position is comfortable and natural, while the sound gets shifted in creative ways.

11. PICKUP KALIMBA

We put a pickup into our kalimba to boost the output, so your melody can carry on. The internal pre-amp means you won't have to worry about playing up close to the mike. An external volume knob lets you easily adjust to any situation.

12. KOKIRIKOS

The Kokiriko originated in Japan as a sound effect instrument. It produces a rattling effect which can be an almost silent rustling to an extremely loud catter.

13. HAND HELD BELL TREE

The MEINL Bell Tree (Hand Held Bell Tree) has a cascade of 14 solid brass bells securely mounted on a wooden handle. Depending on how you choose to play it, the Bell Tree can be a melodic, rhythmic, or chromatic instrument.

14. STAND ALONE BELL TREE

The MEINL Bell Tree has 27 solid brass bells mounted on a sturdy metal stand. The extra large chromatic cascade of bells may also be played rhythmically or melodically.

14.

BT27



Material Solid brass bells  
 Feature Adjustable metal stand  
 Includes Striker



*Hand Percussion*

# Shakers

Bill Saragosa  
inventor of The Spark Shakers



**SH16**

Size	Medium
Materials	Shaker: Coated steel Pellets: Coated steel
Finish	Black nickel

Circular motion enables a unique rattling sound



**SH17**

Size	Medium
Materials	Shaker: Coated steel Pellets: Coated steel
Finish	Black nickel

Screw-mounted disc enables a tunable pitch

## 1. SPARK SHAKER

The sparkling, chirping, splashing tones readily mix with almost any musical flavour. The pod-like shape fits easily into the hand and may be manipulated for many interesting effects. Spark Shakers may be played in pairs, or in combination with other shakers for even more variations.

## 2. SPIN SPARK SHAKER

The MEINL Spin Spark Shaker is equipped with a screw-mounted disc that adjusts and amplifies the characteristics of the fundamental pitch. When the disc is tight, the pitch is highest; and it deepens as the disc is loosened. There is a distinctively pleasant supplemental timbre.

## 3. HEADED SPARK SHAKER

One side of the MEINL Headed Spark Shaker is a drum head! Premium goatskin and a steel shell provide a rattling combination of crisp warm tones and a bright metal timbre.

3.

**SH18**



Size	Medium
Materials	Shaker: Coated steel Pellets: Coated steel Goat head
Finish	Black nickel

Side view



Sensational effects are produced when combined with another Spark Shaker



4.

High pitch

Low pitch

SH22

Material	Steel
Features	Comes in a set of two Wildly variable pitch response
Finish	Black nickel

#### 4. CLAMSHELL SPARK SHAKERS

The Clamshell Spark Shakers have a single solid weld holding the two halves of the shell together like a hinge. When you squeeze the two halves together, you get a wildly variable pitch response. It comes in two pitches, for high-low combinations.

#### 5. ALUMINUM SHAKERS, OCTAGONAL

MEINL's Octagonal Aluminum Shakers come in three different sizes. All have a broad dynamic range with lots of volume.

#### 6. ALUMINUM JINGLE SHAKER

The MEINL Aluminum Jingle Shaker (designed by Juan Carlos Melian) has two pairs of steel jingles which are attached in one row to an octagonal aluminum shaker.

5.

SH8BK                      SH88BK                      SH888BK

NEW!

Sizes	Small Medium Large
Material	Aluminum
Colour	BK = Black



Ron van Stratum, Netherlands

Juan Carlos Melian, Spain



6.

JS88BK



By tilting the shaker 90° to the front the jingles start to click on the beat

Inventor

Size	Medium
Materials	Shaker: Aluminum Jingles: Steel
Colour	BK = Black



Daria-Maret Geller

Sanpo

Coutouly Davy

Shakers

# Shakers

## 1. STUDIO SHAKER

MEINL's Studio Shaker was designed to meet all the requirements necessary in today's session world. It delivers a very tasteful and delicate shaker sound with a warm overall tone and a very well balanced frequency spectrum.

## 2. FIBERGLASS SHAKERS

These MEINL Shakers are made from premium fiberglass for more durability and better sound quality. They are light weight and very comfortable to play.

## 3. ALUMINUM SHAKERS, ROUND

The MEINL Round Aluminum Shakers were designed to cut through loud live music. Available are two different versions.

## 4. SHAKER HOLDER

The MEINL Shaker Holder (designed by Jen Lowe) firmly attaches to any common rod. With its length adjustable specially shaped claws it holds any size shaker in a comfortable position for quick reach.

## 5. WOOD SHAKERS

Made from a combination of selected woods, these new MEINL Wood Shakers offer a nice array of alternative sounds.

## 6. RAWHIDE SHAKER

The MEINL Rawhide Shaker combines two different materials into one unique instrument. It produces very experimental sounds and works perfectly in modern music productions.

## 7. U.F.O. SHAKERS

The black MEINL U.F.O. Shaker produces an extreme mellow and smooth sound and less attack, while the grey version has a crisper sound with more volume.

1.

SH10-L-BK



Size Large  
Material Plastic  
Colour BK = Black

2.

SH7-M-BK

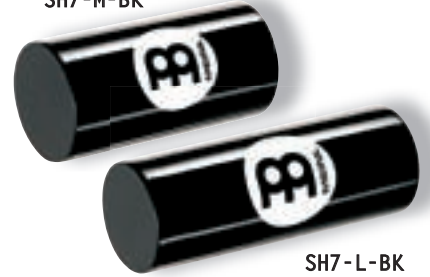

Sizes Medium  
Large  
Material Premium fiberglass  
Colour BK = Black

3.

SH9-L-S

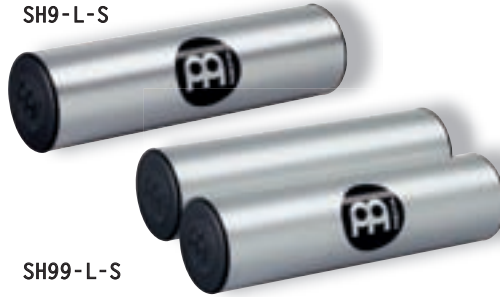

SH99-L-S  
Size Large  
Material Anodized aluminum  
Features Available as a single, or double shaker  
Colour S = Silver



4.

MC-SH

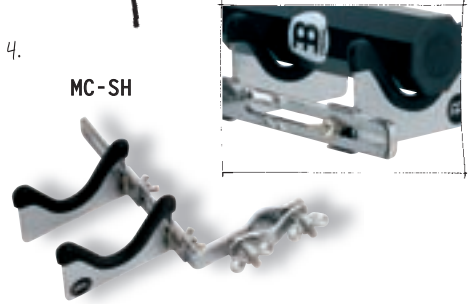

Material Chrome plated steel  
Features Rubber pads against scratching  
Length adjustable  
Strong mounting clamp

5.

SH15-S



SH15-M



SH15-L



Black Makah-Burl

Wooden body enables a soft and warm sound

Sizes Small  
Medium  
Large

Materials Rubber Wood  
(*Hevea brasiliensis* Muell.-Arg.)  
Top and Bottom: Black Makah-Burl

6.

SH6-S-BK



Two different materials produce experimental sounds

Size Small  
Materials Plastic with natural rawhide side caps  
Colour BK = Black

7.

SH21BK



Crisper sound with more volume

SH21GR



Extreme mellow →

Size Medium  
Material Plastic  
Colours BK = Black  
GR = Grey

**NEW!**

Jennifer Gluth and Martin Kiebling

Maximilian Raumschüssel and Sarah Neeß

8.

SH20BK



By covering and uncovering the sound hole, a "wah-wah" effect can be achieved

Size Medium  
Materials Wooden body and plastic chamber  
Colour BK = Black

9.

SH3BK



Loud and penetrating sound due to the many holes (US patent)

Size Medium  
Material Plastic  
Colour BK = Black

### 8. WAKAH SHAKER

The MEINL Wakah Shaker is another unique and innovative instrument, offering yet another voice to a percussionist's range of sounds. The shaker has two chambers which are separated by a plastic membrane.

### 9. LOOP SHAKER (US patent)

The MEINL Loop Shaker has a crackling bright sound with many dynamics, and is easy to control. It is very responsive to hand pressure and movement, giving it a soft or loud voice as needed.

### 10. ARTIST SERIES SHAKERS (Luis Conte)

The three versions have been designed according to master percussionist Luis Conte's exact requirements. "My shaker sound is as smooth as silk" is how Luis described their sound.



Luis Conte USA

... as smooth as silk!

L. Conte

10.

SH4BK



More voluminous yet delicate sound

Size Medium  
Material Plastic  
Feature Two individual shakers connected as one instrument

SH5R

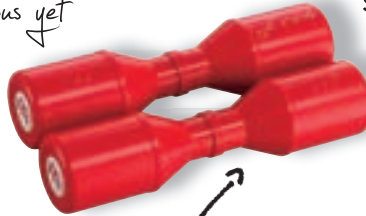

Very subtle and smooth tone

Colours Live Shaker: BK = Black  
Studio Shaker: R = Red  
Stadium Shaker: GR = Grey

Extra loud projection



SH45GR

Shakers

# Hand Percussion

## 1. PLASTIC EGG SHAKERS

The MEINL Plastic Egg Shakers are preferred due to their smooth and crystal clear sound. These have applications in practically any musical setting.

## 2. WOOD EGG SHAKER

The MEINL Wood Egg Shaker is turned from wood and deliver a soft yet rich sound. It's perfect in situations which require clearly defined accents.

## 3. DOUBLE SHAKER

The MEINL Double Shaker is woven by hand. It offers two different sounds in one instrument.

## 4. CAXIXIS/GANZA

The MEINL Caxixis/Ganza are woven by hand with a coconut bottom. Their sound is crystal clear, high pitched with a great projection.

## 5. WOOD MARACAS

The traditional MEINL Wood Maracas are available in both round and oval models. Both of these exhibit a traditional warm and rich sound.

## 6. RAWHIDE MARACAS

The MEINL Rawhide Maracas are entirely made by hand and are offered in three different sizes for a wide sonic range. The two larger models sound especially full and dry, whereas the smaller sized version produces a very tight and high pitched sound.

1.



Material Plastic  
Colours B = Blue  
BK = Black  
GREEN = Green  
R = Red  
Y = Yellow

2.

ESW-J-BK



Size Jumbo  
Material Wood  
Colour BK = Black

3.

DO1



Coconut bottom for increased projection

4.



Materials Rattan with coconut bottom

CAX2

GA2

5.

MWM1MC



6.

MSM4



Natural rawhide

Material Wood

MWM2AM

Sizes Mini  
Traditional  
Jumbo

Materials Natural rawhide  
Wooden handle

MSM2

Nils Graßnick

Chiko

Maddison Jones

Daniel Neves

Matthew Modder

*Marina Chabanova  
Ukraine*



7.

PM2BK



Materials Plastic  
Wooden handle

7. PLASTIC MARACAS

The MEINL Plastic Maracas produce a loud and crisp sound. They are very durable and comfortable to play.

8.

GU7R



GU7BK



*3 playing surfaces*

Material Premium fiberglass  
Features Three striking surfaces  
Padded grip holes  
Includes Plastic scraper  
Colours BK = Black  
R = Red

8. FIBERGLASS GUIROS

The MEINL Fiberglass Guiros offer three different striking surfaces for enhanced sounds and padded grip holes.

9. PLASTIC GUIRO

The MEINL Plastic Guiro is precision molded from high strength plastic. It features three different striking surfaces and rubber ringed grip holes for maximum comfort and control.

9.

GU6BK



Material High strength plastic  
Features Three striking surfaces  
Rubber ringed grip holes  
Includes Plastic scraper  
Colour BK = Black

10. WOOD GUIROS

The traditional MEINL Wood Guiros are available in two different versions and produce a warm and cutting sound.

10.

GU2AB-M



Material Wood  
Features Three striking surfaces  
Grip holes  
Includes Plastic scraper  
Colour AB-M = African Brown  
Finish Matte

11. GUIRO HOLDER

The MEINL Guiro Holder firmly attaches to any common rod and holds the guiro securely in place while it is played.

11.

MC-GU

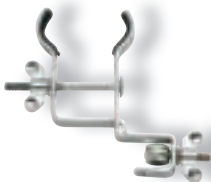

Material Chrome plated steel  
Feature Rubber pads against scratching

GU1AM



Material Wood  
Feature Grip holes  
Includes Wooden scraper  
Colour AM = Amber

*Hand Percussion*

# Cabasas



Joannie Labelle, Canada



Material Chrome plated steel  
Features Strong mounting clamp  
Padded surface

### 1. CABASA HOLDER

This unique attachment holds the cabasa safe and ready to use. The padded surface prevents it from slipping.



Sizes Small, regular, large  
Materials Steel chain and stainless steel cylinder  
Wooden handle with padded soft grip  
Feature 5 sound ports on each side for more volume (German and US patent)  
Colour BK = Black

### 2. TURBO CABASAS (German and US patent)

The MEINL Turbo Cabasas are a great innovation, with significantly more volume than normal cabasas. This comes from the sound ports in the resonating chamber. The Turbo Cabasas bring the classic cabasa sound to a new level that will cut through any sonic environment.

### 3. FOOT CABASA (US patent)

The MEINL Foot Cabasa is a breakthrough instrument for the percussionist! We mounted a large Turbo Cabasa on our sturdy foot pedal (US patent), which adds a new sound to your setup. Keep a cabasa rhythm while your hands play the congas or other drums! The MEINL Foot Cabasa can be set for either a single or double-stroke, according to your taste.

Torsten Franz



Size Large  
Materials Steel chain and stainless steel cylinder  
Wooden body  
Black powder coated pedal  
Features Optional single or double-stroke setting  
5 sound ports on each side for more volume (US patent)  
Includes Drum key  
Foot pedal

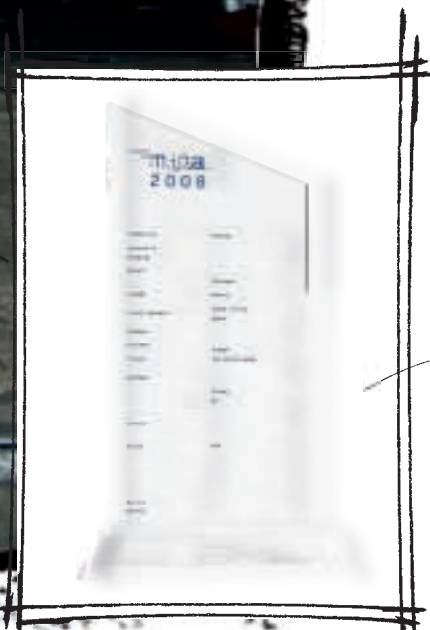

The Meinl Foot Cabasa won "the MIPA Award in the "Best Percussion Product" category.

Cabasas

# Ritual Drums

MEINL combines traditional instruments with modern technology and innovations. The range of Ritual Drums is a line of instruments which originate many different cultures from all around the world. MEINL's R&D expertise helped in creating these authentic and high quality instruments which are outstanding in the percussion world.

## 1. BERIMBAU

The MEINL Berimbau is traditional African instrument that is a commonly found in the music from Brazil and other South American countries. The thin striker and a caxixi are held in the right hand, while the left hand supports the bow and modulates the string with a small metal disc. The whole instrument is moved off-and-on the abdomen, opening and closing the resonant gourd, for a captivating "wah-wah" effect.

1. BE1R



**Material** Premium fiberglass  
**Includes** Small Caxixi  
 Metal plate  
 Wooden stick  
 Carrying bag  
**Colour** R = Red

## 2. CABASA, FIBERGLASS

The shape and function of the MEINL Fiberglass Cabasa equals a traditional gourd calabash.

## 3. TALKING DRUM

The Talking Drum has its origin in West Africa. The traditional technique involves squeezing the tuning ropes while striking the head with a thin bent wooden mallet.

2.

CA7R



**Material** Premium fiberglass  
**Colour** R = Red

*Adjustable net for various tensions and sound options*

3.

TD7BK

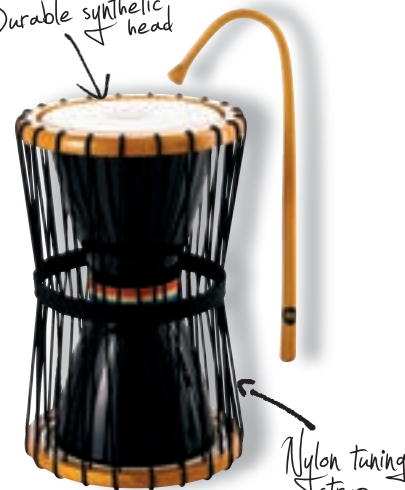

**Size** 7 1/2"  
**Material** Premium fiberglass  
**Features** Durable synthetic heads  
 Wooden rims  
 Nylon tuning strap  
**Includes** Curved wooden beater  
**Colour** BK = Black

*Durable synthetic head*

*Nylon tuning strap*

*Hu Gang, China*



Zarubin Andrey

Sebastian

Murilo Santana Saraiva

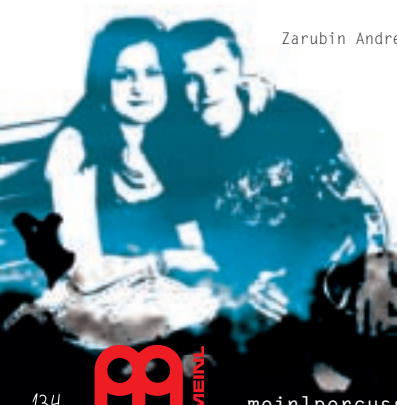



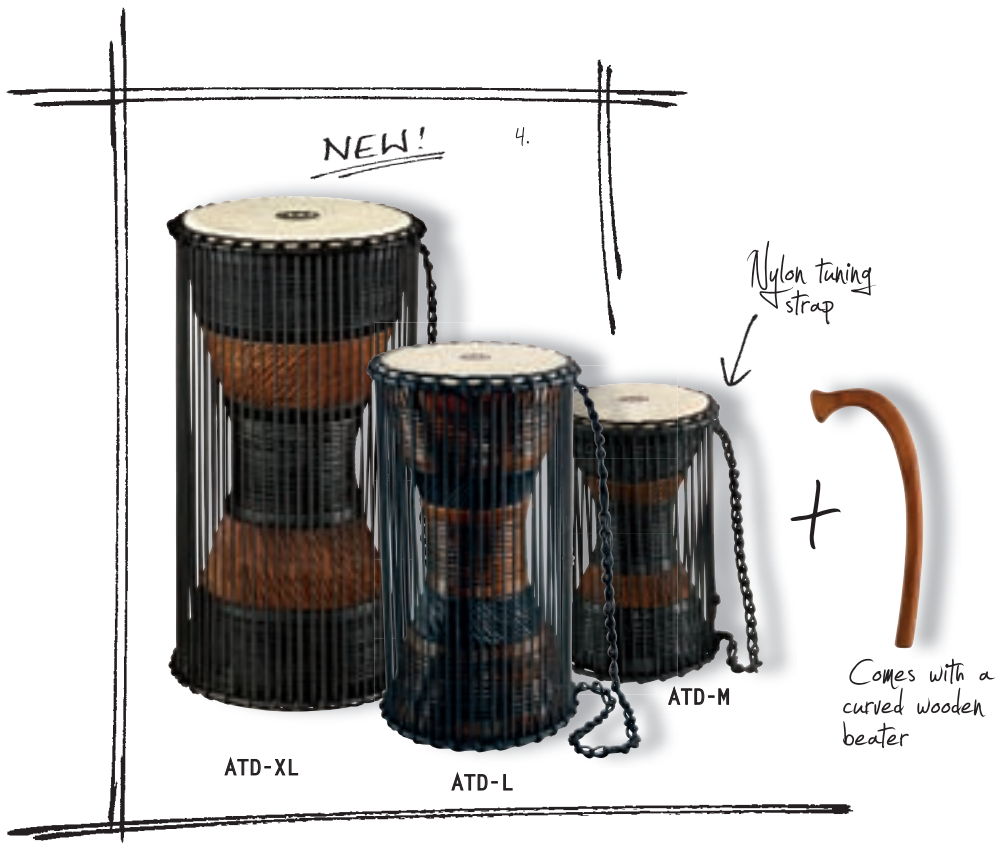

#### 4. AFRICAN TALKING DRUMS

MEINL African Talking Drums are carved into an hourglass shape from a solid piece of Mahogany wood, and decorated with a carved motif. Two hand-selected goatskin heads are spanned with high-quality nylon rope. Traditionally, the talking drum is played beneath one arm, and held against the ribcage. The drum is then squeezed to "bend" the pitch while the other hand employs a curved striker.

#### 5. SHEKERE, JUMBO SIZE

MEINL's Jumbo Size Shekere is hand made from premium fiberglass and fitted with a net of beads.

#### 6. SHEKERE

The MEINL Shekere is handmade from premium fiberglass and fitted with a net of beads. It delivers a crisp sound and unlike gourd shekeres, it is nearly unbreakable.

**Sizes** M = 7" x 12"  
 23 rope runners, 3 mm PP rope  
 L = 8" x 16"  
 28 rope runners, 3 mm PP rope  
 XL = 9" x 20"  
 34 rope runners, 3mm PP rope

**Materials** Mahogany Wood  
 Hand selected goat heads

**Features** Carved from one solid piece of plantation grown Mahogany Wood  
 Nylon tuning strap  
 Ornamental carving

**Includes** Curved wooden beater

**Finish** Brown/Black

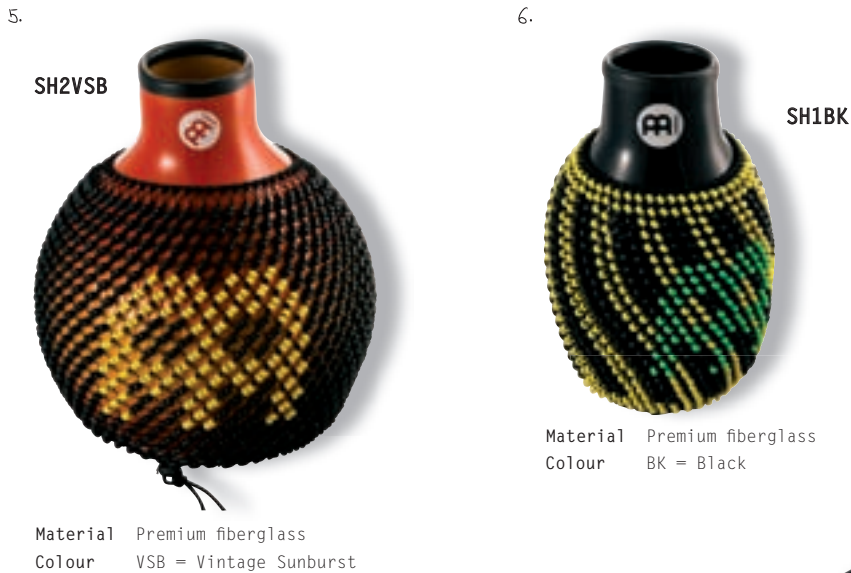

Ritual Drums

# Ritual Drums

## 1. TABLA

The MEINL Tabla is made in the time-honored Indian tradition. Multi-ply natural skin heads are secured by metal rings and rawhide verticals. Proper tuning is achieved by adjusting wooden rollers that are fitted under the rawhide verticals.

## 2. PROFESSIONAL TABLA SET

A top-of-the-line professional quality tabla set. Our tablas are made according to their classical heritage, and are superbly crafted. The tones are unsurpassed for their clarity and character. These are Tablas that will make any player proud.

Chrome plated copper

1.



Bayan

TABLA

Dayan



Sizes 5 1/2"  
8 1/2"  
Materials Chrome plated copper with goat skin  
Rosewood with goat skin  
Features Authentic tabla heads  
Traditional tuning system with rawhide leather strings  
Includes Padded support rings  
Tuning hammer  
Nylon bag

Top-of-the-line professional tabla set!  
Made by a master craftsman in India



2.

**NEW!**

PRO-TABLA



Sizes 5 1/2"  
8 1/2"  
Materials Copper with goat skin  
Mahogany with goat skin  
Features Top quality goat skin tabla heads  
Traditional tuning system with rawhide thongs  
Includes Tuning hammer and wooden tuning dowel  
Ring pads  
Protective head covers

Omitola



Angelika Kramer



3.



MTA1SNT-M



Size 11"  
 Material Rubber Wood  
 (Hevea brasiliensis Muell.-Arg.)  
 Features True Skin Buffalo Heads  
 Black powder coated hardware  
 Includes Nylon strap  
 Wooden beaters  
 Tuning key  
 Colour SNT-M = Super Natural  
 Finish Matte

Nylon strap

4.



RAMWONG7

Traditional rope tuning system

Size 7" diameter, 10" tall  
 Material Wood  
 Features Natural rawhide  
 Traditional rope tuning system

5.

HCG89NT



Hand selected buffalo head

Sizes 8" & 9"  
 Material Rubber Wood  
 (Hevea brasiliensis Muell.-Arg.)  
 Features 8 mm strong tuning lugs  
 Original MEINL style tuning brackets  
 Traditional rims  
 Black powder coated hardware  
 Hand selected buffalo heads  
 Includes Height adjustable tilting  
 double braced tripod stand  
 Tuning key  
 Wrench  
 Colour NT = Natural  
 Finish High gloss

Heavy duty stand can be tilted

3. TAMBORA

The rhythm of the Merengue has its roots in the Dominican Republic where the use of a Tambora drum is essential in creating this style of music.

4. RAMWONG

Ramwong is a Thai folk dance which evolved from Ramthone, a popular festive season in a certain region in Thailand. Ram means dance and Thone is a small drum.

5. WOOD CONGUITAS

The Conguitas are a perfect addition to any percussion set up. They are made from high quality materials and produce a cutting and strong percussive tone which complements the congas in a harmonically supportive sound spectrum.

6. BATAS

The MEINL Batas are made from premium fiberglass for more durability, lighter weight and comfortable playing, and have a traditionally authentic sound.

6.

BA1BK



BA2BK



BA3BK



Hand selected buffalo heads



Sizes Okonkolo 5 1/4" & 8"  
 Itotele 5 3/4" & 8 3/4"  
 Iya 6 3/4" & 12"  
 Material Premium fiberglass  
 Features Hand selected buffalo heads  
 Traditional TTR-Rims

Includes Nylon strap  
 Tuning key  
 Colour BK = Black

Dani

Ravinderjit Singh



Ritual Drums

# Bill Saragosa Line

## 1. LIQUID TRIANGLE

The MEINL Liquid Triangle is a solid steel triangle, welded securely to a steel shell, creating a chamber which contains liquid and is closed with a very thin plate. The triangle portion may be played in the classical manner, while the chamber creates eerie resonant overtones.

1.



**Material** Special steel alloy, filled with water  
**Feature** Wide sound spectrum  
**Includes** Metal beater  
**Finish** Black nickel

## 2. HELIX BOWL (Patent Pending)

The MEINL Helix Bowl is a wonderful new instrument consisting of a steel helix welded to a resonating chamber. The Helix Bowl is either stroke or struck, and is played off the body in the manner of a berimbau, for a deep resonating wah-wah effect. Optional dampening is possible with just a touch of a finger.

2.



*Inventor*

*Bill Saragosa, not from this world*

## 3. CONE-STACK

The MEINL Cone-Stack is a four-chambered shaker with some wild characteristics. Two balanced chambers are connected with a center screw, and may be played as a pair, or as one shaker. As a pair, they have a high and a low side, plus an open bell, also tuned high and low. They can be played like maracas. Screw them together, and you get a kind of multi-chambered stereo effect! It's a great, full sound with metallic overtones. You can play it sort of like a shekere, or wah-wah the open bell chambers, or clasp it in the middle balance point for fine shaker techniques.

3.

**Material** Special steel alloy  
**Includes** Metal beater  
**Finish** Black nickel



## 4. GALAXY

4.



**Material** Special steel alloy  
**Features** Ergonomic form  
Wide sound spectrum  
**Includes** Padded striker  
**Finish** Black nickel

## 4. GALAXY

Two resonant liquid chambers are connected by a long steel spiral. The Galaxy is held in one hand, while the other hand holds a beater, and it may be played something like a classical triangle. By slightly altering the position of the Galaxy, liquid inside the two chambers exerts variable dampening on the thin steel resonator plates.

**Material** Special steel alloy  
**Feature** A set of two  
**Finish** Black nickel

*Very funky!*

# Ritual Drums

1.  
RA7BK



**Material** Premium fiberglass  
**Feature** Circular construction  
**Includes** Ergonomically shaped handle  
**Colour** BK = Black

3.  
WW1BK



**Sizes** Small (high pitch)  
 Large (low pitch)  
**Material** Aluminum  
**Includes** Rubber mallet  
**Colour** BK = Black

2.  
DDG1-BK



Made out of real Bamboo

**Size** 47" long (120 cm)  
**Material** Bamboo  
**Includes** Nylon bag  
**Colours** BK = Black  
 R = Red

1. RAINMAKER

The MEINL Rainmaker is uniquely different. Due to the circular construction, it can be mounted on a cymbal stand and by simply turning the instrument a drizzle can immediately change into the sound of a monsoon.

2. DIDGERIDOOS

MEINL Didgeridoos are a great way to get started on the oldest wind instrument in the world. It makes a distinctive drone with harmonic overtones, and goes great with all kinds of percussion. Our didgeridoos are made from Bamboo.

3. WAH-WAH TUBES

The MEINL Wah-Wah Tube is a tubular effect instrument that delivers smooth, bell-like tones with an incredible sustain.

4. SYNTHETIC DIDGERIDOOS

The new MEINL Synthetic Didgeridoos are a modern twist on the traditional bamboo construction. They are extremely durable and are unaffected by weather so they are perfect for outdoor use.

NEW!

SDDG1-BK



Made out of lightweight synthetic

4.

**Size** 51" (130 cm)  
**Material** Lightweight synthetic  
**Includes** Nylon bag  
**Colours** BK = Black  
 R = Red

Dan Haffar



SDDG1-R

Hayley Bell



Ritual Drums

# Ritual Drums

## 1. BIRDS/WATERFALL, FIBERGLASS

The MEINL Birds and Waterfall realistically imitate the sound of a flock of birds or a rippling waterfall. By using fiberglass a bright sound is produced, the dynamic range is increased and an optimum durability is realized.

## 2. BIRDS/WATERFALL, WOOD

The MEINL Birds and Waterfall made out of Rubber Wood enable a brighter timbre and a more penetrating sound.

## 3. RAINSTICKS

Natural Bamboo makes our Rainsticks pleasant effect instruments, with plenty of projection and long sustain. They may be played like big shakers as well.

## 4. SYNTHETIC RAINSTICK

The MEINL Synthetic Rainstick is light in weight and extremely durable.

## 5. BIRDS/WATERFALL WITH HANDLE

The MEINL wooden Birds and Waterfall pod rattles are our popular sound effects now woven onto a handgrip. The result is a hand-held pod rattle with full control.

## 6. FOOT RATTLE

The MEINL Foot Rattle goes with everything. Marks pulse with moderate volume and warmth.

1. BI7RY



WA7BK



Material Premium fiberglass  
Feature Durable cord

2. BI1NT



WA1NT



Material Rubber Wood (Hevea brasiliensis Muell.-Arg.)  
Feature Durable cord  
Colour NT = Natural

3.



Sizes 16" (40 cm)  
24" (60 cm)  
39" (100 cm)

Material Bamboo  
Colours BK = Black  
R = Red

4.



Size 39" (100 cm)  
Material Lightweight synthetic  
Colour R = Red

5.

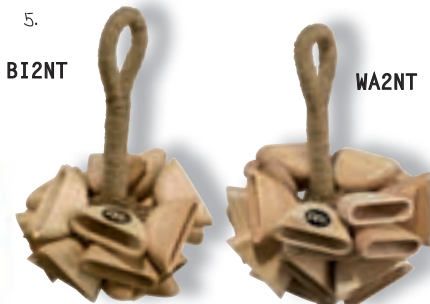

Material Rubber Wood (Hevea brasiliensis Muell.-Arg.)  
Feature Handle made out of natural cord  
Colour NT = Natural

6.



Material Rubber Wood (Hevea brasiliensis Muell.-Arg.)  
Feature Velcro strap  
Colour NT = Natural

Elke



Chantal Sander

7. **CL18** *Made from superb, dense hardwood*



Size 6 3/4" long  
 Material Hardwood  
 Features Cutting sound  
 Convenient carrying

8. **CL7R**



*Fiberglass produces the loudest and most cutting sound of all*

Material Premium fiberglass  
 Features Solid body  
 Cutting sound  
 Colour R = Red

9. **CL1HW**



**CL1RW**



Materials HW = Hardwood  
 RW = Redwood  
 Feature Solid body

7. CLAVES DE LUXE

The MEINL Claves De Luxe are made from a superb, dense hardwood which delivers a cutting and bright tone. Due to their small size, they are portable and convenient but still enable a loud, solid rhythmic foundation on stage and in studio sessions.

10. **CL2HW**



**CL2RW**



Materials HW = Hardwood  
 RW = Redwood  
 Features CL2 = Solid body  
 CL3 = Hollowed out body

8. FIBERGLASS CLAVES

The MEINL Fiberglass Claves produce the most penetrating, loud, and cutting sound of all. They are hand made from premium fiberglass which makes them nearly indestructible.

**CL3HW**



**CL3RW**



9. WOOD CLAVES, CLASSIC

The MEINL Classic Wood Claves are the most common claves and produce the classic cutting sound. Both the clave and the striker have the same size.

10. WOOD CLAVES, AFRICAN

African Claves are slightly larger and have a lower fundamental pitch. Additionally, the resonating body is larger than the striker. Available in two different versions: Solid and hollowed out body.

11. **NI1AM**



Materials Solid steel balls and cylinder  
 Wooden body  
 Feature Ergonomically shaped handle  
 Colour AM = Amber

12.

*Fiberglass delivers a drier and louder sound*

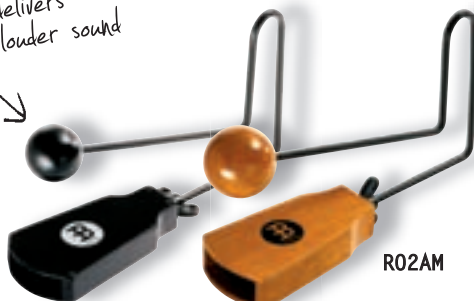

**R01BK**

**R02AM**

Materials Wood or premium fiberglass  
 Feature Solid construction

*Wood produces a warm crisp tone*

11. THE NIGHT

When playing The Night, four solid steel balls hit a cylindrical metal rod in quick succession producing the unique sound of crickets.

12. THE ROAR

The MEINL Roar is available as a wood and as a fiberglass version. A rattling effect is achieved by striking the ball end against the palm of the hand.

# Ibo Drums

The MEINL Ibo Drums perfectly combine tradition with modern innovation. "Ibo" is the Nigerian name for "pottery" where these unique drums originate. They all have a wide spectrum of sounds, are easy to play and offer many great features.

## 1. FIBERGLASS LIQUID IBO DRUM

A sealed metal chamber containing water is permanently bonded to the premium fiberglass body. The liquid chamber adds fluctuating overtones to the drum's fundamentals. It's easy and it's fascinating! The liquid fluctuations give you new sounds at every turn of the hands.

1.

ID9BK/WH



Size	Large
Material	Premium fiberglass
Features	Special bottom, filled with water Built-in microphone hole Resistant shell construction
Includes	Foam padded base
Colour	BK/WH = Black/White

*The Fiberglass Liquid Ibo Drum is filled with water*

## 2. FIBERGLASS IBO DRUM

The MEINL Fiberglass Ibo Drum has a wide variety of different sounds and the fiberglass body makes it nearly unbreakable.

2.

ID1BKR



*Built in microphone hole*

ID2BKR



*Resistant shell construction*

Size	Large
Material	Premium fiberglass
Features	Built in microphone hole Resistant shell construction
Includes	Foam padded base
Colour	BKR = Black/Red

Size	Long neck
Material	Premium fiberglass
Features	Built in microphone hole Resistant shell construction
Includes	Foam padded base
Colour	BKR = Black/Red

## 3. FIBERGLASS IBO DRUM, LONG NECK

The MEINL Fiberglass Ibo Drum with long neck has a wide variety of different sounds and the fiberglass body makes it nearly unbreakable.

## 4. FIBERGLASS TRI SOUND IBO DRUM

The MEINL Tri Sound Ibo Drum features an additional rawhide playing surface and an extra thin bottom for enhanced sound.

4.

ID3GO



*Rawhide playing surface*

## 5. FIBERGLASS TRI SOUND IBO DRUM

The MEINL Tri Sound Ibo Drum features an additional fiberglass playing surface and an extra thin bottom for enhanced sound.

5.

ID4BK0



*Built in microphone hole*

Size	Large
Material	Premium fiberglass
Features	Rawhide playing surface Built in microphone hole Resistant shell construction
Includes	Foam padded base
Colour	GO = Gold Ornament

*Extra thin bottom for enhanced sound*

*Extra fiberglass playing surface*

## 6. WOOD IBO DRUM

This unique instrument is another true MEINL innovation. It features a wooden body for a wide sonic range.

6.

ID6



*Wood enables a drier sound*

*Hand carved ornaments*

Size	Large
Material	Premium fiberglass
Features	Extra fiberglass playing surface Built in microphone hole Resistant shell construction
Includes	Foam padded base
Colour	BK0 = Black Ornament

Michael Joeschia

Size	Large
Material	Made from Mango Wood (Mangifera Sp.L.)
Features	Dry tones Built in microphone hole
Includes	Foam padded base



Tarcisio Molinaro, Italy



Pia Weiße



7.

**ID7RB**

Full and rich sound due to ceramic body



Size Large  
 Material Ceramic  
 Features Full and rich sounds  
 Built in microphone hole  
 Includes Foam padded base  
 Colour RB = Red/Brown

**7. CERAMIC IBO DRUM**

The ceramic body of this Ibo Drum causes a slight enhancement of the higher frequencies, with fat and powerful bass tones.

**8. PROFESSIONAL IBO STAND**

The MEINL Ibo Stand was designed to enable playing an Ibo Drum in ways other than simply being placed in one's lap, such as standing up or incorporating it into a percussion set up. It can be angled and is fully height adjustable.

**9. CERAMIC IBO DRUM**

The special feature of this MEINL Ceramic Ibo Drum is the fiberglass bottom for extra sound options.

**10. PROFESSIONAL IBO BAGS**

The MEINL Ibo Bag fits all common clay drum models and is the perfect solution for transporting these valuable and fragile instruments.

**11. IBO HOLDER**

The MEINL Ibo Holder securely supports most common ibo drums in a comfortable position while enabling you to play the ibo with both hands, or with one hand free for other instruments.

8.

**TMID**

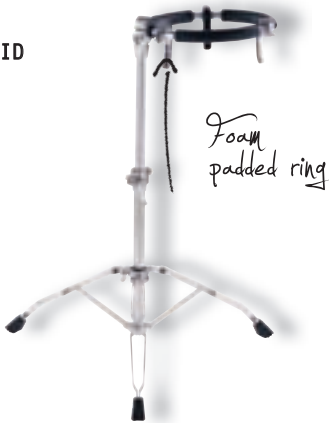

Foam padded ring

Material Chrome plated steel  
 Features Foam padded ring  
 Fully height- and angle adjustable  
 Double braced tripod legs  
 Includes Allen wrench  
 Memory lock

10.

**MIB-S MIB-M**



Sizes Small (9 3/4" W x 13 1/3" H x 9 3/4" D)  
 Medium (11" W x 14 1/2" H x 11" D)  
 Material Heavy duty padded nylon  
 Includes Padded shoulder strap  
 Carrying grip  
 External pocket

9.

**ID8RB**



Extra fiberglass bottom for more sound options



Size Large  
 Material Ceramic  
 Features Fiberglass playing surface  
 Built in microphone hole  
 Includes Foam padded base  
 Colour RB = Red/Brown

11.

**TMIH**



Enables to play the ibo with both hands

Material Black powder coated steel  
 Includes Allen wrench  
 Foam padded base



Robert Lutj, Poland

Karin Studenroth

Ekaterina Belobrova

Fritz Kramer

# Doumbeks

MEINL Doumbeks come from the same geographical points of origin as the darbukas, and are a favourite choice of drum for percussionists world-wide. Our doumbeks feature an ergonomic, Egyptian-style rounded rim with internal tuning lugs and a synthetic head. The bearing edge is carefully machined to assure consistent tuning. The doumbeks are well suited for fast finger-roll techniques and have a strong projection. The shells are constructed from various materials, each offering a wide range of timbres, weights and visual aesthetics.

## 1. PROFESSIONAL DOUMBЕК

A serious player needs a serious instrument! We made our new Professional Doumbek to meet the needs of the most demanding players. It's cast from solid aluminum and is larger and heavier than our regular models. The shell is extra thick for unparalleled clarity and projection.



Size 9" x 19"  
Material Aluminum  
Weight 15.8lbs (7200g)  
Features Synthetic head  
Heavy weight for more playing comfort  
Includes Professional carrying bag  
Tuning key



Size 8 1/2" x 17 1/8"  
Material Copper  
Features Synthetic head  
Hand engraved shell  
Includes Carrying bag  
Spare head  
Tuning key

## 2. COPPER DOUMBЕК, HAND ENGRAVED

The copper shell of this MEINL Doumbek is hand engraved for a stunning look. A very traditionally looking and sounding instrument.

## 3. ALUMINUM DOUMBЕК, HAND ENGRAVED

This aluminum doumbek comes in a ornamental hand graving and produces snappy mid east sounds.



Size 8 1/2" x 17 1/8"  
Material Aluminum  
Features Synthetic head  
Hand engraved shell  
Includes Carrying bag  
Spare head  
Tuning key

## 4. ALUMINUM DOUMBЕК, HAND-HAMMERED

The aluminum shell of this MEINL Doumbek is completely hand-hammered for a most appealing look.



Size 8 1/2" x 17 1/8"  
Material Aluminum  
Features Synthetic head  
Hand-hammered shell  
Includes Carrying bag  
Spare head  
Tuning key

## 5. ALUMINUM DOUMBЕKS

Hand made entirely of aluminum, the MEINL Doumbek is outstanding in sound and quality, reaching from resonant lows to ringing highs. Available in four different finishes.



Black leather-look vinyl wrapped



HE-3020



NEW!



HE-3000BR

Size 8 1/2" x 17 1/8"  
Material Aluminum  
Feature Synthetic heads  
Includes Carrying bag  
Spare head  
Tuning key  
Colours HE-3000 = Black  
HE-3020 = Copper  
HE-3000BG = Beige  
HE-3000BR = Brown

NEW!

6.



HE-3400

Size 8 1/2" x 17 1/8"  
 Material Aluminum  
 Features Synthetic head  
 Wood covered shell  
 Includes Carrying bag  
 Spare head  
 Tuning key

7.



ADB-L

ADB-M

Sizes M = 7" x 12"  
 L = 8" x 16"  
 Material Mahogany Wood  
 Features Carved from one solid pieces of  
 plantain grown Mahogany Wood  
 Pre-tuned goat head  
 Comfortable rounded rim  
 Hand carved ornaments  
 Colour Brown  
 Finish Matte

6. ALUMINUM DOUMBEC,  
 WOOD COVERED

The shell of this MEINL Doumbek is made from aluminum and is completely covered with a layer of the finest wood.

7. WOOD DOUMBECs

The MEINL Wood Doumbeks are great sounding, light weight wooden doumbeks with decorative tribal carving on the foot. Goatskin heads are securely fastened over the Egyptian style bearing rims, which is preferred for finger roll techniques.

8. PROFESSIONAL DOUMBEC BAG

The MEINL Doumbek Bag is made from heavy duty padded nylon with reinforced stitching and is equipped with a double-slide zipper, a padded shoulder strap, and a carrying grip.

9. PROFESSIONAL DOUMBEC STAND

The MEINL Doumbek Stand was designed to enable incorporating a Doumbek into a percussion- or drum set-up. An adjustable, foam padded ring holds the Doumbek Drum firmly and prevents it from sliding or falling down. It can be angled and is fully height adjustable.

8.



MDOB

Material Heavy duty padded nylon  
 Features Double-slide zipper  
 Additional upright zipper  
 Padded shoulder strap  
 Carrying grip  
 External pocket

9.



TMID

Material Chrome plated steel  
 Features Foam padded ring  
 Fully height- and angle adjustable  
 Double braced tripod legs  
 Includes Allen wrench  
 Memory lock



Dado Sezzi,  
 Italy

Max Klaas,  
 Germany

*Doumbeks*

# Darbukas

MEINL Darbukas are made in the tradition of the original, esoteric goblet-shaped drums found in music from Eastern Europe, the Middle East and Southern Asia. Our darbukas are constructed from thin shells in various metals, each metal giving the different models their special timbre. The head is secured and tuned with external rings set close to the shell, in the Turkish-style. Light yet powerful, the darbukas have a deep full bass. They are well suited for high-pitched snapping sounds as well as a wide range of articulated "dum" and "tak" strokes.



Ethnobeat, Russia



Marco Catinaccio, Italy

## 1. ALUMINUM DARBUKAS, PLAIN

These Turkish style MEINL Darbukas feature fat lows and ringing highs with a wide range in between.

## 2. ALUMINUM JINGLE DARBUKAS, HAND-HAMMERED

These MEINL Aluminum Darbukas feature a beautifully hand-hammered shell and built in jingles which adds a nice rattling effect and enhances their sound spectrum tremendously.

1.



Sizes	HE-100 = 5 1/3" x 9 1/4"
	HE-101 = 5 7/8" x 11"
	HE-102 = 6 1/2" x 12 3/4"
	HE-103 = 7 1/4" x 13 1/3"
	HE-104 = 8" x 14 1/2"

Material	Aluminum
Feature	Synthetic heads
Includes	Tuning key

Anne Amrehn



2.



Built in jingles



Ramiro P. Molina



Sizes	HE-314 = 8" x 14 1/2"
	HE-315 = 8 1/4" x 16"
Material	Aluminum
Features	Built in jingles Synthetic heads Hand-hammered shells
Includes	Tuning key

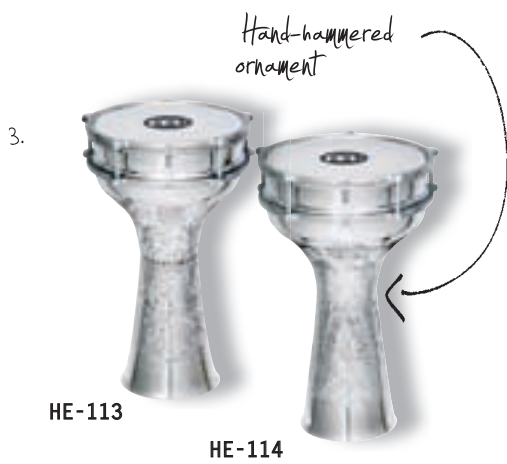

Sizes HE-113 = 7 1/4"x13 1/3"  
HE-114 = 8"x14 1/2"

Material Aluminum

Features Synthetic heads  
Hand-hammered shells

Includes Tuning key



Sizes HE-214 = 7 1/2"x14 3/4"  
HE-215 = 7 7/8"x15 1/2"

Material Copper

Features Synthetic heads  
Hand-hammered shells

Includes Carrying bag  
Spare head  
Tuning key

### 3. ALUMINUM DARBUKAS, HAND-HAMMERED

These MEINL Turkish style Darbukas have a beautifully hand-hammered shell. They offer resonant lows and ringing highs with a wide range in between.

### 4. COPPER DARBUKAS, BRASS PLATED, HAND-HAMMERED

These unique instruments are made entirely of copper with a brass plated- and hand-hammered shell. Strong high tones with resonant lows.

### 5. COPPER DARBUKAS, HAND ENGRAVED

The beautifully hand engraved shell of this copper darbuka is outstanding in sound and look!

### 6. PROFESSIONAL DARBUKA BAG

The MEINL Darbuka Bag is made from heavy duty padded nylon with reinforced stitching and is equipped with a double-slide zipper, a padded shoulder strap, and a carrying grip.



Sizes HE-204 = 7 1/2"x14 3/4"  
HE-205 = 7 7/8"x15 1/2"

Material Copper

Features Natural rawhides  
Hand engraved shells

Includes Carrying bag  
Spare head  
Tuning key



Material Heavy duty padded nylon

Features Double-slide zipper  
Additional upright zipper  
Padded shoulder strap  
Carrying grip  
External pocket



June A. Soto

Vasilyev  
Alexandr

Antoine Sancesario

Caro

Darbukas

ALUMINUM DARBUKAS  
COPPER DARBUKAS, DARBUKA BAG

# Hardware

A professional mounting system requires stability and flexibility. The Original MEINL Hardware features the highest quality workmanship to provide a large variety of set up solutions for both percussionists and drummers alike. A system of well thought out clamps, holders, rods, and attachments for literally any set up or space situation.

1.

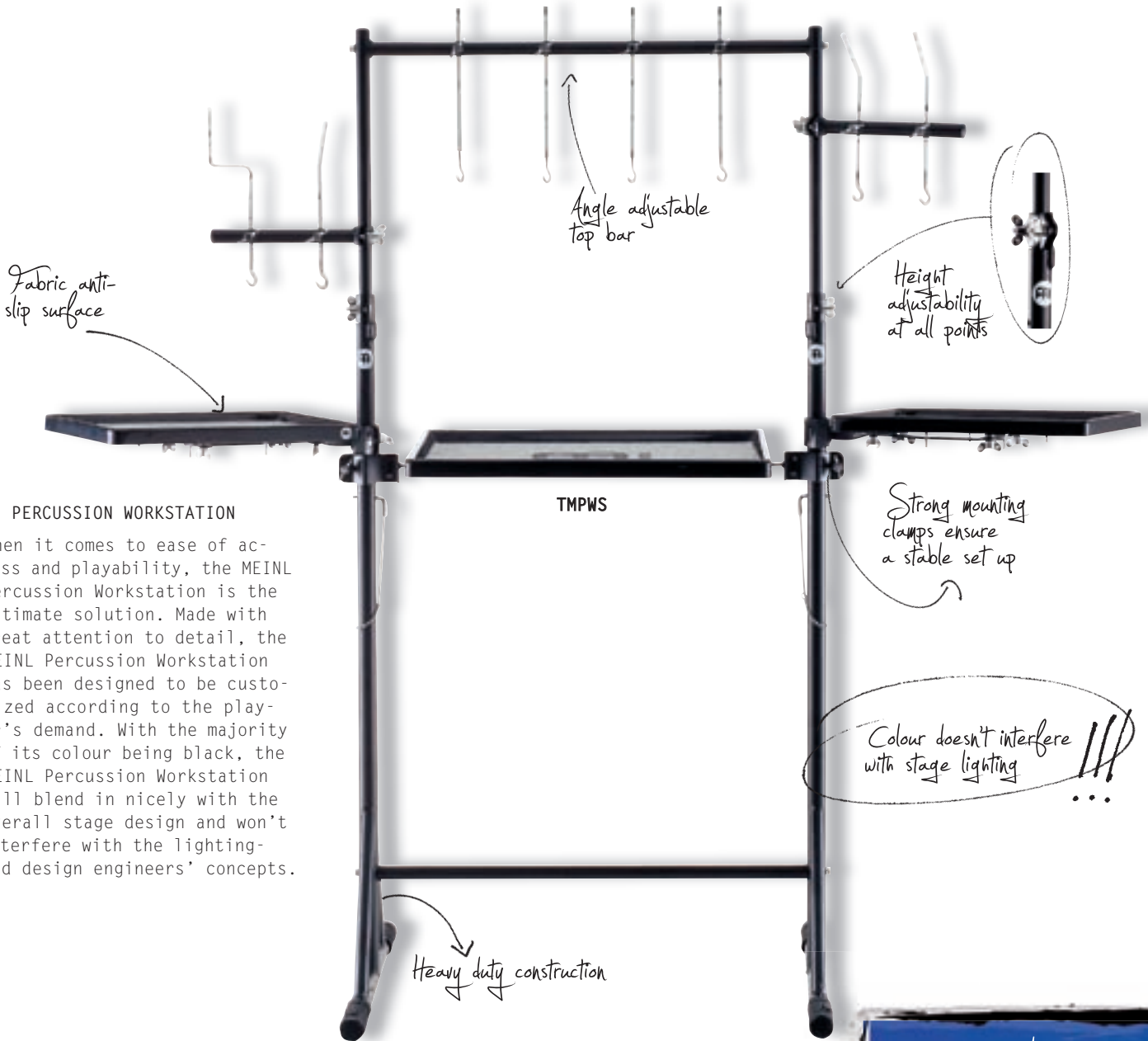

## 1. PERCUSSION WORKSTATION

When it comes to ease of access and playability, the MEINL Percussion Workstation is the ultimate solution. Made with great attention to detail, the MEINL Percussion Workstation has been designed to be customized according to the player's demand. With the majority of its colour being black, the MEINL Percussion Workstation will blend in nicely with the overall stage design and won't interfere with the lighting- and design engineers' concepts.

- Material** Black powder coated steel
- Features** Fully height adjustable  
 Angle adjustable top bar  
 Fabric anti-slip surface  
 Heavy duty construction  
 Infinitely expandable  
 Fabric anti-slip surfaces  
 Colour doesn't interfere with stage lighting

- Includes** 1 pc 22" x 24" padded fiberglass percussion table  
 2 pcs 18" x 12" padded fiberglass percussion tables (attachable)  
 1 pc 30" vertical bar  
 2 pcs 15" vertical bars (attachable)  
 4 pcs straight rods with hook  
 3 pcs angled rods with hook  
 1 pc Z-shaped rod with hook

Femke Krone, Netherlands



Biggi

Tugba Kayaaslan

Mike Wilcox





**NEW!**

**Sizes** 20" x 34"  
**Materials** Table: Premium fiberglass  
 Stand: Chrome plated steel  
**Features** Fabric anti-slip surface  
 Padded edge  
 Fully height adjustable  
 Ergonomic shape for more efficiency  
 Double braced tripod legs  
**Includes** Allen wrench  
 Memory lock

*Ergonomic shape for more efficiency*

*Inventor* →

**TMPETS**

## 2. ERGO TABLE

Our new Ergo Percussion Table was invented by Meinl Percussion artist Taku Hirano, and it's designed for efficiency and stealth. The curved shape helps you to fit it into your set-up with no space wasted, while keeping everything within easy reach. The inner raised edge is padded, so that instruments may be picked up and set down with an absolute minimum of contact noise. Double braced legs keep it all secure and stable.



Taku Hirano, USA

*Strong mounting clamp*



**MC-DSH**

**Materials** Chrome plated steel  
 Black textile pouch  
**Feature** Strong mounting clamp

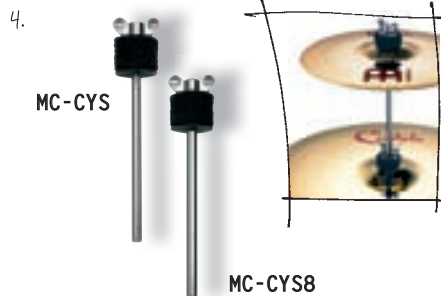

**MC-CYS**

**MC-CYS8**

**Sizes** MC-CYS = ø 6 mm  
 MC-CYS8 = ø 8 mm  
**Material** Chrome plated steel  
**Feature** Felt washers

## 3. DRUMSTICK HOLDER

The MEINL Drumstick Holder firmly attaches to any common stand and stores a number of drumsticks, mallets, brushes and other accessories in its roomy pouch for ready access when needed.



**MC-CY**

**Material** Chrome plated steel  
**Features** Knurled surface  
 Felt washers

## 4. CYMBAL STACKERS

The MEINL Cymbal Stackers enable a space saving set up of various cymbals on top of each other.

## 5. CYMBAL HOLDER

This MEINL holder comfortably places any cymbal within a drum or percussion set up.



Silvester Steines

Eric Schaffner

Sylvi Schaffner

*Hardware*

# Tables & Stands

## 1. PERCUSSION TABLES

The MEINL Percussion Tables are made from durable fiberglass and offer enough room for all common hand percussion instruments. It can be attached to all common stands. Through its innovative design the angle of the table can be adjusted.

1.

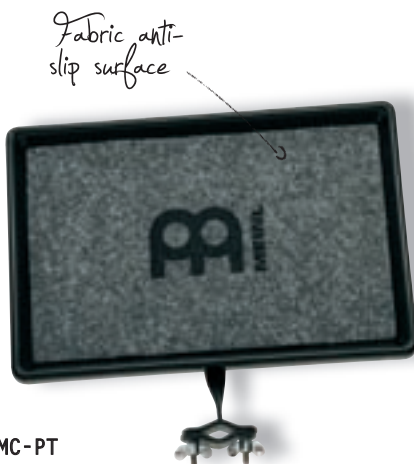

MC-PT

**Sizes** MC-PT = 18"x12"  
MC-PTS = 12"x12"  
**Material** Premium fiberglass

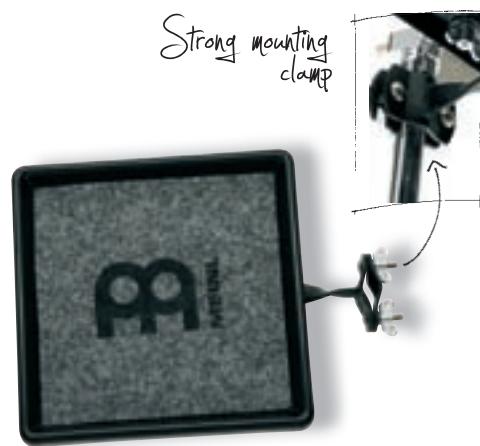

MC-PTS

**Features** Fabric anti-slip surface  
Adjustable angle  
Strong mounting clamp

## 2. PERCUSSION STAND

The MEINL Percussion Stand is a universal device which offers a variety of set up solutions for both drummers and percussionists. It is fully height adjustable and features both quick locks and memory locks for a quick set up.

2.

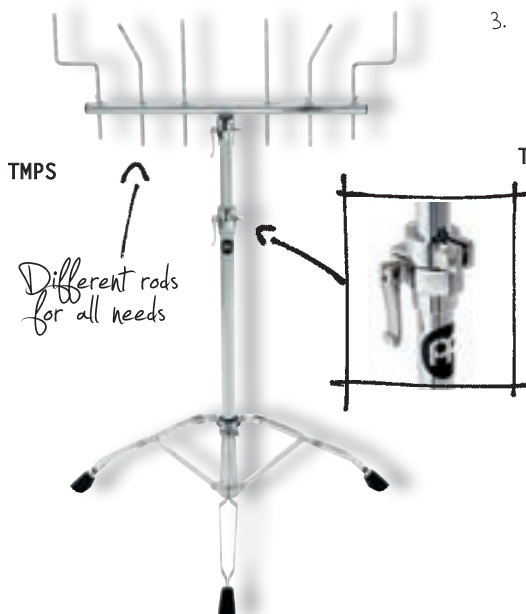

TMPS

Different rods for all needs

3.

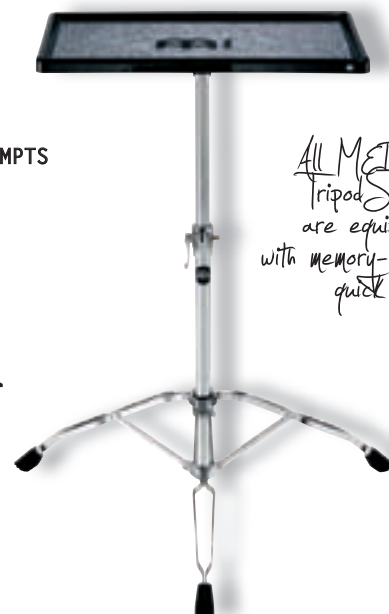

TMPTS

All METAL Tripod Stands are equipped with memory- and quick locks

## 3. PERCUSSION TABLE STAND

The MEINL Percussion Table Stand offers enough room for all common hand percussion instruments. It is fully height adjustable and has a fabric anti-slip surface.

## 4. PEDAL MOUNT

The MEINL Pedal Mount fits on all common bass drum pedals and firmly holds cowbells, blocks, or tambourines. It is height adjustable and contains metal spikes attached to the bottom of the legs, holding the entire unit in place without movement.

**Material** Chrome plated steel  
**Features** Height adjustable  
Double braced tripod legs  
**Includes** Allen wrench  
Memory locks  
2 straight rods  
2 angled rods  
2 Z-shaped rods

**Size** 16" x 22"  
**Materials** Table: Premium fiberglass  
Stand: Chrome plated steel  
**Features** Fabric anti-slip surface  
Fully height adjustable  
Double braced tripod legs  
**Includes** Allen wrench  
Memory lock



Dirk Anton

Norbert Seckl

Cindy

Andrea

4.

PM-1



Metal spike for more stability

**Material** Black powder coated steel  
**Features** Height adjustable legs  
Metal spikes attached to the bottom of the legs  
**Includes** 2 differently sized L-rods



# Bars & Clamps

5.

MC-1

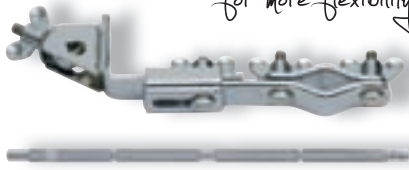

*Length adjustability for more flexibility*

**Material** Chrome plated steel  
**Features** Length adjustable  
 Strong mounting clamp  
**Includes** Straight rod

6.

CLAMP



**Material** Chrome plated steel  
**Feature** Compact and solid design

5. MULTI CLAMP, ONE MOUNT

The MEINL Multi Clamp easily attaches to any common stand. Its unique feature is the length adjustability to fit any given space situation. It holds one rod.

6. CLAMP

The MEINL Percussion Clamp attaches to the lug of a conga, bongo, or djembe for mounting an additional cowbell, block, or tambourine.

7.

MC-2



**Material** Chrome plated steel  
**Features** Length adjustable  
 Strong mounting clamp  
**Includes** 2 straight rods

8.

PMC-6

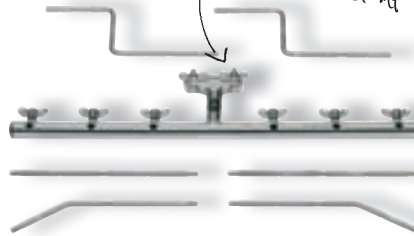

*Strong mounting clamp*

**Material** Chrome plated steel  
**Includes** 2 straight rods  
 2 angled rods  
 2 Z-shaped rods

7. MULTI CLAMP, TWO MOUNTS

The MEINL Multi Clamp easily attaches to any common stand. Its unique feature is the length adjustability to fit any given space situation. It holds two rods.

8. MOUNTING BAR, 6 PCS.

The MEINL Mounting Bar can easily be attached to any stand. It's ideal for expanding your percussion or drum set up.

9.

MC-4

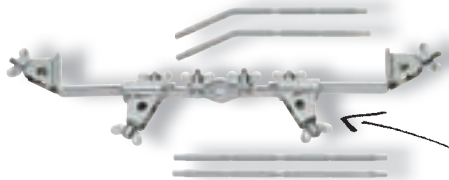

**Material** Chrome plated steel  
**Features** Length adjustable  
 Strong mounting clamp  
**Includes** 2 straight rods  
 2 angled rods

*Length adjustability for more flexibility*

9. MULTI CLAMP, FOUR MOUNTS

The MEINL Multi Clamp easily attaches to any common stand. Its unique feature is the length adjustability to fit any given space situation. It holds four rods.

10. RODS

A variety of differently shaped rods can hold several mountable hand percussion instruments.

10.

MC-R1

MC-R2

MC-R3

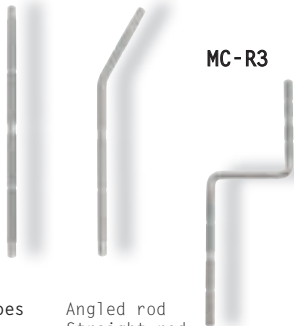

**Shapes** Angled rod  
 Straight rod  
 Z-shaped rod  
**Material** Chrome plated steel  
**Features** Knurled surface



*Christian Einbeller, Austria*

*Hardware*



# NINO®

## FIRST MOVE

The new generation of musical instruments for early childhood education. NINO® instruments meet exactly the requirements of early childhood education and are perfectly suitable for use in kindergartens, schools, music therapy, and for musical activities at home. Easy handling and an appealing design are standard for all NINO® instruments. They are noteworthy due to their professional features, great sounds and their outstanding quality. The strong, childproof workmanship guarantees years of trouble-free use of all NINO® instruments.

All NINO® products are designed for children ages three years and up.

# THE SAFETY

NINO® instruments have been tested by the Landesgewerbeanstalt Bayern, Germany (LGA), Institute for the Testing of Goods and Quality Monitoring and have been awarded with the LGA Test Certificate.

This means that NINO® instruments comply with the strict requirements of the European Community Directives 88/378EC and 87/357/EC.

## PRODUCT TESTING

All NINO® instruments are regularly tested for safety and sanitary harmlessness according to the EC Directives 88/378/EC (Toy Safety Directive) and 87/357/EC (Imitation of Food). The tests are carried out by the Landesgewerbeanstalt Bayern, Germany (LGA), a modern testing and consulting services organization with over 30 branches worldwide. As a recognized institute for the testing of goods and quality monitoring, the LGA is entitled to award the GS and LGA test marks which are accepted throughout Europe and internationally as a guarantee of safety.

## NINO® INSTRUMENTS PASS THE FOLLOWING TESTS

Testing in dependence on the Toy Safety Directive (88/378/EC)
Mechanical and physical characteristics
Inflammability
Migration of certain parts
Saliva and perspiration resistance
Colorfastness
Determination of the content of Pentachlorophenol (PCP)
Testing with regard to pesticides
Valuation in accordance with EC Directive 87/357/EC
Standard Consumer Safety Specification on Toy Safety
Consumer Product Safety Improvement Act of 2008

## CERTIFICATION

After passing all tests, the internationally accepted LGA Test Certificate was awarded for all NINO® percussion instruments. This certificate vouches for quality and safety.



## DIRECTORY

PRODUCT GROUP	PAGE
Congas	154
Bongos	156
Cajons	157
Frame Drums	158
Hand Percussion	160
Shakers	168
Nino® Sets	170
Nino® Rhythm Sets	171
ABS Drums	172
Djembes	174
Shake'n Play	176
Glockenspiels	177

*Nino® Percussion*

FIRST MOVE

# Congas

NINO® Congas are famous for their professional workmanship in fiberglass or wood sets. They all include basket stands and can therefore be played individually or in a set configuration.

## 1. NINO® DESIGNER SERIES CONGA SET - MUSICAL ZOO

NINO® Musical Zoo Designer Series Conga Set is decorated with a delightful collection of musical friends. They send a positive message about music making and fun!

## 2. FIBERGLASS CONGA SET

Our fiberglass is a high quality material, manufactured by hand, into especially powerful sounding shells. The advantage over wood congas is the lower weight which makes handling much easier.

## 3. NINO89 WOOD CONGA SET

The NINO89 Wood Congas can be played standing up or sitting down and are therefore the perfect congas for children in kindergartens.



### NINO89MZ

Sizes	8" & 9" 22" tall
Material	Rubber Wood with appliqué graphics ( <i>Hevea brasiliensis</i> Muell.-Arg.)
Features	Hand selected buffalo heads Rounded rims for playing comfort Black powder coated hardware
Includes	Basket stands Tuning key
Finish	MZ = Musical Zoo

2.

Hand selected buffalo head

3.

Can be played standing up due to the height



### NINO89F-HK

Sizes	8" & 9" 22" tall
Material	Premium fiberglass
Features	Hand selected buffalo heads Rounded rims for playing comfort Black powder coated hardware
Includes	Basket stands Tuning key
Colour	HK = Harlekin®



### NINO89NT

Sizes	8" & 9" 22" tall
Material	Rubber Wood ( <i>Hevea brasiliensis</i> Muell.-Arg.)
Features	Hand selected buffalo heads Rounded rims for playing comfort Black powder coated hardware
Includes	Basket stands Tuning key
Colour	NT = Natural

4.



NIN0910DS

**Sizes** 9" & 10"  
28" tall

**Material** Rubber Wood with appliqué graphics  
(*Hevea brasiliensis* Muell.-Arg.)

**Features** Hand selected buffalo heads  
Rounded rims for playing comfort  
Black powder coated hardware

**Includes** Height adjustable basket stands  
with quick set up system  
Tuning key

**Finish** DS = Deep Sea

*NINO® Wood Congas  
are equipped with strong  
tuning brackets*

4. NINO® DESIGNER SERIES  
CONGA SET - DEEP SEA

The NINO® Deep Sea Designer Series Conga Set make a splash! Friendly fish characters send a positive message about making music and having fun together.

5. NIN0910 WOOD CONGA SET

The NIN0910 Wood Congas are ideal for first time players or schools. Height adjustable stands included.

6. NINO® CONGA BAG

The NINO® Conga Bag is designed to supply reliable protection while transporting the instrument. It holds congas up to 10" diameter.

*The rounded rim offers perfect  
playing comfort without harming  
the wrist or palm*

5.



*Height  
adjustable*

NIN0910NT

**Sizes** 9" & 10"  
28" tall

**Material** Rubber Wood  
(*Hevea brasiliensis* Muell.-Arg.)

**Features** Hand selected buffalo heads  
Rounded rims for playing comfort  
Black powder coated hardware

**Includes** Height adjustable basket stands  
with quick set up system  
Tuning key

**Colour** NT = Natural

6.



*Shoulder  
strap* →

MNCOB

**Size** Up to 10"

**Material** Padded nylon

**Features** External pocket  
Shoulder strap  
Carrying grip

*Congas*

# Bongos

1.

*Rounded rim for playing comfort*



**NINO3NT-BK**

**NINO3NT-HK**

**Sizes** 6 1/2" & 7 1/2"  
**Material** Rubber Wood  
*(Hevea brasiliensis Muell.-Arg.)*  
**Features** Hand selected buffalo heads  
 Rounded rims for playing comfort  
**Includes** Tuning key  
**Colours** NT-BK = Natural Shell/  
 Black Hardware  
 NT-HK = Natural Shell/  
 Harlekin® Hardware

2.

## 1. WOOD BONGOS

The NINO® Wood Bongo is an affordable yet high quality instrument with great versatility in sound. Children love the coloured Harlekin® design!



**NINO17R-BK**

**NINO17B-BK**

## 2. ABS BONGOS PLUS

A real alternative! The NINO® ABS Bongo Plus is an affordable bongo with a great sound and functional hardware. Shells made of ABS plastic make this bongo lighter than comparable wood models.

*The tuning system is outstanding in this price range*

**Sizes** 6 1/2" & 7 1/2"  
**Material** ABS plastic  
**Features** Hand selected buffalo heads  
 Rounded rims for playing comfort  
 Black powder coated hardware  
**Includes** Tuning key  
**Colours** B-BK = Blue Shell/Black Hardware  
 R-BK = Red Shell/Black Hardware

## 3. BONGO STAND

The NINO® Bongo Stand has been developed especially for kids and their height in order to offer them a safe and comfortable playing position. It can be tilted in a 90° angle and height adjusted from 31" up to 45" so children can play standing up or sitting down. The NINO® Bongo Stand is also suitable for many other common bongo models.



**NINO20**

*The latch of the NINO Bongo Stand holds the bongo absolutely stable*

**Material** Chrome plated steel  
**Features** Fully height adjustable from 31" to 45"  
 90° angle adjustable  
 Tripod stand with rubber feet  
 Suitable for other common bongo models

## 4. NINO® BONGO BAG

The NINO® Bongo Bag is designed to supply reliable protection while transporting the instrument.

**MNBB**



4.

**Material** Padded nylon  
**Features** Padded shoulder strap  
 Carrying grip  
 Reinforced bottom

*Reinforced bottom*



# Cajons

**Sizes** Length 9.5" (24 cm)  
Height 13" (33 cm)  
Depth 10" (25.4 cm)  
Weight 5.5 lbs (2.500 gr)

**Materials** Frontplate: Makah-Burl  
Resonating Body: Rubber Wood  
(*Hevea brasiliensis* Muell.-Arg.)

**Features** Adjustable sizzle effect  
Anti-slip sitting surface  
Adjustable top corners

**Includes** Allen wrench

Adjustable sizzle effect

Anti-slip sitting surface

Adjustable top corners

Makah-Burl

Heavy duty rubber feet for a solid base

Internal snare wires



NIN0524

## 1. CAJON

The NINO® Cajon delivers the classic sound and due to its smaller dimension, it is especially suitable for a children. It is made from high quality materials ensuring long lasting life for this delightful instrument. Not just for children, professional players may find the NINO® Cajon interesting, as they add a different yet authentic Cajon sound to their arsenal of instruments.

## 2. NINO® DESIGNER SERIES CAJON - DEEP SEA

The NINO® Deep Sea Designer Series Cajon is a full sounding cajon decorated with a collection of friendly fish. It's an inviting way to get started with music!

## 3. BONGO CAJON

The NINO® Bongo Cajon is a great sounding cajon in a size suitable for children. The playing surface is divided into two sections, for high and low pitches, just like traditional bongo drums. It can be held between the knees, or set on the floor.

## 4. NINO® TRAPEZE CAJON

This new NINO® Cajon comes in a special trapeze shape for more comfort when playing. The internal snare wires provide a sensitive off of the Rubber Wood front plate.

## 5. NINO® CAJON BAG

The NINO® Cajon Bag is designed to supply reliable protection while transporting the instrument.



NIN0524DS

2.

**Material** Eco-friendly medium density fiberboard with appliqué graphics

**Feature** Internal snare wires  
Anti-slip sitting surface  
Adjustable top corners

**Colour** DS = Deep Sea

**Finish** Matte

Eco-friendly medium density fiberboard with appliqué graphics

NEW!

Trapeze shape!!

3.



NIN031

**Sizes** 12" x 5.5" x 5"

**Material** Rubber Wood  
(*Hevea brasiliensis* Muell.-Arg.)

**Feature** High- and low pitch playing surface

4.



NIN0527

**Sizes** Length 9.5" (24 cm)  
Height 13" (33 cm)  
Depth 10" (25.4 cm)

**Material** Rubber Wood  
(*Hevea brasiliensis* Muell.-Arg.)

**Features** Trapeze shape  
Internal snare wires  
Anti-slip sitting surface  
Adjustable top corners

Trapeze shape for more comfort!!

Carrying grip

5.



MNCJB

**Material** Padded nylon

**Features** Padded shoulder strap  
Carrying grip

Bongos, Cajons

# Frame Drums

## 1. TUNABLE NINO® HAND DRUMS WITH GOAT HEAD

The new NINO® Tunable Hand Drums are a great sounding drum in a kid-friendly form with a natural goat skin head. The head is tuned with external lugs, which are polished to remove sharp edges and plated for dependability and style.



Sizes 10", 12"  
 Materials Wooden frame  
 Hand selected goat head  
 Features Countersunk bolt lugs  
 Chrome plated hardware  
 Replaceable hand selected goat head  
 Includes Tuning key

## 2. TUNABLE NINO® HAND DRUMS WITH TRUE FEEL SYNTHETIC HEAD

These new NINO® Tunable Hand Drums feature our replaceable True Feel synthetic head for special durability and great feeling.



Sizes 10", 12"  
 Materials Wooden frame  
 True Feel synthetic head  
 Features Countersunk bolt lugs  
 Chrome plated hardware  
 Replaceable True Feel synthetic head  
 Includes Tuning key

## 3. NINO® HAND DRUMS WITH HANDLE

These NINO® Hand Drums come with a synthetic head and feature an ergonomically shaped wooden handle for playing comfort.



Sizes 10"  
 12"  
 Materials Plastic head  
 Wooden frame and handle  
 Feature Ergonomically shaped wooden handle





1.

Synthetic head  
firmly attached



Sizes 10", 12", 14"  
Materials Plastic head  
Wooden frame

### 1. WOOD HAND DRUMS

The NINO® Wood Hand Drums are equipped with synthetic heads that are firmly attached on a scalloped wooden frame. These nice sounding drums are light in weight and a proper instrument for children in kindergartens.

### 2. FRAME DRUMS

These NINO® Frame Drums are traditionally equipped with buffalo skin heads and come with a wooden beater. With their warm tone they can be used in various musical occasions.

2.



Sizes NIN0553 = 12 1/2"  
NIN0554 = 15"  
Material Buffalo skin heads  
Feature Velcro strap  
Includes Wooden beater

### 3. SEA DRUMS

The NINO® Sea Drum has hundreds of tiny metal balls enclosed between two clear mylar heads. By holding the drum horizontally and gently rolling it, you create the sounds of the ocean surf.



Sizes 10"  
12"  
14"  
Materials Rubber Wood  
(*Hevea brasiliensis* Muell.-Arg.)  
Two clear synthetic heads  
Feature Soothing sounds

NEW!

3.

NEW!



Soothing sounds

Frame Drums

WOOD HAND DRUMS  
FRAME DRUMS, SEA DRUMS

# Hand Percussion

## 1. WOOD TAMBOURINES

The NINO® Wood Tambourines feature a sturdy wooden frame along with a nice sparkling sound. They are available in a one row construction with 8 nickelsilver plated steel jingle pairs, or as a two row model with 16 nickelsilver plated steel jingle pairs.



1. **NIN015** **NIN014**

**Size** 10" diameter  
**Materials** Jingles: Nickelsilver plated steel  
 Wooden frame  
**Feature** 1 or 2 row versions available

## 2. RACKET TAMBOURINE

The NINO® Racket Tambourine features a sturdy rattan frame along with a nice sparkling sound. It is available as a one row construction with 9 aluminum jingle pairs. An ergonomically shaped handle makes it perfect for children hands.



2. **NIN0518**

**Materials** Frame: Rattan  
 Jingles: Aluminum  
**Features** Ergonomically shaped and padded handle

## 3. HEADED WOOD TAMBOURINES

With nickelsilver plated steel jingles and plastic heads firmly attached to the tambourine, this instrument delivers a subtle and gentle tone.



3. **NIN025**

**Size** 10" diameter  
**Materials** Jingles: Nickelsilver plated steel  
 Plastic heads  
 Wooden frame  
**Feature** 1 or 2 row versions available

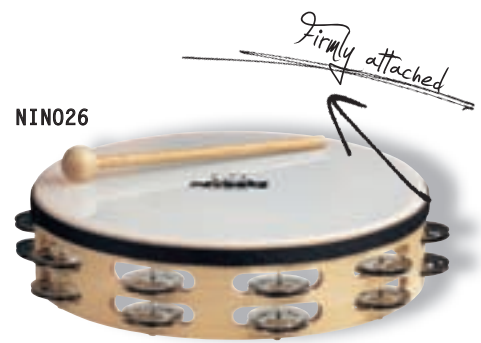

**NIN026**

## 4. A-GO-GO BELL

The NINO® A-Go-Go Bell is perfectly sized for children. It is handmade from high quality steel and produces a loud bell sound.



4. **NIN0505**

**Material** Black powder coated steel

## 5. TRIANGLES

NINO® Percussion offers three tonally matched triangles. Each have a strong sound with a long sustain.

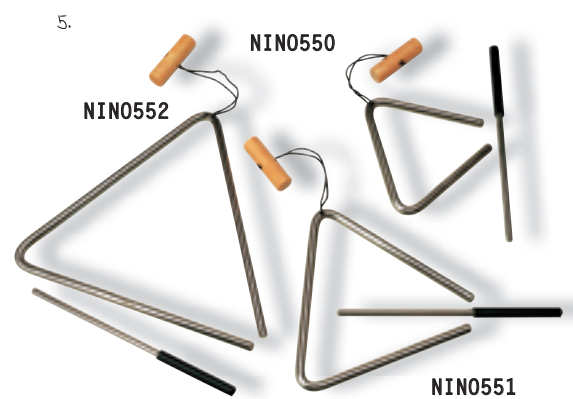

5. **NIN0550**  
**NIN0552** **NIN0551**

**Sizes** 4"  
 6"  
 8"  
**Material** Steel  
**Feature** Wooden holder with braided nylon strap  
**Includes** Metal beater with rubber padded grip

## 6. CABASAS

The NINO® Cabasas are made from a wooden cylinder covered with a rippled metal plate, which is surrounded by a net of metal beads. Holding the handle with one hand and scratching the metal beads with the other hand on the metal plate creates the classic cabasa sound. The smaller 2" model was especially designed for a child's hand.



6. **NIN0701** **NIN0702**

**Sizes** Small  
 Medium  
**Material** Steel chain and cylinder  
**Feature** Ergonomically shaped wooden handle  
*Fine sizzle sound*

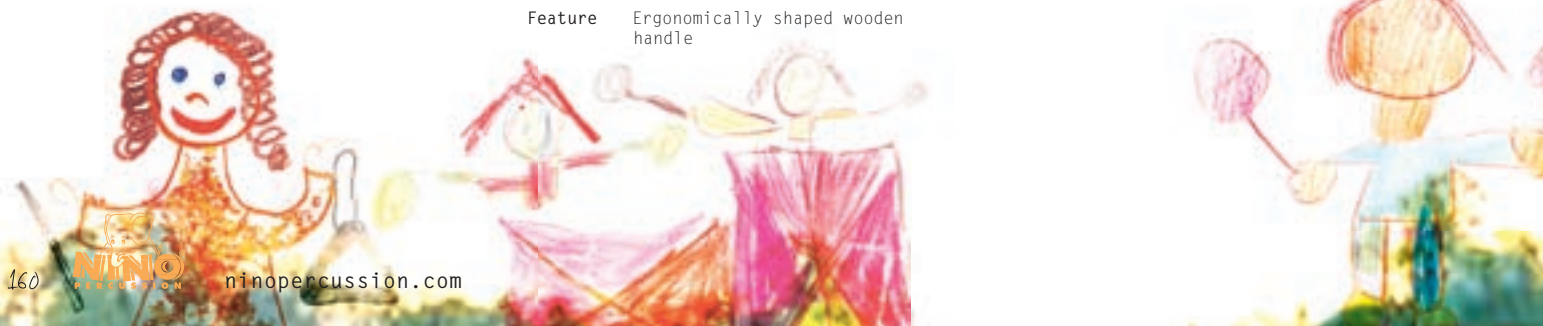



Size 12 bars  
Material Silver anodized aluminum alloy



Sizes Small  
Medium  
Large  
3 rows  
Material Silver anodized aluminum alloy  
Includes Wooden beater



## 7. CHIMES

The NINO® Chimes can be mounted on a cymbal stand, or held by the wooden frame. The 12 bars of the NINO® Chimes are made from a premium aluminum alloy and create a very full and rich sound.



Size 12 bars  
Material Silver anodized aluminum alloy



Sizes 7"/17.5 cm  
8"/20.0 cm  
Materials Bronze, brass, or nickel silver  
Includes Leather straps

## 8. ENERGY CHIMES

These NINO® instruments have a very cutting "ping" sound. The free floating bars create a very long sustain. NINO® offers three different pitched Energy Chimes, as well as a model with three bars.

## 9. HAND CHIMES

With bars made from a silver anodized aluminum alloy, the NINO® Hand Chimes produce a full and rich sound.

## 10. CYMBAL PAIRS

NINO® Cymbal Pairs are made in Germany from premium alloys. Different sizes are available in bronze, brass, or nickel silver. All cymbal pairs are tonally matched and are equipped with a leather strap.



Sizes 12"/30.5 cm  
14"/35.5 cm  
Material Nickel silver  
Includes Leather strap

## 11. CYMBALS

These excellent sounding NINO® Cymbals are made in Germany. They are a high quality product and perfect for music education.



# Hand Percussion

1.

**NIN013BK**



**NIN013R**

**NIN013Y**

**Materials** Jingles: Nickelsilver plated steel  
Frame: ABS

**Features** Ergonomically shaped handle  
New sound ideas

**Colours** BK = Black  
R = Red  
Y = Yellow

## 1. JINGLE STICKS

The NINO® Jingle Sticks feature six pairs of nickelsilver plated jingles firmly mounted on a plastic frame with a handle. The jingle stick can be played like a tambourine, or like a drumstick on a conga, bongo, or djembe. New and interesting sounds can be achieved with this instrument.

## 2. PLASTIC MARACAS

The NINO® Plastic Maracas are known for their stability, versatility, and strong, projecting sound.

## 3. MINI GUIROS

The NINO® Mini Guiros are made from high quality material. The sound is achieved by scratching the different surfaces of the guiro.

2.

**NIN0582R**

**NIN0582GR**



**NIN0582Y**



**Material** Plastic  
**Features** Ergonomically shaped handle  
Sold as pairs  
**Colours** GR = Green  
R = Red  
Y = Yellow

3.

**NIN0581BK**



**NIN0581R**



**Size** Mini  
**Includes** Wooden scraper  
**Colours** BK = Black  
R = Red



4.

**NINO566**



**Sizes** Small  
Medium

**Material** Rubber Wood  
(*Hevea brasiliensis* Muell.-Arg.)

**Features** Ergonomically shaped handle  
Sold as pairs

**NINO565**



5.

**NINO569R**



**Size** 6"

**Material** Plastic

**Features** Ergonomically shaped handle  
Sold as pairs

**Colour** R = Red

**4. WOOD EGG MARACAS**

Maracas are used for any style of music and are one of the most popular rhythm instruments worldwide. The NINO® Wood Egg Maracas have a nice warm sound and come with an ergonomically shaped handle.

**5. PLASTIC EGG MARACAS**

The NINO® Egg Maracas are made from a special plastic material. They have a very clear and pronounced sound and are perfect maracas for children.

**6. WOOD MARACAS**

The NINO® Wood Maracas sound very focused and have more attack.

**7. RAWHIDE MARACAS**

NINO® Rawhide Maracas are entirely hand made and have a warm and mellow sound.

**8. RAWHIDE EGG SHAKER**

The NINO® Rawhide Egg Shaker is entirely hand made and has a warm and mellow sound.

6.

**NINO7**



**Sizes** Small  
Medium

**Material** Rubber Wood  
(*Hevea brasiliensis* Muell.-Arg.)

**Features** Ergonomically shaped handle  
Sold as pairs

**NINO8**



7.

**NINO10**



**Size** Small

**Material** Natural rawhide

**Features** Mellow sound  
Ergonomically shaped wood handle  
Sold as pairs

8.

**NINO11**



**Material** Natural rawhide



# Hand Percussion

1.

**NIN0513GR**



**NIN0514GR**



**NIN0515GR**



**NIN0516GR**



**Sizes** Small  
Medium  
Large  
X-large

**Material** Wood

**Feature** Creates original "ribbit" sound

**Includes** Wooden scratcher

**Colour** GR = Green

## 1. WOOD FROGS

The NINO® Wood Frogs have gained an enormous popularity over the last few years. Children especially love the authentic "ribbit" sound which is created by scratching the wooden beater on the frog's back. Great fun for kids and adults.

## 2. WOOD SHAKERS

Toddlers especially love these little rhythm instruments. NINO® Natural Wood Shakers have different fillings. A cylindrical shaped shaker is available in two different sizes, as well as a square, and a triangular shaped shaker assortment.

## 3. WOOD ANIMALS

The NINO® Wood Animals are great sounding miniature imitations of a grasshopper, snail, turtle and pig. Scratching the wooden beater on the surface of the instruments creates a nice guiro-like sound. Great fun for kids and adults.

## 4. WOOD EGG SHAKERS

NINO® Wood Egg Shakers are very handy because of their shape. They also have a great sound with various pitches depending on their size.

2.

**NIN01**



**NIN02**



**NIN0507-MC**



**Shapes** NIN01 = Cylindrical, small  
NIN02 = Cylindrical, large  
NIN0507-MC = Square, 3 pcs. set  
NIN0508-MC = Triangular, 3 pcs. set

**Material** Rubber Wood  
(*Hevea brasiliensis* Muell.-Arg.)

**Feature** Different sounding fillings

**Colour** MC = Multi color

**NIN0508-MC**



3.

**NIN0537**



**NIN0539**



**NIN0541**



**NIN0538**

**Material** Wood

**Feature** Creates guiro-like sounds

4.

**NIN0564**



**NIN0563**



**NIN0562**



**Sizes** Small  
Medium  
Large

**Material** Rubber Wood  
(*Hevea brasiliensis* Muell.-Arg.)

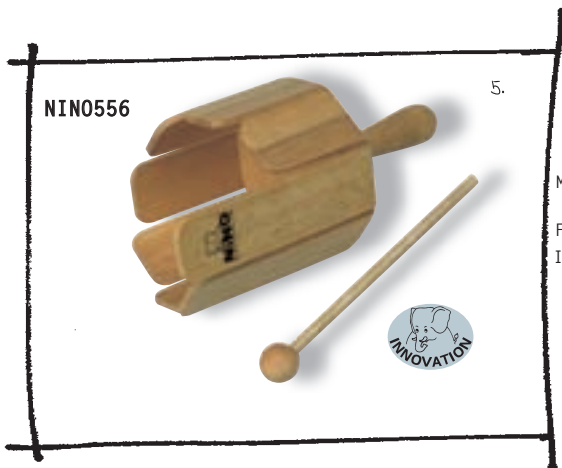

NINO556

5.

**Material** Rubber Wood  
(*Hevea brasiliensis* Muell.-Arg.)  
**Feature** Ergonomically shaped handle  
**Includes** Wooden beater



#### 5. WOOD STIRRING DRUM

The eight wooden tongues produce different pitches when they are struck separately, like playing a xylophone. By stirring in the drum with the included beater a scale can be played.

6. NINO557

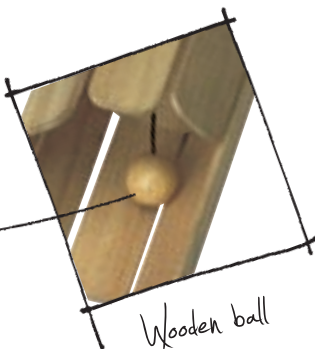
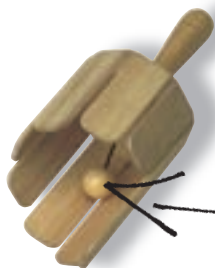

**Material** Rubber Wood  
(*Hevea brasiliensis* Muell.-Arg.)  
**Feature** Ergonomically shaped handle

#### 6. WOOD BALL STIRRING DRUM

The NINO® Wood Ball Stirring Drum is a further development of the familiar stirring drum. When playing the drum, a wooden ball fastened to a nylon string strikes the tonally matched wooden tongues and produces a harmonic sound.

#### 7. WOOD HAND CASTANETS

The NINO® Wood Hand Castanets are a fun way to make rhythm. Solid wood construction assures good sound and safe play.

NINO585



**Material** Rubber Wood  
(*Hevea brasiliensis* Muell.-Arg.)  
**Feature** Attractive shape



*Hand Percussion*

# Hand Percussion

## 1. WOOD CLAVES

Claves are an essential instrument in Latin music and shouldn't be missing from any percussion set up. The NINO® Wood Claves are available as regular sized models. A second pair was especially designed to fit a child's hand size.

## 2. WOOD BLOCKS

The Wood Block is probably one of the oldest rhythm instruments and should be part of any percussion group. The NINO® Wood Blocks have an impressive sound and are available in two sizes.

## 3. WOOD A-GO-GO'S

The NINO® Wood A-go-go's are played with a wooden beater and produce a powerful sound. They can also be scratched like a guiro. These two playing styles leave room for creativity.

## 4. WOOD TONE BLOCK

The NINO® Wood Tone Block has two tonally matched resonant chambers in the solid wooden body.

## 5. ORIENTAL WOOD TONE BLOCK

The NINO® Oriental Wood Tone Block produces a high pitched and open sound.

1.

NIN0502



NIN0574

Sizes	Small Regular
Material	Rubber Wood ( <i>Hevea brasiliensis</i> Muell.-Arg.)
Feature	Sold as pairs

2.

NIN022

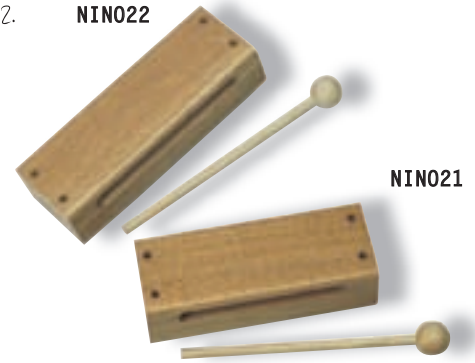

NIN021

Sizes	Medium Large
Material	Rubber Wood ( <i>Hevea brasiliensis</i> Muell.-Arg.)
Includes	Wooden beater

3.

NIN0561

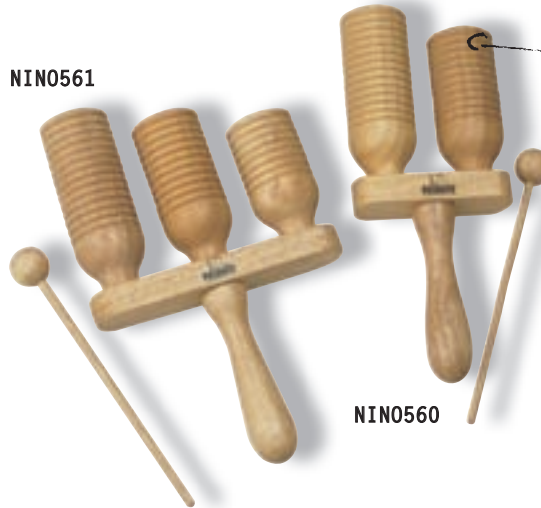

Sizes	2 rows 3 rows
Material	Rubber Wood ( <i>Hevea brasiliensis</i> Muell.-Arg.)
Features	Different playing options Ergonomically shaped handle
Includes	Wooden beater

NIN0560

4.

NIN0570



NIN0571

*Tonally matched*

5.



NIN0572

Material	Rubber Wood ( <i>Hevea brasiliensis</i> Muell.-Arg.)
Feature	Ergonomically shaped handle
Includes	Wooden beater







**NINO555**

**Material** Rubber Wood  
(*Hevea brasiliensis* Muell.-Arg.)  
**Includes** Wooden striker



**NINO519**

**Material** Rubber Wood  
(*Hevea brasiliensis* Muell.-Arg.)

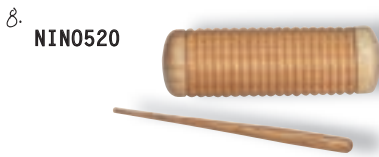

**NINO520**

**Material** Rubber Wood  
(*Hevea brasiliensis* Muell.-Arg.)  
**Feature** Additional shaker sound  
**Includes** Wooden striker



**NINO521**

**NINO522**

**Sizes** Small  
Medium  
**Materials** Rattan with coconut bottom



**NINO501**

**Materials** Rattan with natural skin hide bottom



**NINO503**

**Materials** Rattan with natural skin hide bottom

**6. WOOD GUIRO**

The guiro is an instrument which plays a very important part in any percussion set up. Striking the tonal grooves of the NINO® Wood Guiro creates many different sounds.

**7. WOODPECKER**

The NINO® Woodpecker creates an amazingly realistic “woodpecker” sound. It’s a great effect instrument which is also interesting for professional players who look to increase their sound arsenal.

**8. WOOD GUIRO SHAKER**

The NINO® Wood Guiro Shaker is equipped with a filling and combines a shaker as well as a guiro sound in one instrument.

**9. GANZA SHAKERS**

The NINO® Ganza Shakers produce a voluminous sound due to their size.

**10. CAXIXI**

The NINO® Caxixi produces a clear and cutting sound.

**11. DOUBLE SHAKER**

The NINO® Double Shaker produces a clear and cutting sound with enhanced volume.



*Hand Percussion*

CLAVES, BLOCKS, A-GO-GO'S, TONE BLOCK, ORIENTAL TONE BLOCK  
GUIRO, WOODPECKER, GUIRO SHAKER, GANZA SHAKERS, CAXIXI, DOUBLE SHAKER

# Shakers

## BOTANY SHAKERS

The NINO® Botany Shakers are made from a high quality plastic material filled with a specially nice sounding substance. These fruit and vegetable imitations look amazingly real and create a great variety of sounds. NINO® Botany Shakers have been tested for saliva resistance.

- 1. "FRUIT" ASSORTMENT  
4 pcs.
- 2. "VEGETABLE" ASSORTMENT  
4 pcs.
- 3. BOTANY SHAKER ASSORTMENT  
36 pcs.

### 1. NINOSSET100

Material Plastic  
Feature Botany Shaker Assortment, 4 pcs. "fruit"

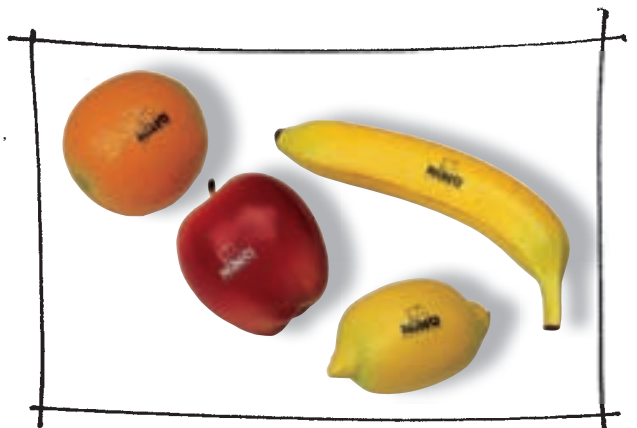

### 2. NINOSSET101

Material Plastic  
Feature Botany Shaker Assortment, 4 pcs. "vegetable"



### 3. VE36-NIN0536

Material Plastic  
Feature Botany Shaker Assortment, 36 pcs. incl. 2 baskets of each 18 pcs.



4.

NINO540LB



NINO540LR

NINO540LGR



NINO540LBK



NINO540LY

Material Plastic  
 Colours B = Blue  
 BK = Black  
 GR = Green  
 R = Red  
 Y = Yellow

#### 4. EGG SHAKERS

NINO® Egg Shakers are vital to every percussion collection. They have an extremely pronounced and crystal clear sound.

5. ASSORTMENT, 4 pcs.

6. ASSORTMENT, 80 pcs.

#### 7. BALL SHAKER

The two shakers are firmly attached to each other with a strong cord. By tightly holding one ball and rhythmically swinging the other one, many sounds can be achieved.

5.



NINOSET540

6.

VE80-NINO540



Material Plastic  
 Sets Egg Shaker Set 4 pcs.  
 Egg Shaker Set 80 pcs. including elephant shaped basket

7.

NINO509



Material Plastic  
 Feature Attractive Harlekin® design



# Nino® Sets

NINO® instruments have been designed to meet the demands of early childhood education and are perfectly suitable for the use in kindergartens, schools, music therapy and musical activities in the family. Available are two different NINO® Percussion collections which come in a durable nylon Harlekin® design bag. It's the perfect activity for small groups of up to 8 children.



## 1. NINOSET1

### Contents:

- 1 x ABS Hand Drum 6"
- 1 x Wooden Beater
- 1 x Wood Shaker, large
- 1 x Skin Maracas pair, small
- 1 x Jingle Stick
- 1 x Harlekin® bag



## 2. NINOSET4

### Contents:

- 1 x Wood Guiro
- 1 x Caxixi
- 1 x Wood Claves pair, small
- 1 x Triangle, 4"
- 1 x Egg Shaker
- 1 x Egg Shaker, small
- 1 x Botany Shaker, Banana
- 1 x Botany Shaker, Apple
- 1 x Harlekin® bag

## 3. MUSIC BAGS

Handy bags made from durable nylon are always useful. These NINO® Music Bags are available in red and the Harlekin® design. Many separate compartments make them ideal for all kind of activities.



Material Nylon  
 Feature Many compartments  
 Colours HK = Harlekin®  
 R = Red

# Nino® Rhythm Sets

These two NINO® Rhythm Sets include 12 or 15 individual instruments. They are perfect for use in kindergarten, schools, or percussion groups. These collections of different instruments are the ideal way to explore the complete NINO® world of percussion and rhythm.

## 1. RHYTHM ASSORTMENT, 12 pcs.



**NINOSSET012**

## 1. RHYTHM ASSORTMENT, 12 pcs.

### Contents:

- 1 x ABS Hand Drum 12"
- 1 x ABS Tambourine 10"
- 1 x ABS Hand Drum 8"
- 1 x ABS Hand Drum 6"
- 1 x Skin Maracas pair, medium
- 1 x Wood Block, large
- 1 x Skin Egg Shaker
- 1 x Jingle Stick, yellow
- 1 x Jingle Stick, red
- 1 x Wood Tambourine, 10"
- 1 x Wood Shaker, small

## 2. RHYTHM ASSORTMENT, 15 pcs.

### Contents:

- 1 x Wood Guiro
- 1 x Triangle, 6"
- 1 x Plastic Egg Maracas pair, red
- 1 x Mini Guiro
- 1 x Egg Shaker
- 1 x Racket Tambourine
- 1 x Wood Claves pair, small
- 1 x Energy Chimes, medium
- 1 x Wood A-Go-Go, 2 rows
- 1 x Double Shaker
- 1 x Wood Shaker Assortment 3 pcs., triangular
- 1 x Botany Shaker, Banana
- 1 x Basket

## 2. RHYTHM ASSORTMENT, 15 pcs.



**NINOSSET515**

# ABS Drums

The colourful NINO® ABS Drums are not only durable, they also have a powerful sound. Shells made from ABS plastic and synthetic heads guarantee great stability and a long life. With their low weight of about two pounds and their outstanding workmanship.

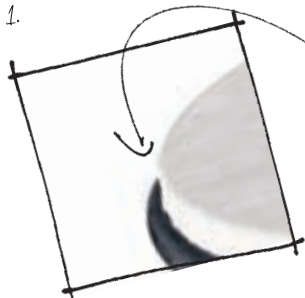

The drums come pretuned and ready to play right out of the box

- Size 8"
- Material ABS plastic
- Feature Synthetic heads
- Includes Nylon strap
- Colours B = Blue  
G/Y = Green/Yellow  
R/BK = Red/Black  
R = Red



NINO18R/BK

NINO18R

NINO18B

NINO18G/Y

## 1. ABS DJEMBES

The multi-coloured NINO® ABS Djembes come pretuned and ready to play right out of the box.

2.



NINO19G/Y



NINO19B

## 2. ABS BONGOS

The NINO® ABS Bongos are light weight and are perfect instruments for children in kindergarten or elementary school.



NINO19R/BK



NINO19R

- Sizes 6 1/2" & 7 1/2"
- Material ABS plastic
- Feature Synthetic heads
- Colours B = Blue  
G/Y = Green/Yellow  
R/BK = Red/Black  
R = Red



3.



NINO6BK NINO6Y NINO6GR NINO6B NINO6R



NINO5BK NINO5Y NINO5GR NINO5B NINO5R



NINO45BK NINO45Y NINO45GR NINO45B NINO45R



NINO4BK NINO4Y NINO4GR NINO4B NINO4R

Sizes	NINO4 = 6" NINO45 = 8" NINO5 = 10" NINO6 = 12"	Includes	Wooden beater
Material	ABS plastic	Colours	B = Blue BK = Black GR = Green R = Red Y = Yellow
Feature	Synthetic heads		



The drums come pretuned and ready to play right out of the box !!!

4.



NINO24BK NINO24R NINO24B NINO24GR NINO24Y

Size	10"	Colours	B = Blue BK = Black GR = Green R = Red Y = Yellow
Materials	ABS plastic with nickelsilver jingles		
Feature	Synthetic heads		
Includes	Wooden beater		

### 3. ABS HAND DRUMS

The multi-coloured NINO® ABS Hand Drums offer more than just tonal variety. The unbreakable shells and durable synthetic heads ensure years of trouble-free use.

### 4. ABS TAMBOURINES

The NINO® ABS Tambourines offer enhanced sound options due to attached jingle pairs.



ABS Drums

# Djembes

1.



NINO-ADJ2-XXS

NINO-ADJ2-S

NINO-ADJ2-XS

**Material** Mahogany Wood  
**Features** Carved from one solid piece of plantation grown Mahogany Wood  
 Hand selected goat heads  
 High quality PP nylon ropes  
 Hand carved shells  
**Colour** Brown

## ORIGINAL AFRICAN STYLE ROPE TUNED WOOD DJEMBES

The NINO® Original African Style Rope Tuned Wood Djembes are carved from one solid piece of plantation grown Mahogany Wood. These high quality instruments are crafted with great attention to detail and provide an outstanding sound.

1. WATER RHYTHM SERIES
2. EARTH RHYTHM SERIES
3. MOON RHYTHM SERIES

Sizes	Diameter	Tall
XXS = 4 1/2"	4 1/4"-4 3/4"	8"
XS = 7"	6 1/4"-8 1/4"	11 3/4"
S = 8"	7"-8 1/2"	15 3/4"

PP rope	Thickness	Runners
XXS	3 mm	10
XS	3 mm	20
S	4 mm	20

2.

Pre-stretched high quality PP nylon rope



NINO-ADJ3-XXS

NINO-ADJ3-S

NINO-ADJ3-XS

**Material** Mahogany Wood  
**Features** Carved from one solid piece of plantation grown Mahogany Wood  
 Hand selected goat heads  
 High quality PP nylon ropes  
 Hand carved shells  
**Colour** Brown/Black

Carved design



3.



NINO-ADJ4-XXS

NINO-ADJ4-S

NINO-ADJ4-XS

**Material** Mahogany Wood  
**Features** Carved from one solid piece of plantation grown Mahogany Wood  
 Hand selected goat heads  
 High quality PP nylon ropes  
 Hand carved shells  
**Colour** Black

Carved from one solid piece of plantation grown Mahogany Wood





Size 10"  
21" tall

Material Rubber Wood  
(*Hevea brasiliensis* Muell.-Arg.)

Features Hand selected goat head  
Rounded rim for playing comfort  
Black powder coated hardware  
Floatune Tuning System

Includes Tuning key

Colour NT = Natural



NINO23NT

4. WOOD DJEMBE

The Djembe is the most popular African drum. Even first time players are quickly able to draw different tones from this great instrument. The NINO® Wood Djembe has a diameter of 10" and a height of 21" and is the perfect drum for children in kindergarten or elementary school.

5. NINO® DJEMBE BAG

The NINO® Djembe Bag is designed to supply reliable protection while transporting the instrument. It holds djembes up to 10" diameter.

6. NINO® DESIGNER SERIES DJEMBE

The NINO® Deep Sea Designer Series Djembe is easy tunable drum in a very attractive design.



MNDJB

Size Up to 10"

Material Padded nylon

Features External pocket  
Shoulder strap  
Carrying grip

5.



NINO23DS

Size 10"  
21" tall

Material Rubber Wood with appliqué graphics  
(*Hevea brasiliensis* Muell.-Arg.)

Features Hand selected goat head  
Rounded rim for playing comfort  
Black powder coated hardware  
Floatune Tuning System

Includes Tuning key

Colour DS = Deep Sea



# Shake'n Play

The NINO® Shake'n Play is a sound-based memory game for two to four children ages three years and up, and fun for the entire family. Sixteen identical shakers make eight matched pairs. The object of the game is to find the pairs by remembering the sounds and positions on the board. Shake'n Play is a good development game and certified child-proof by the LGA.



Images on bottom ensure correct match

**FUN FOR THE ENTIRE FAMILY**

NINO526

Certified childproof by the LGA



## SHAKE'n PLAY

game guide

### Who can find the most pairs?

Type of game: Memory game  
 Contents: 16 shakers (8 pairs)  
 1 game board  
 1 game guide

### Advice for parents

To begin, it is often helpful for young first-time players to listen carefully to all the sounds first, in order to identify the different tones.

### Setting up

Before the game begins the 16 shakers are shuffled and placed, with the sticker face downwards on the game board.

### Aim of the game

Every player tries to collect as many pairs as possible.

### How to play

The youngest child begins by taking a shaker and shaking it so all players can hear the sound. Then a second shaker is selected and shaken and the two tones compared. If a correctly matching pair of shakers is found then the player may keep the shakers and may try their luck again. If the tones of the two selected shakers are different then the player replaces the shakers on the game board and the next player continues. To ensure that correct shaker pairs are found, each respective pair is marked on the underside with an instrument sticker. Any confusion is therefore impossible.

### End of game

The game ends when there are no more shakers left on the game board. The winner is the player with the most shakers.

- Materials** Plastic shakers  
 Base out of Rubber Wood  
 (Hevea brasiliensis Muell.-Arg.)
- Includes** 16 shakers (8 pairs)  
 Game guide (in 8 languages)  
 Wooden base
- Colour** Orange



Game guide (in 8 languages)



# Glockenspiels

1.

Removable colour-coded metal keys

Keys tuned to a scale of c3 d3 e3 f3 g3 a3 b3 c4

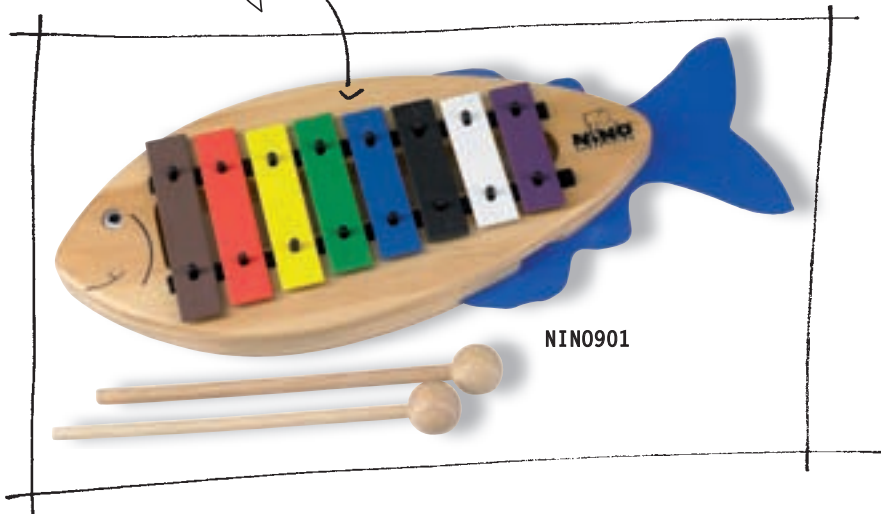

- Materials** Body made out of Pine Wood  
Removable colour-coded metal keys
- Includes** Two wooden mallets  
Songbook
- Finish** Matte



## 1. NINO® GLOCKENSPIEL

The NINO® Glockenspiel is a child-friendly way to start out with music. The jolly fish has colourful keys tuned to a scale of c3 d3 e3 f3 g3 a3 b3 c4. The keys may be removed for simplicity and later replaced as your child develops confidence. All corners are contained inside the rounded profile of the wooden body. The googly eye and flapping blue tail make the "Fish" Glockenspiel a charming and entertaining character!

## 2. NINO® C MAJOR SCALE GLOCKENSPIEL

The NINO® Glockenspiel is a compact, child-friendly instrument that is great for learning the musical fundamentals. The NINO® Glockenspiel has a scale from c3 to f4. It also has a b-flat3 and an f-sharp3 key mounted on the side, as supplemental notes that complete the C major scale. The keys may be removed for simplicity and later replaced as the young player develops confidence. Mallets are included.

2.

The keys may be removed for simplicity and later replaced as the young player develops confidence!



Additional b-flat3 and f-sharp3 keys as supplemental notes

- Materials** Wooden body  
Removable steel keys
- Tones** c3, d3, e3, f-sharp3, g3, a3, b-flat3, b3, c4, d4, e4, f4
- Includes** Two wooden mallets
- Finish** Matte

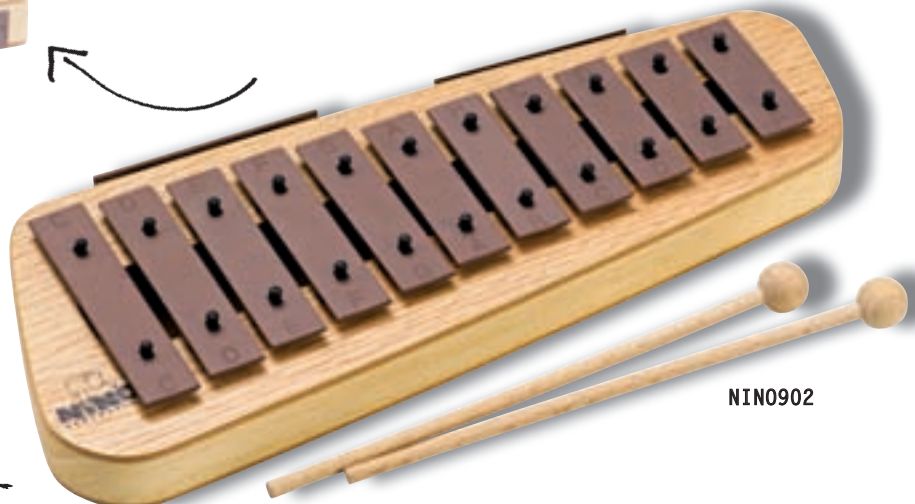

new!

# Merchandise

Support your favourite percussion brand with the official MEINL swag. A selection of exclusive items made from the highest quality materials.

1. T-SHIRT

Sizes S, M, L, XL, XXL  
 Colour Black  
 Front MEINL logo, small  
 Back MEINL logo, big



M59

1.

2. LONG SLEEVE  
 W. RED ARMS

3. WORK SHIRT

4. POLO SHIRT

5. SKULL LONG SLEEVE

Front



M74

2.

Back

Sizes M, L, XL  
 Colour Black/Red  
 Front MEINL logo, small  
 Back MEINL logo, big

**NEW!**

3.



M78

Sizes S, M, L, XL  
 Colour Black  
 Front MEINL logo, embroidered

Front only



M25

4.

Sizes M, L, XL, XXL  
 Colour Black  
 Front MEINL logo, small

5.



M86

**NEW!**

Sizes S, M, L, XL  
 Colour Black  
 Front Skull



Back

Let's get branded ;-)

6. TRAINING JACKET

7. T-SHIRT

8. HOOD SHIRT W. ZIPPER

9. SKULL T-SHIRT

6. Front



M73

Sizes M, L, XL, XXL  
 Colour Black  
 Front MEINL logo, small  
 Back MEINL logo, big

Back

7.

Front



M42

Sizes S, M, L, XL, XXL  
 Colour Black  
 Front MEINL logo, small  
 Back MEINL logo, big



8.

new!

9.

Front

Back



M85

Sizes S, M, L, XL  
 Colour Black  
 Front Skull



M48

Sizes S, M, L, XL, XXL  
 Colour Black  
 Front MEINL logo, small  
 Back MEINL logo, big

Merchandise

T-SHIRT, LONG SLEEVE W. RED ARMS, WORK SHIRT, POLO SHIRT, SKULL LONG SLEEVE TRAINING JACKET, T-SHIRT, HOOD SHIRT W. ZIPPER, SKULL T-SHIRT

# Merchandise

1. ARMY CAPS
2. SWEAT SHIRT
3. TRAINING JACKET
4. DRUM CIRCLE SHIRT
5. FACES OF PERCUSSION SHIRT
6. SOFTSHELL JACKET



Sizes S, M, L, XL, XXL  
 Colour Black  
 Front MEINL logo, small  
 Back MEINL logo, big



Sizes M, L, XL, XXL  
 Colour Black  
 Front MEINL logo, small  
 Back MEINL logo, big



Sizes S, M, L, XL, XXL  
 Colour Pistachio  
 Front Drum Circle Motive



Sizes S, M, L, XL, XXL  
 Colour White  
 Front Faces of Percussion 2009



Sizes M, L, XL, XXL  
 Colour Black  
 Front MEINL logo, embroidered

NEW!





7.

MBS30

MBS24

Sizes 24", 30"

- 7. BAR STOOL
- 8. BACKPACK
- 9. MOUSE PAD "CONGA HEAD"
- 10. TROLLEY
- 11. LANYARD



8.

MPBB



9.

M51



10.

**NEW!**

T-PBT-BK



11.

M35

*Merchandise*

# Spare Parts

Model No.	Size	Material						Features				SPARE PARTS						
		Hardwood	Aluminum	Premium Fiberglass	Rubber Wood	ABS	Steel	Counter sunk bolt heads	Replaceable synthetic heads	Replaceable goat heads	Height adjustable legs	Steel snare wires	Floatune Tuning System	Head	Rim	Lug	Bracket	Page
<b>Frame Drums</b>																		
<b>PANDEIROS</b>																		
PA10	10"					X		X	X				HEAD-44	RIM-33	LUG-24	BRACKET-19	16	
PA10ABS	10"					X	X	X				HEAD-48	RIM-33	LUG-24	BRACKET-19	17		
PA12	12"					X		X	X			HEAD-45	RIM-34	LUG-24	BRACKET-19	16		
<b>OTHER PARTS</b>												Tuning Key for Pandeiro						KEY-08

Model No.	Size	Material						Features				SPARE PARTS						
		Hardwood	Aluminum	Premium Fiberglass	Rubber Wood	ABS	Steel	Counter sunk bolt heads	Replaceable synthetic heads	Replaceable goat heads	Height adjustable legs	Steel snare wires	Floatune Tuning System	Head	Rim	Lug	Bracket	Page
<b>Samba</b>																		
<b>FLOATUNE TAMBORIMS</b>																		
TBR06	6"		X	X	X	X	X	X	X		X	HEAD-40	RIM-32	LUG-20			28	
<b>FIBERGLASS CUICA</b>																		
QW7	8"		X					X			X	HEAD-13	RIM-10	LUG-13			30	
<b>ALUMINUM CUICA</b>																		
QW6	6"		X					X				HEAD-57	RIM-44	LUG-35			30	
QW10	10"		X					X	X			HEAD-58	RIM-45	LUG-36			30	
<b>ALUMINUM CAIXAS</b>																		
CA12	12"		X					X	X		X	HEAD-51	RIM-42 (Top)	LUG-33			31	
CA14	14"		X					X	X		X	HEAD-52	RIM-43 (Top)	LUG-34			31	
<b>TRADITIONAL CAIXA</b>																		
CA12T	12"		X					X	X		X	HEAD-51	RIM-42 (Top)	LUG-41			31	
<b>ALUMINUM REPINQUES</b>																		
RE10	10"		X					X	X			HEAD-48	RIM-39 (Top)	LUG-29			32	
RE12	12"		X					X	X			HEAD-47	RIM-36 (Top)	LUG-28			32	
<b>WOOD REPINIQUE</b>																		
RE12	12"			X				X	X			HEAD-47	RIM-36	LUG-32			32	
<b>ALUMINUM SURDOS</b>																		
SU16	16"		X					X	X			HEAD-59	RIM-46 (Top)	LUG-37			33	
SU18	18"		X					X	X			HEAD-49	RIM-40 (Top)	LUG-30			33	
SU20	20"		X					X	X			HEAD-46	RIM-35 (Top)	LUG-27			33	
SU22	22"		X					X	X			HEAD-50	RIM-41 (Top)	LUG-31			33	
<b>STAND ALONE ALUMINUM SURDOS</b>																		
SU16-L	16"		X					X	X	X		HEAD-59	RIM-46 (Top)	LUG-37			33	
SU18-L	18"		X					X	X	X		HEAD-49	RIM-40 (Top)	LUG-30			33	
SU20-L	20"		X					X	X	X		HEAD-46	RIM-35 (Top)	LUG-27			33	
SU22-L	22"		X					X	X	X		HEAD-50	RIM-41 (Top)	LUG-31			33	
<b>WOOD SURDOS</b>																		
SU16	16"	X						X	X			HEAD-59	RIM-46 (Top)	LUG-37			34	
SU18	18"	X						X	X			HEAD-49	RIM-40 (Top)	LUG-30			34	
SU20	20"	X						X	X			HEAD-46	RIM-35 (Top)	LUG-27			34	
SU22	22"	X						X	X			HEAD-50	RIM-41 (Top)	LUG-31			34	
<b>STAND ALONE WOOD SURDOS</b>																		
SU16-L	16"	X						X	X	X		HEAD-59	RIM-46 (Top)	LUG-37			34	
SU18-L	18"	X						X	X	X		HEAD-49	RIM-40 (Top)	LUG-30			34	
SU20-L	20"	X						X	X	X		HEAD-46	RIM-35 (Top)	LUG-27			34	
SU22-L	22"	X						X	X	X		HEAD-50	RIM-41 (Top)	LUG-31			34	
<b>BAHIA ALUMINUM SURDOS</b>																		
SUB18	18"		X					X	X			HEAD-49	RIM-40 (Top)	LUG-38			35	
SUB20	20"		X					X	X			HEAD-46	RIM-35 (Top)	LUG-39			35	
SUB22	22"		X					X	X			HEAD-50	RIM-41 (Top)	LUG-40			35	
<b>BAHIA WOOD SURDOS</b>																		
SUB18	18"	X						X	X			HEAD-49	RIM-40 (Top)	LUG-38			35	
SUB20	20"	X						X	X			HEAD-46	RIM-35 (Top)	LUG-39			35	
SUB22	22"	X						X	X			HEAD-50	RIM-41 (Top)	LUG-40			35	
<b>OTHER PARTS</b>												A Go Go Bell Holder						STBAGH
Tuning Key for Caixa												KEY-09						
Tuning Key for Surdo and Repinique												KEY-10						
Nappa Heads for Surdo												HEAD-66 = 16" / HEAD-67 = 18" / HEAD-68 = 20" / HEAD-69 = 22"						34



Model No.	Size	Height	Material	Features	SPARE PARTS					
					Head	Rim	Lug	Bracket	Page	
<b>HEADLINER® SERIES WOOD CONGA SETS</b>										
HC512 (incl. basket stands)	11" + 12"	28"	✓			HHEAD11/HHEAD12C	HRIM11/HRIM12C	HCLUG	HCBRACKET-02	56/57
HC555 (incl. basket stands)	10" + 11"	28"	✓			HHEAD10/HHEAD11	HRIM10/HRIM11	HCLUG	HCBRACKET-02	54/55
<b>HEADLINER® DESIGNER SERIES CONGAS</b>										
HC10 (incl. basket stands)	10"	28"	✓			HHEAD10	HRIM10	HCLUG	HCBRACKET-02	58-61
HC11 (incl. basket stands)	11"	28"	✓			HHEAD11	HRIM11	HCLUG	HCBRACKET-02	58-61
HC12 (incl. basket stands)	12"	28"	✓			HHEAD12C	HRIM12C	HCLUG	HCBRACKET-02	58-61
<b>HEADLINER® FIBERGLASS SERIES CONGAS</b>										
HC10 (incl. basket stands)	10"	28"	✓			HHEAD10	HRIM10	HCLUG	HCBRACKET-02	62
HC11 (incl. basket stands)	11"	28"	✓			HHEAD11	HRIM11	HCLUG	HCBRACKET-02	62
HC12 (incl. basket stands)	12"	28"	✓			HHEAD12C	HRIM12C	HCLUG	HCBRACKET-02	62
<b>ARTIST SERIES, Luis Conte</b>										
LC11	11"	30"	✓	✓	✓	TS-B-52	TTR-28	LUG-03	BRACKET-20	63
LC1134	11 3/4"	30"	✓	✓	✓	TS-B-53	TTR-29	LUG-03	BRACKET-20	63
LC1212	12 1/2"	30"	✓	✓	✓	TS-B-54	TTR-30	LUG-03	BRACKET-20	63
<b>MARATHON® CLASSIC SERIES / DESIGNER SERIES</b>										
MCC11	11"	30"	✓	✓	✓	TS-B-38	SSR-25	LUG-03	BRACKET-15	64-69
MCC1134	11 3/4"	30"	✓	✓	✓	TS-B-39	SSR-26	LUG-03	BRACKET-15	64-69
MCC1212	12 1/2"	30"	✓	✓	✓	TS-B-40	SSR-27	LUG-03	BRACKET-15	64-69
<b>PROFESSIONAL SERIES</b>										
MP11	11"	30"	✓	✓	✓	TS-B-34	SSR-22	LUG-01	BRACKET-14	70/71
MP1134	11 3/4"	30"	✓	✓	✓	TS-B-35	SSR-23	LUG-01	BRACKET-14	70/71
MP1212	12 1/2"	30"	✓	✓	✓	TS-B-36	SSR-24	LUG-01	BRACKET-14	70/71
<b>FIBERCRAFT SERIES / DESIGNER SERIES</b>										
FC11	11"	30"	✓	✓	✓	TS-B-34	SSR-22	LUG-01	BRACKET-14	72/73
FC1134	11 3/4"	30"	✓	✓	✓	TS-B-35	SSR-23	LUG-01	BRACKET-14	72/73
FC1212	12 1/2"	30"	✓	✓	✓	TS-B-36	SSR-24	LUG-01	BRACKET-14	72/73
<b>FLOATUNE SERIES</b>										
FL10	10"	30"	✓	✓	✓	TS-B-01	SSR-06	LUG-01		74
FL11	11"	30"	✓	✓	✓	TS-B-03	SSR-07	LUG-01		74
FL12	12"	30"	✓	✓	✓	TS-B-15	SSR-12	LUG-01		74
FL13	13"	30"	✓	✓	✓	TS-B-21	SSR-15	LUG-01		74
<b>ARTIST SERIES, Mongo Santamaria</b>										
MSA11	11"	30"	✓	✓	✓	TS-B-07	SSR-08	LUG-02	BRACKET-16	75
MSA1134	11 3/4"	30"	✓	✓	✓	TS-B-11	SSR-10	LUG-02	BRACKET-16	75
MSA1212	12 1/2"	30"	✓	✓	✓	TS-B-17	SSR-13	LUG-02	BRACKET-16	75
<b>WOODCRAFT SERIES</b>										
WC11	11"	30"	✓	✓	✓	TS-B-44	TTR-23	LUG-01	BRACKET-14	76/77
WC1134	11 3/4"	30"	✓	✓	✓	TS-B-45	TTR-24	LUG-01	BRACKET-14	76/77
WC1212	12 1/2"	30"	✓	✓	✓	TS-B-46	TTR-25	LUG-01	BRACKET-14	76/77
<b>SPARE PARTS FOR STANDS</b>										
10" Basket for HC555						HSTAND10				54 / 55
10" Basket for Designer/Fiberglass Series						HSTAND10				58-62
11" Basket for HC555/HC512 and Designer/Fiberglass Series						HSTAND11				54-62
12" Basket for HC512 and Designer/Fiberglass Series						HSTAND12				56-62
Rubber Feet (set of 3 pcs.) for Steely-II Stand						STAND-35				78
Rubber Tops (set of 3 pcs.) for Steely-II Stand						STAND-21				78
Screw Set complete for Steely-II Stand, black						STAND-22				78
Screw Set complete for Steely-II Stand, chrome						STAND-23				78
Screw Set complete for Steely-II Stand, gold tone						STAND-24				78
Socket Screw (set of 2 pcs.) black						STAND-26				78
Socket Screw (set of 2 pcs.) chrome						STAND-27				78
Socket Screw (set of 2 pcs.) gold tone						STAND-28				78
<b>OTHER PARTS</b>										
Lug Oil						SPARE-09				
Conga Saver for 8mm Lugs (set of 6 pcs.)						CONGA-SAVER8				
Conga Saver for 10mm Lugs (set of 6 pcs.)						CONGA-SAVER10				
Tuning Key, 13mm + 14mm, L shaped, gold tone						KEY-01				
Tuning Key, 13mm + 14mm, L shaped, chrome						KEY-02				
Tuning Key, 14mm, chrome						KEY-03				
Tuning Key, 13mm, chrome						KEY-04				

# Spare Parts

				SPARE PARTS										
Model No.	Size	Material	Features	Head	Rim	Lug	Bracket	Page						
<h1>Bongos</h1>				Acrylic										
				ABS-Plastic										
				American White Ash										
				Rubber Wood										
				Premium Fiberglass										
				True Skin Cow Heads										
				True Skin Buffalo Heads										
				SSR-Rim										
				TTR-Rim										
				Free Ride System										
<b>HEADLINER® SERIES ABS BONGO / ACRYLIC BONGO</b>														
HB50	6 1/2"	XX						HHEAD6.5	RIM-NI3-65-BK	LUG-NIN03		82		
HB50	7 1/2"	XX						HHEAD7.5	RIM-NI3-75-BK	LUG-NIN03		82		
<b>HEADLINER® SERIES WOOD BONGOS / DESIGNER / FIBERGLASS SERIES</b>														
HB100	6 3/4"			XX	XX				HHEAD634W	HRIM634W	HBLUG		82/83	
HB100	8"			XX	XX				HHEAD8W	HRIM8W	HBLUG		82/83	
<b>FREE RIDE SERIES FWB190 WOOD BONGOS / DESIGNER SERIES</b>														
FWB190	6 3/4"			XX				XX	XX	HEAD-38	SSR-18	LUG-22		84/85
FWB190	8"			XX				XX	XX	HEAD-39	SSR-19	LUG-22		84/85
<b>FREE RIDE SERIES FWB200 WOOD BONGOS</b>														
FWB200	6 3/4"			XX				XX	XX	HEAD-38	SSR-20	LUG-22		85
FWB200	8"			XX				XX	XX	HEAD-39	SSR-21	LUG-22		85
<b>LUIS CONTE ARTIST SERIES WOOD BONGO</b>														
LC300	6 3/4"			XX				XX	XX	TS-C-13	TTR-31	LUG-22		86
LC300	8"			XX				XX	XX	TS-C-14	TTR-32	LUG-22		86
<b>FREE RIDE SERIES FWB300 WOOD BONGO</b>														
FWB300	6 3/4"			XX				XX	XX	TS-C-13	TTR-31	LUG-22		86
FWB300	8"			XX				XX	XX	TS-C-14	TTR-32	LUG-22		86
<b>FREE RIDE SERIES FFB200 FIBERGLASS BONGOS</b>														
FFB200	6 3/4"			XX				XX	XX	TS-B-50	SSR-34	LUG-23		86
FFB200	8"			XX				XX	XX	TS-B-51	SSR-35	LUG-23		86
<b>FREE RIDE SERIES FFB400 FIBERGLASS BONGOS / DESIGNER SERIES</b>														
FFB400	7"			XX				XX	XX	TS-C-02	SSR-02	LUG-07		87
FFB400	8 1/2"			XX				XX	XX	TS-C-03	SSR-04	LUG-07		87
<b>FREE RIDE SERIES MINI WOOD BONGOS</b>														
FWB100	3 1/2"			XX				XX	XX	TS-B-31	SSR-16	LUG-19		87
FWB100	4 1/4"			XX				XX	XX	TS-B-32	SSR-17	LUG-19		87
<b>FREE RIDE SERIES FWB400 WOOD BONGO</b>														
FWB400	7"			XX				XX	XX	TS-C-02	SSR-02	LUG-07		88
FWB400	8 1/2"			XX				XX	XX	TS-C-03	SSR-04	LUG-07		88
<b>FREE RIDE SERIES COLLECTION WOOD BONGO</b>														
CS400	7"			XX				XX	XX	TS-C-02	SSR-02	LUG-07		89
CS400	8 1/2"			XX				XX	XX	TS-C-03	SSR-04	LUG-07		89
<b>FREE RIDE SERIES WOODCRAFT BONGO</b>														
WB500	7"			XX				XX	XX	TS-C-11	TTR-26	LUG-07		89
WB500	9"			XX				XX	XX	TS-C-12	TTR-27	LUG-07		89
<b>SPARE PARTS FOR STANDS</b>														
Memory Clamp, chrome, for middle stand tube for TMB + TMB-S				STAND-07									90	
Memory Clamp, chrome, for lower stand tube for TMB + TMB-S				STAND-09									90	
Memory Clamp, chrome, for upper stand tube for TMB				STAND-11									90	
Fast Lock Set, chrome for TMB + TMB-S				STAND-14									90	
Rubber Feet (set of 3 pcs.) for all Bongo Stands				STAND-16									90	
L-Shaped Clamp for top part for TMB + TMB-S				STAND-18									90	
Upper Stand Section, complete for TMB				STAND-34									90	
<b>OTHER PARTS</b>														
Lug Oil				SPARE-09										
Tuning Key, 13mm + 14mm, L-shaped, chrome				KEY-02										



Timo Böttcher



Christin Bartels



Hanna Gensheimer

Model No.	Size	Material	Features	SPARE PARTS					
				Head	Rim	Lug	Bracket	Page	
<i>Dancing Percussion</i>		Aluminum							
		Copper							
		Rubber Wood							
		Premium Fiberglass							
		Synthetic Heads							
		Hand selected buffalo heads							
		Natural rawhide							
		True Skin Buffalo Heads							
		TTR-Rim							
		Hand hammered shell							
<b>FIBERGLASS DANCING CONGA</b>									
HC301	8 1/2"								
<b>FIBERGLASS DANCING DJEMBE</b>									
HDJ400	12"								
<b>FIBERGLASS MINI DANCING DJEMBES</b>									
HDJ200	8"								
<b>FIBERGLASS FAMILY DRUMS</b>									
HFDD1	8 3/4"								
HFDD2	8"								
HFDD3	7 1/2"								
<b>OTHER PARTS</b>									
A Go Go Bell Holder				STBAGH					
Tuning Key				KEY-08					

Hassawe Ba

Alexander Greims

Roque Rosales Alarcon

*Spare Parts*

# Spare Parts

Djembes

Model No.	Size	Height	Material							Features				SPARE PARTS				
			Mahogany Wood	Rubber Wood	Premium Fiberglass	American White Ash	True Skin Goat Heads	True Skin Calf Heads	Floatune Tuning System	Rope Tuning System	SSR-Rim	Head	Rim	Lug	Bracket	Page		
<b>HEADLINER® SERIES ROPE TUNED DJEMBES CONGO SERIES</b>																		
HDJ1-M	10"	20"	X							X				HEAD-53				94
HDJ1-L	12"	24"	X							X				HEAD-54				94
HDJ1-XL	13"	25"	X							X				HEAD-55				94
<b>HEADLINER® SERIES ROPE TUNED DJEMBES TRIBAL SERIES</b>																		
HDJ2-M	10"	20"	X							X				HEAD-53				95
HDJ2-L	12"	24"	X							X				HEAD-54				95
HDJ2-XL	13"	25"	X							X				HEAD-55				95
<b>ORIGINAL AFRICAN STYLE ROPE TUNED WOOD DJEMBE WATER RHYTHM SERIES</b>																		
ADJ2-M+BAG	10"	20"	X							X				HEAD-53				97
ADJ2-L+BAG	12"	24"	X							X				HEAD-54				97
ADJ2-XL+BAG	13"	25"	X							X				HEAD-55				96
<b>ORIGINAL AFRICAN STYLE ROPE TUNED WOOD DJEMBE EARTH RHYTHM SERIES</b>																		
ADJ3-M+BAG	10"	20"	X							X				HEAD-53				97
ADJ3-L+BAG	12"	24"	X							X				HEAD-54				97
ADJ3-XL+BAG	13"	25"	X							X				HEAD-55				96
<b>ORIGINAL AFRICAN STYLE ROPE TUNED WOOD DJEMBE MOON RHYTHM SERIES</b>																		
ADJ4-M+BAG	10"	20"	X							X				HEAD-53				97
ADJ4-L+BAG	12"	24"	X							X				HEAD-54				97
ADJ4-XL+BAG	13"	25"	X							X				HEAD-55				96
<b>PROFESSIONAL AFRICAN DJEMBES</b>																		
PROADJ1	12"	24"	X							X				HEAD-54				99
PROADJ2	12"	24"	X							X				HEAD-54				99
PROADJ3	14"	26"	X							X				HEAD-54				99
<b>AFRICAN BOUGARABOU</b>																		
ABGB-L	12"	24"	X							X				HEAD-63				100
<b>ROPE TUNED WOOD DJEMBES</b>																		
DJWR3	12"	24 1/4"		X					X	X				TS-CA-01				100
<b>HEADLINER® SERIES WOOD DJEMBES / DESIGNER SERIES DJEMBE</b>																		
HDJ600	12"	23 1/2"		X										HHEAD12W	HRIM12W	HDLUGW	HDBRACKET-02	101
<b>FLOATUNE SERIES 12 3/4" WOOD DJEMBES</b>																		
DJW2	12 3/4"	25 1/4"		X			X	X	X	X				TS-G-02	SSR-30	LUG-04		102
<b>FLOATUNE SERIES 12" WOOD DJEMBES</b>																		
DJW3	12"	24 1/4"		X		X	X	X	X	X				TS-G-01	SSR-29	LUG-04		102/103
<b>FLOATUNE SERIES FIBERGLASS DJEMBES</b>																		
DJF3	12"	24 1/4"		X		X	X	X	X	X				TS-G-01	SSR-29	LUG-05		103
<b>SPARE PARTS FOR STANDS</b>																		
Rubber Feet (set of 3 pcs.) for Steely-II Stand												STAND-35		104				
Rubber Tops (set of 3 pcs.) for Steely-II Stand												STAND-21		104				
Socket Screw (set of 2 pcs.) chrome												STAND-27		104				
Fast Lock Set, chrome												STAND-14		104				
Rubber Feet (set of 3 pcs.) for Djembe Stand												STAND-16		104				
<b>OTHER PARTS</b>																		
Lug Oil												SPARE-09						
Tuning Key, 13mm + 14mm, L-shaped, chrome												KEY-02						

SPARE PARTS																
Model No.	Size	Material				Features				Head	Rim	Lug	Bracket	Page		
<b>Timbales</b>		German B8 cymbal bronze	Solid brass	Stainless steel	Black powder coated steel	Steel	Hammered shells	Two worked in flanges	Cuban style (bottom edge)	Special brackets cast	Floatune Tuning System					
<b>HEADLINER® SERIES</b>																
HT1314	13"					X	X					HEAD-24	RIM-37	LUG-26	BRACKET-18	108
HT1314	14"					X	X					HEAD-22	RIM-38	LUG-26	BRACKET-18	108
<b>DRUMMER TIMBALE</b>																
MDT13CH	13"					X						HEAD-43	RIM-31	LUG-21	BRACKET-13	108
<b>MINI TIMBALE</b>																
MIT810CH	8"					X						HEAD-41	RIM-29	LUG-21	BRACKET-13	108
MIT810CH	10"					X						HEAD-42	RIM-30	LUG-21	BRACKET-13	108
<b>ARTIST SERIES, Taku Hirano, HAND-BALE</b>																
MHT13	13"					X						HEAD-43	RIM-47	LUG-21	BRACKET-13	109
<b>ARTIST SERIES, Dave Mackintosh, ATTACK TIMBALE</b>																
MDT88	8"					X						HEAD-41	RIM-29	LUG-21	BRACKET-13	109
<b>MARATHON® SERIES</b>																
MT1415	14"					X	X					HEAD-22	RIM-23	LUG-17	BRACKET-12	110
MT1415	15"					X	X					HEAD-23	RIM-24	LUG-17	BRACKET-12	110
<b>ARTIST SERIES, Amadito Valdés</b>																
AV1BK	14"					X	X			X		HEAD-22	RIM-27	LUG-17		111
AV1BK	15"					X	X			X		HEAD-23	RIM-28	LUG-17		111
<b>FLOATUNE SERIES</b>																
TI1BK	13"					X	X			X		HEAD-24	RIM-21	LUG-17		111
TI1BK	14"					X	X			X		HEAD-22	RIM-22	LUG-17		111
<b>ARTIST SERIES, Luis Conte</b>																
LC1	14"		X	X			X	X	X	X		HEAD-22	RIM-19	LUG-16	BRACKET-08 brass	112
LC1	15"		X	X			X	X	X	X		HEAD-23	RIM-20	LUG-16	BRACKET-09 brass, small	112
															BRACKET-10 chrome	112
															BRACKET-11 chrome, small	112
<b>PROFESSIONAL SERIES</b>																
BT1415	14"	X					X	X	X			HEAD-22	RIM-19	LUG-16	BRACKET-10 chrome	113
BT1415	15"	X					X	X	X			HEAD-23	RIM-20	LUG-16	BRACKET-11 chrome, small	113
<b>SPARE PARTS FOR STANDS</b>																
Timbale Stand, chrome										TMT						
Cowbell Holder, complete for MEINL Timbales										STAND-01						
Cowbell Holder, complete for HT1314 Timbales										HDSTAND-01						
Memory Clamp, chrome for middle stand tube										STAND-07						
Memory Clamp, black for middle stand tube										STAND-08						
Memory Clamp, chrome for lower stand tube										STAND-09						
Memory Clamp, black for lower stand tube										STAND-10						
Fast Lock Set, chrome										STAND-14						
Fast Lock Set, black										STAND-15						
Rubber Feet (set of 3 pcs.) for Timbales Stand										STAND-16						
<b>OTHER PARTS</b>																
Lug Oil										SPARE-09						
Tuning Key, 13mm + 14mm, L shaped, chrome										KEY-02						

SPARE PARTS														
														Page
<b>Foot Cabasa</b>														
<b>OTHER PARTS</b>														
Coil springs										SPARE-20		133		

# Spare Parts

Ritual Drums

										SPARE PARTS							
Model No.	Size	Material		Features						Head	Rim	Lug	Bracket	Page			
		Aluminum	Copper	Rubber Wood	Premium Fiberglass	Synthetic Heads	Hand selected buffalo heads	Natural rawhide	True Skin Buffalo Heads	TTR-Rim	Hand hammered shell	Hand engraved shell					
<b>TALKING DRUM</b>																	
TD7	7 1/2"					X	X						HEAD-35	RIM-25			134
<b>BATAS</b>																	
BA1	5 1/4"					X	X						HEAD-07	RIM-04	LUG-12		137
BA1	8"					X	X						HEAD-08	RIM-05	LUG-12		137
BA2	5 3/4"					X	X						HEAD-09	RIM-06	LUG-12		137
BA2	8 3/4"					X	X						HEAD-10	RIM-07	LUG-12		137
BA3	6 3/4"					X	X						HEAD-11	RIM-08	LUG-12		137
BA3	12"					X	X						HEAD-12	RIM-09	LUG-12		137
<b>WOOD CONGUITAS</b>																	
HCG89	8"			X		X							HEAD-05	TTR-05	LUG-11	HDBRACKET-02	137
HCG89	9"			X		X							HEAD-06	TTR-08	LUG-11	HDBRACKET-02	137
<b>TAMBORA</b>																	
MTA1	11"			X					X				TS-B-09 (NT)	RIM-03	LUG-10	BRACKET-06	137
MTA1	11"			X					X				TS-B-10 (WH)	RIM-03	LUG-10	BRACKET-06	137
<b>OTHER PARTS</b>																	
BEATER (Rattan) for Talking Drum										SPARE-10					134		
BEATER (Mahogany Wood) for Talking Drum										SPARE-23					135		

Doombeks / Darbukas

										SPARE PARTS							
Model No.	Size	Material		Features						Head	Rim	Lug	Bracket	Page			
		Aluminum	Copper	Rubber Wood	Premium Fiberglass	Synthetic Heads	Hand selected buffalo heads	Natural rawhide	True Skin Buffalo Heads	TTR-Rim	Hand hammered shell	Hand engraved shell					
<b>COPPER DOUMBЕК</b>																	
HE-3012	8 1/2"		X			X						X	HE-HEAD-3000				144
<b>ALUMINUM DOUMBЕKS</b>																	
HE-3030	8 1/2"	X				X					X		HE-HEAD-3000				144
HE-3400	8 1/2"	X				X							HE-HEAD-3000				145
HE-3020	8 1/2"	X				X							HE-HEAD-3000				144
HE-3000	8 1/2"	X				X							HE-HEAD-3000				144
<b>PROFESSIONAL DOUMBЕК</b>																	
HE-5000	9"	X				X							HE-HEAD-5000				144
<b>ALUMINUM DARBUKAS</b>																	
HE-100	5 1/3"	X				X							HE-HEAD-100				146
HE-101	5 7/8"	X				X							HE-HEAD-101				146
HE-102	6 1/2"	X				X							HE-HEAD-102				146
HE-103	7 1/4"	X				X							HE-HEAD-103				146
HE-104	8"	X				X							HE-HEAD-104				146
HE-113	7 1/4"	X				X					X		HE-HEAD-103				147
HE-114	8"	X				X					X		HE-HEAD-104				147
<b>ALUMINUM JINGLE DARBUKAS</b>																	
HE-314	8"	X				X					X		HE-HEAD-104				146
HE-315	8 1/4"	X				X					X		HE-HEAD-315				146
<b>COPPER DARBUKAS</b>																	
HE-214	7 1/2"		X			X					X		HE-HEAD-214				147
HE-215	7 7/8"		X			X					X		HE-HEAD-215				147
HE-204	7 1/2"		X			X					X		HE-HEAD-204				147
HE-205	7 7/8"		X			X					X		HE-HEAD-205				147

**Nino<sup>®</sup>**  
Percussion

Model No.	Size	Height	Material	Features	SPARE PARTS					
					Head	Rim	Lug	Bracket	Page	
			Rubber, Wood Premium Fiberglass ABS Plastic Mahogany, Wood	Hand selected buffalo heads Hand selected goat heads Rounded rims Floatune Tuning System Rope Tuning System						
<b>CONGA SETS</b>										
NIN089	8"	22"			HEAD-NIN089-8	RIM-NIN089-8	LUG-NIN089	BRACKET-NI89	154	
NIN089	9"	22"			HEAD-NIN089-9	RIM-NIN089-9	LUG-NIN089	BRACKET-NI89	154	
NIN0910	9"	28"			HEAD-NI910-9	RIM-NI910-9	LUG-NIN0910	BRACKET-NI89	155	
NIN0910	10"	28"			HEAD-NI910-10	RIM-NI910-10	LUG-NIN0910	BRACKET-NI89	155	
<b>BONGOS</b>										
NIN03	6 1/2"				HEAD-NIN03-65	RIM-NI3-65-BK	LUG-NIN03		156	
NIN03	7 1/2"				HEAD-NIN03-75	RIM-NI3-75-BK	LUG-NIN03		156	
NIN03	6 1/2"				HEAD-NIN03-65	RIM-NI3-65-BL	LUG-NIN03		156	
NIN03	7 1/2"				HEAD-NIN03-75	RIM-NI3-75-G	LUG-NIN03		156	
NIN017	6 1/2"				HEAD-NIN03-65	RIM-NI3-65-BK	LUG-NIN03		156	
NIN017	7 1/2"				HEAD-NIN03-75	RIM-NI3-75-BK	LUG-NIN03		156	
<b>HAND DRUMS</b>										
NIN036	10"				HEAD-NIN036				156	
NIN037	12"				HEAD-NIN037				156	
NIN038	10"				HEAD-NIN038				156	
NIN039	12"				HEAD-NIN039				156	
<b>AFRICAN STYLE ROPE TUNED WOOD DJEMBES</b>										
NINO-ADJ2-XS	6 1/4"-8 1/4"	11 3/4"			HEAD-60				174	
NINO-ADJ2-S	7"-8 1/2"	15 3/4"			HEAD-61				174	
<b>AFRICAN STYLE ROPE TUNED WOOD DJEMBES</b>										
NINO-ADJ3-XS	6 1/4"-8 1/4"	11 3/4"			HEAD-60				174	
NINO-ADJ3-S	7"-8 1/2"	15 3/4"			HEAD-61				174	
<b>AFRICAN STYLE ROPE TUNED WOOD DJEMBES</b>										
NINO-ADJ4-XS	6 1/4"-8 1/4"	11 3/4"			HEAD-60				174	
NINO-ADJ4-S	7"-8 1/2"	15 3/4"			HEAD-61				174	
<b>WOOD DJEMBE</b>										
NIN023	10"	21"			HEAD-NIN023	RIM-NIN023	LUG-NIN023		175	
<b>SPARE PARTS FOR STANDS</b>										
8" Basket Stand for NIN089					NISTAND-08				154	
9" Basket Stand for NIN089					NISTAND-09				154	
9" Basket Stand for NIN0910					NISTAND9				155	
10" Basket Stand for NIN0910					NISTAND10				155	
<b>OTHER PARTS</b>										
Lug Oil					SPARE-09					
Wood Beater					NIN09					
Triangle Beater					NIN0567					
Tuning Key, 13mm, chrome					KEY-04					

Sabrina Rupp

Thomas Barabas

Lukas

Sharon Bond

Gregor



*Spare Parts*

RITUAL DRUMS, DOUMBEKS/DARBUKAS  
NINO<sup>®</sup> PERCUSSION

# METAL Online

Unlike most companies we are not just about the business. We are focused on you... the player... the one making music with our instruments. With all the new social networks this has become much easier. We invite you to send a message with an idea, or just to say what like or don't like. You can find us on facebook, myspace and twitter.

P.S. - For the latest info about our artist, news and blog be sure to check out [mein1percussion.com](http://mein1percussion.com).... we have tons of new videos too.

[mein1percussion.com](http://mein1percussion.com)



videos



blog



artists



twitter.com/meinpercussion



facebook.com/meinpercussion



myspace.com/meinpercussion



# “GREETINGS TO OUR FRIENDS AND FANS,”

I hope everything is well with all of you.

2009 was another outstanding year for MEINL Percussion! Despite all the gloomy news of global recession and financial crisis, here at MEINL, we experienced growth. We expanded our market share, and we added new personnel in our offices.

Further growth is our outlook for 2010 as the trends continue. We have developed new marketing channels and forged closer connections with you, both of which fuel our trajectory. We are engaging with the public in many ways, to make our company as open as possible. That being said, we also take all feedback seriously, so that we can continue to make the best percussion instruments for you!

Believe it or not, for 2010 we cooked up a whopping 111 new and unique instruments, and improved some of our existing models. We work with the best craftsmen and talented artists from all over the world. That's the way we get things done! It's been a huge project, and we are proud to present the fruits of our labor to you in this catalog.

Thank you once again to everyone who helped me make this possible!

Looking forward to a great 2010.

Kind regards,

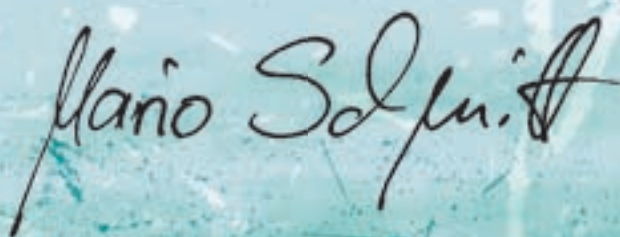

Mario Schmitt  
Product Manager,  
MEINL Percussion

# IMPRESSUM

All features are subject to change without notice. Not responsible for typographic errors. No part of this book may be reprinted, reproduced, or included in any online service in any form in whole or in part, without the prior permission of MEINL.

© 2010 Roland Meinl Musik-instrumente GmbH & Co. KG

## ADVERTISING

CONCEPT & DESIGN BY:

infowerk ag

CONTENT & DIRECTION BY:

Udo Heubeck, Mario Schmitt

MEINL WOULD ALSO LIKE TO  
THANK:

Christian Habermeier  
and Sebastian Jäger,  
[www.studio-waldeck.de](http://www.studio-waldeck.de)

Chris Nöth,  
[www.chrisnoeth.de](http://www.chrisnoeth.de)

Tanja Hastedt,  
[www.designetcetera.de](http://www.designetcetera.de)

Till Dechent, Tobias Küpper,  
and Julian Wildgruber,  
[www.55films.de](http://www.55films.de)

MEINL GLOBAL HEADQUARTER

Am Bahnhof 2  
91468 Gutenstetten  
Germany

MEINL USA L.C.

3300 Ambrose Avenue  
Nashville, TN 37207  
USA

This catalogue has been printed  
on FSC certificated paper

Printed in Germany M-CA401209





*Passion for Percussion*



*meinpercussion.com*

