

THE ULTIMATE SELECTION

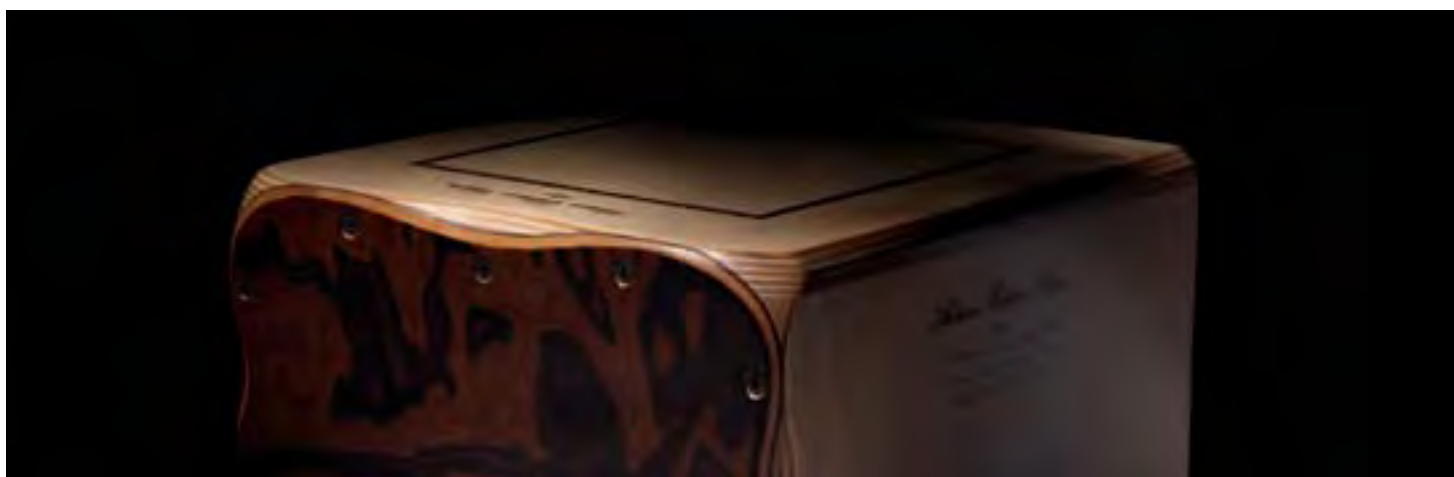
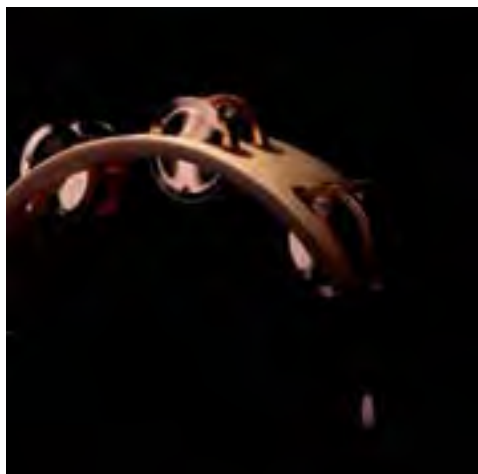

THE MEINL BOOK
OF PERCUSSION
2012

2012
THE ULTIMATE SELECTION
EXCLUSIVELY PRESENTED BY **MEINL**

MORE THAN 60 NEW ITEMS

MEINL Percussion is proud to be the leading developer of percussion instruments. We work hard to stimulate the market and broaden musical horizons with our ultimate selection.

Here is an over-view of what's new in our line-up for 2012.

We have over 60 new items, something in almost every category and price range.



NEW!
078
SLAP-TOP CAJON



NEW!
015
HEADLINER® TRADITIONAL DESIGNER SERIES CONGAS



NEW!
080
CAJON ADD-ONS



NEW!
042
HEADLINER® SERIES ROPE TUNED WOOD DJEMBES



NEW!
088
DRUMMER SNARE TIMBALES



NEW!
065
SHEKERE



NEW!
115
ARTISAN EDITION TAMBOURINES



NEW!
077
ARTISAN EDITION CAJONS



NEW!
121
MULTI -JINGLE STICK



NEW!
126
PROFESSIONAL WOOD BLOCKS



NEW!
126
CASTANETS



NEW!
129
UNIVERSAL TRIANGLE



NEW!
140
MARACLAVES



NEW!
141
MERENGUE GÜIRA

AND MANY MORE...

Congas	008
Bongos	030
Djembes	040
Dancing Percussion	049
Darbukas	054
Doumbeks	058
Tablas	060
Ritual Drums	062
Ibo Drums	066
Cajons	068
Cajon Add-Ons	080
Foot Percussion	081
Timbales	082
Samba	090
Frame Drums	102
Tambourines	110
Cowbells	122
Blocks & Castanets	126
Metal Effects	128
Chimes	130
Cabasas	132
Kalimbas	133
Claves	134
Sound Effects	135
Shakers	136
Hand Percussion	140
Rainmaker & Rainsticks	142
Didgeridoos	143
Candela Percussion Cymbals	144
Sticks & Beaters & Scrapers	146
Stands & Tables	148
Hardware	154
Accessories	156
Bags	158
Merchandise	166

PAGE

PRODUCT GROUP



IT'S A LONG ROAD

from an idea, to a working prototype, to the finished instrument. There's a lot of testing, refining and more testing along the way.

What kind of metal to use? What alloy? Should it be plated? How will all that affect the sound? What about the wood? And so on.

It has to come together in a way that not only sounds great, but is also playable and durable. It's our passion for details that makes MEINL different. We put together creative people's ideas, with German engineering and modern production facilities.

MEINL has become a world leader in percussion by seeing the creative process through, from inspiration to finished instrument.



THE MIPA AWARD GOES TO...



...the **MEINL Artist Series Timbales (Luis Conte)** in the category "Best Percussion Product 2000".



...the **MEINL Collection Series Wood Bongo** in the category "Best Percussion Product 2001".



...the **MEINL Professional Series Congas** in the category "Best Percussion Product 2002".



...the **MEINL Artist Series Congas (Luis Conte)** in the category "Best Percussion Product 2005".

Our Research & Development process is a collaboration between very creative people: Players and designers. We are all passionate about what we do. The MEINL Percussion approach to R & D is open-minded, straightforward, and based on mutual respect. That's how we get things done. That's why MEINL won the most MIPA awards of all percussion brands.



...the **MEINL Conga Cajon** in the category "Best Percussion Product 2006".

...the **MEINL Foot Cabasa** in the category "Best Percussion Product 2008".



...the **MEINL Artist Series Signature Hand-Bale (Taku Hirano)** in the category "Best Percussion Product 2010".



...the **MEINL Journey Series Rope Tuned Fiberglass Djembe** in the category "Best Percussion Product 2011".

CONGAS



01 Rubber Wood stock is sawed to desired thickness for conga staves.



02 Glued double-layered staves are bent into shape in a large press.

03 After bending, the staves have to be carefully checked for proper shape.



04 A set of staves are pre-assembled and glued together by hand.

05 The profile is cut by lathe.

06 Conga rims are being checked and prepared for the finishing process.

07 Sanding a perfect surface is skilled work.

08 Leopard burl congas on the drying floor.

09 Logo is hand silk screened on a conga head.

10 Final check of the lacquering before mounting the hardware.





NEW!



THESE CONGAS COME WITH HEIGHT ADJUSTABLE BASKET STANDS

Pearl White, 10" & 11"
HC55PW

NEW!



Maple, 10" & 11"
HC55MA

10" & 11" WOOD CONGA SETS

The 10" & 11" pair is the perfect set of congas to get you started! The compact size is easy for young players to handle, light to carry, and has a full, rich sound. You can develop a full foundation of conga techniques and rhythms with these student-friendly drums.

SIZES 10" & 11" Conga Set
28" tall

MATERIAL Rubber Wood
(*Hevea brasiliensis* Muell.-Arg.)

FEATURES Hand selected buffalo heads
8 mm strong tuning lugs
Original MEINL style tuning brackets
2 mm rounded rims
Black powder coated hardware

INCLUDES Height adjustable basket stands (patented) with quick set up system
Tuning key

COLOURS BK = Black
MA = Maple
NT = Natural
PW = Pearl White
VSB = Vintage Sunburst
WRB = Wine Red Burst

FINISH High gloss

PATENTS Basket Stand patents:
Ergo arched rubber bracing (CN, DE, FR, GB, LU, US patent)
U-shaped notch (US patent)
L-shaped leg (DE patent)



RUBBER RINGED BOTTOM FOR MORE STABILITY WHEN PLAYED WITHOUT STANDS

ERGO ARCHED RUBBER BRACING





Black, 10" & 11"
HC55BK



Wine Red Burst, 10" & 11"
HC55WRB



Vintage Sunburst, 10" & 11"
HC55VSB



Natural, 10" & 11"
HC55NT



BLACK POWDER COATED
2 MM ROUNDED RIM



HEADLINER® SERIES CONGAS



Pearl White, 11" & 12"
HC512PW

ALL 12" CONGAS ARE EQUIPPED WITH SIX TUNING LUGS FOR BETTER TUNING CONSISTENCY



Maple, 11" & 12"
HC512MA

11" & 12" WOOD CONGA SETS

The 11" & 12" pair is a full-sized entry level conga set. They have superb projection, warm tones, light weight and features found on professional congas. They offer outstanding quality and great value in the budget price range. This is a pair of congas you will want to keep around as you develop your skills.

SIZES 11" & 12" Conga Set
28" tall

MATERIAL Rubber Wood
(*Hevea brasiliensis* Muell.-Arg.)

FEATURES Hand selected buffalo heads
8 mm strong tuning lugs
Original MEINL style tuning brackets
2 mm rounded rims
Black powder coated hardware

INCLUDES Height adjustable basket stands (patented) with quick set up system
Tuning key

COLOURS BK = Black
MA = Maple
NT = Natural
PW = Pearl White
VSB = Vintage Sunburst
WRB = Wine Red Burst

FINISH High gloss

RUBBER RINGED BOTTOM FOR MORE STABILITY WHEN PLAYED WITHOUT STANDS

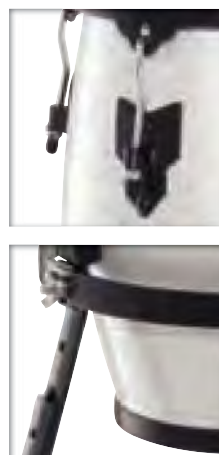

8 MM STRONG TUNING LUGS



Black, 11" & 12"
HC512BK



Wine Red Burst, 11" & 12"
HC512WRB



Vintage Sunburst, 11" & 12"
HC512VSB



Natural, 11" & 12"
HC512NT

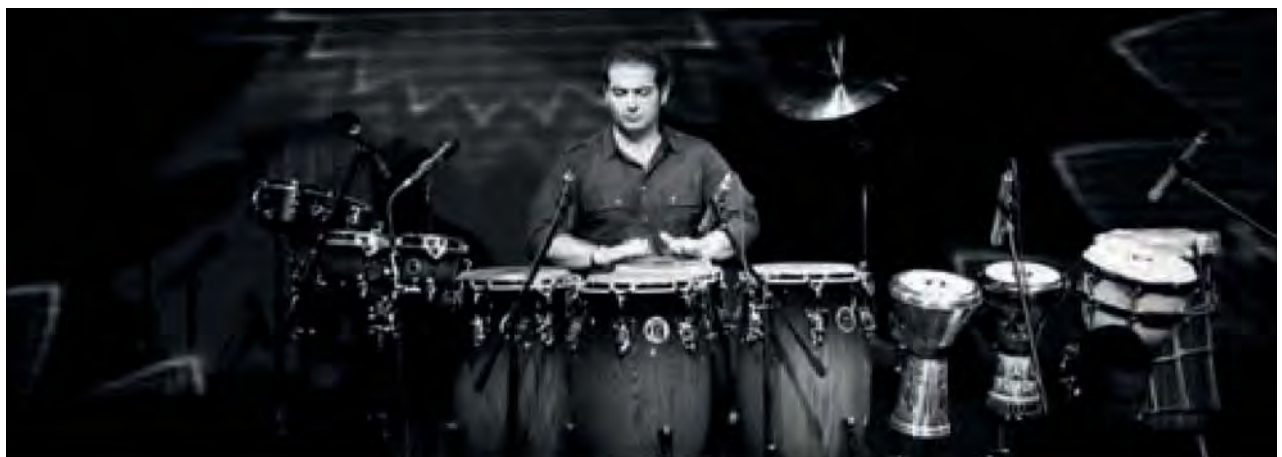

HOMAYOUN NASIRI, IRAN

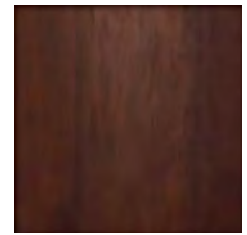

VINTAGE WINE BARREL

Vintage Wine Barrel, 10"
HC10VWB-M

Vintage Wine Barrel, 11"
HC11VWB-M

Vintage Wine Barrel, 12"
HC12VWB-M

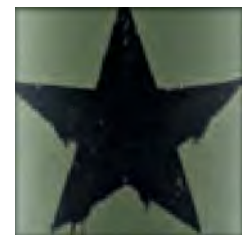

ARMY ISSUE FINISH

Army Issue, 10"
HC10AI

Army Issue, 11"
HC11AI

Army Issue, 12"
HC12AI

HEADLINER® DESIGNER SERIES CONGAS

These congas are offered individually, and you can make up a trio of the three singles: Nino, Quinto and Conga. These three sizes create a full tonal range. Headliner® Designer Series Congas are available in three exciting finishes.

SIZES 10" Nino, 11" Quinto, 12" Conga
28" tall

MATERIAL Rubber Wood
(*Hevea brasiliensis* Muell.-Arg.)

FEATURES Hand selected buffalo heads
8 mm strong tuning lugs
Original MEINL style tuning brackets
2 mm rounded rims
Black powder coated hardware
HTC: 5 mm traditional TTR-Rims

INCLUDES Height adjustable basket stands (patented) with quick set up system
Tuning key

DESIGNS AI = Army Issue
VWB-M = Vintage Wine Barrel
WB-M = Walnut Brown

FINISH Matte



CARLOS MALDONADO, PUERTO RICO

HEADLINER® TRADITIONAL DESIGNER SERIES CONGAS

NEW!



WALNUT BROWN

CONGAS

Cubano Retro, 10"
HTC10WB-M

Cubano Retro, 11"
HTC11WB-M

Cubano Retro, 12"
HTC12WB-M



BLACK POWDER COATED 5 MM
TRADITIONAL TTR-RIM



ROBBIE HARRIS, IRELAND



ALFONSO GARRIDO, GERMANY



JEAN-PHILIPPE BATAILLEY, FRANCE



RIAAN VAN RENSBURG, SOUTH AFRICA



TRADITIONAL INSTRUMENTS MADE MODERN

ARTISTS



LUIS CONTE, USA

1



Black, 10"
HFC10BK

Black, 11"
HFC11BK

Black, 12"
HFC12BK

PREMIUM FIBERGLASS GUARANTEES LONG DURABILITY AND RESISTANCE TO CLIMATIC CHANGES

2

LUIS CONTE, USA



Natural, 11"
LC11NT-M

Natural, 11 3/4"
LC1134NT-M

Natural, 12 1/2"
LC1212NT-M



A COMBINATION OF THE CHARM AND SOUND OF THE OLD TRADITIONAL CUBAN DRUMS WITH MODERN FEATURES AND INNOVATIONS

1 HEADLINER® FIBERGLASS SERIES CONGAS

This material has long been used for congas shells because of its durability and resistance to climactic changes, while offering a full spectrum and brilliance in sound.

- SIZES** 10" Nino, 11" Quinto, 12" Conga 28" tall
- MATERIAL** Premium fiberglass
- FEATURES** Hand selected buffalo heads
8mm strong tuning lugs
Original MEINL style tuning bracket
2mm rounded rims
Black powder coated hardware
- INCLUDES** Height adjustable basket stands (patented) with quick set up system
Tuning key
- COLOUR** BK = Black

2 ARTIST SERIES LUIS CONTE CONGAS

All of Luis' needs have been met and exceeded with the MEINL Artist Series Luis Conte Signature Congas. They combine the charm and sound of the old traditional Cuban drums with modern features and innovations. These congas are equipped with traditional rims, are mounted as close to the shell as possible, and when combined with MEINL's True Skin Buffalo Heads, they enable an even more controlled sound.

- SIZES** 11" Quinto, 11 3/4" Conga, 12 1/2" Tumba 30" tall
- MATERIAL** Two ply Rubber Wood (*Hevea brasiliensis* Muell.-Arg.)

- FEATURES** True Skin Buffalo Heads
8 mm strong tuning lugs
5 mm traditional TTR-Rims
Black powder coated hardware
- INCLUDES** MEINL Conga Saver (CN, TH, US patent)
MEINL Soundpads
Accessory pouch
L-shaped tuning key
Tune Up Oil
- COLOUR** NT-M = Natural
- FINISH** Matte

MARATHON® DESIGNER SERIES CONGAS

CONGAS

1



DESIGN INSPIRED BY TAKU HIRANO, USA



Mitsudomoe, 11"
MCC11M

Mitsudomoe, 11 3/4"
MCC1134M

Mitsudomoe, 12 1/2"
MCC1212M

2



Love, Peace & Unity, 11"
MCC11LPU

Love, Peace & Unity, 11 3/4"
MCC1134LPU

Love, Peace & Unity, 12 1/2"
MCC1212LPU



DESIGN INSPIRED BY MARCIE CHAPA, USA

1 MITSUDOMOE

This Marathon® Designer Series Congas matches Taku Hirano's playing style: elegant, captivating and versatile. The congas are proudly emblazoned with the Japanese Mitsudomoe symbol, representing Man, Earth, and Heaven. The symbol became associated with the Samurai ethos, and with the art of drumming itself.

Taku explains, "The Mitsudomoe symbol has always resounded with me in that it was a link to my heritage and synonymous to not only the warriors of Japan, but also the drummers of Japan. After doing research and finding out that it was adopted by a king with the same name as myself, and that it symbolized upholding honour to the highest degree, I knew that it chose me as much as I chose it."

2 LOVE, PEACE & UNITY

Marcie Chapa sends an important message to the world with the Marathon® Designer Series Congas: "Love, Peace & Unity" "I fall in love with music each time I play." says Marcie. "Peace reminds me of where we should be. Every time I play I feel at Peace. Music has amazing powers because it is an international language that can bring Peace, Love, and Unity to us all."

SIZES	11" Quinto, 11 3/4" Conga, 12 1/2" Tumba 30" tall
MATERIAL	Rubber Wood with appliqué graphics (Hevea brasiliensis Muell.-Arg.)
FEATURES	True Skin Buffalo Heads 8 mm strong tuning lugs 2.6 mm rounded SSR-Rims Black powder coated hardware
INCLUDES	Steely II Conga Stand (patented) MEINL Conga Saver (CN, TH, US patent) Accessory pouch L-shaped tuning key Tune Up Oil
DESIGNS	LPU = Love, Peace & Unity M = Mitsudomoe
FINISH	High gloss

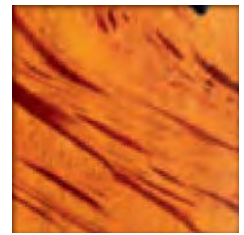

AMBER FLAME

Amber Flame, 11"
MCC11AF

Amber Flame, 11 3/4"
MCC1134AF

Amber Flame, 12 1/2"
MCC1212AF



LEOPARD BURL

Leopard Burl, 11"
MCC11LB

Leopard Burl, 11 3/4"
MCC1134LB

Leopard Burl, 12 1/2"
MCC1212LB

MARATHON® DESIGNER SERIES CONGAS

The Marathon® Designer Series Congas are made with a special lacquering technique in high gloss, have professional features and are available at a very attractive price.

SIZES 11" Quinto, 11 3/4" Conga,
12 1/2" Tumba
30" tall

MATERIAL Two ply Rubber Wood
(*Hevea brasiliensis* Muell.-Arg.)

FEATURES True Skin Buffalo Heads
8 mm strong tuning lugs
2.6 mm rounded SSR-Rims
Black powder coated hardware

INCLUDES Steely II Conga Stand (patented)
MEINL Conga Saver (CN, TH, US patent)
Accessory pouch
L-shaped tuning key
Tune Up Oil

COLOURS AF = Amber Flame
LB = Leopard Burl

FINISH High gloss

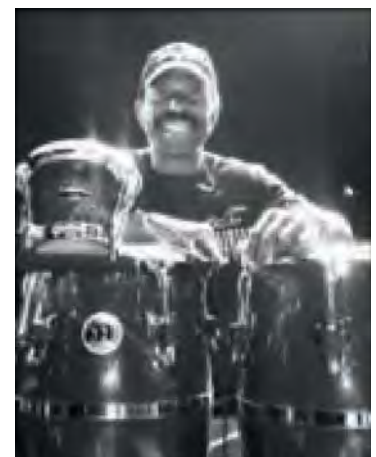

RAUL OVIEDO, MEXICO

MARATHON® CLASSIC SERIES CONGAS



Super Natural, 11"
MCC11SNT-M

Super Natural, 11 3/4"
MCC1134SNT-M

Super Natural, 12 1/2"
MCC1212SNT-M



SUPER NATURAL

CONGAS



Coffee Burst, 11"
MCC11CB

Coffee Burst, 11 3/4"
MCC1134CB

Coffee Burst, 12 1/2"
MCC1212CB



COFFEE BURST

MARATHON® CLASSIC SERIES CONGAS

The MEINL Marathon® Classic Series Congas set the standard in this price range by which other wood congas are judged. They combine professional features at a very attractive price.

SIZES 11" Quinto, 11 3/4" Conga, 12 1/2" Tumba
30" tall

MATERIAL Two ply Rubber Wood
(*Hevea brasiliensis* Muell.-Arg.)

FEATURES True Skin Buffalo Heads
8 mm strong tuning lugs
2.6 mm rounded SSR-Rims
Black powder coated hardware

INCLUDES Steely II Conga Stand (patented)
MEINL Conga Saver (patented)
Accessory pouch
L-shaped tuning key
Tune Up Oil

COLOURS CB = Coffee Burst, high gloss
SNT-M = Super Natural, matte

PATENTS Steely-II patents:
L-shaped leg and metal spike attachment (DE, TH, US patent)
U-shaped notch (US patent)
Ergonomic arched rubber bracing (CN, DE, LU, FR, UK, US patent)
Notches for quick height adjustability (German patent)
MEINL Conga Saver (CN, TH, US patent)



BLACK POWDER COATED
2.6 MM ROUNDED SSR-RIM

STEELY II CONGA STAND
(PATENTED)



BRIAN ROSENWORCEL, USA



BROWN BURL

Brown Burl, 11"
MP11BB

Brown Burl, 11 3/4"
MP1134BB

Brown Burl, 12 1/2"
MP1212BB



CHROME PLATED 4 MM ROUNDED SSR-RIM



NATURAL

Natural, 11"
MP11NT

Natural, 11 3/4"
MP1134NT

Natural, 12 1/2"
MP1212NT



AZTEC RED FADE

Aztec Red Fade, 11"
MP11ARF

Aztec Red Fade, 11 3/4"
MP1134ARF

Aztec Red Fade, 12 1/2"
MP1212ARF



PROFESSIONAL SERIES CONGAS

The Roland Meinl Professional Series Congas are the preferred conga model by many top congueros. Outstanding in look and sound, they reach from fat basses to cutting slaps with a great warm overall tone. They set the standard in the professional conga ranges.

SIZES 11" Quinto, 11 3/4" Conga, 12 1/2" Tumba 30" tall

MATERIAL Two ply Rubber Wood (*Hevea brasiliensis* Muell.-Arg.)

FEATURES True Skin Buffalo Heads
10 mm strong tuning lugs
4 mm rounded SSR-Rims
Chrome plated hardware

- INCLUDES** MEINL Conga Saver (CN, TH, US patent)
MEINL Soundpads
Accessory pouch
L-shaped tuning key
Tune Up Oil
- COLOURS** ARF = Aztec Red Fade
BB = Brown Burl
NT = Natural
- FINISH** High gloss

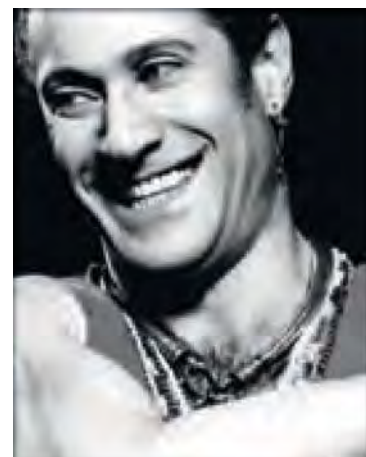

GIOVANNI IMPERATO, ITALY



BLUE SPARKLE

Blue Sparkle, 11"
FC11BSP

Blue Sparkle, 11 3/4"
FC1134BSP

Blue Sparkle, 12 1/2"
FC1212BSP

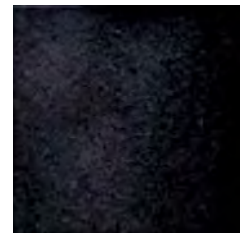

BLACK SPARKLE

Black Sparkle, 11"
FC11BKSP

Black Sparkle, 11 3/4"
FC1134BKSP

Black Sparkle, 12 1/2"
FC1212BKSP

FIBERCRAFT SERIES CONGAS

MEINL Fibercraft Congas offer great quality, durability, volume, and they are resistant to climatic changes. They have a great presence and brilliance in sound. Great for live playing and extensive road use.

SIZES 11" Quinto, 11 3/4" Conga, 12 1/2" Tumba
30" tall

MATERIAL Premium fiberglass

FEATURES True Skin Buffalo Heads
10 mm strong tuning lugs
4 mm rounded SSR-Rims
Chrome plated hardware

INCLUDES MEINL Conga Saver (CN, TH, US patent)

MEINL Soundpads

Accessory pouch

L-shaped tuning key

Tune Up Oil

COLOURS BKSP = Black Sparkle

BSP = Blue Sparkle



TRUE SKIN BUFFALO HEAD

FIBERCRAFT DESIGNER SERIES CONGAS



CHUCK PRADA, USA

CONGAS

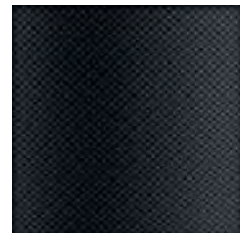

CRISP AND CLEAN CARBON FINISH

Carbon Finish, 11"
FC11CA

Carbon Finish, 11 3/4"
FC1134CA

Carbon Finish, 12 1/2"
FC1212CA

FIBERCRAFT DESIGNER SERIES CONGAS

The MEINL Fibercraft Designer Series Congas come in a dazzling carbon finish. These congas are made from premium fiberglass for dependability and great sound characteristics.

SIZES 11" Quinto, 11 3/4" Conga,
12 1/2" Tumba
30" tall

MATERIAL Premium fiberglass

FEATURES True Skin Buffalo Heads
10 mm strong tuning lugs
4 mm rounded SSR-Rims
Chrome plated hardware

INCLUDES MEINL Conga Saver (CN, TH, US patent)
MEINL Soundpads
Accessory pouch
L-shaped tuning key
Tune Up Oil

COLOUR CA = Carbon Finish

FOR MORE INFO, SCAN THIS MEINL
QR CODE WITH YOUR SMARTPHONE



1



Brown Burl, 10"
FL10BB

Brown Burl, 11"
FL11BB

Brown Burl, 12"
FL12BB

Brown Burl, 13"
FL13BB

THE FLOATUNE TUNING SYSTEM
ALLOWS THE SHELL TO VIBRATE FREELY.

2



American White Ash, 11"
MSA11AWA

American White Ash, 11 3/4"
MSA1134AWA

American White Ash, 12 1/2"
MSA121AWA



Ramon Santamaria

RAMON "MONGO" SANTAMARIA, CUBA

1 FLOATUNE SERIES CONGAS

The MEINL Floatune Tuning System is a true and unique MEINL innovation. All mounting hardware is completely isolated from the shell. This avoids the need to drill through the shell and mount hardware with bolts, which reduces the resonant vibrations of the shell.

SIZES 10" Nino, 11" Quinto, 12" Conga, 13" Tumba
30" tall

MATERIAL Two ply Rubber Wood (*Hevea brasiliensis* Muell.-Arg.)

FEATURES Floatune Tuning System
True Skin Buffalo Heads
10 mm strong tuning lugs
4 mm rounded SSR-Rims
Chrome plated hardware

INCLUDES MEINL Conga Saver (CN, TH, US patent)
MEINL Soundpads
Accessory pouch
L-shaped tuning key
Tune Up Oil

COLOUR BB = Brown Burl

FINISH High gloss

2 ARTIST SERIES CONGAS (RAMON "MONGO" SANTAMARIA)

Ramon "Mongo" Santamaria was without a doubt one of the most respected conga players ever, and a pioneer of modern Latin Jazz. During the 50's his band "Black Cuban Diamonds" laid down the foundation for an outstanding career. Ramon recorded dozens of legendary percussion albums. Worldwide Jazz hits, such as "Watermelon

Man" in 1963 and the album "Summertime" from 1980 are only two of the many recordings from this great master percussionist. Mongo has inspired more percussionists around the globe than any other conguero.

Mongo Santamaria died at the Baptist Hospital in Miami, USA in February 2003. He was 85 years old. It is with great appreciation and deepest respect that we honour our friend and his life's work with his MEINL Artist Series Mongo Santamaria Congas.

SIZES 11" Quinto, 11 3/4" Conga, 12 1/2" Tumba
30" tall

MATERIAL Two ply Americana L (*Fraxinus americana* L.)

WOODCRAFT SERIES CONGAS

3



ZEBRA FINISHED ASH

Zebra Finished Ash, 11"
WC11ZFA-M

Zebra Finished Ash, 11 3/4"
WC1134ZFA-M

Zebra Finished Ash, 12 1/2"
WC1212ZFA-M



ANTIQUÉ MAHOGANY BURST

Antique Mahogany Burst, 11"
WC11AMB

Antique Mahogany Burst, 11 3/4"
WC1134AMB

Antique Mahogany Burst, 12 1/2"
WC1212AMB

- FEATURES** True Skin Buffalo Heads
10 mm strong tuning lugs
4 mm rounded SSR-Rims
Gold tone hardware
- INCLUDES** MEINL Conga Saver (CN, TH, US patent)
MEINL Soundpads
Accessory pouch
L-shaped tuning key
Tune Up Oil
- COLOUR** AWA = American White Ash
- FINISH** High gloss

3 WOODCRAFT SERIES CONGAS

The MEINL Woodcraft Series Congas stand for tradition combined with exceptional workmanship. Only the finest hand selected materials are used to produce these premium drums. Their "Cuban Style" shells provide a broad range of different tonal characteristics.

SIZES 11" Quinto, 11 3/4" Conga, 12 1/2" Tumba
30" tall

MATERIAL Two ply American White Ash (*Fraxinus americana* L.)

FEATURES True Skin Buffalo Heads
10 mm strong tuning lugs
5 mm traditional TTR-Rims
Chrome plated hardware

- INCLUDES** MEINL Conga Saver (CN, TH, US patent)
MEINL Soundpads
Accessory pouch
L-shaped tuning key
Tune Up Oil
- COLOURS** AMB = Antique Mahogany Burst, high gloss
ZFA-M = Zebra Finished Ash, matte

IT'S OUR WORLD, WE CARE FOR IT

Actions speak louder than words! This is why we take our responsibility seriously and commit ourselves to several environmental projects. Our specially developed vacuum distillation saves 90,000 liters of drinking water, the world's most threatened resource. In order to minimize our electricity usage, all of our buildings are equipped with motion sensors and our centralized electricity controls prevents the waste of this resource. With our solar-power-plant (Photovoltaic-System) we produce enough power to supply 120 houses with electricity. All of the electricity used in our facility is produced from renewable energies. Thus we reduced our carbon monoxide emission from 216 tons per year down to zero. Reusable materials like paper, plastic or styrofoam are too precious to be wasted. We separate them for efficient recycling.



RUBBER WOOD PLANTATION FARM IN THAILAND



WOOD FROM ENVIRONMENTALLY CONTROLLED WOOD PLANTATION

Thailand is a logical manufacturing base for percussion instruments due to the fact that the Hevea Brasiliensis, which was indigenous to Brazil and later transported by way England to Asia, has been commercially grown in Southeast Asia during the last century on plantation farms for the production of Latex. The traditional plantation of Rubber Wood (*Hevea brasiliensis* Muell.-Arg.) meets all ecological requirements. Same counts for the plantation grown Mahogany Wood from Indonesia, which we use for our Original African Style Rope Tuned Wood Djembes. In a natural evolution, new trees are planted and the older ones, which have ceased to provide latex, are harvested. In this way, plenty of raw material is available and the valuable rain forest eco-system is preserved.



MATERIAL & ECOLOGY

Wood is a raw material which is present in almost every part of our daily life. Trees are an important part of the complex eco-system while healthy forests are imperative for the Earth's atmosphere. Only plantation grown Wood is used for the making of MEINL percussion instruments. This wood fulfils the CITES regulations ("Convention on International Trade in Endangered Species of Wild Fauna and Flora") and originates from environmentally controlled forests from industrial wood plantations.

BONGOS



01 Staves are matched for colour and grain.

02 The staves are laid up with glue.

03 After being glued, the staves are assembled into a hollow wooden block by hand.

04 The Macho and Hembra are cut into two separate pieces.

05 Precision is a must.

06 The footing profile is also cut on the lathe.

07 The surface and edges are hand-sanded.

08 Our proprietary Free Ride System allows the bongo to resonate freely because there are no bolts or holes drilled through the shells.

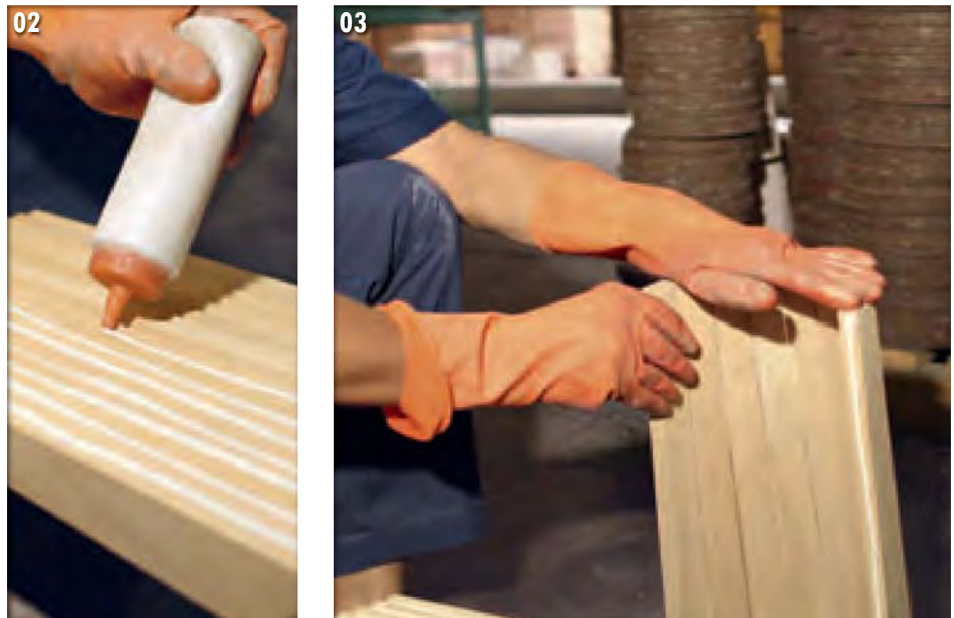



1



Black, 6 1/2" & 7 1/2"
HB50BK

STURDY ABS PLASTIC

2



Pearl White, 6 3/4" & 8"
HB100PW



CHRISTIAN FEHRE, GERMANY



Natural, 6 3/4" & 8"
HB100NT



Maple, 6 3/4" & 8"
HB100MA



Wine Red Burst, 6 3/4" & 8"
HB100WRB



Vintage Sunburst, 6 3/4" & 8"
HB100VSB

THE COMPACT SIZE MAKES THEM HANDY AND PORTABLE

1 HEADLINER® SERIES HB50 ABS BONGO

The MEINL Headliner® Series ABS Bongo has the features of traditional bongos, made from sturdy ABS plastic. The compact size makes it handy and portable.

SIZES 6 1/2" Macho & 7 1/2" Hembra

MATERIAL ABS plastic

FEATURES Hand selected buffalo heads
Rounded rims for playing comfort
Black powder coated hardware

INCLUDES Tuning key

COLOUR BK = Black

SIZES 6 3/4" Macho & 8" Hembra
MATERIAL Rubber Wood
(*Hevea brasiliensis* Muell.-Arg.)

FEATURES Hand selected buffalo heads
8 mm strong tuning lugs
2 mm rounded rims
Black powder coated hardware
Interior backing plates

INCLUDES Tuning key

COLOURS MA = Maple
NT = Natural
PW = Pearl White
VSB = Vintage Sunburst
WRB = Wine Red Burst

FINISH High gloss

2 HEADLINER® SERIES HB100 WOOD BONGOS

Headliner® Series Wood Bongos are perfect for the student or hobbyist who is looking for a high quality instrument right from the beginning.

TRADITIONAL SOLID
WOODBLOCK CONSTRUCTION



INTERIOR BACKING PLATE
ADDS STRENGTH TO
CONSTRUCTION



3



Black, 6 3/4" & 8"
HFB100BK

PREMIUM FIBERGLASS



4



Army Issue, 6 3/4" & 8"
HB100AI



5MM STRONG TTR-RIMS

NEW!



Vintage Wine Barrel, 6 3/4" & 8"
HB100VWB-M



Walnut Brown, 6 3/4" & 8"
HTB100WB-M

5



Acrylic, 6 1/2" & 7 1/2"
HB50A

FOR MORE INFO, SCAN THIS MEINL QR CODE WITH YOUR SMARTPHONE



CRYSTAL CLEAR ACRYLIC SHELLS

3 HEADLINER® SERIES HFB100 FIBERGLASS BONGO

This Bongo has all the traditional features and sounds of a wooden bongo, yet in a rugged and stable premium fiberglass body. It's perfect for the students or hobbyists who are looking for durability from their drum.

SIZES 6 3/4" Macho & 8" Hembra

MATERIAL Premium fiberglass

FEATURES Hand selected buffalo heads

8 mm strong tuning lugs

2 mm rounded rims

Black powder coated hardware

INCLUDES Tuning key

COLOUR BK = Black

4 HEADLINER® DESIGNER SERIES HB100/HTB100 WOOD BONGOS

The MEINL Headliner® Designer Series Bongos offer three finishes. The construction is in the traditional style, with a solid woodblock connection.

SIZES 6 3/4" Macho & 8" Hembra

MATERIAL Rubber Wood

(*Hevea brasiliensis* Muell.-Arg.)

FEATURES Hand selected buffalo heads

Rounded rims for playing comfort

Black powder coated hardware

WB: 5 mm strong TTR-rims

INCLUDES Tuning key

COLOURS AI = Army Issue, matte

VWB-M = Vintage Wine Barrel, matte

WB-M = Walnut Brown, matte

5 HEADLINER® SERIES HB50 ACRYLIC BONGO

The MEINL Headliner® Series Acrylic Bongo has a great look. The crystal clear acrylic shells add a touch of transparency and lightness. The shells are joined together in the traditional style.

SIZES 6 1/2" Macho & 7 1/2" Hembra

MATERIAL Acrylic

FEATURES Hand selected buffalo heads

Rounded rims for playing comfort

Black powder coated hardware

INCLUDES Tuning key

FINISH Transparent

1



Super Natural, 6 3/4" & 8"
FWB190SNT-M



White, 6 3/4" & 8"
FWB190WH



Cherry Red, 6 3/4" & 8"
FWB190CR-M



Coffee Burst, 6 3/4" & 8"
FWB190CB

2



Leopard Burl, 6 3/4" & 8"
FWB190LB



Amber Flame, 6 3/4" & 8"
FWB190AF

DESIGN INSPIRED BY
TAKU HIRANO, USA



Mitsudomoe, 6 3/4" & 8"
FWB190M

DESIGN INSPIRED BY
MARCIE CHAPA, USA



Love, Peace & Unity, 6 3/4" & 8"
FWB190LPU

1 FREE RIDE SERIES (GERMAN PATENT) FWB190 WOOD BONGOS

FWB190 Free Ride Series Wood Bongos are perfect for the ambitious beginner and for those who are looking for an affordable second set. Its professional features are outstanding in this price range.

SIZES 6 3/4" Macho & 8" Hembra

MATERIAL Rubber Wood
(*Hevea brasiliensis* Muell.-Arg.)

FEATURES MEINL Free Ride Suspension System (German patent)
Black powder coated hardware
Hand selected buffalo heads
8 mm strong tuning lugs
2.5 mm rounded SSR-Rims

INCLUDES Accessory pouch
L-shaped tuning key
Tune Up Oil

COLOURS CB = Coffee Burst, high gloss
CR-M = Cherry Red, matte
SNT-M = Super Natural, matte
WH = White, high gloss

2 FREE RIDE DESIGNER SERIES (GERMAN PATENT) FWB190 WOOD BONGOS

The Free Ride Designer Series Wood Bongo comes in four superb finishes. All other features are similar to the FWB190 Wood Bongos.

SIZES 6 3/4" Macho & 8" Hembra
MATERIAL Rubber Wood
(*Hevea brasiliensis* Muell.-Arg.)

FEATURES MEINL Free Ride Suspension System (German patent)
Unique designs
Black powder coated hardware
Hand selected buffalo heads
8 mm strong tuning lugs
2.5 mm rounded SSR-Rims

INCLUDES Accessory pouch
L-shaped tuning key
Tune Up Oil

COLOURS AF = Amber Flame
LB = Leopard Burl
LPU = Love, Peace & Unity
M = Mitsudomoe

FINISH High gloss

ARTIST SERIES & FREE RIDE SERIES WOOD BONGOS

1



Natural, 6 3/4" & 8"
LC300NT-M



LUIS CONTE, USA

FOR MORE INFO, SCAN THIS MENU
OR CODE WITH YOUR SMARTPHONE



TRADITIONAL
SOLID WOODBLOCK CONSTRUCTION

BONGOS

2



Gold Amber Sunburst, 6 3/4" & 8"
FWB200GAB



Aztec Red Fade, 6 3/4" & 8"
FWB200ARF



CHROME PLATED
ROUNDED SSR RIM

3



Natural, 6 3/4" & 8"
FWB200NT



Super Natural, 3 1/2" & 4 1/4"
FWB100SNT-M

MINI!

1 ARTIST SERIES LC300 WOOD BONGO (LUIS CONTE)

The Luis Conte Signature Wood Bongo complements his congas with its black powder coated traditional style hardware and natural finish. Luis prefers the traditional style woodblock connection between the two shells.

SIZES 6 3/4" Macho & 8" Hembra

MATERIAL Rubber Wood

(*Hevea brasiliensis* Muell.-Arg.)

FEATURES Solid woodblock connection

True Skin Cow Heads

8 mm strong tuning lugs

5 mm traditional TTR-Rims

Black powder coated hardware

INCLUDES Accessory pouch

L-shaped tuning key

Tune Up Oil

COLOUR NT-M = Natural, matte

2 FREE RIDE SERIES (GERMAN PATENT) FWB200 WOOD BONGOS

The patented MEINL Free Ride System allows the bongo shells to resonate freely.

SIZES 6 3/4" Macho & 8" Hembra

MATERIAL Rubber Wood

(*Hevea brasiliensis* Muell.-Arg.)

FEATURES MEINL Free Ride Suspension System

(German patent)

Chrome plated hardware

Hand selected buffalo heads

8 mm strong tuning lugs

2.5 mm rounded SSR-Rims

INCLUDES Accessory pouch

L-shaped tuning key

Tune Up Oil

COLOURS ARF = Aztec Red Fade, high gloss
GAB = Gold Amber Sunburst, high gloss
NT = Natural, high gloss

3 FREE RIDE SERIES (GERMAN PATENT) FWB100 MINI WOOD BONGO

The FWB100 is equipped with professional features.

SIZES 3 1/2" Macho & 4 1/4" Hembra

MATERIAL Rubber Wood

(*Hevea brasiliensis* Muell.-Arg.)

FEATURES Free Ride Suspension System

(German patent)

True Skin Buffalo Heads

Rounded SSR-Rims

Chrome plated hardware

INCLUDES Tuning key

COLOUR SNT-M = Super Natural, matte



ISMAILA M'BAYE, ITALY



BERTIL MARK, GERMANY

ANDREAS 'HABO' JOHANSSON,
SWEDEN

EPHRAIM SALZMANN, SWITZERLAND



JUAN CARLOS MELIAN, SPAIN



CHESTER THOMPSON, USA

FREE RIDE SERIES FIBERGLASS BONGOS

1



SPARKLING EFFECT

Blue Sparkle, 6 3/4" & 8"
FFB200BSP



SPARKLING EFFECT

Black Sparkle, 6 3/4" & 8"
FFB200BKSP

2



CRISP AND CLEAN CARBON FINISH

Carbon Finish, 7" & 8 1/2"
FFB400CA



SPARKLING EFFECT

Blue Sparkle, 7" & 8 1/2"
FFB400BSP



SPARKLING EFFECT

Black Sparkle, 7" & 8 1/2"
FFB400BKSP

1 FREE RIDE SERIES (GERMAN PATENT) FFB200 FIBERGLASS BONGOS

These fiberglass bongos produce a compact sound with a nice spectrum of overtones. Ideal for the ambitious beginner who is looking for a dependable bongo at an affordable price.

SIZES 6 3/4" Macho & 8" Hembra

MATERIAL Premium fiberglass

FEATURES MEINL Free Ride Suspension System (German patent)

Chrome plated hardware

Hand selected buffalo heads

8 mm strong tuning lugs

2.5 mm rounded SSR-Rims

INCLUDES Accessory pouch

L-shaped tuning key

Tune Up Oil

COLOURS BKSP = Black Sparkle
BSP = Blue Sparkle

2 FREE RIDE SERIES (GERMAN PATENT) FFB400 FIBERGLASS BONGOS

These bongos convince with a stunning sound reaching from powerful mids to sharp highs. Thanks to their fiberglass shells they are extremely durable and the perfect instrument for the working musician on the road.

SIZES 7" Macho & 8 1/2" Hembra

MATERIAL Premium fiberglass

FEATURES MEINL Free Ride Suspension System (German patent)

Chrome plated hardware

True Skin Cow Heads

8 mm strong tuning lugs

INCLUDES 3 mm rounded SSR-Rims
Resonance Shaping Area

Accessory pouch

L-shaped tuning key

Tune Up Oil

COLOURS BKSP = Black Sparkle

BSP = Blue Sparkle

CA = Carbon Finish

1



Natural, 7" & 8 1/2"
FWB400NT



Ebony Black, 7" & 8 1/2"
FWB400EBK



Cherry Red, 7" & 8 1/2"
FWB400CR



Gold Amber Sunburst, 7" & 8 1/2"
FWB400GAB



Brown Burl, 7" & 8 1/2"
FWB400BB



STUNNING BROWN BURL FINISH

1 FREE RIDE SERIES (GERMAN PATENT) FWB400 WOOD BONGOS

The MEINL FWB400 Free Ride Series Wood Bongos are the preferred bongo model by many top percussionists. Exceptional sound qualities combined with a wide variety of colours make it the perfect bongo for the working musician.

SIZES 7" Macho & 8 1/2" Hembra

MATERIAL Rubber Wood
(*Hevea brasiliensis* Muell.-Arg.)

FEATURES MEINL Free Ride Suspension System
(German patent)

Chrome plated hardware

True Skin Cow Heads

8 mm strong tuning lugs

3 mm rounded SSR-Rims

Resonance Shaping Area

INCLUDES Accessory pouch
L-shaped tuning key

Tune Up Oil

COLOURS BB = Brown Burl
CR = Cherry Red
EBK = Ebony Black
GAB = Gold Amber Sunburst
NT = Natural

FINISH High gloss



PATENTED
FREE RIDE
SUSPENSION SYSTEM

PATENTED FREE RIDE SYSTEM



JIMMY BRANLY, USA

2



Antique Mahogany Burst, 7" & 9"
WB500AMB



Zebra Finished Ash, 7" & 9"
WB500ZFA-M

CHROME PLATED 5 MM TRADITIONAL TTR RIM

3



American White Ash, 7" & 8 1/2"
CS400AWA-M



TRUE SKIN COW HEADS

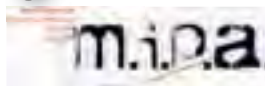

2 FREE RIDE SERIES (GERMAN PATENT) WB500 WOODCRAFT BONGOS

MEINL Woodcraft Bongos, just as the Woodcraft Congas, stand for tradition combined with exceptional workmanship. Only the finest hand selected materials are used to produce this premium bongos which produce the authentic loud bongo slap.

SIZES 7" Macho & 9" Hembra

MATERIAL American White Ash (*Fraxinus americana* L.)

FEATURES MEINL Free Ride Suspension System (German patent)
Chrome plated hardware
True Skin Cow Heads
8 mm strong tuning lugs
5 mm traditional TTR-Rims
Resonance Shaping Area

INCLUDES Accessory pouch
L-shaped tuning key
Tune Up Oil

COLOURS AMB = Antique Mahogany Burst, high gloss
ZFA-M = Zebra Finished Ash, matte

3 FREE RIDE COLLECTION SERIES (GERMAN PATENT) CS400 WOOD BONGO

This is the finest bongo available today! It is made entirely by hand and exhibit unparalleled sound, charm, and workmanship.

SIZES 7" Macho & 8 1/2" Hembra

MATERIAL American White Ash (*Fraxinus americana* L.)

FEATURES MEINL Free Ride Suspension System (German patent)
Chrome plated hardware

True Skin Cow Heads
8 mm strong tuning lugs
3 mm rounded SSR-Rims
Resonance Shaping Area

INCLUDES Accessory pouch
L-shaped tuning key
Tune Up Oil

COLOUR AWA-M = American White Ash
FINISH Matte



TRUE SKIN COW HEADS

DJEMBES



01 Raw logs of plantation grown Mahogany Wood.

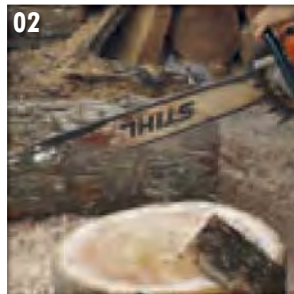

02 Mahogany logs are scaled rough-cut.



03 First phase of shaping the djembe on a lathe.

04 The interior is hollowed out.

05 This is how the djembes look after being turned on the lathe. The central core is later removed.



06 The djembes are hand-carved. There is no substitute for this level of craftsmanship.

07 The inside of the bowl is hand-carved which tunes and shapes the sound.

08 The goatskin head goes on and the tuning ropes are tightened.

09 The extra tuning rope is tied into a carrying strap.

10 The drums are checked and rechecked before being shipped.

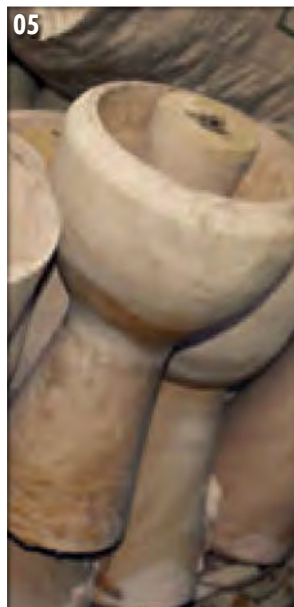



**HAND-CARVED DESIGN
ON OUR PROFESSIONAL
AFRICAN STYLE DJEMBES.**



1



Nile Series, 13"
HDJ4-XL



Nile Series, 12"
HDJ4-L



Nile Series, 10"
HDJ4-M



Nile Series, 8"
HDJ4-S

NEW!

NILE SERIES

2



Black River Series, 13"
HDJ3-XL



Black River Series, 12"
HDJ3-L



Black River Series, 10"
HDJ3-M



Black River Series, 8"
HDJ3-S

NEW!

BLACK RIVER SERIES

HEADLINER® SERIES ROPE TUNED WOOD DJEMBES 1 2

SIZES S = 8" diameter, 15 3/4" tall
M = 10" diameter, 20" tall
L = 12" diameter, 24" tall
XL = 13" diameter, 25" tall

PP ROPES S = 4 mm thickness, 16 runners
M = 4 mm thickness, 18 runners
L = 5 mm thickness, 20 runners
XL = 6 mm thickness, 24 runners

1 NILE SERIES

The hand carved shells feature a gouged surface reminiscent of sun-dappled water. This texture makes the djembe easy to grip between the knees. Hand selected goat heads are secured by the traditional Mali-weave system and runners of pre-stretched nylon PP rope.

MATERIAL Mahogany Wood

FEATURES Carved from one solid piece of plantation grown Mahogany Wood
Hand selected goat heads
Pre-stretched nylon PP ropes
Hand carved shells

COLOUR Brown

2 BLACK RIVER SERIES

These Djembes are made from a solid piece of plantation grown Mahogany wood, and are hand carved with a horizontal ripple motif that suggests a flowing river. This also makes the djembe easy to grip between the knees. The hand selected goat skin head is secured and tuned with the traditional Mali Weave system.

MATERIAL Mahogany Wood

FEATURES Carved from one solid piece of plantation grown Mahogany Wood
Hand selected goat heads
Pre-stretched PP nylon ropes
Hand carved shells

COLOUR Black

3



Congo Series, 13"
HDJ1-XL



Congo Series, 12"
HDJ1-L



Congo Series, 10"
HDJ1-M



CONGO SERIES

DJEMBES

4



Tribal Series, 13"
HDJ2-XL



Tribal Series, 12"
HDJ2-L



Tribal Series, 10"
HDJ2-M

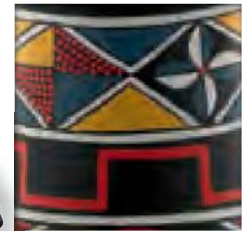

TRIBAL SERIES

HEADLINER® SERIES ROPE TUNED WOOD DJEMBES 3 4

SIZES M = 10" diameter, 20" tall
L = 12" diameter, 24" tall
XL = 13" diameter, 25" tall
PP ROPES M = 4 mm thickness, 18 runners
L = 5 mm thickness, 20 runners
XL = 6 mm thickness, 24 runners

3 CONGO SERIES

These djembes are carved from one solid piece of plantation grown Mahogany Wood and feature the traditional Mali Weave tuning system.

MATERIAL Mahogany Wood
FEATURES Carved from one solid piece of plantation grown Mahogany Wood
Hand selected goat heads
Pre-stretched PP nylon ropes
Hand carved shells
Ornamental carving

COLOUR Dark Brown

4 TRIBAL SERIES

The black Tribal Series are painted with an African style design and feature the traditional Mali Weave tuning system. The body is made out of one solid piece of Mahogany Wood.

MATERIAL Mahogany Wood
FEATURES Carved from one solid piece of plantation grown Mahogany Wood
Hand selected goat heads
Pre-stretched PP nylon ropes
Hand painted shells

COLOUR Black with tribal painting



**13", bundle with bag MDJB-M
ADJ2-XL+BAG**

**12", bundle with bag MDJB-M
ADJ2-L+BAG**

**10", bundle with bag MDJB-S
ADJ2-M+BAG**

ORIGINAL AFRICAN STYLE ROPE TUNED WOOD DJEMBES

These djembes are carved from one solid piece of plantation grown Mahogany Wood. These high quality instruments are crafted with great attention to detail and provide an outstanding, full-volume sound. We offer these drums in three different series: The Earth Rhythm Series features a carved design in black and brown. Its earthy pattern is evocative of ploughed fields and stalks of grain. The Moon Rhythm Series features a carved design in a dark mystic finish. The Water Rhythm Series features a carved design evocative of ocean waves, and all djembes come bundled with the Professional MEINL Djembe Bag.

- SIZES** M= 10" (9 1/4" – 10 1/4") diameter, 20" tall
L= 12" (10 3/4" – 12 1/4") diameter, 24" tall
XL= 13" (12 3/4" – 13 3/4") diameter, 25" tall
- HTP ROPES** M= 4 mm thickness, 25 runners
L= 4 mm thickness, 35 runners
XL= 5 mm thickness, 35 runners
- MATERIAL** Mahogany Wood
- FEATURES** Carved from one solid piece of plantation grown Mahogany Wood
Hand selected goat heads
Pre-stretched HTP nylon ropes
Hand carved shells
Ornamental carving
- INCLUDES** Professional Djembe Bag made out of heavy duty padded nylon

- COLOURS** ADJ2 = Brown
ADJ3 = Brown/Black
ADJ4 = Black

EARTH RHYTHM SERIES



13", bundle with bag MDJB-M
ADJ3-XL+BAG

12", bundle with bag MDJB-M
ADJ3-L+BAG

10", bundle with bag MDJB-S
ADJ3-M+BAG

MOON RHYTHM SERIES



13", bundle with bag MDJB-M
ADJ4-XL+BAG

12", bundle with bag MDJB-M
ADJ4-L+BAG

10", bundle with bag MDJB-S
ADJ4-M+BAG



4 MM PRE-STRETCHED HTP NYLON ROPES

1



"Village" carving, 12"
PROADJ2-L



SPECIAL "VILLAGE" CARVING

2



Brown, 12"
ABGB-L

INTRICATE CARVING

HAND SELECTED COW HEAD

3



Traditional style hewn, 12"
PROADJ1-L

TRADITIONAL STYLE HEWN

4



"African Queen" carving, 12"
PROADJ4-L

"AFRICAN QUEEN" CARVING

PROFESSIONAL AFRICAN STYLE DJEMBES

1 3 4

The MEINL Professional African Djembes are expertly hewn from a solid piece of plantation grown Mahogany Wood, and fitted with a hand selected goatskin head. We use the traditional Mali Weave tuning system with high quality HTP rope.

MATERIAL Mahogany Wood

COLOUR Brown

1 "VILLAGE" DJEMBE

SIZE L = 12" (10 3/4" – 12 1/4") diameter, 24" tall

HTP ROPE 4 mm thickness, 35 runners

FEATURES Carved from one solid piece of plantation grown Mahogany Wood
Hand selected goat heads
Pre-stretched HTP nylon rope

2 AFRICAN BOUGARABOU

The MEINL Bougarabou is proudly made in the tradition of the Jola people of southern Senegal. The classic bougarabou features an elongated goblet-shaped body carved from Mahogany Wood. A bougarabou can be played with traditional conga or djembe techniques, and makes a rich complement within drum ensembles.

SIZE L = 12" diameter, 24" tall

HTP ROPE 5 mm thickness, 22 runners

MATERIAL Mahogany Wood

FEATURES Carved from one solid piece of plantation grown Mahogany Wood
Hand selected cow head
Pre-stretched HTP nylon rope
Intricate carving

COLOUR Brown

3 PROFESSIONAL DJEMBE

SIZE L = 12" (10 3/4" – 12 1/4") diameter, 24" tall

HTP ROPE 4 mm thickness, 35 runners

FEATURES Carved from one solid piece of plantation grown Mahogany Wood
Hand selected goat heads
Pre-stretched HTP nylon rope
Traditional style hewn

4 "AFRICAN QUEEN" DJEMBE

SIZE L = 12" (10 3/4" – 12 1/4") diameter, 24" tall

HTP ROPE 4 mm thickness, 35 runners

FEATURES Carved from one solid piece of plantation grown Mahogany Wood
Hand selected goatskin head
Pre-stretched 4 mm HTP Nylon rope
Special "African Queen" carving

ARTISAN EDITION DJEMBE



DELUXE CARVING

DJEMBES



FOR MORE INFO, SCAN THIS MEINL QR CODE WITH YOUR SMARTPHONE

Rama Sita Deluxe, 14"
PROADJ3-XXL

CARVED FROM ONE SOLID PIECE OF PLANTATION GROWN MAHOGANY WOOD

ARTISAN EDITION DJEMBE

This Djembe is hand carved from a solid plantation grown Mahogany log, and exquisitely carved with figures from the Ramayama, the epic Hindu legend and love story of Rama and Sita. Each djembe is a work of art. We make sure it sounds as good as it looks with top quality hand-selected goat skin heads, and the best pre-stretched HTP rope. We cherish our Artisan Edition Djembes as a collectors item, and so will you.

- SIZE** XXL=14" (13 3/4" – 15 1/4") diameter, 26" tall
- HTP ROPES** XXL= 5 mm thickness, 40 runners
- MATERIAL** Mahogany Wood
- FEATURES** Carved from one solid piece of plantation grown Mahogany Wood
Hand selected goat heads
Pre-stretched HTP nylon rope
Deluxe carving
- COLOUR** Brown



PRINCE AKONGO, TOGO

1



Pharaoh's Script, 12"
FADJ1-L



Pharaoh's Script, 10"
FADJ1-M



PHARAOH'S SCRIPT

2



Kenyan Quilt, 12"
FADJ2-L



Kenyan Quilt, 10"
FADJ2-M

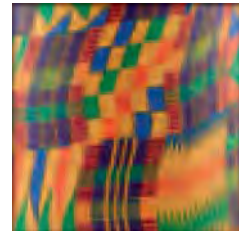

KENYAN QUILT



JOURNEY SERIES ROPE TUNED FIBERGLASS DJEMBES 1 2

SIZES M = 10" diameter, 18" tall
L = 12" diameter, 24" tall

MATERIALS Premium fiberglass
Synthetic head

FEATURES 100% synthetic is perfect for outdoor playing
Light weight fiberglass construction makes them easy to carry
Modern materials means they are unaffected by the weather
Pre-stretched PP nylon ropes

1 FADJ1 FIBERGLASS DJEMBES

This ultra light weatherproof djembes made from premium fiberglass are equipped with synthetic heads that produce the classic djembe sound – a fat bass to rich open tones and cutting slaps.

FINISH Pharaoh's Script

2 FADJ2 FIBERGLASS DJEMBES

The Journey Series Rope Tuned Djembes are the perfect instrument for drum circles and outdoor playing due to their light weight fiberglass construction. The use of modern materials means they are unaffected by the weather.

FINISH Kenyan Quilt



100% SYNTHETIC ARE PERFECT FOR OUTDOOR PLAYING

HEADLINER® SERIES DANCING PERCUSSION



YOEL PAEZ, SPAIN

1 IMPROVED!



Red, 8" x 11 1/4"
HFDD2R

2 NEW!



Red, 8" x 11 1/3"
HDJ200R

3 NEW!



Black, 8 1/2" x 24"
HC301BK

4 NEW!



Red, 12" x 22 3/4"
HDJ400R



DANY SCHNYDER, SWITZERLAND

The MEINL Headliner® Series Dancing Percussion are the perfect instruments for educational or street percussion. They are made from high quality materials and produce great sounds.

1 FIBERGLASS FAMILY DRUM

SIZE 8" diameter, 11 1/4" tall

MATERIAL Premium fiberglass

FEATURES Traditional rim
Black powder coated hardware

INCLUDES Nylon strap
Tuningkey

COLOUR R = Red

2 FIBERGLASS MINI DANCING DJEMBE

SIZE 8" diameter, 11 1/3" tall

MATERIAL Premium fiberglass

FEATURES Traditional rim
Black powder coated hardware
Floatune Tuning System

INCLUDES Nylon strap
Tuning key

COLOUR R = Red

3 FIBERGLASS DANCING CONGA

SIZE 8 1/2" diameter, 24" tall

MATERIAL Premium fiberglass

FEATURES 7 mm strong tuning lugs
2.2 mm rounded rim
Black powder coated hardware

INCLUDES Nylon strap
Tuning key

COLOUR BK = Black

4 FIBERGLASS DANCING DJEMBE

SIZE 12" diameter, 22 3/4" tall

MATERIAL Premium fiberglass

FEATURES 7 mm strong tuning lugs
2.2 mm rounded rim
Black powder coated hardware

INCLUDES Nylon strap
Tuning key

COLOUR R = Red



DONG KEXIN, CHINA



LORENZO GASPERONI, ITALY



BRYAN BROCK, USA

ROPE TUNED & HEADLINER® SERIES WOOD DJEMBES



African Brown, 12"
DJWR3AB-M



Vintage Wine Barrel, 12 1/2"
HDJ500VWB-M



Army Issue, 12"
HDJ600AI



Wine Red Burst, 12"
HDJ600WRB



Vintage Sunburst, 12"
HDJ600VSB



Natural, 12"
HDJ600NT

1 ROPE TUNED WOOD DJEMBE

This djembe is crafted with great attention to detail. It features the traditional rope tuning system. A great sounding drum at an affordable price.

SIZE 12" diameter, 24 1/4" tall

MATERIAL Rubber Wood
(*Hevea brasiliensis* Muell.-Arg.)

FEATURES True Skin Calf Head
Traditional rope tuning system

COLOUR AB-M = African Brown

FINISH Matte

2 4 HEADLINER® SERIES WOOD DJEMBES

The MEINL Headliner® Series Djembes have it all! Equipped with hand selected goat heads, they produce the classic djembe sounds reaching from fat basses to rich open tones and cutting slaps.

SIZES **HDJ500:** 12 1/2" diameter, 25 1/4" tall
HDJ600: 12" diameter, 23 1/2" tall

MATERIAL Rubber Wood
(*Hevea brasiliensis* Muell.-Arg.)

FEATURES 8 mm strong tuning lugs
2 mm rounded rims
Original MEINL style tuning brackets
Black powder coated hardware
Hand selected goat heads
HDJ500: Sleek Hourglass shape for more comfort

INCLUDES Tuning key

COLOURS NT = Natural, high gloss
VSB = Vintage Sunburst, high gloss
VWB-M = Vintage Wine Barrel, matte
WRB = Wine Red Burst, high gloss

3 HEADLINER® DESIGNER SERIES WOOD DJEMBE

This drum is a great all-around lug tuned djembe, perfect for drum circles and spontaneous jam sessions.

SIZE 12" diameter, 23 1/2" tall

MATERIAL Rubber Wood
(*Hevea brasiliensis* Muell.-Arg.)

FEATURES 8 mm strong tuning lugs
2 mm rounded rim
Original MEINL style tuning brackets
Black powder coated hardware
Hand selected goat head

INCLUDES Tuning key

COLOUR AI = Army Issue

FINISH Matte

1



Gold Amber Sunburst, 12 3/4"
DJW2GAB-M



Natural, 12 3/4"
DJW2NT



African Brown, 12 3/4"
DJW2AB-M

REPOSITIONED TUNING LUGS OFFER
PERFECT PLAYING COMFORT

2



Gold Amber Sunburst, 12"
DJW3GAB-M



Natural, 12"
DJW3NT



African Brown, 12"
DJW3AB-M

FLOATUNE TUNING AVOIDS THE NEED
TO DRILL THROUGH THE SHELL

FLOATUNE SERIES WOOD DJEMBES 1 2 3

The MEINL Floatune Djembes are modelled after the West African originals. Deep, round-sounding bass notes complimented by crisp tones and slaps are produced by this drum.

FEATURES True Skin Goat Heads
8 mm strong tuning lugs
3 mm rounded SSR-Rims
Easy tuning and comfortable change of heads
Rubber pads and lug placement offer perfect playing comfort
Floatune Tuning System
Chrome plated hardware

INCLUDES Accessory pouch
L-shaped tuning key
Tune Up Oil

COLOURS AB-M = African Brown, matte
GAB-M = Gold Amber Sunburst, matte
NT = Natural, high gloss
ZFA-M = Zebra Finished Ash, matte

1 FLOATUNE SERIES 12 3/4" WOOD DJEMBES

SIZE 12 3/4" diameter, 25 1/4" tall
MATERIAL Rubber Wood
(*Hevea brasiliensis* Muell.-Arg.)

2 FLOATUNE SERIES 12" WOOD DJEMBES

SIZE 12" diameter, 24 1/4" tall
MATERIAL Rubber Wood
(*Hevea brasiliensis* Muell.-Arg.)

3 FLOATUNE SERIES WOODCRAFT DJEMBE

SIZE 12" diameter, 24 1/4" tall
MATERIAL American White Ash
(*Fraxinus americana* L.)



INOR SOTOLONGO, FRANCE

3



FLOATUNE TUNING SYSTEM

Zebra Finished Ash, 12"
DJW3ZFA-M

4



SPARKLING EFFECT

Blue Sparkle, 12"
DJF3BSP



SPARKLING EFFECT

Red Sparkle, 12"
DJF3RSP

4 FLOATUNE SERIES FIBERGLASS DJEMBES

The MEINL Floatune Series Fiberglass Djembes are truly a sound alternative. Fiberglass has enormous strength and can produce slaps of outstanding clarity and immensely powerful bass tones.

SIZE 12" diameter, 24 1/4" tall

MATERIAL Premium fiberglass

FEATURES True Skin Goat Heads

8 mm strong tuning lugs

3 mm rounded SSR-Rims

Easy tuning and comfortable change of heads

Rubber pads and lug placement offer perfect playing comfort

Floatune Tuning System

Chrome plated hardware

INCLUDES Accessory pouch
L-shaped tuning key
Tune Up Oil

COLOURS BSP = Blue Sparkle
RSP = Red Sparkle



CHROME PLATED
3MM ROUNDED SSR RIMS



SPECIAL RUBBER PADS FOR
PERFECT PLAYING COMFORT



DARBUKAS DOUMBEKS

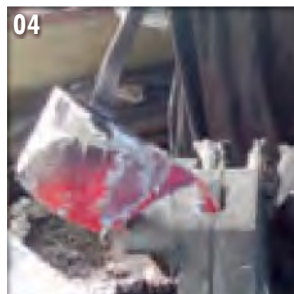

01 Aluminum is molten in a crucible, ready for casting.

02 These aluminum blanks will be spun into darbuka bodies.

03 Darburka body is here spun-formed on a lathe.

04 Molten aluminum is cast into a form.

05 Cast aluminum bodies and rims.

06 Rim is getting finished after casting.

07 Some designs are hammered by hand.

08 Some designs are engraved by mechanical burin.



HAMMERED BODY RECEIVES ITS POLISH

1



8" x 14 1/2"
HE-104



7 1/4" x 13 1/3"
HE-103



6 1/2" x 12 3/4"
HE-102



5 7/8" x 11"
HE-101



5 1/3" x 9 1/4"
HE-100

2 **NEW!**



8" x 14 1/2"
HE-124



6 1/2" x 12 3/4"
HE-122



HAND ENGRAVED SHELL

FOR MORE INFO, SCAN THIS MEINL
OR CODE WITH YOUR SMARTPHONE



JAVIER VILLAR MORALES, SPAIN

DARBUKAS

MEINL darbukas are made in the tradition of the original, esoteric goblet-shaped drums found in music from Eastern Europe, the Middle East and Southern Asia. Our darbukas are constructed from thin shells in various metals, each metal giving the different models their special timbre. The head is secured and tuned with external rings set close to the shell, in the Turkish-style. Light yet powerful, the darbukas have a deep full bass. They are well suited for high-pitched snapping sounds as well as a wide range of articulated "dum" and "tak" strokes.

1 ALUMINUM DARBUKAS, PLAIN

SIZES **HE-100:** 5 1/3" x 9 1/4"
HE-101: 5 7/8" x 11"
HE-102: 6 1/2" x 12 3/4"
HE-103: 7 1/4" x 13 1/3"
HE-104: 8" x 14 1/2"

MATERIAL Aluminum
FEATURE Synthetic heads
INCLUDES Tuning key

2 ALUMINUM DARBUKAS, HAND-ENGRAVED

SIZES **HE-122:** 6 1/2" x 12 3/4"
HE-124: 8" x 14 1/2"

MATERIAL Aluminum
FEATURES Synthetic heads
Hand engraved shells
INCLUDES Carrying bag
Spare head
Tuning key

3



BUILT IN JINGLES

8 1/4" x 16"
HE-315

8" x 14 1/2"
HE-314

4



HAND-HAMMERED ORNAMENT

8" x 14 1/2"
HE-114

7 1/4" x 13 1/3"
HE-113

5



BRASS PLATED AND HAND-HAMMERED SHELL

7 7/8" x 15 1/2"
HE-215

7 1/2" x 14 3/4"
HE-214

6



HAND ENGRAVED SHELL

NATURAL RAWHIDE HEAD

7 7/8" x 15 1/2"
HE-205

7 1/2" x 14 3/4"
HE-204

3 ALUMINUM JINGLE DARBUKAS, HAND-HAMMERED

SIZES **HE-314:** 8" x 14 1/2"
HE-315: 8 1/4" x 16"
MATERIAL Aluminum
FEATURES Built in jingles
Synthetic heads
Hand-hammered shells
INCLUDES Tuning key

4 ALUMINUM DARBUKAS, HAND-HAMMERED

SIZES **HE-113:** 7 1/4" x 13 1/3"
HE-114: 8" x 14 1/2"
MATERIAL Aluminum
FEATURES Synthetic heads
Hand-hammered shells
INCLUDES Tuning key

5 COPPER DARBUKAS, BRASS PLATED, HAND-HAMMERED

SIZES **HE-214:** 7 1/2" x 14 3/4"
HE-215: 7 7/8" x 15 1/2"
MATERIAL Copper
FEATURES Synthetic heads
Hand-hammered shells
INCLUDES Carrying bag
Spare head
Tuning key

6 COPPER DARBUKAS, HAND ENGRAVED

SIZES **HE-204:** 7 1/2" x 14 3/4"
HE-205: 7 7/8" x 15 1/2"
MATERIAL Copper
FEATURES Natural rawhides
Hand engraved shells
INCLUDES Carrying bag
Spare head
Tuning key

1



HAND CARVED ORNAMENTS

8" x 16"
ADB-L

7" x 12"
ADB-M

2

NEW!



PREMIUM FIBERGLASS

8 1/2" x 17 1/8"
FDB3000G

3



BLACK

8 1/2" x 17 1/8"
HE-3000



BEIGE

8 1/2" x 17 1/8"
HE-3000BG



COPPER

8 1/2" x 17 1/8"
HE-3020

1 WOOD DOUMBEKS

The MEINL Wood Doumbeks are great sounding, light weight wooden doumbeks with decorative tribal carving on the foot. Goatskin heads are securely fastened over the Egyptian style bearing rims, which is preferred for finger roll techniques.

SIZES M = 7" x 12"
L = 8" x 16"

MATERIAL Mahogany Wood

FEATURES Carved from one solid piece of plantation grown Mahogany Wood
Pre-tuned goat head
Comfortable rounded rim
Hand carved ornaments

COLOUR Brown

FINISH Matte

2 FIBERGLASS DOUMBEK

Our Fiberglass Doumbek has great sound properties and modern construction. Durable premium fiberglass shell bestows resonance and clarity. Crosshatched shell texture makes the doumbek easy to hold and resists slipping. Synthetic head holds tuning in all weather conditions.

SIZE 8 1/2" x 17 1/8"

MATERIAL Premium fiberglass

FEATURES Solid fiberglass construction
Synthetic head

COLOUR Gold

DOUMBEKS 3 4 5 6 7

SIZE 8 1/2" x 17 1/8"

INCLUDES Carrying bag, Spare head, Tuning key

3 ALUMINUM DOUMBEKS

Hand made entirely of aluminum, the MEINL Doumbek is outstanding in sound and quality, reaching from resonant lows to ringing highs. Available in three different finishes.

MATERIAL Aluminum

FEATURE Synthetic heads

COLOURS **HE-3000:** Black

HE-3000BG: Beige

HE-3020: Copper

4 ALUMINUM DOUMBEK, HAND ENGRAVED

This aluminum doumbek comes in a ornamental hand graving and produces snappy mid east sounds.

MATERIAL Aluminum

FEATURES Synthetic head
Hand engraved shell

4



HAND ENGRAVED SHELL

8 1/2" x 17 1/8"
HE-3018

5



HAND-HAMMERED SHELL

8 1/2" x 17 1/8"
HE-3030

6



WOOD COVERED SHELL

8 1/2" x 17 1/8"
HE-3400



SUAT BORAZAN, TURKEY

7



HAND ENGRAVED SHELL

8 1/2" x 17 1/8"
HE-3012

8



HEAVY WEIGHT FOR MORE PLAYING COMFORT

9" x 19"
HE-5000

5 ALUMINUM DOUMBEC, HAND-HAMMERED

The aluminum shell of this MEINL Doumbek is completely hand-hammered for a most appealing look.

- MATERIAL** Aluminum
- FEATURES** Synthetic head
Hand-hammered shell

6 ALUMINUM DOUMBEC, WOOD COVERED

The shell of this MEINL Doumbek is made from aluminum and is completely covered with a layer of the finest wood.

- MATERIAL** Aluminum
- FEATURES** Synthetic head
Wood covered shell

7 COPPER DOUMBEC, HAND ENGRAVED

The copper shell of this MEINL Doumbek is hand engraved for a stunning look. A very traditionally looking and sounding instrument.

- MATERIAL** Copper
- FEATURES** Synthetic head
Hand engraved shell

8 PROFESSIONAL DOUMBEC

We made our Professional Doumbek to meet the needs of the most demanding players. It's cast from solid aluminum and is larger and heavier than our regular models. The shell is extra thick for unparalleled clarity and projection.

- SIZE** 9" x 19"
- MATERIAL** Aluminum
- WEIGHT** 15.8 lbs (7200 g)
- FEATURES** Synthetic head
Heavy weight for more playing comfort
- INCLUDES** Professional carrying bag
Tuning key

TABLAS

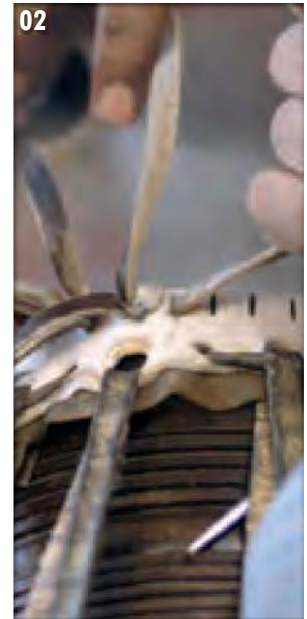

- 01** Preparing the head.
- 02** Mounting the head .
- 03** Preparing the syahi from different ingredients.
- 04** Making it look nice by using different kind of raw hides.
- 05** Putting the syahi on the dayan.
- 06** Cutting spare material of the damping layer.



ENGRAVING BEAUTIFUL ORNAMENTS ON THE BAYAN

TABLAS & ARTISAN EDITION TABLAS



1



Bayan, 8 1/2" & Dayan, 5 1/2"
TABLA

2



Bayan, 9" & Dayan, 5 1/2"
PRO-TABLA

TOP-OF-THE-LINE PROFESSIONAL TABLA SET!
MADE BY A MASTER CRAFTSMAN IN INDIA

1 TABLA SET

The MEINL Tabla is made in the time-honored Indian tradition. Proper tuning is achieved by adjusting wooden rollers that are fitted under the nylon verticals.

SIZES Dayan 5 1/2"
Bayan 8 1/2"

MATERIALS Chrome plated copper with goat skin
Rosewood with goat skin

FEATURES Authentic tabla heads
Nylon straps for longer durability

INCLUDES Padded support rings
Tuning hammer

2 ARTISAN EDITION TABLAS

A top-of-the-line professional quality tabla set. Our Artisan Edition Tablas are made according to their classical heritage, and are superbly crafted. The tones are unsurpassed for their clarity and character. These are tablas that will make any player proud.

SIZES Dayan 5 1/2"
Bayan 9"

MATERIALS Copper with goat skin
Mahogany with goat skin

FEATURES Top quality goat skin tabla heads
Traditional tuning system with rawhide thongs

INCLUDES Tuning hammer and wooden tuning dowel
Ring pads
Protective head covers



1



Iya, 6 3/4"
BA3BK

Itotele, 5 3/4"
BA2BK

Okonkolo, 5 1/4"
BA1BK



BILL SUMMERS, USA

2



NYLON TUNING STRAP

7 1/2"
TD7BK

3



9" x 20"
ATD-XL

8" x 16"
ATD-L

7" x 12"
ATD-M



COMES WITH A CURVED WOODEN BEATER

1 BATAS

The MEINL Batas are made from premium fiberglass for more durability, lighter weight and comfortable playing, and have a traditionally authentic sound.

SIZES Okonkolo 5 1/4" & 8",
Itotele 5 3/4" & 8 3/4"
Iya 6 3/4" & 12"

MATERIAL Premium fiberglass

FEATURES Hand selected buffalo heads
Traditional TTR-Rims

INCLUDES Nylon strap
Tuning key

COLOUR BK = Black

2 FIBERGLASS TALKING DRUM

The Talking Drum has its origin in West Africa. The traditional technique involves squeezing the tuning ropes while striking the head with a thin bent wooden mallet.

SIZE 7 1/2"

MATERIAL Premium fiberglass

FEATURES Durable synthetic heads
Wooden rims
Nylon tuning strap

INCLUDES Curved wooden beater

COLOUR BK = Black

3 AFRICAN WOOD TALKING DRUMS

Our African Talking Drums are carved into an hour-glass shape from a solid piece of Mahogany wood, and decorated with a carved motif. Two hand-selected

goatskin heads are spanned with high-quality nylon rope. Traditionally, the talking drum is played beneath one arm, and held against the ribcage. The drum is then squeezed to "bend" the pitch while the other hand employs a curved striker.

SIZES M=7" x 12", 23 rope runners, 3 mm PP rope
L=8" x 16", 28 rope runners, 3 mm PP rope
XL=9" x 20", 34 rope runners, 3 mm PP rope

MATERIALS Mahogany Wood

Hand selected goat heads

FEATURES Carved from one solid piece of plantation grown Mahogany Wood
Nylon tuning strap
Ornamental carving

INCLUDES Curved wooden beater

FINISH Brown/Black

RITUAL DRUMS



CARLO MARZO, ITALY

1



TRUE SKIN BUFFALO HEADS



11"
MTA1SNT-M

2



HEAVY DUTY STAND CAN BE TILTED

8" & 9"
HCG89NT

3



TRADITIONAL ROPE TUNING SYSTEM

7"
RAMWONG7

1 TAMBORA

The rhythm of the Merengue has its roots in the Dominican Republic where the use of a Tambora drum is essential in creating this style of music.

SIZE 11"

MATERIAL Rubber Wood
(*Hevea brasiliensis* Muell.-Arg.)

FEATURES True Skin Buffalo Heads
Black powder coated hardware

INCLUDES Nylon strap
Wooden beaters
Tuning key

COLOUR SNT-M = Super Natural
FINISH Matte

2 WOOD CONGUITAS

The Conguitas are a perfect addition to any percussion set up. They are made from high quality materials and produce a cutting and strong percussive tone which complements the congas in a harmonically supportive sound spectrum.

SIZES 8" & 9"

MATERIAL Rubber Wood
(*Hevea brasiliensis* Muell.-Arg.)

FEATURES 8 mm strong tuning lugs
Original MEINL style tuning brackets
Traditional rims

Black powder coated hardware
Hand selected buffalo heads

INCLUDES Height adjustable tilting double braced tripod stand
Tuning key
Wrench

COLOUR NT = Natural
FINISH High gloss

3 RAMWONG

Ramwong is a Thai folk dance which evolved from Ramthone, a popular festive season in a certain region in Thailand. Ram means dance and Thone is a small drum.

SIZE 7" diameter, 10" tall

MATERIAL Wood

FEATURES Natural rawhide
Traditional rope tuning system



TAKU HIRANO, USA



JORGE JOSE BERMUDEZ, USA



ZHANG HONGCHUN, CHINA



MAX KLAAS, GERMANY

RITUAL DRUMS SHEKERES & BERIMBAU

1



Jumbo
SH2VSB

Medium
SH1BK

Medium
SH-R

SMALL NECK FOR MORE PLAYING COMFORT

2



DADO SEZZI, ITALY

RITUAL DRUMS



JOSÉ J. CORTIJO, GERMANY



BE1R

FOR MORE INFO, SCAN THIS MEINL QR CODE WITH YOUR SMARTPHONE



1 SHEKERES

MEINL shekeres are handmade from premium fiberglass and fitted with a net of beads. They deliver a crisp sound and unlike gourd shekeres, they are nearly unbreakable.

SIZES **SH-R:** Medium

SH1BK: Medium

SH2VSB: Jumbo

MATERIAL Premium fiberglass

COLOURS BK = Black

VSB = Vintage Sunburst

R = Red

2 BERIMBAU

The MEINL Berimbau is traditional African instrument that is commonly found in the music from Brazil and other South American countries. The thin striker and a caxixi are held in the right hand, while the left hand supports the bow and modulates the string with a small metal disc. The whole instrument is moved on-and-on the abdomen, opening and closing the resonant gourd, for a captivating "wah-wah" effect.

MATERIAL Premium fiberglass

INCLUDES Small Caxixi

Metal plate

Wooden stick

Carrying bag

COLOUR R = Red



1



ID2BKR

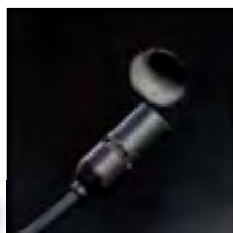

BUILT IN MICROPHONE HOLE

2



ID1BKR



LUIS RIBEIRO, AUSTRIA

1 FIBERGLASS IBO DRUM, LONG NECK

The Fiberglass Ibo Drum with long neck has a wide variety of different sounds and the fiberglass body makes it nearly unbreakable.

- SIZE** Long neck
- MATERIAL** Premium fiberglass
- FEATURES** Built in microphone hole
Resistant shell construction
- INCLUDES** Foam padded base
- COLOUR** BKR = Black/Red

2 FIBERGLASS IBO DRUM

This Ibo Drum has a wide variety of different sounds and the fiberglass body makes it nearly unbreakable.

- SIZE** Large
- MATERIAL** Premium fiberglass

- FEATURES** Built in microphone hole
Resistant shell construction
- INCLUDES** Foam padded base
- COLOUR** BKR = Black/Red

3 HEADED FIBERGLASS TRI SOUND IBO DRUM

This unique Ibo Drum features an additional rawhide playing surface and an extra thin bottom for enhanced sound.

- SIZE** Large
- MATERIAL** Premium fiberglass
- FEATURES** Rawhide playing surface
Built in microphone hole
Resistant shell construction
- INCLUDES** Foam padded base
- COLOUR** GO = Gold Ornament

4 FIBERGLASS TRI SOUND IBO DRUM

The regular Tri Sound Ibo Drum features an additional fiberglass playing surface and an extra thin bottom for enhanced sound.

- SIZE** Large
- MATERIAL** Premium fiberglass
- FEATURES** Extra fiberglass playing surface
Built in microphone hole
Resistant shell construction
- INCLUDES** Foam padded base
- COLOUR** BKO = Black Ornament



3 RAWHIDE PLAYING SURFACE

ID3GO



4 EXTRA FIBREGLASS PLAYING SURFACE

ID4BKO



5 HAND CARVED BODY

ID6



ID7RB



7 EXTRA FIBREGLASS BOTTOM FOR MORE SOUND OPTIONS

ID8RB



8 FOR MORE INFO, SCAN THIS MEINL QR CODE WITH YOUR SMARTPHONE

THE FIBREGLASS LIQUID IBO DRUM IS FILLED WITH WATER

ID9BK/WH

5 WOOD IBO DRUM
 The wooden body ensures a wide sonic range. Most suitable for studio and recording sessions.

SIZE Large
MATERIAL Made from Mango Wood (*Mangifera Sp.L.*)
FEATURES Dry tones
 Built in microphone hole
INCLUDES Foam padded base

6 CERAMIC IBO DRUM
 The ceramic body of this Ibo Drum causes a slight enhancement of the higher frequencies, with fat and powerful bass tones.

SIZE Large
MATERIAL Ceramic

FEATURES Full and rich sounds
 Built in microphone hole
INCLUDES Foam padded base
COLOUR RB = Red/Brown

7 CERAMIC IBO DRUM, FIBREGLASS BOTTOM
 The special feature of this MEINL Ceramic Ibo Drum is the fiberglass bottom for extra sound options.

SIZE Large
MATERIAL Ceramic
FEATURES Fiberglass playing surface
 Built in microphone hole
INCLUDES Foam padded base
COLOUR RB = Red/Brown

8 FIBREGLASS LIQUID IBO DRUM
 A sealed metal chamber containing water is permanently bonded to the premium fiberglass body. The liquid chamber adds fluctuating overtones to the drum's fundamentals. It's easy and it's fascinating! The liquid fluctuations give you new sounds at every turn of the hands.

SIZE Large
MATERIAL Premium fiberglass
FEATURES Special bottom, filled with water
 Built-in microphone hole
 Resistant shell construction
INCLUDES Foam padded base
COLOUR BK/WH = Black/White

CAJONS

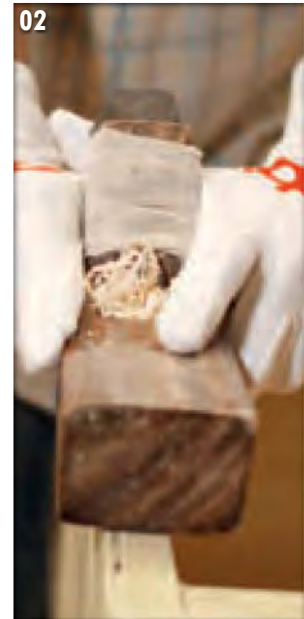
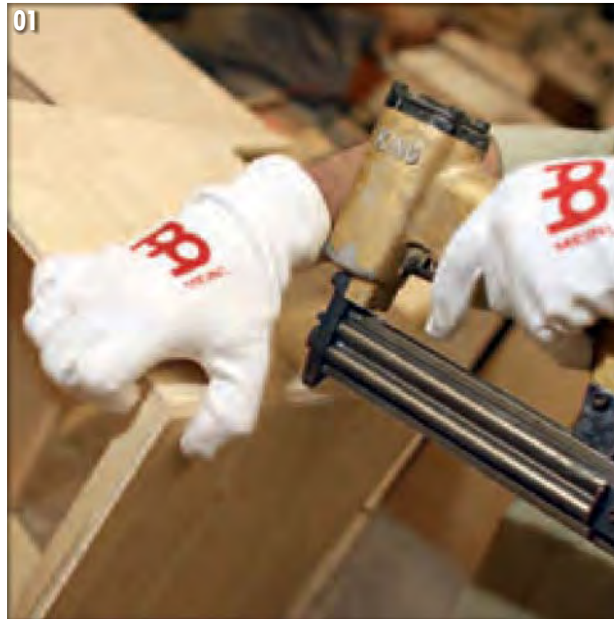

01 MEINL cajons are constructed with a combination of gluing and nailing techniques.

02 The cajon body is planed by hand. This creates the optimal contact between the faceplate and the body.

03 The sound hole is cut out of the back plate.

04 The sides and edges are carefully sanded.

05 The adjustable sizzle strings are positioned behind the frontplate. Here you see the tuning screws on the bottom of the cajon.

06 Our proprietary snare mechanism with foot pedal is being installed. Here you see the return spring being connected.

07 Here you see a Bubinga faceplate being fastened with screws.

08 MEINL cajons are securely packed for safe transport to distributors and dealers all over the world.

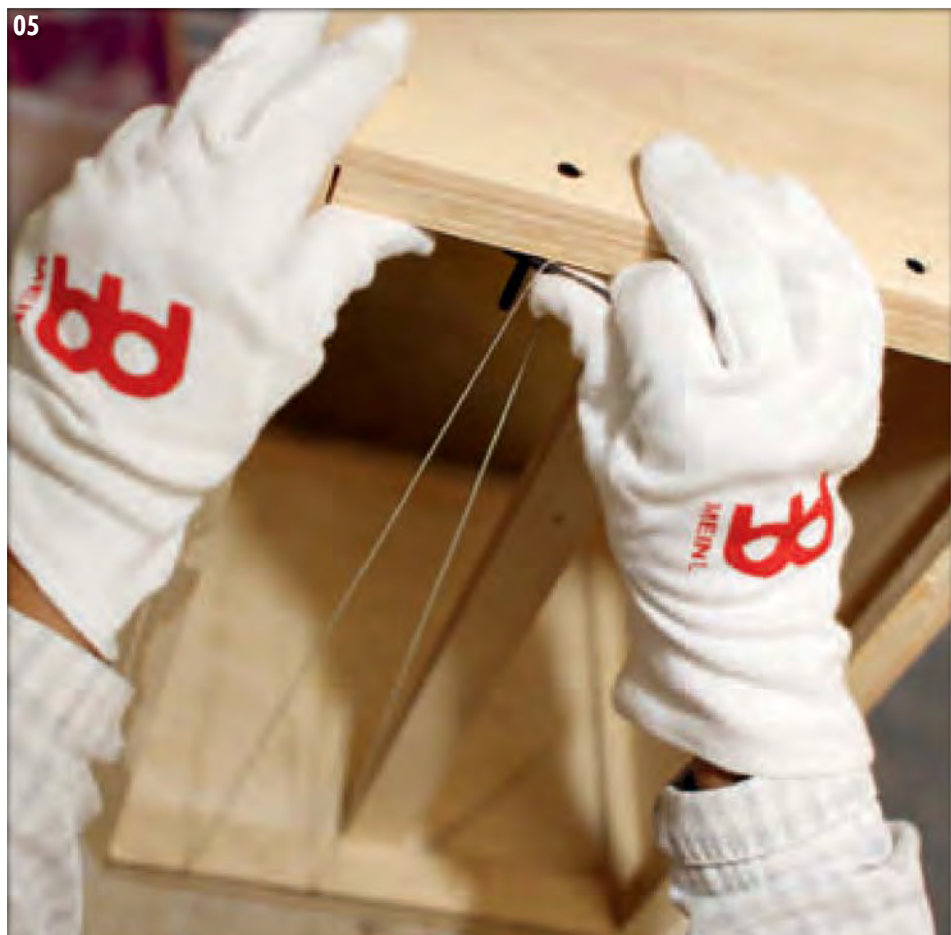



THE PARTS ARE MEASURED AND MARKED FOR DRILLING



1



Rubber Wood
HCAJ1NT



Rubber Wood
HCAJ3NT



Rubber Wood
HCAJ5NT

2

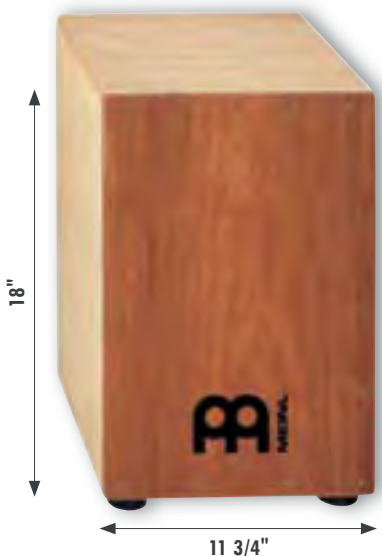

Mahogany
HCAJ1MH-M



Mahogany
HCAJ3MH-M

NEW!



ANNA TORNQVIST, SWEDEN

1 2 3 HEADLINER® SERIES CAJONS

The MEINL Headliner® Series Cajons deliver the classic cajon sound at an affordable price and can be used in Flamenco or World Music. They are also very useful during unplugged gigs for delivering the rhythmic foundation for a whole band when a full drum set can't be used.

- SIZES** **HCAJ1:** 11 3/4" W x 18" H x 11 3/4" D
HCAJ3: 11 3/4" W x 19 3/4" H x 11 3/4" D
HCAJ5: 13 1/4" W x 19 3/4" H x 13 3/4" D

MATERIALS HCAJ1AWA

Frontplate: Stained American White Ash (*Fraxinus Americana* L.)
 Resonating body: Eco-friendly medium density fiberboard
HCAJ1MH-M / HCAJ3MH-M
 Frontplate: Mahogany

FEATURES

- Resonating body: Rubber Wood (*Hevea brasiliensis* Muell.-Arg.)
- HCAJ1NT / HCAJ3NT / HCAJ5NT**
- Frontplate: Rubber Wood (*Hevea brasiliensis* Muell.-Arg.)
- Resonating body: Rubber Wood (*Hevea brasiliensis* Muell.-Arg.)
- Adjustable top corners
- Adjustable sizzle effect
- Anti-slip sitting surface
- Wide sound options
- HCAJ5NT:** Full bass spectrum

INCLUDES

- Allen wrench

FINISH

- Matte

ADJUSTABLE SIZZLE EFFECT



ANTI-SLIP SITTING SURFACE

HEADLINER® DESIGNER SERIES CAJONS

3



ECO-FRIENDLY MEDIUM DENSITY FIBERBOARD

Stained American White Ash
HCAJ1AWA



RAY LUZIER, USA

CAJONS

4



White Dragon
HCAJ2-WD



Original Camo
HCAJ2-OC



Skulls Finish
HCAJ2-SK

ECO-FRIENDLY MEDIUM DENSITY FIBERBOARD WITH APPLIQUE GRAPHICS

4 HEADLINER® DESIGNER SERIES CAJONS

The MEINL Headliner® Designer Series Cajons are available in three different motifs. The cloth-covered Original Camo model produces a drier and crisper sound compared to conventional bare wood construction, while the other two cajons are made out of eco-friendly medium density fiberboard with appliqué graphics.

MATERIALS HCAJ2-WD / HCAJ2-SK

Eco-friendly medium density fiberboard with appliqué graphics

HCAJ2-OC

Cloth-covered eco-friendly medium density fiberboard

FEATURES Snappy graphic style
Internal snare wires
Adjustable top corners

DESIGNS OC = Original Camo
SK = Skulls Finish
WD = White Dragon



HEAVY DUTY RUBBER FEET FOR A SOLID BASE

ADJUSTABLE TOP CORNERS

1



Makah-Burl
CAJ3MB-M

FOR MORE INFO, SCAN THIS MEINL QR CODE WITH YOUR SMARTPHONE



Black Makah-Burl
CAJ3BMB-M



Premium fiberglass
CAJ7NT-BK

ADJUSTABLE TOP CORNERS

2



American White Ash
CAJ3AWA

NEW!



Graphic Art Finish
CAJ3GAF



Willow Art Finish
CAJ3WAF

1 STRING CAJONS (US PATENT)

MEINL Cajons feature a built in adjustable sizzle effect. Strings, which touch the frontplate on the inside and span from top to bottom, deliver a sensitive rattle that can be adjusted to fit various musical applications. The patented integrated string mute system controls the tension of the strings and ensures a dry and crisp sizzle effect.

MATERIALS Resonating body: Rubber Wood (*Hevea brasiliensis* Muell.-Arg.),

CAJ3MB-M

Frontplate: Makah-Burl

CAJ3BMB-M

Frontplate: Black Makah-Burl

CAJ7NT-BK

Frontplate : Premium fiberglass

FEATURES

Adjustable top corners
Adjustable sizzle effect
Integrated string mute system (US patent)
Wide sound options
Padded sitting surface

INCLUDES

Allen wrench

FINISH

Matte

CAJ3AWA

Resonating body: PVC covered eco-friendly medium density fiberboard
Frontplate: American White Ash (*Fraxinus Americana* L.)

2 STRING DESIGNER SERIES CAJONS (US PATENT)

String Designer Series Cajons have a fresh and stylish appeal. Organic, fluid graphics take our cajons away from the "boxy-crate" look, and move them towards elegance.

MATERIALS Frontplate: Tulip Wood (*Dalbergia variabilis*)

Resonating body: Eco-friendly medium

density fiberboard with appliqué graphics

FEATURES

Stylish graphic designs

Adjustable top corners

Adjustable sizzle effect with integrated

string mute system (US patent)

Padded sitting surface

Wide sound options

INCLUDES

Allen wrench

DESIGNS

GAF = Graphic Art Finish

WAF = Willow Art Finish

3



Bundle with MCJB
CAJ3MB-M+BAG



Bundle with MCJB
CAJ3BMB-M+BAG



Bundle with MCJB
CAJ7NT-BK+BAG

BUNDLED WITH BAG



JOANNIE LABELLE, CANADA

4



Bubinga
CAJ300BU-M



ERGO-SHAPE (PATENTED)

3 STRING CAJONS BUNDLE WITH BAG (US PATENT)

4 ERGO-SHAPE STRING CAJON (PATENTED)

The MEINL Ergo-Shape String Cajon features an exotic Bubinga frontplate and two innovations: The frontplate is ergonomically curved for maximum comfort and sound development, and the string mute system gives your sound extra precision and control. The Bubinga frontplate is a rich and beautiful reddish coloured African wood.

- MATERIALS** Frontplate: Bubinga
Resonating Body: Rubber Wood (*Hevea brasiliensis* Muell.-Arg.)
- FEATURES** Ergo-Shape (CN, DE, US patent)
Adjustable sizzle effect
Integrated string mute system (US patent)
Adjustable top corners
Padded sitting surface
- INCLUDES** Allen wrench
- FINISH** Matte



ADJUSTABLE SIZZLE EFFECT WITH INTEGRATED STRING MUTE SYSTEM (US PATENT)



1 SNARE CAJONS

The snares touch the frontplate from the inside and deliver the classical cajon sound, which is requisite in Flamenco music. A knurled knob adjusts the amount of pressure used to press the snare wires against the frontplate.

MATERIALS CAJ1CA-M

Frontplate: Premium fiberglass
Resonating body: Rubber Wood (*Hevea brasiliensis* Muell.-Arg.)

CAJ1EB-M

Frontplate: Ebony
Resonating body: Rubber Wood (*Hevea brasiliensis* Muell.-Arg.)

CAJ1SNT-M

Frontplate: American White Ash (*Fraxinus americana* L.)

Resonating body: Rubber Wood (*Hevea brasiliensis* Muell.-Arg.)

FEATURES

Adjustable top corners
Internal, adjustable snare wires
Padded sitting surface
Wide sound options

FINISH

Matte

2 COLLECTION CAJON

The MEINL Collection Cajon features elegant veneers, both for the frontplate, and for the resonating body.

MATERIALS

Frontplate: Cherry
Resonating body: Red Oak (*Quercus rubra*)

FEATURES

Adjustable top corners
Internal, adjustable snare wires
Padded sitting surface

FINISH

Matte

3 TURBO CAJON (US PATENT)

Our Turbo Cajon goes an extra step towards cutting edge. We made this cajon with upper corners that have deeply cut channels with castanet-like striking surfaces.

MATERIAL

Frontplate and resonating Body:
Red Oak (*Quercus rubra*)

FEATURES

Castanet-like striking surface (US patent)
Internal snare wires
Wide sound options
Padded sitting surface

FINISH

Matte

PEDAL & PICKUP CAJONS

1



Bubinga
CAJ100BU-M

2



Ebony
CAJ5EB-M

FOOT PEDAL FOR A QUICK ON/OFF SWITCH OF THE SNARE WIRES (US PATENT)

3



American White Ash
CAJ9SNT-M



Makah-Burl
CAJ8MB-M

ACTIVE PRE-AMP SYSTEM WITH VOLUME CONTROL FROM *Shadow*

PEDAL CAJONS 1 2

A pedal attached to the cajon adjusts the amount of pressure used to press the snare wires against the front plate, and can even be turned off completely.

MATERIAL Resonating Body: Rubber Wood (*Hevea brasiliensis* Muell.-Arg.)

FEATURES Foot pedal (US patent)
Internal adjustable snare wires
Adjustable top corners
Padded sitting surface

FINISH Matte

1 ERGO-SHAPE PEDAL CAJON (PATENTED)

MATERIAL Frontplate: Bubinga
FEATURES Ergo-Shape (CN, DE, US patent)
Foot pedal (US patent)

2 BASS PEDAL CAJON (US PATENT)

MATERIAL Frontplate: Ebony
FEATURES Great bass tones
Wide sound options
Foot pedal (US patent)

3 PICKUP CAJONS

The MEINL Pickup Cajons are equipped with a pickup microphone and a pre-amp system with volume control from Shadow®. This active system includes a specially designed pre-amp, high quality endpin output jack and a durable battery.

MATERIALS Resonating body: Rubber Wood (*Hevea brasiliensis* Muell.-Arg.)
CAJ9SNT-M
Frontplate: American White Ash (*Fraxinus americana* L.)

CAJ8MB-M

FEATURES Frontplate: Makah-Burl
Pickup microphone
Active pre-amp system with volume control from Shadow®
Adjustable top corners
Padded sitting surface
Wide sound options
CAJ9SNT-M
Internal, adjustable snare wires
CAJ8MB-M
Adjustable sizzle effect with integrated string mute system (US patent)
INCLUDES 9-volt battery
CAJ8MB-M
Allen wrench
FINISH Matte

ARTISAN EDITION CAJONS



01 Each Artisan Edition Cajon is branded with a hot iron press.

02 Special in cuts are contoured and sanded.

03 A Seguriya Line cajon receives its decorative wood inlay.

04 Surfaces are finely polished.

05 Uncompromising attention to detail brings the ultimate results.



SNARE WIRES ARE HAMMERED INTO GROOVES CUT INTO THE CAJON BODY.



**Soleá Line
AE-CAJ3**

SPECIAL HAMMER TONE FINISH FOR BETTER FEEL AND GRIP



**Bulería Line
AE-CAJ5**

UNCOMPROMISING CRAFTSMANSHIP



**Seguiriya Line
AE-CAJ7**

ERGONOMICALLY CURVED AND ROUNDED FRONTPLATE WITH CONCAVE CONTACT

ARTISAN EDITION CAJONS 1 2 3

MEINL Artisan Edition Cajons are hand made in Spain with uncompromising craftsmanship for the most discerning of players. They are the finest cajons available on the market.

1 ARTISAN EDITION CAJON / SOLEÁ LINE

MATERIALS Frontplate: Cedar in Espresso Burst
Resonating body: 9 layer Birch Wood (*Betula pendula*)

FEATURES 10 pre-tuned upright strings
Ergonomically rounded frontplate with convex contact
Specially formulated rubber feet
Internal Bass Filter for sound compression
Distinguished heat branding

FINISH Satin

2 ARTISAN EDITION CAJON / BULERÍA LINE

MATERIALS Frontplate: Lava-Burl
Resonating body: 9 layer of Birch Wood (*Betula pendula*)

FEATURES Double 5-string tuneable snare arrays
Ergonomically rounded frontplate with convex contact
Specially formulated rubber feet
Internal Bass Filter for sound compression
Distinguished heat branding

INCLUDES Tuning key

FINISH Satin

3 ARTISAN EDITION CAJON / SEGUIRIYA LINE

MATERIALS Frontplate: Canyon-Burl
Resonating body: 11 layer Birch Wood (*Betula pendula*)

FEATURES 16 adjustable, vertical strings
Ergonomically curved and rounded frontplate with concave contact
Specially formulated soft rubber feet
Extra sound port ring for compression
Decorative wood inlay
Distinguished heat branding

INCLUDES Tuning key

FINISH Satin

1 NEW!



American White Ash
SUBCAJIAWA

SUPER LOW FREQUENCY

2 NEW!



Makah-Burl
TOPCAJIMB

COMFORT DESIGN
FOR A MORE UPRIGHT
PLAYING STYLE



MICHAEL BUCHNER: INVENTOR OF PROFESSIONAL BONGO CAJON, SLAP-TOP CAJON AND SUBWOOFER CAJON

3



Ebony
TRECAJ2EB-M



INVENTOR: AREND
SCHMIDT-LANDMEIER



ANGLED FRONTPLATE FOR
MORE PLAYING COMFORT

1 SUBWOOFER CAJON

The MEINL Subwoofer Cajon features a forward projecting sound port in place of the traditional rear facing style and an internal reflex channel. This results in an enhanced bass note projection, particularly desirable for live and unplugged situations.

MATERIALS Resonating body: Eco-friendly medium density fibreboard

Frontplate: American White Ash (*Fraxinus Americana* L.)

FEATURES Super low frequency
Forward projecting sound port
Internal snare wires
Adjustable top corners

FINISH Matte

2 SLAP-TOP CAJON

The MEINL Slap Top Cajon is a conceptual step up to a new level. This model is designed to bring the striking surface up nearer to the player, for a more upright playing style. The sound projects forward into the audience! High and low tones as well as a snare effect are built in to the sound board.

MATERIALS Resonating body: Eco-friendly medium density fibreboard

Frontplate: Makah-Burl

FEATURES Comfortable design
Forward sound projection
Internal snare wires
Wide sound spectrum

3 TREJON

The Trejon is similar to a drum set in that bass, snare, and tom sounds are in easy reach on the comfortably angled playing surface.

MATERIALS Frontplate: Ebony
Resonating Body: Rubber Wood (*Hevea brasiliensis* Muell.-Arg.)

FEATURES Angled playing surface
Two internal snare wires
Adjustable top corners
Padded sitting surface

4 PROFESSIONAL BONGO CAJON

5 BONGO CAJONS

The MEINL Snare Bongo Cajon can be played like a bongo, between the legs, or on one's lap. The professional version has a forward sound projection.

4

FORWARD
SOUND PROJECTION

Natural/Ebony Black, 7" & 8 1/2"
PBCA1NT/EBK-M

6



ADJUSTABLE SIZZLE EFFECT

Makah-Burl
PLCA1MB-M

5

INTERNAL
SNARE WIRESTWO DIFFERENT SIZED CHAMBERS
ENABLE AN AUTHENTIC BONGO EFFECT

Natural/Ebony Black
BCA2NT/EBK-M

Super Natural
BCA1SNT-M

7

FOR MORE INFO, SCAN THIS MEINL
QR CODE WITH YOUR SMARTPHONE

Natural
CCA1NT

8

NEW!

Black
TCAJ1BK

BACK



RAMESH SHOTHAM, INDIA/GERMANY

FOR MORE INFO, SCAN THIS MEINL
QR CODE WITH YOUR SMARTPHONE

MATERIAL Rubber Wood
(*Hevea brasiliensis* Muell.-Arg.)

FEATURES High- and low pitch playing surface
Compact size and light weight
BCA2NT/EBK-M: Internal snare wires
PBCA1NT/EBK-M: (patent pending)
High and low striking surfaces
Forward sound projection
Comfortable design

COLOURS NT/EBK-M = Natural/Ebony Black
SNT-M = Super Natural

6 PALITO

Strings which touch the playing surface on the inside deliver a sensitive sizzle effect that fits to various musical applications.

MATERIALS Playing surface: Makah-Burl

Resonating body: Rubber Wood
(*Hevea brasiliensis* Muell.-Arg.)

FEATURES Adjustable sizzle effect
Compact size

INCLUDES Allen wrench

7 CAJITA

The MEINL Cajita is developed from the classic Peruvian folk instrument. It hangs from the neck and is played with a wooden striker in one hand. The other hand controls the handle on the lid.

MATERIAL Rubber Wood
(*Hevea brasiliensis* Muell.-Arg.)

FEATURES Soft nylon cord
Solid piano hinge
Easy-grip handle

INCLUDES Wooden striker

8 TRAVEL CAJON

The MEINL Travel Cajon is a great way to practice cajon techniques while on the go or when you need to keep the volume way down. It is perfect for keeping your chops in shape, any time, anywhere!

SIZE 11 3/4"

MATERIAL Rubber Wood
(*Hevea brasiliensis* Muell.-Arg.)

FEATURES Internal snare wires
Compact design
Sound port for clear sound projection
Great way to practice cajon techniques while on the go

COLOUR BK = Black

FINISH Matte

1 **NEW!**



INVENTOR: MICHAEL BUCHNER



Black
WSS1BK

2 **NEW!**



Medium
WJC1-M

3



FOR MORE INFO, SCAN THIS MEINL QR CODE WITH YOUR SMARTPHONE



Small
WC1-S

Medium
WC1-M

Large
WC1-L



ADD NEW SOUNDS TO YOUR CAJON

1 WOOD SIDE SNARE

The Wood Side Snare for cajons takes your sound up to another level. Self-adhesive tape securely holds the ergonomically shaped box to any side of the Cajon. The player decides the perfect spot. It can be removed as desired.

MATERIAL Rubber Wood
(*Hevea brasiliensis* Muell.-Arg.)

FEATURES Internal snare effect
Hook and loop fastener attaches to Cajon body
Ergonomic shape
Unobtrusive low profile

COLOUR BK = Black

FINISH Matte

2 CAJON JINGLE CASTANET

The MEINL Cajon Jingle Castanet adds another accent to the Cajon. A pair of steel jingles gives a light metallic touch to the fundamental wooden Castanet. Various finger techniques produce changeable sounds. Like all our Cajon Castanets, self-adhesive tape application means they go easily on your cajon, or anywhere else.

SIZE Medium
MATERIALS Rubber Wood
(*Hevea brasiliensis* Muell.-Arg.)
Steel jingles

FEATURES Spring-opened
Hook and loop fastener goes on any surface

COLOUR BK = Black

FINISH Matte

3 CAJON CASTANETS

Our lightweight Castanets come in three sizes, and with hook and loop fastener. Stick them anywhere to add new colours to your cajon or any other instrument!

SIZES Small
Medium
Large

MATERIAL Rubber Wood
(*Hevea brasiliensis* Muell.-Arg.)

FEATURES Spring-opened
Hook and loop fastener goes on any surface

COLOUR BK = Black

FINISH Matte

SPECIALS FOOT PERCUSSION



HOLGER MERTIN, GERMANY

SOUNDS

- 0 - Kick Bass
- 1 - Cyber Kick
- 2 - Tribal Bass
- 3 - Straight Tambourine
- 4 - Double Tambourine
- 5 - Clave
- 6 - Hand Clap
- 7 - Dry Cowbell
- 8 - Straight Cabasa
- 9 - Double Cabasa



10 sound options
FX10



FRONT VIEW

A WHOLE PERCUSSION KIT IN A BOX



INVENTOR: TORSTEN FRANZ



Additional springs with more tension
SPARE-20

Large
FCA5-L

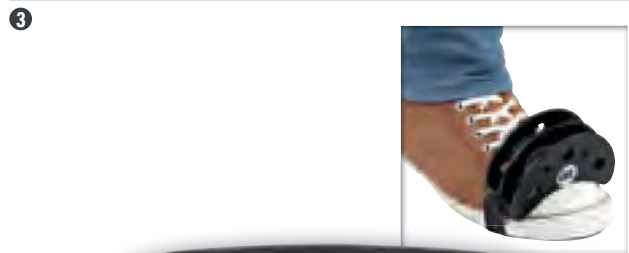

Stainless steel
FJS2S-BK

1 FX PEDAL

The MEINL FX Pedal features 10 different sound options that you can add to your beat. Cycle through the effects with a touch of the toe button. It's a whole percussion kit in a box! Plug in and groove...

MATERIALS Oak (Quercus (robur) pedunculata) and steel box

FEATURES Microprocessor controls
10 different sound options
Sound select button
Stereo/Mono output
Made in Germany by Shadow

INCLUDES Velcro with spikes
International power converter

2 FOOT CABASA (US PATENT)

The MEINL Foot Cabasa is a breakthrough instrument for the percussionist! We mounted a large Turbo Cabasa on our sturdy foot pedal (US patent), which adds a new sound to your setup. Keep a cabasa rhythm while your hands play the congas or other drums! The MEINL Foot Cabasa can be set for either a single or double-stroke, according to your taste.

SIZE Large
MATERIALS Steel chain and stainless steel cylinder
Wooden body
Black powder coated pedal

FEATURES Optional single or double-stroke setting
5 sound ports on each side for more volume (DE, US patent)

INCLUDES Drum key
Foot pedal

3 FOOT TAMBOURINE

The Foot Tambourine is a perfect compliment for virtually any instrument. It's light and versatile, yet not overpowering, delivering a sensitive accompaniment. Easily mounted on your foot, it will go with any beat.

MATERIALS Stainless steel
Rubber Wood
(*Hevea brasiliensis* Muell.-Arg.)

FEATURES Bright, light accent for any instrument
Ergonomic design
Hassle-free mounting

COLOUR BK = Black

TIMBALES



01 The round shape is carefully clamped on a jig in preparation for welding.

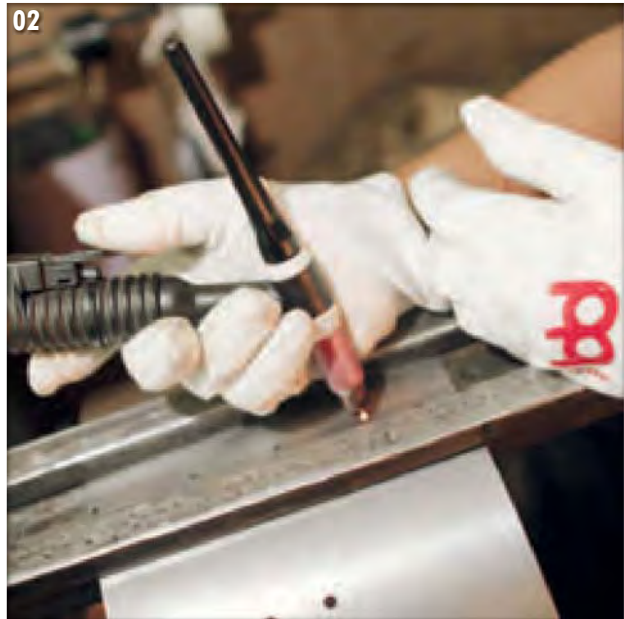

02 The first tack welds make it into a raw drum body.

03 Rollers form the body flanges, which are important for stability and a proper dry Cascara sound.



04 The MEINL Luis Conte Signature Timbales have a hammered texture. This is applied before the body is rolled into shape.



05 Here you see raw components for the Luis Conte Signature Timbales. The freshly cast mounting brackets will be cut free and individually polished. In the background, note the heavily hammered texture in the center portion of the shell stock.



THE FINISHED SHELLS ARE FITTED WITH HEADS, RIMS, AND HARDWARE.

HEADLINER® & MARATHON® SERIES TIMBALES

1



Chrome, 13" & 14"
HT1314CH

DRUM KIT
STYLE TUNING

2



Chrome, 14" & 15"
MT1415CH

3



Brass, 14" & 15"
MT1415B

HEAVY DUTY
STYLE BRACKETS



Black nickel, 14" & 15"
MT1415BN

1 HEADLINER® SERIES TIMBALES (PATENTED)

The MEINL Headliner® Series Timbales come in 13" and 14" sizes, are made from chrome plated steel, and come with a heavy-duty, height adjustable tilting stand. They provide the classic timbale sound and are the perfect introduction to the joy and passion of timbale playing at an affordable price.

SIZES 13" & 14"

MATERIAL Steel

FEATURE Logo applied from underneath the head (CN, US patent)

INCLUDES Height adjustable tilting double braced tripod stand
Tuning key
Wrench
Cowbell holder

FINISH Chrome

2 3 MARATHON® SERIES TIMBALES (PATENTED)

MEINL Marathon® Series Timbales are professionally equipped yet are offered at an affordable price. They are perfect for the working percussionist or to be included in a drum setup.

SIZES 14" & 15"

MATERIAL Steel

FEATURES Two worked in flanges
Heavy duty style brackets
Logo applied from underneath the head (CN, US patent)

INCLUDES Adjustable cowbell holder
Height adjustable tilting double braced tripod stand
Accessory pouch
L-shaped tuning key
Tune Up Oil

FINISHES
B = Brass
BN = Black nickel
CH = Chrome

1



BLACK POWDER COATING FOR DRY AND CUTTING SOUNDS

Black, 13" & 14"
TI1BK

2

FOR MORE INFO, SCAN THIS QR CODE OR CODE WITH YOUR SMARTPHONE



AMADITO VALDÈS, CUBA

Black, 14" & 15"
AV1BK

3



EXTRA DEEP SHELLS FOR SUPER PROJECTION AND GREAT BASS TONES

Black, 14" & 15"
MTT1415BK

FLOATUNE SERIES TIMBALES 1 2

- MATERIAL** Black powder coated steel
- FEATURES** Two worked in flanges
Floatune Tuning System
Logo applied from underneath the head (CN, US patent)
- INCLUDES** Adjustable cowbell holder
Height adjustable tilting double braced tripod stand
Accessory pouch
L-shaped tuning key
Tune Up Oil
- COLOUR** Black

1 FLOATUNE SERIES (PATENTED)

The MEINL Floatune Tuning System used on these timbales works without having to drill into the shell.

SIZES 13" & 14"

2 ARTIST SERIES TIMBALES (AMADITO VALDÈS) (PATENTED)

Our Artist Series Amadito Valdès Timbales – a tribute to one of the greatest timbaleros ever. Featuring our Floatune Tuning System and produce a dry and cutting sound due to the black powder coated shells.

SIZES 14" & 15"

3 MARATHON® SERIES TURBO TIMBALES (PATENTED)

The MEINL Turbo Timbales come with extra deep shells for super projection and great bass tones. Black

powder coating on the outside produces a dry, crisp and warm response.

SIZES 14" & 15"
10" deep

MATERIAL Black powder coated steel

FEATURES Three worked-in flanges
Heavy Duty style brackets
Logo applied from underneath the head (CN, US patent)

INCLUDES Adjustable cowbell holder
Height adjustable tilting double braced tripod stand
Accessory pouch
L-shaped tuning key
Tune Up oil

COLOUR BK = Black

ARTIST & PROFESSIONAL SERIES TIMBALES

1



LUIS CONTE, USA



Stainless steel, 14" & 15"
LC1STS



Solid brass, 14" & 15"
LC1BRASS

COUNTER SUNK BOLT HEAD AND BRACKET
CAST FROM SPECIAL ALLOY

TIMBALES

2



German B8 cymbal bronze, 14" & 15"
BT1415

THOUGHTFULLY ARRANGED LUGS ENABLE
AN EASY WAY TO PLAY THE CASCARA

FOR MORE INFO, SCAN THIS MEINL
QR CODE WITH YOUR SMARTPHONE



1 ARTIST SERIES TIMBALES (LUIS CONTE) (PATENTED)

It is with the greatest appreciation and the deepest respect that we honour our friend Luis and his life's work with his MEINL Artist Series Luis Conte Signature Timbales. Perfection in even the smallest details has been achieved in this outstanding instrument. All of the specifications Luis required for his instrument have been consequently realized.

SIZES 14" & 15"

MATERIALS **LC1BRASS:** Solid brass

LC1STS: Stainless steel

FEATURES Extensively hammered shells
Two worked in flanges
Cuban style flared out bottom edge

Brackets cast from special brass alloy
Logo applied from underneath the head
(CN, US patent)

INCLUDES Adjustable cowbell holder
Height adjustable tilting double braced tripod stand
Accessory pouch
L-shaped tuning key
Tune Up Oil

2 PROFESSIONAL SERIES TIMBALES (PATENTED)

The Roland Meinl Professional Series Timbales are made from finest German B8 cymbal bronze. They produce a fantastic warm sound with cutting rim shots and enhanced Cascara playing.

SIZES 14" & 15"

MATERIAL German B8 cymbal bronze

FEATURES Two worked in flanges
Cuban style flared out bottom edge
Brackets cast from special brass alloy
Logo applied from underneath the head
(CN, US patent)

INCLUDES Adjustable cowbell holder
Height adjustable tilting double braced tripod stand
Accessory pouch
L-shaped tuning key
Tune Up Oil

ADD PERC TO YOUR KIT

Tommy Clufetos (Ozzy Osbourne) uses MEINL Professional Congas and Attack Timbales in his setup.



DIRK VERBEUREN, BELGIUM



BENNY GREB, GERMANY



BRAM HAKKENS, NETHERLANDS



TOMMY CLUFETOS, USA



JULIO FIGUEROA, USA



JOHNNY RABB, USA



GREG BISHOP, UK



1 NEW!



SNARE WIRES ARE ABSOLUTELY QUIET AND CHATTER-FREE IN THE "OFF" POSITION

2



Chrome, 8" & 10"
MIT810CH



Chrome, 13"
MDT13CH



Black, 10"
MDST10BK

Black, 8"
MDST8BK



CHAD WACKERMAN, USA

1 DRUMMER SNARE TIMBALES (PATENTED)

The Drummer Snare Timbales feature a crisp snare effect. The super-positive snare throw-off is fast and simple. We designed a special bracket to hold the snare wires absolutely quiet and chatter-free in the "off" position.

SIZES 8", 10"

MATERIAL Steel

FEATURES Strong mounting clamp
Quick snare on/off system
Chatter-free "off" position
Logo applied from underneath the head (CN, US patent)

COLOUR BK = Black

2 DRUMMER TIMBALE MINI TIMBALES (PATENTED)

The MEINL Drummer and Mini Timbales provide the characteristic timbale sounds and projection that cuts through any band setting. It is a perfect addition to any percussion or drum set configuration.

SIZES **MDT13CH:** 13" drummer timbale
MIT810CH: 8" & 10" mini timbale

MATERIAL Steel

FEATURES Strong mounting clamp
Logo applied from underneath the head (CN, US patent)

INCLUDES L-shaped tuning key
Tune Up Oil

FINISH Chrome



TAKU HIRANO, USA

3

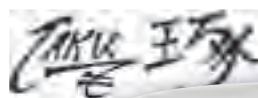

SPECIAL DESIGNED RIM

Black, 13"
MHT13BK



4



STRONG MOUNTING CLAMPS



DAVE MACKINTOSH, UK

Black nickel, 8"x9", 8"x11"
MDT88BN

**3 ARTIST SERIES SIGNATURE
HAND-BALE (TAKU HIRANO)
(DGBM/GERMAN REGISTERED UTILITY MODEL)
(PATENTED)**

No sticks? No problem!
The retaining rim of the Hand-Bale is uniquely made with one half traditionally shaped, while the other half of the rim is recessed below the shell.

- SIZE** 13"
- MATERIAL** Steel
- FEATURES** Special designed rim
Strong mounting clamp
Logo applied from underneath the head (CN, US patent)
- INCLUDES** L-shaped tuning key
Tune Up Oil
- COLOUR** BK = Black, high gloss

**4 ARTIST SERIES SIGNATURE
ATTACK TIMBALES (DAVE MACKINTOSH)
(PATENTED)**

We made a pair of 8" diameter timbale shells with a depth of 9" and 11" respectively. This creates a distinctive and tightly matched interval "dialogue". The Dave Mackintosh's Signature Attack Timbales are easily mounted on a rack, drum set, or any standard L-rod.

- SIZES** 8" x 9", 8" x 11"
- MATERIAL** Steel
- FEATURES** Strong mounting clamps
Logo applied from underneath the head (CN, US patent)
- INCLUDES** L-shaped tuning key
Tune Up Oil
- COLOUR** BN = Black Nickel

SAMBA



01 Sheets of Poplar Wood for our timbas.

02 A wooden surdo in formation.

03 Initial forming of a surdo body.

04 Surdo body heli-arc welded.

05 The surdos legs have to be parallel.

06 Setting up the surdo with its tuning rods.

07 Tamborim head in the press.

08 The head is fitted to the tamborim.

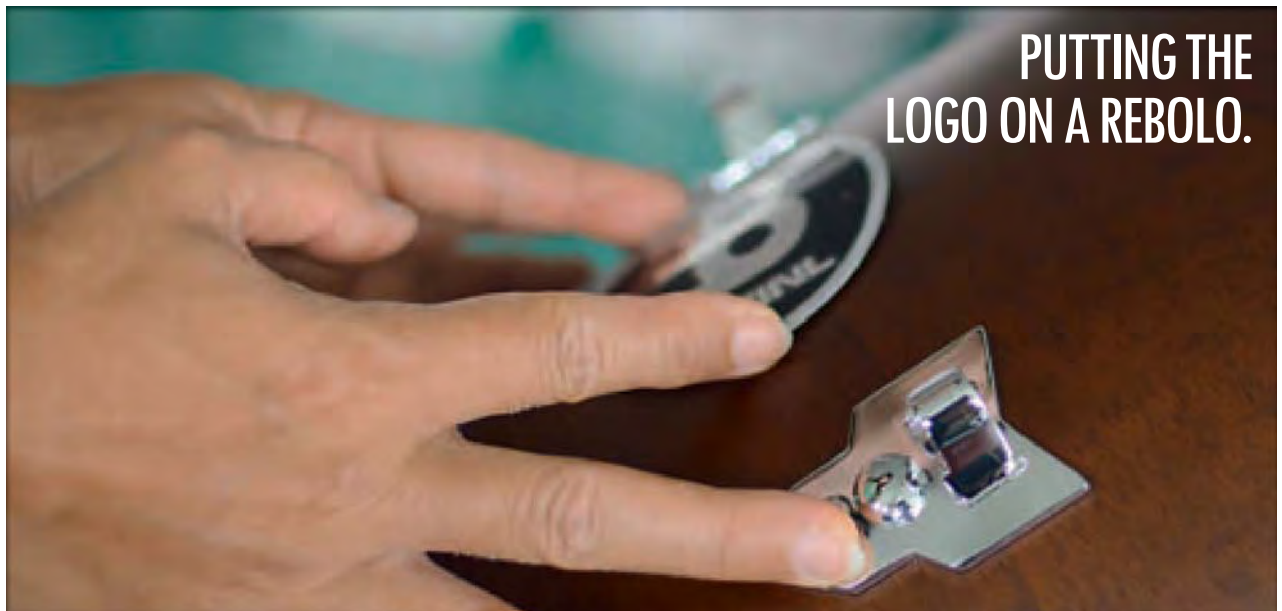
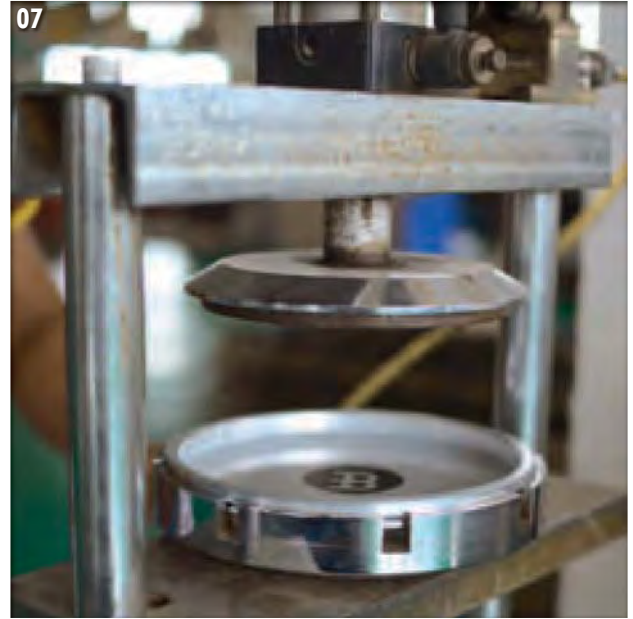

1



22"
SU22

20"
SU20

18"
SU18

16"
SU16

LIGHT WEIGHT ALUMINUM

2



22"
SU22AB-M

20"
SU20AB-M

18"
SU18AB-M

16"
SU16AB-M

ALL MEINL SURDOS COME WITH NAPA HEAD ON TOP FOR ANOTHER HEAD OPTION

1 TRADITIONAL ALUMINUM SURDOS (PATENTED)

The deep sound of the Surdo is the heartbeat of Samba music. MEINL offers several sizes made from premium aluminum.

SIZES 16" x 20", 18" x 22",
20" x 24", 22" x 24"

MATERIAL Aluminum

FEATURES Countersunk bolt heads

Chrome plated hardware

Two head options

8 tuning lugs (16" & 18" models)

10 tuning lugs (20" & 22" models)

Logo applied from underneath the head (CN, US patent)

INCLUDES Tuning key

2 TRADITIONAL WOOD SURDOS (PATENTED)

The MEINL Wood Surdos have all the great features of our Aluminium Surdos, but with wooden shells for a warmer sound. They deliver the full bass notes that are the heartbeat of Samba music.

SIZES 16" x 20", 18" x 22", 20" x 24", 22" x 24"

MATERIAL Six-ply hardwood shells

FEATURES Countersunk bolt heads

Chrome plated hardware

Two head options

8 tuning lugs (16" & 18" models)

10 tuning lugs (20" & 22" models)

Logo applied from underneath the head (CN, US patent)

INCLUDES Tuning key

COLOUR AB = African Brown

FINISH Matte



SAMBA STAND ALONE SURDOS

SAMBA

1



22"
SU22-L

20"
SU20-L

18"
SU18-L

16"
SU16-L

2



22"
SU22-L-AB-M

20"
SU20-L-AB-M

18"
SU18-L-AB-M

16"
SU16-L-AB-M

SIX-PLY HARDWOOD SHELLS FOR A FULL AND WARM SOUND

1 TRADITIONAL STAND ALONE ALUMINUM SURDOS (PATENTED)

MEINL percussion offers stand alone Surdos made out of aluminum that are equipped with sturdy, height adjustable legs placed on the floor while playing.

SIZES 16" x 20", 18" x 22",
20" x 24", 22" x 24"

MATERIAL Aluminum

FEATURES Height adjustable legs
Countersunk bolt heads
Chrome plated hardware
Two head options
8 tuning lugs (16" & 18" models)
10 tuning lugs (20" & 22" models)
Logo applied from underneath the head (CN, US patent)

INCLUDES Tuning key

2 TRADITIONAL STAND ALONE WOOD SURDOS (PATENTED)

The MEINL Stand Alone Wood Surdos have all the great features of our aluminum surdos, but with wooden shells for a warmer sound. They deliver the full bass notes that are the heartbeat of Samba music. These surdos are perfect for stationary playing, on stage, or in a drum circle!

SIZES 16" x 20", 18" x 22",
20" x 24", 22" x 24"

MATERIAL Six-ply hardwood shells

FEATURES Height adjustable legs
Countersunk bolt heads
Chrome plated hardware
Two head options
8 tuning lugs (16" & 18" models)
10 tuning lugs (20" & 22" models)
Logo applied from underneath the head (CN, US patent)

INCLUDES Tuning key
COLOUR AB = African Brown
FINISH Matte



**WOUTER DE GOOYERT,
NETHERLANDS**



CHARLY BÖCK, GERMANY



MARCO CATINACCIO, ITALY



TOMBACK, ECUADOR



THE ORIGINAL DANCE MUSIC

1



SHORTER SHELLS ENABLE TO WEAR
IN MUCH LOWER POSITION

22"
SUB22

20"
SUB20

18"
SUB18

2



22"
SUB22AB-M

20"
SUB20AB-M

18"
SUB18AB-M

1 BAHIA ALUMINUM SURDOS (PATENTED)

Bahia Surdos are made to celebrate Samba-Reggae. Each surdo is cut shorter than its Rio counterpart and typically worn much lower, on a belt. Our three sizes offer two great sounding fundos and a higher third-surdo.

SIZES 18" x 16", 20" x 16",
22" x 18"

MATERIAL Aluminum

FEATURES Countersunk bolt heads
Chrome plated hardware
Two head options
8 tuning lugs (18" model)
10 tuning lugs (20" & 22" models)
Logo applied from underneath the head
(CN, US patent)

INCLUDES Tuning key

2 BAHIA WOOD SURDOS (PATENTED)

Our wooden Bahia Surdos celebrate Samba-Reggae music with warm-sounding shells. The three sizes offer the classic high-low fundos and a higher pitched third surdo. Each surdo is cut shorter than its Rio counterpart, and typically worn much lower, on a belt.

SIZES 18" x 16", 20" x 16",
22" x 18"

MATERIAL Six-ply hardwood shells

FEATURES Countersunk bolt heads
Chrome plated hardware
Two head options
8 tuning lugs (18" model)
10 tuning lugs (20" & 22" models)
Logo applied from underneath the head
(CN, US patent)

INCLUDES Tuning key

COLOUR AB = African Brown
FINISH Matte

SAMBA CAIXAS & REPINIQUES

1



14" x 4"
CA14



12" x 4 1/2"
CA12

PROFESSIONAL SNARE
THROW-OFF MECHANISM



GILSON SILVEIRA, ITALY

2



12" x 6"
CA12T

TRADITIONAL STYLE WITH
GUITAR STRINGS

3



COUNTERSUNK BOLT HEAD

12" x 12"
RE12

10" x 10"
RE10

4



12" x 12"
RE12AB-M

CAIXAS 1 2

With shells made from premium aluminum, these caixas produce the classic bright and cutting sound with penetrating rim shots that these instruments are supposed to deliver.

MATERIAL Aluminum

INCLUDES Tuning key

1 ALUMINUM CAIXAS (PATENTED)

SIZES 12" x 4 1/2"
14" x 4"

FEATURES Replaceable synthetic heads
Countersunk bolt heads
Steel snare wires
Logo applied from underneath the head (CN, US patent)
Professional snare throw-off mechanism

2 TRADITIONAL ALUMINUM CAIXA (PATENTED)

SIZE 12" x 6"

FEATURES Traditional style snares made from guitar strings
Extra deep body
Countersunk bolt heads
Logo applied from underneath the head (CN, US patent)
Replaceable synthetic heads

REPINIQUES 3 4

The Repinique is played with a stick while the other hand is used for open tones and slaps. MEINL offers aluminum and wooden versions.

FEATURES Countersunk bolt heads
Chrome plated hardware
Replaceable synthetic heads

6 tuning lugs (10" model)
8 tuning lugs (12" model)
Logo applied from underneath the head (CN, US patent)
INCLUDES Tuning key

3 ALUMINUM REPINIQUES (PATENTED)

SIZES 10" x 10"
12" x 12"

MATERIAL Aluminum

4 WOOD REPINIQUE (PATENTED)

SIZE 12" x 12"
MATERIAL Rubber Wood
(*Hevea brasiliensis* Muell.-Arg.)
COLOUR AB = African Brown
FINISH Matte

1



14" x 35"
TIM1435AB-M



14" x 28"
TIM1428AB-M



STRONG HOOK TO CARRY IT ON A BELT

2



12" x 18"
REB1218AB-M

3



14" x 28"
TAN1428AB-M



NAPA HEAD FOR REDUCED OVERTONES



ROLAND PEIL, GERMANY

1 TIMBAS (PATENTED)

The MEINL Timba has a light weight shell, a thin synthetic head, and mechanical lug tuning. The tones are sharp, clear, and bright.

SIZES 14" x 28", 14" x 35"

MATERIAL Poplar Wood (*Populus*)

FEATURES Light weight shell

Replaceable synthetic head

Chrome plated hardware

Comfortable rounded rim

Logo applied from underneath the head (CN, US patent)

Strong hook to carry it on a belt

INCLUDES Tuning key

COLOUR AB = African Brown

FINISH Matte

2 REBOLO

The Rebolo is a Brazilian ensemble drum with warm, deep tones. It comes with a Napa head and is usually played in the seated position.

SIZE 12" x 18"

MATERIAL Poplar Wood (*Populus*)

FEATURES Lightweight shell

Replaceable synthetic Napa head

Chrome plated hardware

Mechanical lug tuning

Strong hooks to carry it on a belt

Tuning Key

INCLUDES Tuning Key

COLOUR AB = African Brown

FINISH Matte

3 TANTAM

The Tantam is a drum with warm, deep tones, usually played in Pagode, a specific genre of samba. One hand plays on the head, while the other hand plays a sharper counterpoint tone on the shell.

SIZE 14" x 28"

MATERIAL Poplar Wood (*Populus*)

FEATURES Lightweight shell

Replaceable synthetic Napa head

Chrome plated hardware

Mechanical lug tuning

Strong hooks to carry it on a belt

INCLUDES Tuning key

COLOUR AB = African Brown

FINISH Matte

SAMBA CUICAS & WHISTLE & ROCARS & TRIANGLE



10" QW10

6" QW6



8" QW7R



SW1



RC1BK

20 PAIRS OF SOLID JINGLES



RC2-L



15 3/4" STR140



RC2-M

THREE TONES

1 ALUMINUM CUICAS

MEINL offers two cuicas made from lightweight aluminum. Their light weight and solid construction makes them perfect for street Samba.

SIZES 6", 10"

MATERIAL Aluminum

FEATURES Countersunk bolt heads (QW10)

Hand selected goat heads

INCLUDES Tuning key

FEATURES Floatune Tuning System
Hand selected goat head

INCLUDES Tuning key

3 SAMBA WHISTLE

This samba whistle has three tones in a super-bright timbre.

MATERIAL Aluminum

INCLUDES Neck lanyard

2 FIBERGLASS CUICA

While one hand rubs the internal bamboo shaft with a moist cloth, the other hand controls the pressure of the head, thereby changing the pitch.

SIZE 8"

MATERIAL Premium fiberglass

COLOUR R = Red

4 MODERN STYLE ROCAR

The MEINL Rocar is equipped with 20 pairs of solid jingles mounted onto a wooden bar.

MATERIAL Rubber Wood
(*Hevea brasiliensis* Muell.-Arg.)

FEATURE 20 pairs of solid jingles

COLOUR BK = Black

5 SAMBA TRIANGLE

The Samba Triangle is made extra large for a bold sound that can be heard over a Samba ensemble.

SIZE 15 3/4"

MATERIAL Steel

FEATURE Thick steel for extra volume

INCLUDES Extra large Triangle Beater

6 ALUMINUM ROCARS

The MEINL Aluminum Rocars come in lightweight frames that hold an array of cupped aluminum jingles.

SIZES Medium

Large

MATERIAL Aluminum frame and jingles

FEATURES Light weight frame

Loud projection



**Small
STBAG1**

**Large
STBAG2**

**Small
STBAG4-CH**

**Large
STBAG2-CH**

**Medium
STBAG3-CH**

**Medium
STBAGTRI-CH**

TONALLY MATCHED

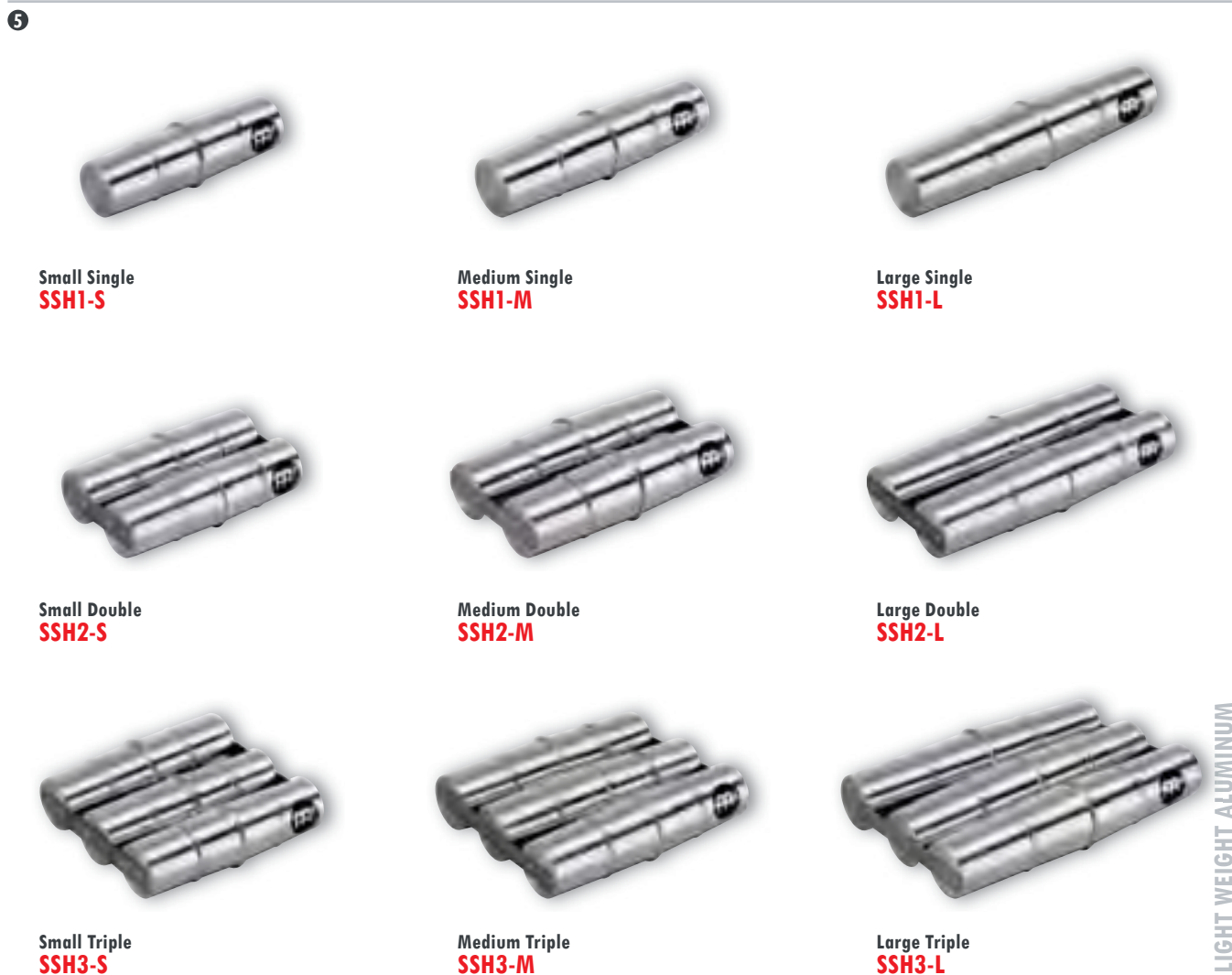

**Small Single
SSH1-S**

**Medium Single
SSH1-M**

**Large Single
SSH1-L**

**Small Double
SSH2-S**

**Medium Double
SSH2-M**

**Large Double
SSH2-L**

**Small Triple
SSH3-S**

**Medium Triple
SSH3-M**

**Large Triple
SSH3-L**

LIGHT WEIGHT ALUMINUM

1 MODERN STYLE A-GO-GO STEEL FINISH MODELS

The MEINL A-Go-Go Bells are tonally matched especially for the requirements of South American rhythms.

- SIZES** Small, Large
- MATERIAL** Special steel alloy
- INCLUDES** Mounting clamp for small model
- FINISH** Hand brushed steel

2 MODERN STYLE A-GO-GO CHROME FINISH MODELS

These highly polished A-Go-Go Bells offer a bright sound and are equipped with a flexible connection. Ideal for Samba style music.

- SIZES** Small, Large
- MATERIAL** Special steel alloy
- FEATURE** Flexible connection
- FINISH** High polished chrome

3 TRADITIONAL STYLE A-GO-GO BELL

The MEINL traditional style A-Go-Go Bell in our medium size is the perfect A-Go-Go Bell when the large is too much and the small one isn't enough.

- SIZE** Medium
- MATERIAL** Special steel alloy
- FEATURES** Traditional shape
Flexible connection
- FINISH** High polished chrome

4 TRIPLE A-GO-GO BELL

The Triple A Go-Go Bell has three tonally matched bells for a sweet sound fitting any musical style. The high bell may be played in counterpoint off the middle bell by compressing the spring handle. Bright chrome finish will hold up under intense play.

- SIZE** Medium
- MATERIAL** Chrome plated steel
- FEATURES** Traditional Shape
Tonally matched bells in equal intervals
Spring handle enables counterpoint rhythms
- FINISH** Chrome

5 ALUMINUM SAMBA SHAKERS

This are the ideal instruments for street Samba. Their shells are made from thin aluminum, which, when combined with solid steel shot, produce a warm, penetrating, and cutting shaker sound.

- SIZES** Small, Medium, Large
- MATERIAL** Aluminum

SAMBA TAMPEIRO & TAMBORIMS

1

INVENTOR:
JOSÉ J. CORTIJO

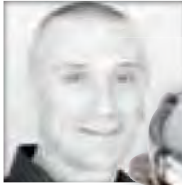

THREE PAIRS OF
STEEL JINGLES

Rubber Wood, African Brown
TPO6AB-M

2

NEW!



STBR06ABS-BK

MESH HEAD FOR SUPER
LOW VOLUME PRACTICE

3



ABS, Black
TBR06ABS-BK



ABS, Green
TBR06ABS-GR



Chrome
TBR06CH



Brass
TBR06B



ABS, Yellow
TBR06ABS-Y



Rubber Wood, Super Natural
TBR06SNT-M



Aluminum
TBR06ALU



ABS, Red
TBR06ABS-R

WE OFFER A VARIETY OF TAMBORIMS FROM SEVERAL
MATERIALS FOR DIFFERENT SOUND OPTIONS

1 TAMPEIRO (PATENTED)

Three pairs of steel jingles on a wooden tampeiro frame create an exciting new sound. A traditional sharp cutting tampeiro with a bright metallic accent! It may also be played with pandeiro techniques, for lighter accompaniment.

SIZE 6"

MATERIAL Rubber Wood
(*Hevea brasiliensis* Muell.-Arg.)

FEATURES Floatune Tuning System
Logo applied from underneath the head (CN, US patent)
Countersunk bolt lugs
Replaceable synthetic head
Three pairs of steel jingles

INCLUDES Thai coin as tuning key

COLOUR AB = African Brown

2 SILENT TAMBORIM

The MEINL Silent Tamborim is meant for the serious player who wants to perfect their tamborim technique. Hours of quiet play are possible without sonic overload. The Silent Tamborim has the same weight and balance as a regular model but with a super-strong mesh head. The head reacts the same way as our synthetic Tamborim head, just at whisper volume.

SIZE 6" diameter

MATERIALS ABS plastic
Mesh head

FEATURE Mesh head for super low volume practice

COLOUR BK = Black

3 FLOATUNE TAMBORIMS (PATENTED)

Tamborims are played with a plastic stick while one hand changes the pitch of the drum. It has a bright,

loud, and cutting sound. MEINL offers a variety of tamborims all made from several high quality materials for different sound options.

SIZE 6"

MATERIALS ABS
Aluminum
Brass plated steel
Chrome plated steel
Rubber Wood
(*Hevea brasiliensis* Muell.-Arg.)

FEATURES Floatune Tuning System
Logo applied from underneath the head (CN, US patent)
Countersunk bolt lugs
Replaceable synthetic heads

INCLUDES Thai coin as tuning key

FRAME DRUMS



01 After bending the frame, it gets glued and cut into the proper shell depth.

02 The thumb hole of our deep shell frame drums has to be comfortable. Even after the finish is dry we check again.

03 All skins are carefully inspected for faultless quality.

04 A frame is being set with glue, just before the skin goes on.

05 The head is secured to the frame with glue and a band.

06 The extra skin is being removed. The frame drum is sitting inside a cutting guide jig ensuring a perfect cut.

07 The head is tacked securely to the frame.

08 Mounting a True Feel head on a deep shell frame drum.



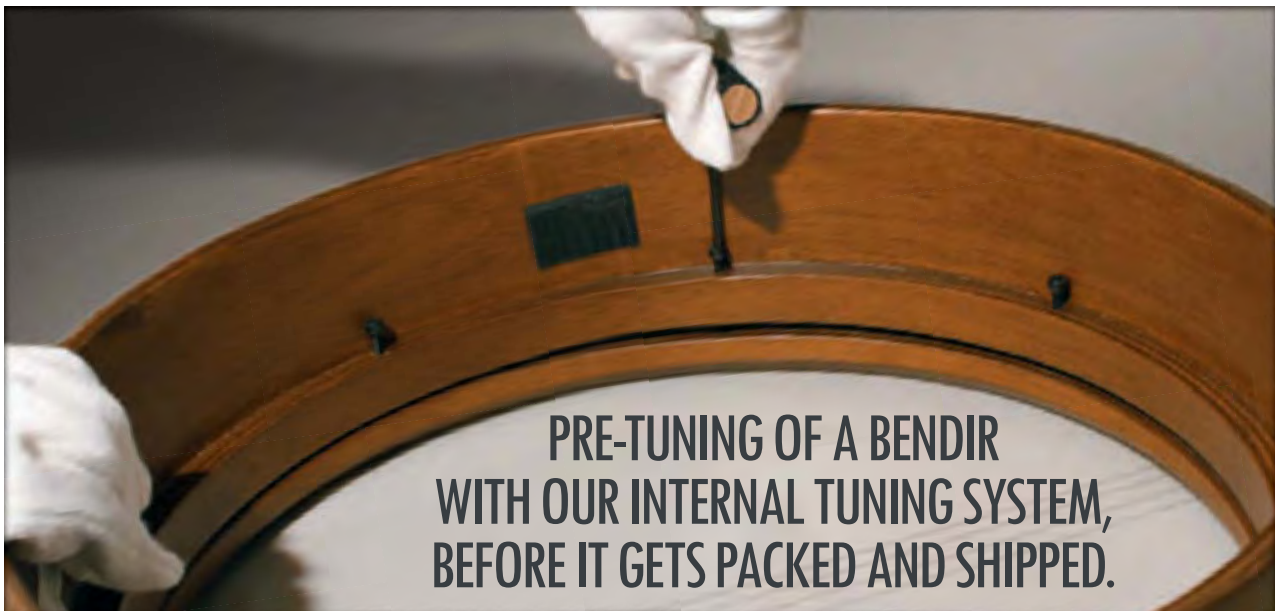

1



22" x 2 1/2"
FD22T



20" x 2 1/2"
FD20T

18" x 2 1/2"
FD18T

16" x 2 1/2"
FD16T

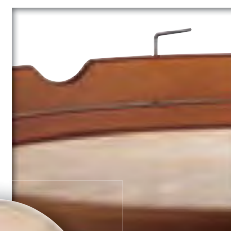

INTERNAL LUG TUNING SYSTEM

2



22" x 2 1/2"
FD22T-TF

TRUE FEEL SYNTHETIC HEADS PREVENT THE DRUM'S PITCH FROM BEING AFFECTED BY HUMIDITY IN OUTDOOR VENUES



20" x 2 1/2"
FD20T-TF

18" x 2 1/2"
FD18T-TF

16" x 2 1/2"
FD16T-TF

FOR MORE INFO, SCAN THIS MEINL QR CODE WITH YOUR SMARTPHONE



TARS 1 2

MEINL Tars are tunable frame drums, available with hand selected goatskin or True Feel synthetic heads. The tuning lugs are fully recessed within the frame for minimal interference. A scalloped thumb notch and light weight ensure comfortable playing.

SIZES 16", 18", 20", 22"
2 1/2" deep

FEATURE Internal lug tuning system

INCLUDES Allen wrench

COLOUR AB = African Brown

FINISH Matte

1 GOAT SKIN TARS

MATERIALS Rubber Wood
(*Hevea brasiliensis* Muell.-Arg.)
Hand selected goat head

2 SYNTHETIC HEAD TARS

MATERIALS Rubber Wood
(*Hevea brasiliensis* Muell.-Arg.)
True Feel synthetic head



LARRY SALZMAN, USA

FRAME DRUMS MIZHARS

1



18" x 4"
FD18T-D

DEEP SHELL CONSTRUCTION FOR FULL SOUND DEVELOPMENT



14" x 4"
FD14T-D

12" x 4"
FD12T-D

FOR MORE INFO, SCAN THIS QR CODE
OR CODE WITH YOUR SMARTPHONE



FRAME DRUMS

2



18" x 4"
FD18T-D-TF

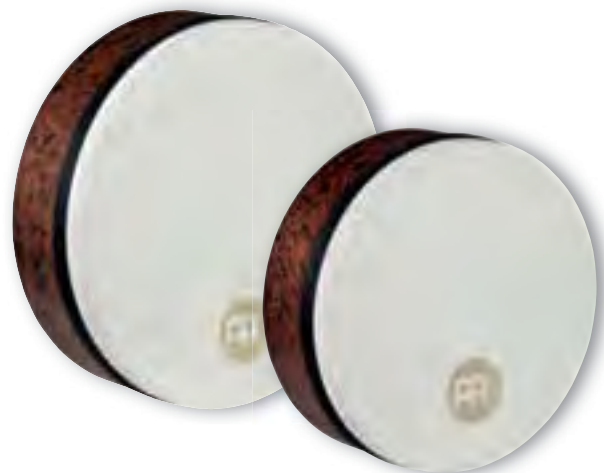

14" x 4"
FD14T-D-TF

12" x 4"
FD12T-D-TF

MIZHARS 1 2

Mizhars have an internal tuning system, and a traditional thumb hole grip for comfortable playing in the traditional style. The deep shell offers excellent sound development and comes in a stunning burl finish. Those drums are available with a hand selected goat head or with a True Feel synthetic head.

SIZES 12", 14", 18"
4" deep

FEATURES Thumb hole grip
Deep shell construction for full sound development
Internal tuning system
Stunning burl finish

INCLUDES Allen wrench
COLOUR BB = Brown Burl
FINISH Matte

1 GOAT SKIN MIZHARS

MATERIALS Rubber Wood
(*Hevea brasiliensis* Muell.-Arg.)
Hand selected goat head

2 SYNTHETIC HEAD MIZHARS

MATERIALS Rubber Wood
(*Hevea brasiliensis* Muell.-Arg.)
True Feel synthetic head



THUMB HOLE FOR A GOOD BALANCE
AND COMFORTABLE PLAYING

1



16" x 2 1/2"
FD16BE



14" x 4"
FD14BE

12" x 4"
FD12BE

2



16" x 2 1/2"
FD16BE-TF



14" x 4"
FD14BE-TF

12" x 4"
FD12BE-TF

BENDIRS 1 2

Bendirs feature four thin strings stretched across the inside of the head, which create the classic Bendir "buzzing" sound. Those drums are fully tunable and light in weight for long and comfortable playing. MEINL offers goatskin as well as synthetic True Feel head versions. This fine frame drums are fully tunable, with rich bass tones and crisp taks. The frame is made for comfort and extended play.

SIZES 12" x 4"
14" x 4"
16" x 2 1/2"

FEATURES Internal tuning system
Buzzing effect
Thumb hole for a good balance and comfortable playing (only for 4" deep frames)

INCLUDES Allen wrench
COLOUR AB = African Brown
FINISH Matte

1 GOAT SKIN BENDIRS

MATERIALS Rubber Wood
(*Hevea brasiliensis* Muell.-Arg.)
Hand selected goat head

2 SYNTHETIC HEAD BENDIRS

MATERIALS Rubber Wood
(*Hevea brasiliensis* Muell.-Arg.)
True Feel synthetic head

BODHRANS 3 4

Bodhrans are known for their earthy and warm tones. MEINL offers two different versions, a Celtic model featuring a cross bar and an Irish model that comes with an extra deep frame and a dampening layer on the head.

3 CELTIC BODHRAN

SIZE 18" x 4"
MATERIALS Rubber Wood
(*Hevea brasiliensis* Muell.-Arg.)
Hand selected goat head

FEATURES Cross bar
Internal tuning system

INCLUDES Allen wrench
COLOUR AB = African Brown
FINISH Matte

FRAME DRUMS BODHRANS & DAFS & KANJIRA

3



18" x 4"
FD18BO



CROSS BAR

4



14" x 6"
FD14IBO

DAMPENING LAYER FOR LESS OVERTONES

5



20" x 2 1/2"
FD20D-TF

20" x 2 1/2"
FD20D-WH

METAL RINGS FOR SPECIAL EFFECTS

6



7 1/2" x 2 1/4"
FD7KA



RÜDIGER MAUL, GERMANY

4 IRISH BODHRAN

The Irish Bodhran features an extra-deep shell for a rich, full sound, and an extra dampening layer on the rim to reduce overtones. The traditional cross brace has been removed to enable direct hand pressure on the head for contemporary pitch-bending techniques.

SIZE 14" x 6"

MATERIALS Rubber Wood
(*Hevea brasiliensis* Muell.-Arg.)
Hand selected goat head

FEATURES Extra deep shell for full sound development
Dampening layer around rim for reduced overtones

INCLUDES Allen wrench

COLOUR BB = Brown Burl

FINISH Matte

5 DAFS

The Daf is a classical Persian frame drum with a rich tradition. It has ring snares nearly all the way around the inside of the shell, and is played with a lot of movement. The MEINL Daf comes either with the a True Feel synthetic head or with a woven texture synthetic head.

SIZE 20" x 2 1/2"

MATERIALS Rubber Wood
(*Hevea brasiliensis* Muell.-Arg.)

FD20D-TF: True Feel synthetic head

FD20D-WH: Woven synthetic head

FEATURES Metal rings for special effects
Pre-tuned construction for extra light weight

COLOUR AB = African Brown

FINISH Matte

6 KANJIRA

The Kanjira is a traditional frame drum from southern India that is played with bending-pitch and split hand techniques. Amazing sounds and complex rhythms are possible from this rich little drum.

SIZE 7 1/2" x 2 1/4"

MATERIALS Rubber Wood
(*Hevea brasiliensis* Muell.-Arg.)
Hand selected goat head

FEATURES Many sound options
Set of 3 jingles

INCLUDES Allen wrench

COLOUR AB = African Brown

FINISH Matte



SEALABLE FILLING PORT ALLOWS YOU TO CONTROL THE AMOUNT OF STEEL BALLS INSIDE

20" x 2 3/4"
FD20SD

18" x 2 3/4"
FD18SD-TF

16" x 2 3/4"
FD16SD



8", 10", 12"
PL-SET



15"
HOD15

12 1/2"
HOD125

NEW!



NEW!

16"
HD16AB

14"
HD14AB

12"
HD12AB

10"
HD10AB

16"
HD16AB-TF

14"
HD14AB-TF

12"
HD12AB-TF

10"
HD10AB-TF

1 SEA DRUMS

MEINL Sea Drums create the soothing sounds of the surf, with a great new feature: A sealable filling port allows you to control the amount of steel balls inside.

SIZES 16", 18", 20"
2 3/4" deep

MATERIALS Rubber Wood

(*Hevea brasiliensis* Muell.-Arg.)

Hand selected goat head and synthetic head
FD18SD-TF: True Feel synthetic head and transparent head

FEATURE Sealable filling port allows you to control the amount of steel balls inside

COLOUR AB = African Brown

FINISH Matte

2 PLENERA SET

The Plenera is a traditional frame drum from Puerto Rico. The frames are made from rugged plastic and external mechanical lugs tune the hand-selected goatskin heads.

SIZES Quinto = 8"
Seguidor = 10"
Tumbador = 12"

MATERIALS ABS Plastic frames
Goatskin heads

FEATURE External mechanical lug tuning

INCLUDES Nylon Bag

Tuning Keys

3 NATIVE AMERICAN-STYLE HOOP DRUM

These frame drums have a hand selected buffalo head for an authentic sound that is both warm and powerful.

SIZES 12 1/2", 15"

MATERIALS Hand selected buffalo head
Nylon lacing and grip

FEATURES Warm and powerful sound
Adjustable hand grip

INCLUDES Leather padded wooden beater

4 HAND DRUMS

Hand Drums are equipped with either the finest hand selected goat heads or with our synthetic True Feel heads. The scalloped frame guarantees a comfortable grip.

SIZES 10", 12", 14", 16"

MATERIALS Rubber Wood (*Hevea brasiliensis* Muell.-Arg.)
Hand selected goat heads

TF: True Feel synthetic head

COLOUR AB = African Brown

FRAME DRUMS PANDEIROS

1



Napa head, 10"
PA10ABS-BK-NH

NAPA HEAD FOR
REDUCED OVERTONES



Clear Mylar head, 10"
PA10ABS-BK



FOR MORE INFO, SCAN THIS MEINL
QR CODE WITH YOUR SMARTPHONE

2



Goat head, 12"
PA12CN-M



Goat head, 10"
PA10CN-M



SOLID JINGLES

3



Goat head, 12"
PA12AB-M



Goat head, 10"
PA10AB-M



HAND-HAMMERED
BRASS JINGLES

4



True Feel synthetic head, 12"
PAV12AB-M-TF



True Feel synthetic head, 10"
PAV10AB-M-TF



PERFORATED HAND-
HAMMERED BRASS JINGLES

PANDEIROS

The Pandeiro is played with one hand while the other alters the pitch of the drum. MEINL Pandeiros are available with different jingle and head variations.

1 TRADITIONAL ABS PANDEIROS

SIZE 10"

MATERIALS ABS plastic

PA10ABS-BK: Replaceable synthetic head

PA10ABS-BK-NH: Replaceable Napa head

FEATURES Countersunk bolt lugs

Chrome plated jingles and hardware

PA10ABS-BK: Logo applied from under-

neath the head (CN, US patent)

PA10ABS-BK-NH: Reduced overtones

INCLUDES Tuning key

COLOUR BK = Black

2 TRADITIONAL WOOD PANDEIROS

SIZES 10", 12"

MATERIALS Rubber Wood

(*Hevea brasiliensis* Muell.-Arg.)

Replaceable hand selected goat heads

FEATURES Countersunk bolt lugs

Chrome plated jingles and hardware

INCLUDES Tuning key

COLOUR CN-M = Chest Nut, matte

3 SHELL-TUNED GOAT SKIN PANDEIROS

SIZES 10", 12"

MATERIALS Rubber Wood

(*Hevea brasiliensis* Muell.-Arg.)

Hand selected goat head

FEATURES Hand-hammered brass jingles

Internal lug tuning system

Light weight

INCLUDES Allen wrench

COLOUR AB-M = African Brown, matte

4 SHELL-TUNED SYNTHETIC HEAD PANDEIROS

SIZES 10", 12"

MATERIALS Rubber Wood

(*Hevea brasiliensis* Muell.-Arg.)

True Feel synthetic head

FEATURES Perforated hand-hammered brass jingles

for extra dry sound

Internal lug tuning system

Light weight

INCLUDES Allen wrench

COLOUR AB-M = African Brown, matte

TAMBOURINES

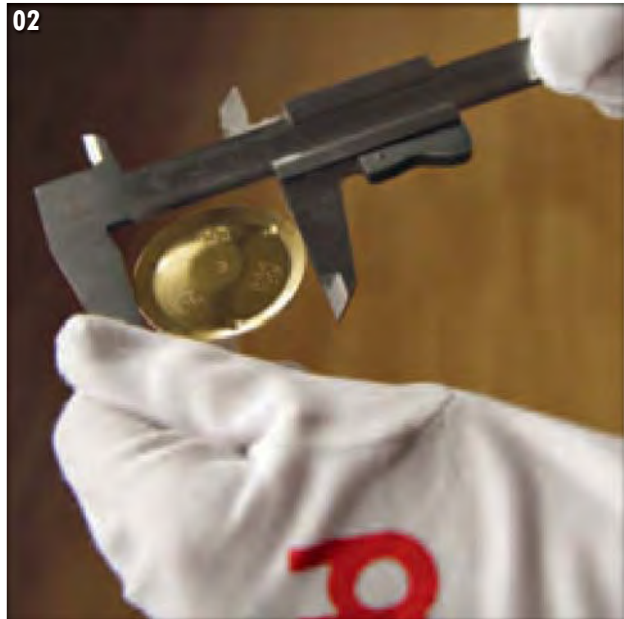

01 Forming the jingles.

02 Our jingles are precision made.

03 A brass super dry jingle is cut from the stock sheet.

04 The jingles are polished in a special bath with metal beads.

05 Every jingle has to be carefully checked before it can be mounted on a frame.

06 The jingle slots of this 2 row tambourine are being sanded.

07 The tambourines are assembled by hand.

08 The jingles are nail-set into the frame.

09 The nails are also secured with glue.

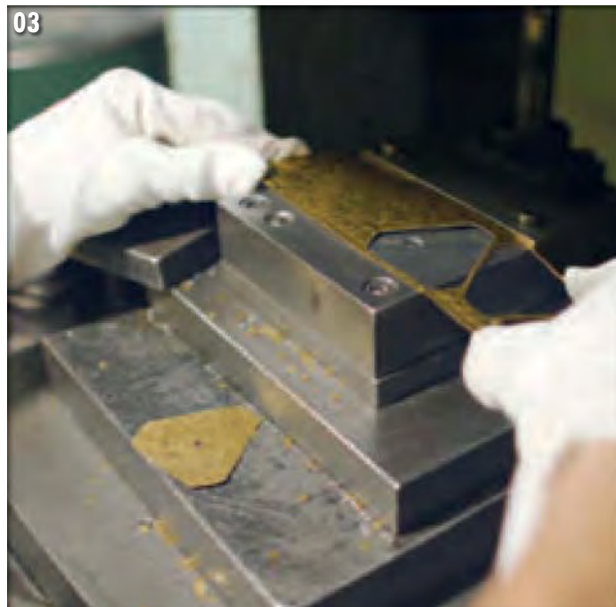



LOGO APPLIED WITH HOT
IRON BRAND ON OUR
ARTISAN EDITION
TAMBOURINES.

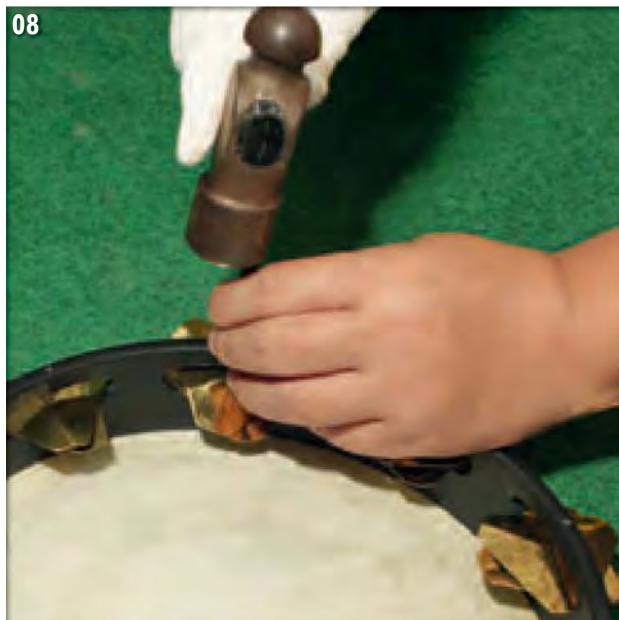

1



1 row
TAH1AB



2 rows
TAH2AB



NICKEL SILVER
PLATED STEEL

2



1 row
TAH1A-AB



2 rows
TAH2A-AB



ALUMINUM

3



1 row
TAH1M-SNT



2 rows
TAH2M-SNT



STEEL / SOLID BRASS

4



1 row
TAH1B-AB



2 rows
TAH2B-AB



SOLID BRASS

HEADED WOOD TAMBOURINES

MEINL's Heated Wood Tambourines are made from a sturdy frame with jingles available in different materials, resulting in various sound possibilities. Each head is hand selected to provide best quality on these pre-tuned drums.

1 REGULAR GOAT-SKIN WOOD TAMBOURINES, STEEL JINGLES

SIZE 10"

MATERIALS Nickelsilver plated steel
Hand selected goat heads
Wooden frame

FEATURE 1 row and 2 row version

COLOUR AB = African Brown

2 REGULAR GOAT-SKIN WOOD TAMBOURINES, ALUMINUM JINGLES

SIZE 10"

MATERIALS Aluminum
Hand selected goat heads
Wooden frame

FEATURE 1 row and 2 row version

COLOUR AB = African Brown

3 RECORDING-COMBO GOAT-SKIN WOOD TAMBOURINES, DUAL-ALLOY JINGLES

SIZE 10"

MATERIALS Steel / Solid brass
Hand selected goat heads
Wooden frame

FEATURES Dual-alloy jingles
1 row and 2 row version

COLOUR SNT = Super Natural

4 REGULAR GOAT-SKIN WOOD TAMBOURINES, BRASS JINGLES

SIZE 10"

MATERIALS Solid brass
Hand selected goat heads
Wooden frame

FEATURE 1 row and 2 row version

COLOUR AB = African Brown

KONRAD GRAF, GERMANY



5



1 row
TAH1BK-R-TF



2 rows
TAH2BK-R-TF

TRUE FEEL SYNTHETIC HEADS ARE
CONSISTENT UNDER VARIABLE CONDITIONS

6



1 row
STAH1S-BK



2 rows
STAH2S-BK



HAND-HAMMERED
STAINLESS STEEL

7



1 row
STAH1B-BK



2 rows
STAH2B-BK



HAND-HAMMERED
BRASS

**5 TOURING SYNTHETIC HEAD
WOOD TAMBOURINES**

SIZE 10"
MATERIALS Black plated steel
True Feel synthetic head
Wooden frame
FEATURES 1 Row and 2 row version
True Feel synthetic head
COLOUR R = Red

**6 SUPER-DRY STUDIO GOAT SKIN WOOD
TAMBOURINES, STAINLESS STEEL JINGLES**

SIZE 10"
MATERIALS Hand-hammered stainless steel
Hand selected goat heads
Wooden Frame
FEATURES Hand-hammered triangular jingles for an
extra sweet sound with short sustain
1 row and 2 row versions
COLOUR BK = Black

**7 SUPER-DRY STUDIO GOAT SKIN WOOD
TAMBOURINES, BRASS JINGLES**

SIZE 10"
MATERIALS Hand-hammered brass
Hand selected goat heads
Wooden frame
FEATURES Hand-hammered triangular brass jingles
for extra dry sound
1 row and 2 row version
COLOUR BK = Black



1 row
TA1AB

2 rows
TA2AB



1 row
TA1A-AB

2 rows
TA2A-AB



1 row
TA1M-SNT

2 rows
TA2M-SNT



1 row
TA1B-AB

2 rows
TA2B-AB

WOOD TAMBOURINES

MEINL's Wood Tambourines are made from a sturdy frame with jingles available in different materials, resulting in various sound possibilities. Their ergonomically shaped handle and light weight enable energetic playing.

1 REGULAR WOOD TAMBOURINES, STEEL JINGLES

SIZE 10"
MATERIALS Nickelsilver plated steel
Wooden frame
FEATURE 1 row and 2 row version
COLOUR AB = African Brown

2 REGULAR WOOD TAMBOURINES, ALUMINUM JINGLES

SIZE 10"
MATERIALS Aluminum
Wooden frame
FEATURE 1 row and 2 row version
COLOUR AB = African Brown

3 RECORDING-COMBO WOOD TAMBOURINES, DUAL-ALLOY JINGLES

SIZE 10"
MATERIALS Steel / solid brass
Wooden frame
FEATURES Dual-alloy jingles
1 row and 2 row version
COLOUR SNT = Super Natural

4 REGULAR WOOD TAMBOURINES, BRASS JINGLES

SIZE 10"
MATERIALS Solid brass
Wooden frame
FEATURE 1 row and 2 row version
COLOUR AB = African Brown

STUDIO & ARTISAN EDITION TAMBOURINES

1



HAND-HAMMERED STAINLESS STEEL

1 row
STA1S-BK

2 rows
STA2S-BK

2



HAND-HAMMERED BRASS

1 row
STA1B-BK

2 rows
STA2B-BK

3

NEW!



ERGONOMIC HAND GRIP



SOLID BRASS JINGLES



2 rows
AE-MTA2B



GERMAN CYMBAL BRONZE JINGLES



2 rows
AE-MTA2BO

1 SUPER-DRY STUDIO WOOD TAMBOURINES, STAINLESS STEEL JINGLES

SIZE 10"

MATERIALS Hand-hammered stainless steel
Wooden Frame

FEATURES Hand-hammered triangular jingles for an extra sweet sound with short sustain
1 row and 2 row versions

COLOUR BK = Black

2 SUPER-DRY STUDIO WOOD TAMBOURINES, BRASS JINGLES

SIZE 10"

MATERIALS Hand-hammered brass
Wooden frame

FEATURES Hand-hammered triangular brass jingles for extra dry sound
1 row and 2 row version

COLOUR BK = Black

3 ARTISAN EDITION TAMBOURINES

MEINL Artisan Edition Tambourines are proudly made for the most discerning musicians. We developed a special profile jingle for a fine and distinct sound. The attack is airy yet punctuated, with a medium sustain. Artisan frames are precision made from pure maple wood in a stable 9-ply construction. The hand grip is comfortable and secure.

SIZE 10"

MATERIALS Maple (*Adcer sp.*)

B: Solid brass jingles

BO: Cymbal bronze jingles

FEATURES Total unique tambourine sounds

Special profile jingles

Ergonomic hand grip

Detailed with ornamental heat-branded logo



NICKEL SILVER PLATED STEEL



2 rows
CTA2S-BK

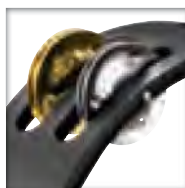

STEEL / SOLID BRASS



2 rows
CTA2M-BK



SOLID BRASS



2 rows
CTA2B-BK



HAND-HAMMERED STAINLESS STEEL



2 rows
CSTA2S-BK



HAND-HAMMERED BRASS



2 rows
CSTA2B-BK



THE HAND-HAMMERED JINGLES BRING A TRASHY FLAVOUR TO YOUR RHYTHM

COMPACT WOOD TAMBOURINES

Good sounds comes in small packages! MEINL Percussion offers a great line of Compact Wood Tambourines. Light, fast, and full of sound, they are available in five different versions.

SIZE 8"

MATERIALS Wooden frame

CTA2S-BK: Steel

CTA2M-BK: Steel / solid brass

CTA2B-BK: Solid brass

CSTA2S-BK: Hand-hammered stainless steel

CSTA2B-BK: Hand-hammered brass

FEATURES Compact size

Many jingle variations

COLOUR BK = Black

SEE THE DIFFERENCE !!!



Regular tambourine size 10",
16 pairs of jingles!



Compact tambourine in handy
size 8", 12 pairs of jingles!

THE 8" DIAMETER MAKES THEM
VERY COMPACT AND HANDY

HAND HELD ABS TAMBOURINES

1



NICKELSILVER
PLATED STEEL

TMT1BK



NICKELSILVER
PLATED STEEL

TMT1R

2



ALUMINUM

TMT1A-WH



ALUMINUM

TMT1A-B

3



STEEL / SOLID BRASS

TMT1M-WH

4



SOLID BRASS

TMT1B-BK

5



HAND-HAMMERED
STAINLESS STEEL

STMT1S-BK

6



HAND-HAMMERED
BRASS

STMT1B-BK

HAND HELD ABS TAMBOURINES

The MEINL hand held ABS Tambourines come with a padded ergonomic soft grip and are extremely light weight for long term playing comfort. Several jingle variations offer sounds ranging from dry and cutting to sweet and soft, helping every drummer find the right flavor for their rhythms.

FEATURES Padded soft grip for more playing comfort
Ergonomic design
Güiro style playing surface
"Sandwich" construction

1 REGULAR ABS TAMBOURINES, STEEL JINGLES

MATERIALS Nickelsilver plated steel
ABS plastic
COLOURS BK = Black
R = Red

2 REGULAR ABS TAMBOURINES, ALUMINUM JINGLES

MATERIALS Aluminum
ABS plastic
COLOURS B = Blue
WH = White

3 RECORDING-COMBO ABS TAMBOURINE, DUAL-ALLOY JINGLES

MATERIALS Nickelsilver plated steel and solid brass
ABS plastic
COLOUR WH = White

4 REGULAR ABS TAMBOURINE, BRASS JINGLES

MATERIALS Solid brass
ABS plastic
COLOUR BK = Black

5 SUPER DRY STUDIO ABS TAMBOURINE, STAINLESS STEEL JINGLES

MATERIALS Hand-hammered stainless steel
ABS plastic body
COLOUR BK = Black

6 SUPER DRY STUDIO ABS TAMBOURINE, BRASS JINGLES

MATERIALS Hand-hammered brass
ABS plastic body
COLOUR BK = Black



CHRIS COLEMAN, USA



JEAN PAUL GASTER, USA



TREVOR LAWRENCE JR., USA

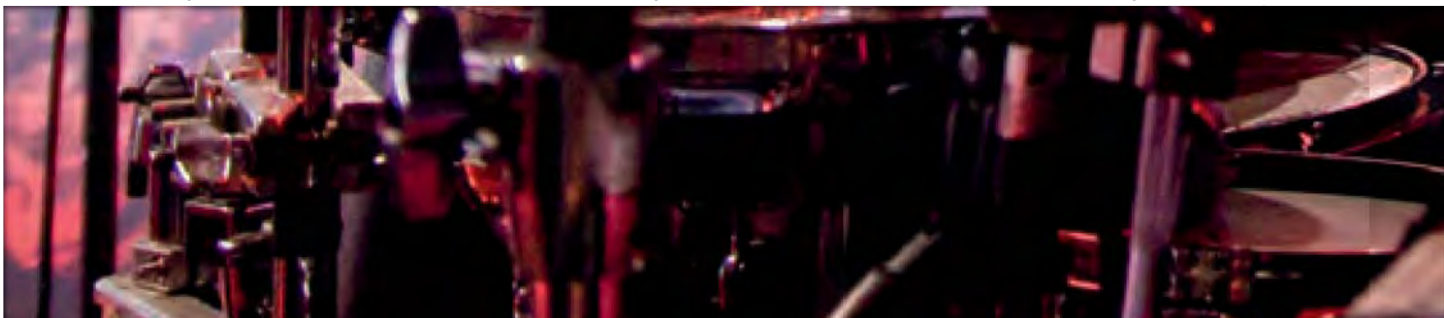

MAKE YOUR HATS GO CHING

KJ Sawka (Pendulum) uses a Professional Hihat Tambourine for special accents.



NORMAN BONINK, NETHERLANDS



FLO DAUNER, GERMANY



THOMAS LANG, AUSTRIA

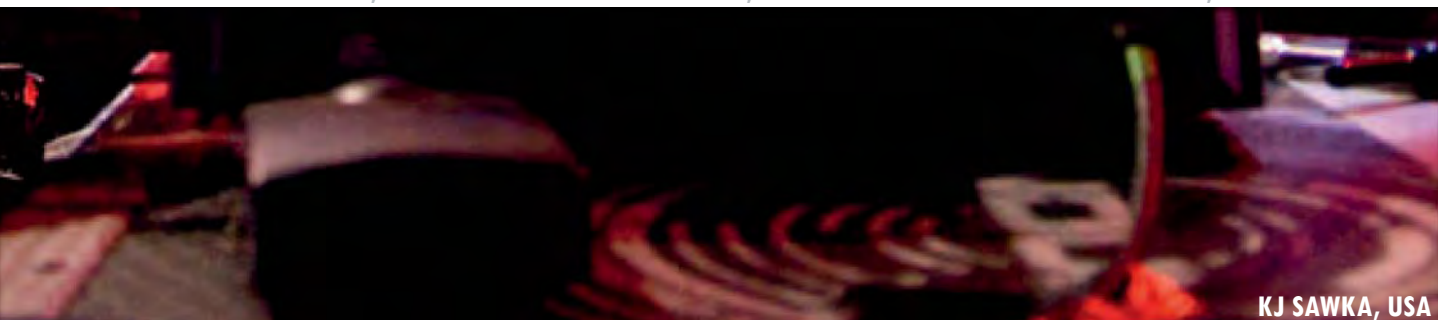

KJ SAWKA, USA



MOUNTABLE ABS TAMBOURINES

The MEINL mountable ABS Tambourines are built to stand up to the heaviest of hitters. They are easily mounted on a rod or stand to complete a drummer's setup. Several jingle variations offer sounds ranging from dry and cutting to sweet and soft, helping every drummer find the right flavor for their rhythms.

FEATURES Easily mountable
Ergonomic design
Güiro style playing surface
"Sandwich" construction

1 REGULAR ABS TAMBOURINES, STEEL JINGLES

MATERIALS Nickelsilver plated steel
ABS plastic
COLOURS BK = Black
R = Red

2 REGULAR ABS TAMBOURINE, ALUMINUM JINGLES

MATERIALS Aluminum
ABS plastic
COLOUR B = Blue

3 RECORDING-COMBO ABS TAMBOURINE, DUAL-ALLOY JINGLES

MATERIALS Steel / solid brass
ABS plastic
COLOUR WH = White

4 REGULAR ABS TAMBOURINE, BRASS JINGLES

MATERIALS Solid brass
ABS plastic
COLOUR BK = Black

5 SUPER-DRY ABS STUDIO TAMBOURINE, STAINLESS STEEL JINGLES

MATERIALS Hand-hammered stainless steel
ABS plastic
COLOUR BK = Black

6 SUPER DRY STUDIO ABS TAMBOURINE, BRASS JINGLES

MATERIALS Hand-hammered brass
ABS plastic body
COLOUR BK = Black

HIHAT TAMBOURINES & JINGLE STICKS

1



1 row
HTHH1BK



2 rows
HTHH2BK

2



1 row
THH1BK



1 row
THH1B-BK

3 **NEW!**



Steel /
Solid brass
MJS1BK

4



Steel
HJS1BK



Steel
HJS1R

5



Steel
JG1BK



Steel
JG1R



Aluminum
JG1A-B



Steel /
Solid brass
JG1M-WH



Solid brass
JG1B-BK

HIHAT TAMBOURINES 1 2

An easy access wing nut allows quick set-up, adjustment, or removal, completely independent from your cymbals. The Professional Hihat Tambourines feature a sturdy rubberized striking ring for special accents.

SIZE 5"

FEATURE Rubber padded surface

1 HEADLINER® HIHAT TAMBOURINES

MATERIAL Steel

2 PROFESSIONAL HIHAT TAMBOURINES

MATERIALS **THH1BK**: Steel
THH1B-BK: Solid brass

3 MULTI-JINGLE STICK

The MEINL Multi-Jingle Stick steps out into a new dimension. Steel and solid brass jingles are mounted on two intersecting faces and a single handle, for multi-directional dynamics. This opens up many new combinations of movement and sound.

MATERIALS ABS plastic
Steel and solid brass jingles

FEATURES Jingles mounted on two intersecting planes
Padded grip
Special playing techniques

4 HEADLINER® SERIES JINGLE STICKS

The MEINL Headliner® Series Jingle Sticks are an affordable alternative to a tambourine. Nice sound effects are also achieved when used as a stick on a drum.

MATERIALS Nickelsilver plated steel
ABS plastic

COLOURS BK = Black
R = Red

5 PROFESSIONAL JINGLE STICKS

The MEINL Professional Jingle Sticks create many interesting sound possibilities.

MATERIALS ABS plastic
JG1 = Nickelsilver plated steel
JG1A = Aluminum
JG1M = Steel solid brass
JG1B = Solid brass

FEATURES Padded grip
Guiro style playing surface

COWBELLS

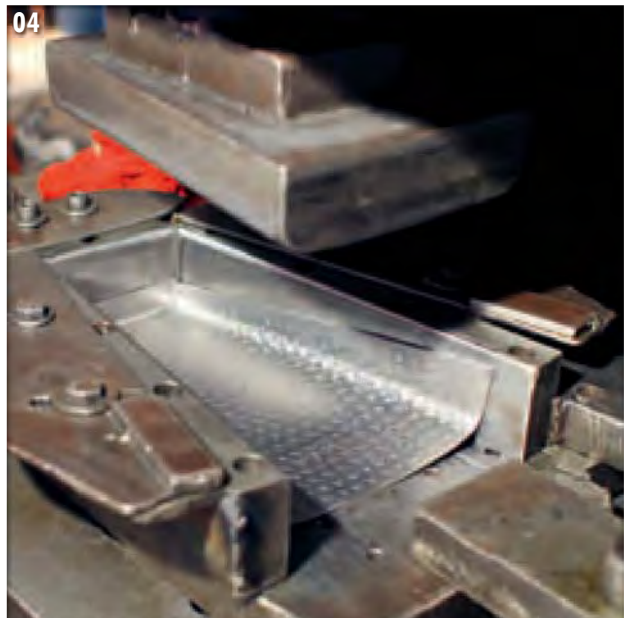
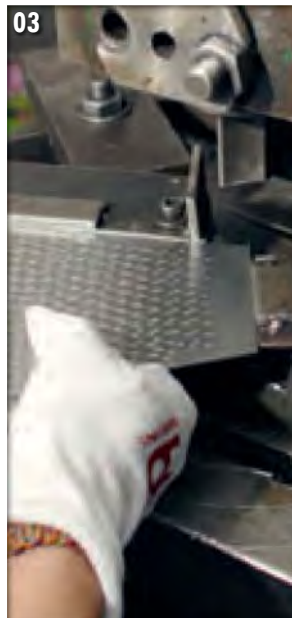
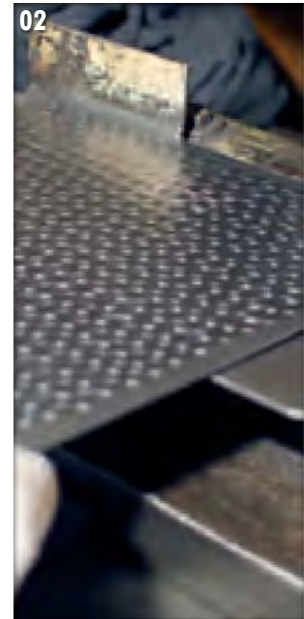
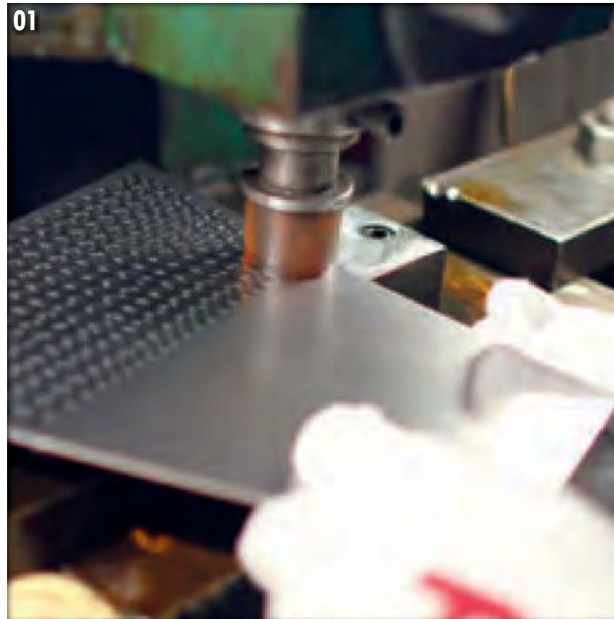

01 Cowbells are made in two halves. Here you see one side getting its hammered texture for an extra dry sound.

02 The MEINL logo is then stamped in the proper place.

03 The corners have to be cut out so the flat blank can be shaped into a cowbell.

04 A press forms the bell halves into shape.

05 Excess material is trimmed away.

06 The welds are brushed clean in preparation for the finish.



WE USE A DEEP PENETRATING AUTOMATIC FEED WELDING PROCESS FOR A SUPER STRONG SEAM.





ADJUSTABLE INTERIOR
DAMPENING MECHANISM
(PATENT PENDING)

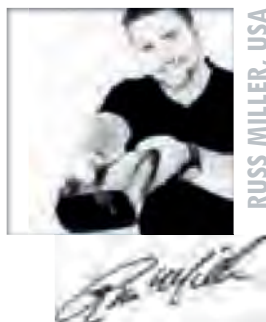

HAND BRUSHED GOLD



HAND BRUSHED STEEL



HAND BRUSHED COPPER



HAND BRUSHED STEEL

1 ARTIST SERIES COWBELL (RUSS MILLER) (PATENT PENDING)

The Russ Miller "Multi-Bell" enables multiple tones and is a breakthrough in versatility. You can adjust the amount of ring to your desired level with just a turn of a knob. This innovation brings out the most in a cowbell!

- MATERIAL** Special steel alloy
- FEATURES** Adjustable interior dampening mechanism (patent pending)
Hammered
- FINISH** Hand brushed black

2 ARTIST SERIES COWBELLS (KENNY ARONOFF)

Kenny Aronoff says: "my signature cowbells are the ultimate drummer's bells. Playing live they cut through and have very nice tones. Their recording characteristics are outstanding, too."

- MATERIAL** Special steel alloy
- FEATURE** Hammered
- FINISH** High polished chrome

3 HAMMERED COWBELLS

The strong fundamental tone of these cowbells make them a unique alternative to all other bells on the market. Each bell has its own character.

- MATERIAL** Special steel alloy
- FEATURE** Hammered
- FINISHES** Hand brushed copper, gold & steel

4 5 CHROME & STEEL FINISH COWBELLS

The pitches of these cowbells form a diatonic scale which makes it easy to use multiple bell combinations in any musical setting.

- MATERIAL** Special steel alloy
- FEATURE** Tonally matched
- FINISH** High polished chrome
Hand brushed steel

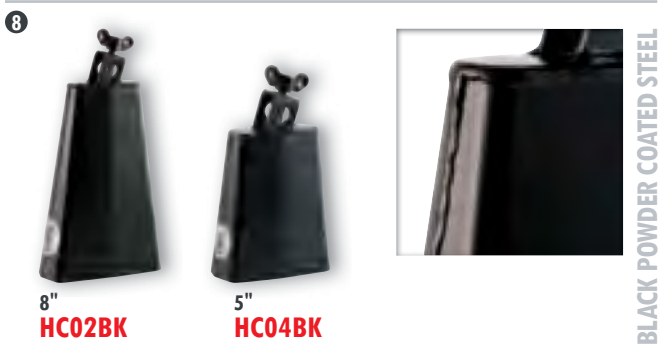

6 7 BLACK FINISH COWBELLS & TRIPLE BELL
 Their black powder coated steel produces a firm muffled sound.
MATERIAL Special steel alloy
FEATURE Muffled sound
FINISH Black powder coated steel

8 HEADLINER® SERIES COWBELLS
 Made from black powder coated steel, the MEINL Headliner® Series Cowbells produce a cutting and sharp sound. Whether used in a percussion setup or in a drum set configuration, they always add a special flavour to your groove.
MATERIAL Black powder coated steel
COLOUR BK = Black

9 HAND COWBELLS
 These cowbells easily cut through any high volume environment and are comfortable to hold due to their handy shape.
MATERIAL Special steel alloy
FINISH Hand brushed steel

10 HANDHELD COWBELLS
 The unique feature of the MEINL Handheld Models is a wide and comfortable grip. Ideal for street percussion.
MATERIAL Special steel alloy
FEATURE Comfortable holder
FINISH Hand brushed steel



1 NEW!



WELL DEFINED FUNDAMENTAL SOUND

Large
PMWB1-L

Medium
PMWB1-M

2



Large
MWB2BK

Medium
MWB1BK

3



High pitch
MPE1BK

Low pitch
MPE2R

4



NEW!

Traditional
FC1

Concert
FC2

5



NEW!

Traditional
HC1

1 PROFESSIONAL WOOD BLOCKS

Our Professional Wood Blocks are topped with Rosewood for a sharp, well defined fundamental sound.

SIZES Medium
Large

MATERIALS Rosewood top
Rubberwood body
(*Hevea brasiliensis* Muell.-Arg.)

FEATURES Well defined fundamental sound
Tiny rubber burling
Pilot holes to mount on a clamp

FINISH Matte

2 WOOD BLOCKS

The two versions of the MEINL Wood Blocks are tonally matched.

MATERIAL Rubber Wood
(*Hevea brasiliensis* Muell.-Arg.)

FEATURE Rounded playing surface

INCLUDES Wooden beater

COLOUR BK = Black, matte

3 PERCUSSION BLOCKS

The MEINL Percussion Blocks are made to withstand even the hardest hitting players.

MATERIAL PE

FEATURES **MPE1BK:**
High pitched sound and durability

MPE2R:
Low pitched sound and durability

INCLUDES Mounting Clamp

COLOURS BK = Black
R = Red

4 FINGER CASTANETS

Traditional Castanets are made in the style of southern Italian Tammurriata castanets. The concert version is made in the traditional Flamenco style.

SIZES **FC1:** Traditional
FC2: Concert

MATERIAL Rosewood (*Dalbergia sissoo*)

FEATURE Full and cutting resonance

5 TRADITIONAL HAND CASTANET

Traditional Hand Castanets are perfect for easy pick up and rapid, staccato play.

SIZE Traditional

MATERIAL Rosewood (*Dalbergia sissoo*)

FEATURES Balanced handle
Precisely formed contours for clear, distinct sound



STEPHAN MAASS, AUSTRIA

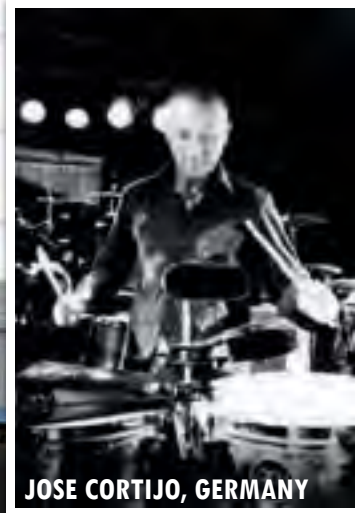

JOSE CORTIJO, GERMANY



THOMAS EBY, SWEDEN

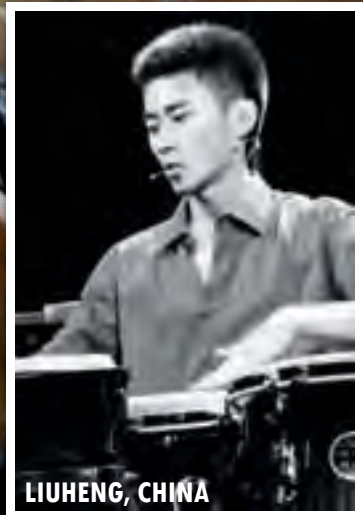

LIUHENG, CHINA

BILL SARAGOSA LINE



BILL SARAGOSA, NOT FROM THIS WORLD



FOR MORE INFO, SCAN THIS MEINL QR CODE WITH YOUR SMARTPHONE

1



CONE

5



**27 bells
BT27**

6



**14 bells
BT14**

7



**Large (low pitch)
WW2BK**

**Small (high pitch)
WW1BK**

3



TRIL

FILLED WITH WATER

4



GALAXY

VERY FUNKY

BILL SARAGOSA LINE 1 2 3 4

Instruments created by Bill Saragosa are very unique.

MATERIAL Special steel alloy

FEATURE Wide sound spectrum

FINISH Black nickel

1 CONE-STACK

FEATURE A set of two

2 HELIX BOWL (US patent)

INCLUDES Metal beater

3 LIQUID TRIANGLE

INCLUDES Metal beater

4 GALAXY

INCLUDES Metal beater

5 STAND ALONE BELL TREE

The MEINL Bell Tree has 27 solid brass bells mounted on a sturdy metal stand.

MATERIAL Solid brass bells

FEATURE Adjustable metal stand

INCLUDES Striker

6 HAND HELD BELL TREE

Our Hand Held Bell Tree has a cascade of 14 solid brass bells securely mounted on a wooden handle.

MATERIAL Solid brass bells

INCLUDES Striker

7 WAH-WAH TUBES

The MEINL Wah-Wah Tube is a tubular effect instrument that delivers smooth, bell like tones.

SIZES Small (high pitch)

Large (low pitch)

MATERIAL Aluminum

INCLUDES Rubber mallet

COLOUR BK = Black

8 HAND CHIMES

The three models of hand chimes are tonally matched.

SIZES 12 bars, 18 bars, 24 bars

MATERIAL Gold anodized aluminum alloy

9 PEG CHIMES

The Peg Chimes are extremely high pitched. They are perfect for special accents.

SIZE 12 pegs

MATERIAL Gold plated steel

8



12 bars
CH-H12

18 bars
CH-H18

24 bars
CH-H24

9



12 pegs
CH-HPEG

10



CH3

11

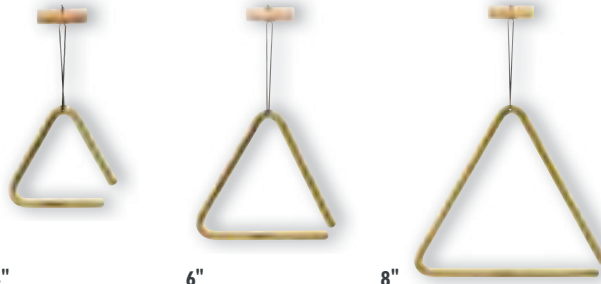

4"
TRI10B

6"
TRI15B

8"
TRI20B



FOR MORE INFO, SCAN THIS MEINL QR CODE WITH YOUR SMARTPHONE

12



7"
JCTRI20

NEW!

INVENTOR: JOSÉ J. CORTIJO

13



PFICY-2

15



FICY-14

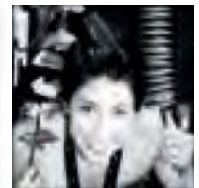

MARCIE CHAPA, USA

14



FICY-2

SPECIAL BRONZE ALLOY

10 TRI TONE CHIMES

The three free-floating bars create a very long sustain and are tonally matched.

- MATERIAL** Gold anodized aluminum alloy
- FEATURE** Mountable on all common L-rods
- INCLUDES** Wooden beater and holder

11 TRIANGLES

The solid brass triangles produce a nice sounding soft tone with a controlled sonic spectrum.

- SIZES** 4", 6", 8"
- MATERIAL** Solid brass
- INCLUDES** Wooden holder with braided nylon cord
Metal beater

12 UNIVERSAL TRIANGLE

The Universal Triangle is forged from one single piece of steel with a special texture for rasping effects.

- SIZE** 7"
- MATERIAL** Chrome plated steel
- FEATURES** Inner section for multiple tones
Textured leg for rasping strokes
- INCLUDES** Wooden holder with braided nylon cord
Metal beater

13 PROFESSIONAL FINGER CYMBALS

Made from a special bronze alloy and attached with a durable cord.

- SIZE** 2 5/8" diameter
- MATERIAL** Special bronze alloy
- FEATURES** Identical, high pitched sound
Durable cord

14 ORIENTAL FINGER CYMBALS

Measuring 2 3/8" in diameter, they are easy to hold and comfortable to play.

- SIZE** 2 3/8" diameter
- MATERIAL** Special bronze alloy
- FEATURES** Identical in pitch
Durable rubber band connection

15 HANGING FINGER CYMBALS

Strung on a durable cord and made from a special bronze alloy, 14 unique finger cymbals produce a shimmering chorus effect.

- SIZE** 2 3/8" diameter
- MATERIAL** Special bronze alloy
- FEATURES** Durable cord and shimmering sound



HIGH FREQUENCY CHIME

60 bars, double row
LC60HF



ALL BARS ARE ATTACHED THROUGH A NYLON CORD

66 bars, double row
CH66HF



COMES WITH STRIKER

36 bars, single row
CH36

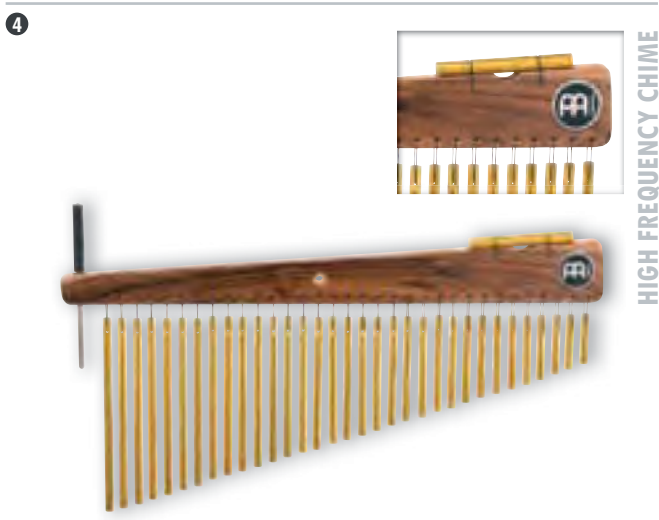

HIGH FREQUENCY CHIME

33 bars, single row
CH33HF

MEINL Chimes provide great tonal effect and are available in a wide assortment of sounds. All MEINL Chimes are made from a premium anodized aluminum alloy, and a well balanced wooden bar. Durable nylon cord is used to hang them securely.

1 ARTIST SERIES CHIMES (LUIS CONTE)

"I wanted a wide spectrum!" comments Luis Conte. "The shorter bars deliver great high pitched sounds. I can get a full and bright chime sound from the medium and low pitched bars. They sound perfect especially in the studio."

- SIZE** 60 bars, double row
- MATERIAL** Silver anodized aluminum alloy
- FEATURE** High frequency chime
- INCLUDES** Holder
Striker

2 CHIMES, 66 BARS

The 66 bar chimes produce a rich and full sound. They cut through any band setting.

- SIZE** 66 bars, double row
- MATERIAL** Gold anodized aluminum alloy
- FEATURE** High frequency chime
- INCLUDES** Holder
Striker

3 CHIMES, 36 BARS

With bars made from hand polished aluminum, these chimes produce a sound that is clear, bright, and rich in volume and expression.

- SIZE** 36 bars, single row
- MATERIAL** Silver anodized aluminum alloy
- INCLUDES** Holder
Striker

4 CHIMES, 33 BARS

The 33 bar chimes produce a very bright sound with a pronounced upper overtone spectrum. They are perfect for all live situations.

- SIZE** 33 bars, single row
- MATERIAL** Gold anodized aluminum alloy
- FEATURE** High frequency chime
- INCLUDES** Holder
Striker



LUIS CONTE, USA

5

12 bars, single row
CH12

6

27 bars, single row
CH27ST

7

27 bars, single row
CH27

8

27 bars
HCH1R

9

33 bars
HCH2BKSILVER ANODIZED
ALUMINUM ALLOY**5 CHIMES, 12 BARS**

The 12 bar chimes produce a beautiful, high pitched sound. Not too obtrusive, ideal for tasteful chime accents.

SIZE 12 bars, single row

MATERIAL Gold anodized aluminum alloy

6 STUDIO CHIMES, 27 BARS

The Studio Chimes feature slightly thinner bars for a full, rich and delicate sound.

SIZE 27 bars, single row

MATERIAL Gold anodized aluminum alloy

7 CHIMES, 27 BARS

The 27 bar chimes produce a full sound with a wide tonal spectrum. Ideal for smaller stages and club scenes.

SIZE 27 bars, single row

MATERIAL Gold anodized aluminum alloy

8 HEADLINER® SERIES CHIMES, 27 BARS

The MEINL Headliner® Series Chimes are a great and affordable addition to any percussion set-up! They are made from high quality materials and produce a full and warm chime sound.

SIZE 27 bars

MATERIAL Silver anodized aluminum alloy

9 HEADLINER® SERIES CHIMES, 33 BARS

This chime has 33 silver-anodized bars for a full sound spectrum. The curved black truss beam and the silver bar chimes look great in any percussion setup.

SIZE 33 bars

MATERIAL Silver anodized aluminum alloy



ADJUSTABLE NET FOR VARIOUS TENSIONS AND SOUND OPTIONS

CA7R



PORTS FOR MORE VOLUME (PATENTED)

Large
CA5BK-L

Medium
CA5BK

Small
CA5BK-S

3 **NEW!**



25 bells
SLB25



12 bells
SLB12



7 bells
SLB7

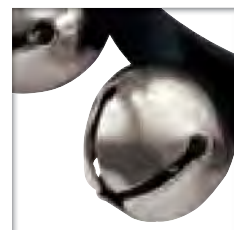

STEEL BELLS

1 CABASA, FIBREGLASS

The shape and function of the MEINL Fibreglass Cabasa equals a traditional gourd calabash.

MATERIAL Premium fibreglass

COLOUR R = Red

2 TURBO CABASAS (PATENTED)

The MEINL Turbo Cabasas are a great innovation, with significantly more volume than normal cabasas. This comes from the sound ports in the resonating chamber. The Turbo Cabasas bring the classic cabasa sound to a new level that will cut through any sonic environment.

SIZES Small, medium, large

MATERIALS Steel chain and stainless steel cylinder
Wooden handle with padded soft grip

FEATURE 5 sound ports on each side for more volume (CN, DE, US patent)

COLOUR BK = Black

3 SLEIGH BELLS

The MEINL Sleigh Bells ring rich and full, for a true sleigh bell sound. A positive, ergonomic grip assures dynamic control.

SIZES 7, 12, 25 bells

MATERIALS Steel bells
Wooden handle

FEATURES Ergonomic grip
True sleigh bell sound

KALIMBAS

1



FOR MORE INFO, SCAN THIS QR CODE OR CODE WITH YOUR SMARTPHONE



EXTRA WIDE TONGUES FOR COMFORT

CABASAS & KALIMBAS

Small
KA5-S

Medium
KA9-M

Medium
KA7-M-BK

NEW!

2



WIDE OPENING FOR GREAT WAH-WAH EFFECTS

Medium
KA9WW-BK

3



PICKUP SYSTEM WITH VOLUME CONTROL FROM Shadow

Medium
KA9P-AB

KALIMBAS 1 2 3

MEINL Kalimbas are great sounding melodic instruments with unique features. Solid construction, plated steel keys and an ergonomic shape makes them dependable musical tools. Also available with pickup system or wah-wah effect.

1 REGULAR KALIMBAS

The sound is pure joy, and a great addition to any percussion kit.

- SIZES** **KA5-S:** Small – g[#] c[#] f[#] c^{'''}
KA7-M-BK: Medium – e[#] g^d e^c a^a
KA9-M: Medium – a^c c^a A^f e^e b^b
- MATERIALS** Chrome plated steel
 Rubber Wood
 (Hevea brasiliensis Muell.-Arg.)

- FEATURES** Ergonomic shape
KA7-M-BK: Extra wide tongues for comfort

2 WAH-WAH KALIMBA

Everybody loves a little wha-wha, so we came up with a kalimba with a body-oriented sound hole in place of the traditional style. You can create a great wha-wha effect by simply bouncing the kalimba body on and off your belly as you play. The position is comfortable and natural, while the sound gets shifted in creative ways.

- SIZE** Medium – a^c c^a A^f e^e b^b
- MATERIALS** Chrome plated steel
 Rubber Wood
 (Hevea brasiliensis Muell.-Arg.)
- FEATURES** Ergonomic shape
 Wah-wah effect
- COLOUR** BK = Black

3 PICKUP KALIMBA

We put a pickup into our kalimba to boost the output, so your melody can carry on. The internal pre-amp means you won't have to worry about playing up close to the mike. An external volume knob lets you easily adjust to any situation.

- SIZE** Medium – a^c c^a A^f e^e b^b
- MATERIALS** Chrome plated steel
 Rubber Wood
 (Hevea brasiliensis Muell.-Arg.)
- FEATURES** Pickup system with external volume control from Shadow
 Sound port on upper surface
 Wah-wah effect
- COLOUR** AB = African Brown



CL1HW

CL1RW

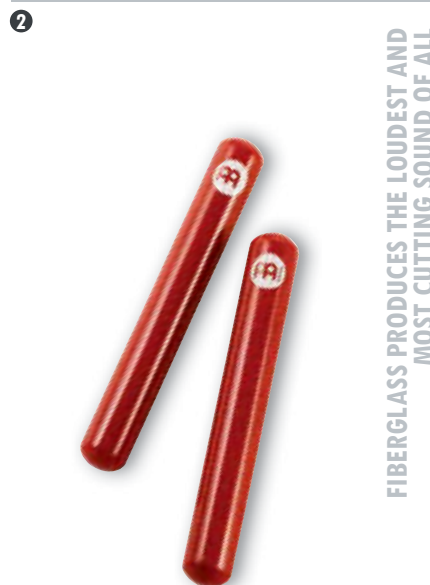

**Fiberglass
CL7R**

FIBERGLASS PRODUCES THE LOUDEST AND MOST CUTTING SOUND OF ALL



CL18

MADE FROM SUPERB, DENSE HARDWOOD



CL2HW



CL2RW



CL3HW



CL3RW



1 WOOD CLAVES, CLASSIC

The MEINL Classic Wood Claves are the most common claves and produce the classic cutting sound.

MATERIALS HW = Hardwood
RW = Redwood

FEATURE Solid body

2 FIBERGLASS CLAVES

Claves made from fiberglass produce the most penetrating, loud, and cutting sound of all.

MATERIAL Premium fiberglass

FEATURES Solid body
Cutting sound

COLOUR R = Red

3 CLAVES DE LUXE

Our Claves De Luxe are made from a superb, dense hardwood which delivers a cutting and bright tone.

SIZE 6 3/4" long

MATERIAL Dense hardwood

FEATURES Cutting sound
Convenient carrying

4 WOOD CLAVES, AFRICAN

African Claves are slightly larger and have a lower fundamental pitch. Additionally, the resonating body is larger than the striker. Available in two different versions: Solid and hollowed out body.

MATERIALS HW = Hardwood
RW = Redwood

FEATURES CL2 = Solid body
CL3 = Hollowed out body

SOUND EFFECTS

1



BI7RY



WA7BK



BI1NT



WA1NT



BI2NT



WA2NT

2



FR1NT

3



KO1AM

ERGONOMICALLY SHAPED HANDLE



KO2AM/BK

4



NI1AM

5



Fiberglass, black
RO1BK

FIBREGLASS DELIVERS A DRIER AND LOUDER SOUND



Wood, amber
RO2AM

WOOD PRODUCES A WARM CRISP TONE

1 BIRDS/WATERFALL

The MEINL Birds and Waterfall realistically imitate the sound of a flock of birds or a rippling waterfall. Fiberglass and wooden versions available.

MATERIALS BI7RY, WA7BK: Premium fiberglass
BI1NT, WA1NT, BI2NT, WA2NT: Rubber Wood (*Hevea brasiliensis* Muell.-Arg.)

FEATURES BI1NT, WA1NT, BI7RY, WA7BK
Durable cord
BI2NT, WA2NT
Handle made out of natural cord

COLOURS NT = Natural, BK = Black, RY = Red/Yellow

2 FOOT RATTLE

The Foot Rattle goes with everything. Marks pulse with moderate volume and warmth.

MATERIAL Rubber Wood (*Hevea brasiliensis* Muell.-Arg.)
FEATURE Hook and loop fastener
COLOUR NT = Natural

3 KOKIRIKOS

The Kokiriko originated in Japan as a sound effect instrument. It produces a rattling effect which can be an almost silent rustling to an extremely loud catter.

MATERIAL Wood
FEATURES KO1AM
Ergonomically shaped handle
Durable cord
KO2AM/BK
Ergonomically designed handgrips

Wide, stable binding strap in real leather
COLOURS AM = Amber, AM/BK = Amber/Black

4 THE NIGHT

When playing The Night, four solid steel balls hit a cylindrical metal rod in quick succession producing the unique sound of crickets.

MATERIALS Solid steel balls and cylinder
Wooden body

FEATURE Ergonomically shaped handle
COLOUR AM = Amber

5 THE ROARS

The MEINL Roar is available as a wood and as a fiberglass version. A rattling effect is achieved by striking the ball end against the palm of the hand.

MATERIALS Wood or premium fiberglass
FEATURE Solid construction

1



Spark shaker
SH16

CIRCULAR MOTION
ENABLES A UNIQUE
RATTLING

2



Spin spark
SH17

SCREW-MOUNTED DISC
ENABLES A TUNABLE
PITCH

3



Clamshell spark, set of two
SH22

HIGH PITCH & LOW PITCH

4



Headed spark
SH18

SENSATIONAL EFFECTS ARE PRODUCED WHEN
COMBINED WITH ANOTHER SPARK SHAKER



INVENTOR: BILL SARAGOSA

1 ORIGINAL SPARK SHAKER

The sparkling, chirping, splashing tones readily mix with almost any musical flavour. The pod-like shape fits easily into the hand and may be manipulated for many interesting effects. Spark Shakers may be played in pairs, or in combination with other shakers for even more variations.

SIZE Medium

MATERIALS Shaker: Coated steel

Pellets: Coated steel

FINISH Black nickel

2 SPIN SPARK SHAKER

The MEINL Spin Spark Shaker is equipped with a screw-mounted disc that adjusts and amplifies the characteristics of the fundamental pitch. When the disc is tight, the pitch is highest; and it deepens as

the disc is loosened. There is a distinctively pleasant supplemental timbre.

SIZE Medium

MATERIALS Shaker: Coated steel

Pellets: Coated steel

FINISH Black nickel

3 CLAMSHELL SPARK SHAKERS

Clamshell Spark Shakers have a single solid weld holding the two halves of the shell together like a hinge. When you squeeze the two halves together, you get a wildly variable pitch response. It comes in two pitches, for high-low combinations.

MATERIAL Steel

FEATURES Comes in a set of two

Wildly variable pitch response

FINISH Black nickel

4 HEADED SPARK SHAKER

One side of the MEINL Headed Spark Shaker is a drum head! Premium goatskin and a steel shell provide a rattling combination of crisp warm tones and a bright metal timbre.

SIZE Medium

MATERIALS Shaker: Coated steel

Pellets: Coated steel

Goat head

FEATURES Swirling effect

Variable pitch

FINISH Black nickel

ARTIST SERIES & STUDIOMIX SHAKERS

1



LUIS CONTE, USA

Luis Conte

SOFT STUDIO

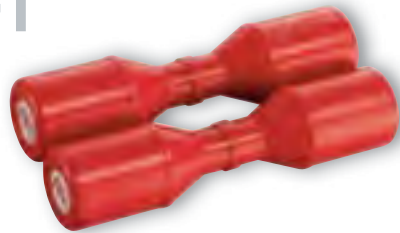

Studio shaker, red
SH5R



MED LIVE



Live shaker, black
SH4BK



LOUD STADIUM



Stadium shaker, grey
SH45GR

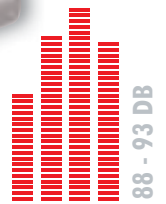

2



Large
SH12-L-BK



Medium
SH12-M-BK

NEW!

1 ARTIST SERIES SHAKERS (LUIS CONTE)

The three versions have been designed according to master percussionist Luis Conte's exact requirements. "My shaker sound is as smooth as silk" is how Luis described their sound.

- SIZE** Medium
- MATERIAL** Plastic
- FEATURE** Two individual shakers connected as one instrument
- COLOURS** **SH4BK** (Live Shaker): BK = Black
SH45GR (Stadium Shaker): GR = Grey
SH5R (Studio Shaker): R = Red

2 STUDIOMIX SHAKERS

The StudioMix Shakers have a crisp full sound and come in two sizes. The textured surface both enhances the timbre and enables a positive grip. Lightweight plastic body is virtually unbreakable.

- SIZES** Medium
Large
- MATERIAL** Plastic
- FEATURE** Textured surface for special sound and positive grip
- COLOUR** BK = Black



JUNIOR MORAES, BRAZIL

1



Small
SH8BK



Medium
SH88BK



Large
SH888BK



AMEL SERRA,
NETHERLANDS

2



Large
SH10-L-BK

3



Large
SH7-L-BK



Medium
SH7-M-BK

4



INVENTOR:
JUAN CARLOS MELIAN



Medium
JS88BK

BY TILTING THE SHAKER 90°
TO THE FRONT THE JINGLES
START TO CLICK ON THE BEAT

5

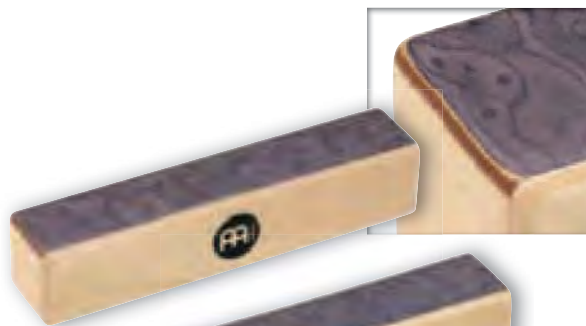

Large
SH15-L



Medium
SH15-M



Small
SH15-S

BLACK MAKAH-BURL

1 ALUMINUM SHAKERS, OCTAGONAL

MEINL's Octagonal Aluminum Shakers come in three different sizes. All have a broad dynamic range with lots of volume.

SIZES **SH8BK**: Small
SH88BK: Medium
SH888BK: Large

MATERIAL Aluminum
COLOUR BK = Black

2 STUDIO SHAKER

MEINL's Studio Shaker was designed to meet all the requirements necessary in today's session world. It delivers a very tasteful and delicate shaker sound with a warm overall tone and a very well balanced frequency spectrum.

SIZE Large

MATERIAL Plastic
COLOUR BK = Black

3 FIBERGLASS SHAKERS

These MEINL Shakers are made from premium fiberglass for more durability and better sound quality. They are light weight and very comfortable to play.

SIZES **SH7-M-BK**: Medium
SH7-L-BK: Large

MATERIAL Premium fiberglass
COLOUR BK = Black

4 ALUMINUM JINGLE SHAKER

The MEINL Aluminum Jingle Shaker (designed by Juan Carlos Melian) has two pairs of steel jingles which are attached in one row to an octagonal aluminum shaker.

SIZE Medium
MATERIALS Shaker: Aluminum
Jingles: Steel
COLOUR BK = Black

5 WOOD SHAKERS

Made from a combination of selected woods, these new MEINL Wood Shakers offer a nice array of alternative sounds.

SIZES **SH15-S**: Small
SH15-M: Medium
SH15-L: Large

MATERIALS Rubber Wood
(*Hevea brasiliensis* Muell.-Arg.)
Top and Bottom: Black Makah-Burl

FOR MORE INFO, SCAN THIS QR CODE
OR CODE WITH YOUR SMARTPHONE



6



Small
SH6-S-BK

TWO DIFFERENT MATERIALS
PRODUCE EXPERIMENTAL
SOUNDS

7



Medium
SH20BK

BY COVERING AND
UNCOVERING THE SOUND
HOLE, A "WAH-WAH"
EFFECT CAN BE ACHIEVED

8



Medium
SH3BK

LOUD AND PENETRATING
SOUND DUE TO THE
MANY HOLES

9



Large
SH9-L-S

10



Medium, black
SH21BK



Medium, grey
SH21GR

6 RAWHIDE SHAKER

The MEINL Rawhide Shaker combines two different materials into one unique instrument. It produces very experimental sounds and works perfectly in modern music productions.

SIZE Small

MATERIALS Plastic with natural rawhide side caps

COLOUR BK = Black

7 WAKAH SHAKER

The shaker has two chambers which are separated by a plastic membrane. By covering and uncovering the sound hole, a "wah-wah" effect can be achieved

SIZE Medium

MATERIALS Wooden body and plastic chamber

COLOUR BK = Black

8 LOOP SHAKER (US PATENT)

The MEINL Loop Shaker has a crackling bright sound with many dynamics, and is easy to control. It is very responsive to hand pressure and movement, giving it a soft or loud voice as needed.

SIZE Medium

MATERIAL Plastic

FEATURE Loud and penetrating sound due to the many holes (US patent)

COLOUR BK = Black

9 ALUMINUM SHAKERS, ROUND

The MEINL Round Aluminum Shakers were designed to cut through loud live music. Available are two different versions.

SIZE Large

MATERIAL Anodized aluminum

COLOUR S = Silver

10 U.F.O. SHAKERS

The black MEINL U.F.O. Shaker produces an extreme mellow and smooth sound and less attack, while the grey version has a crisper sound with more volume.

SIZE Medium

MATERIAL Plastic

COLOURS BK = Black

GR = Grey



Jumbo
MSM4

Traditional
MSM3

Mini
MSM2



Studio
PM1BK

Concert
PM2BK

Live
PM3BK

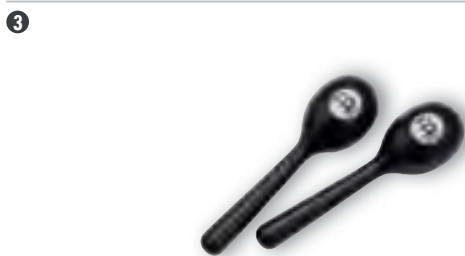

PEMBK



Oval
MWM1MC

Round
MWM2AM



MCL2BG

NEW POSSIBILITIES IN SOUNDS,
RHYTHMS, AND SHOWMANSHIP
INVENTOR:
DANY MORENO, SPAIN

1 RAWHIDE MARACAS

Rawhide Maracas are entirely made by hand and are offered in three different sizes for a wide sonic range.

SIZES **MSM2:** Mini
MSM3: Traditional
MSM4: Jumbo

MATERIALS Natural rawhide and wooden handle

2 STUDIO, CONCERT, LIVE MARACAS

This lightweight plastic maracas provide stability and a strong, projecting sound.

MATERIAL Plastic
FEATURE Ergonomically shaped handle
COLOUR BK = Black

3 PLASTIC EGG MARACAS

Made from special plastic material, the MEINL Egg

Maracas have a clear and crisp tone with a comfortable handle for absolute control.

SIZE 6"
MATERIAL Plastic
FEATURE Ergonomically shaped handle

4 WOOD MARACAS

The traditional MEINL Wood Maracas are available in both round and oval models. Both of these exhibit a traditional warm and rich sound.

MATERIAL Wood

5 MARACACLAVES

The MEINL Maracaclaves are an exciting hybrid percussion instrument. They are a pairing of full volume maraca "bulbs" mounted on solid American White Ash "handles". The result is a new way to combine the two

timbres inside an efficient set of movements.

MEINL Maracaclaves offer new possibilities in sounds, rhythms, and showmanship!

MATERIALS American Ash wood (*Fraxinus americana* L.)
Plastic shaker head

FEATURES Can be played like maracas and claves at the same time
Precise and cutting sounds
Durable construction
Detailed with logo heat-branded on handle

COLOUR BG = Beige

6 EGG SHAKER SET

Set of four Shaker Eggs fit all your needs in the studio or on the road.

MATERIAL Plastic
FEATURE Range of volume from soft to extra loud

HAND PERCUSSION EGG SHAKERS & RATTAN SHAKERS & GÜIROS

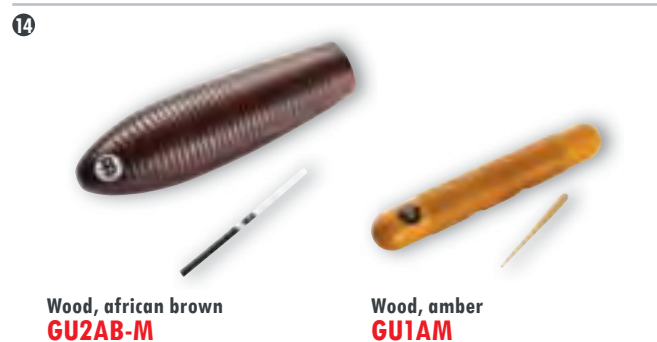
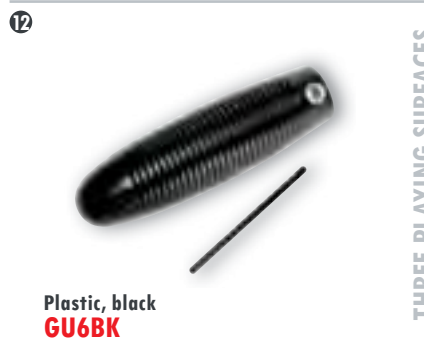

7 PLASTIC EGG SHAKERS
 The MEINL Plastic Egg Shakers are preferred due to their smooth and crystal clear sound. These have applications in practically any musical setting.
MATERIAL Plastic
COLOURS B = Blue, BK = Black, GREEN = Green, R = Red, Y = Yellow

8 WOOD EGG SHAKER
 The MEINL Wood Egg Shaker delivers a soft yet rich sound.
SIZE Jumbo
MATERIAL Wood
COLOUR BK = Black

9 DOUBLE SHAKER/GANZA
MATERIALS Rattan with coconut bottom

10 MERENGUE GÜIRA
 Our Merengue Güira is a robust, full size Güira with a precision-formed scraping surface.
MATERIAL Brushed steel
FEATURES Scraping surface with uniform raised bumps
 One-piece metal grip with welded flanges
INCLUDES ABS scraper MGS2

11 CAXIXIS
MATERIALS Rattan with coconut bottom

12 PLASTIC GÜIRO
MATERIAL High strength plastic
FEATURE Three striking surfaces rubber ringed grip holes
INCLUDES Plastic Scraper
COLOUR BK = Black

13 FIBERGLASS GÜIROS
MATERIAL Premium fiberglass
FEATURES Three striking surfaces
 Padded grip holes
INCLUDES Plastic scraper
COLOURS BK = Black, R = Red

14 WOOD GÜIROS
 The traditional MEINL Wood Güiros produce a warm and cutting sound.
MATERIAL Wood
FEATURES **GU1AM:** Grip holes
GU2AB-M: Three striking surfaces Grip holes
INCLUDES **GU1AM:** Wooden scraper
GU2AB-M: Plastic scraper
COLOURS AB-M = African Brown, matte
 AM = Amber

1



RA7BK



HOW WE MAKE IT

01 The synthetic didgeridoos are being prepared for hand painting. The black base colour is applied first.

02 Every MEINL Didgeridoo/Rainstick is a hand-painted unique piece of art.

03 You can see how much care and detail goes into each didgeridoo.

2



39"
RS1BK-L

24"
RS1R-M

16"
RS1BK-S

3



39"
SRS1R-L



1 RAINMAKER

The MEINL Rainmaker is uniquely different. Due to the circular construction, it can be mounted on a cymbal stand and by simply turning the instrument a drizzle can immediately change into the sound of a monsoon.

MATERIAL Premium fiberglass

FEATURE Circular construction

INCLUDES Ergonomically shaped handle

COLOUR BK = Black

2 WOOD RAINSTICKS

Natural Bamboo makes our Rainsticks pleasant effect instruments, with plenty of projection and long sustain. They may be played like big shakers as well.

SIZES 16" (40 cm)
24" (60 cm)
39" (100 cm)

MATERIAL Bamboo

COLOURS BK = Black
R = Red

3 SYNTHETIC RAINSTICK

The MEINL Synthetic Rainstick is light in weight and extremely durable.

SIZE 39" (100 cm)

MATERIAL Lightweight synthetic

COLOUR R = Red

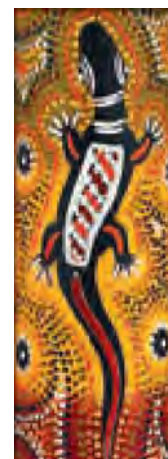

DIDGERIDOOS

1

FOR MORE INFO, SCAN THIS QR CODE OR CODE WITH YOUR SMARTPHONE



2



47"
DDG1-BK

47"
DDG1-R

3 **NEW!**



51"
SDDG1-BK

51"
SDDG1-R



36"–62"
TSDDG1-BK



TWO TELESCOPING SECTIONS

4



57"
PROFDDG1-BK

57"
PROFDDG2-BR

1 WOOD DIDGERIDOOS

These Didgeridoos are a great way to get started on the oldest wind instrument in the world. It makes a distinctive drone with harmonic overtones, and goes great with all kinds of percussion. Our didgeridoos are made from Bamboo.

SIZE 47" long (120 cm)

MATERIAL Bamboo

COLOURS BK = Black
R = Red

2 SYNTHETIC DIDGERIDOOS

The new MEINL Synthetic Didgeridoos are a modern twist on the traditional bamboo construction. They are extremely durable and are unaffected by weather so they are perfect for outdoor use.

SIZE 51" (130 cm)

MATERIAL Lightweight synthetic

COLOURS BK = Black
R = Red

3 TROMBONE DIDGERIDOO

The MEINL Trombone Dideridoo can vary in pitch like a slide trombone. One section has the mouthpiece and slides into the bell section. Pitch intervals are painted clearly on the side of the instrument. Hand finished with exotic Australian style dot painting.

SIZE 36"–62"

MATERIAL Premium fiberglass

FEATURES Two telescoping sections for variable pitch

Tuning from: G# G F# F E D# D C# C

COLOUR BK = Black

4 FIBERGLASS DIDGERIDOOS

Our Professional Didgeridoo is made from premium fiberglass for unsurpassed stability and long life. A flared bell enhances the sound projection, and the hand-painted designs make them truly beautiful.

SIZE 57" long (145 cm)

MATERIAL Premium fiberglass

FEATURES PROFDDG1-BK: D tone
PROFDDG2-BR: E tone

COLOURS BK = Black
BR = Brown

1



16"
CA16C

14"
CA14C

2



HAND HAMMERED

10"
CA10S

3



10"
CA10PH

QUICK RESPONSE WHEN
HIT BY A HAND



1 PERCUSSION CRASHES

The crashes are thin, tonally matched cymbals which can be played by hand or hit with a stick. They respond fast and decay quickly.

SIZES 14", 16"

MATERIAL B20 Bronze

FEATURES Hand-hammered
Brilliant finish
Fast response and attack
Quick decay

2 PERCUSSION SPLASH

The percussion splash is an extremely thin, quick sounding cymbal - perfect for fast percussive accents.

SIZE 10"

MATERIAL B20 Bronze

FEATURES Hand-hammered
Brilliant finish
Fast response and attack
Quick decay

3 PERCUSSION HIHAT

A specially designed hihat just for cajon players. It can be played by hand or with lighter sticks. The top is extremely thin for a fast, controlled response. Recommended for use with the MEINL Low Hat.

SIZE 10"

MATERIAL B20 Bronze

FEATURES Can be played by hand or with lighter sticks
Recommended for use with the MEINL Low Hat



YOGI JOKUSCH, GERMANY

4

18"
CA18CR

5



BUILT-IN JINGLES

14"
CA14PJB**4 TIMBALES CRASH/RIDE**

It's the perfect cymbal for timbale playing. It has a loud, penetrating bell and a full, warm crash sound.

SIZE 18"
MATERIAL B20 Bronze
FEATURES Hand-hammered
 Brilliant finish
 Cutting bell sound
 Great crash sound

5 PERCUSSION JINGLE BELL

A great cymbal with an exotic sound. Six pairs of jingles attached to this cymbal produce a rattling effect.

SIZE 14"
MATERIAL B8 Bronze
FEATURES Precisely hammered
 Built in jingles



1



Black
TBRS-BK **Red**
TBRS-R

3



5/16" x 15"
TS5/16 **3/8" x 15"**
TS3/8 **7/16" x 16"**
TS7/16 **1/2" x 16"**
TS1/2

4



Long
SST1-L **Regular**
SST1-R **Short**
SST1-S **Sevenfold**
SST7 **Sixfold**
SST6 **Triple**
SST3 **Triple short**
SST3-S

2



FDT5



INVENTOR: THÓRRALF SCHUH



FDT4



FDT2



FDT3



FDT1

1 TAMBORIM STICKS

The MEINL Tamborim Sticks have three balanced, flexible plastic rods in a handy size.

MATERIAL Plastic

COLOURS BK = Black
R = Red

2 BODHRAN TIPPERS

The MEINL Bodhran Tippers come in five different styles, each with its own characteristic. They range from thin and light, to thick and full bodied. A special tipper with leather whips was designed by Thórralf Schuh.

MATERIAL Ash Wood

COLOUR AB = African Brown

3 TIMBALE STICKS

The MEINL Timbale Sticks are made out of the finest hand-selected Hickory Wood and are available in four different sizes.

MATERIAL Hickory Wood

SIZES **TS5/16:** 5/16" x 15",
TS3/8: 3/8" x 15",
TS7/16: 7/16" x 16",
TS1/2: 1/2" x 16"

4 SAMBA STICKS

MEINL offers a wide assortment of Samba Sticks for Tamborims, Repiniques, and other Samba instruments in order to achieve their authentic sounds.

MATERIAL Plastic

SIZES **SST1-S:** Stick, short version
SST1-R: Stick, regular version
SST1-L: Stick, long version
SST3-S: Triple stick, short version
SST3: Triple stick
SST6: Sixfold stick
SST7: Sevenfold stick

5



2" felt beater
SB1

2" felt beater
SB2

2 1/2" felt beater
SB3

2" leather beater
SB4

3" bushy felt beater
SB5

Wood beater
SB6

Two 2 1/2" felt beater
SB3-D

Two 2" felt beater
SB2-D

6



COW1

COW2

COW1BK

RIBBED GRIP

8

NEW!



Wood
MGS1

ABS
MGS2

7



Rattan
SPARE-10

Mahogany Wood
SPARE-23

5 SAMBA BEATERS

MEINL offers a wide assortment of Samba Beaters for Surdos and Repiniques in order to achieve their authentic sounds. All beaters are made from high quality materials to assure comfortable playing.

- SB1:** 15" long, aluminum stick with 2" felt beater
- SB2:** 16" long, wood stick with 2" felt beater
- SB2-D:** 16" long, wood stick with two 2" felt beater
- SB3:** 16" long, wood stick with 2 1/2" felt beater
- SB3-D:** 16" long, wood stick with two 2 1/2" felt beater
- SB4:** 16" long, wood stick with 2" leather beater
- SB5:** 16" long, wood stick with 3" bushy felt beater
- SB6:** 16" long, wood stick

6 COWBELL BEATERS

MEINL offers a regular and professional cowbell beater for more sound options.

- MATERIAL** Rubber Wood (*Hevea brasiliensis* Muell.-Arg.)
- FEATURES** Ribbed grip
Padded beater section

7 TALKING DRUM BEATERS

The curved playing end of the Talking Drum Beaters enables ideal positioning to strike the drum head, held near the player's body.

- SPARE-10:** Rattan
- SPARE-23:** Mahogany Wood

8 GÜIRA SCRAPERS

MEINL offers a wooden and a ABS Güira Scraper for more sound options and different playing techniques.

- MATERIALS** **MGS1:** Ergonomic wooden grip
- MGS2:** Sanded ABS grip
Steel rods

1



Black powder coated

Chrome plated

Gold tone

Black powder coated
 For Marathon® Classic/Designer Series
 For Luis Conte Artist Series
ST-MCC11BK: 11"
ST-MCC1134BK: 11 3/4"
ST-MCC1212BK: 12 1/2"

Chrome plated
 For Floatune Series
ST-FL10CH: 10"
ST-FL11CH: 11"
ST-FL12CH: 12"
ST-FL13CH: 13"

For Professional Series
 For Fibercraft Series
ST-MP11CH: 11"
ST-MP1134CH: 11 3/4"
ST-MP1212CH: 12 1/2"

QUICK AND EASY HEIGHT ADJUSTABILITY (GERMAN PATENT)

3



Chrome plated
TMC-CH

COMPATIBLE
 FOR ALL SIZES!

THE LIGHTWEIGHT STAND CAN BE FOLDED TO A
 COMPACT UNIT WHICH REQUIRES LITTLE SPACE (US PATENT)

2



Black powder coated
ST-HEBK

Chrome plated
ST-HECH

Gold tone
ST-HEG

EASY AND EFFECTIVE
 HEIGHT EXTENSION

1 STEELY II CONGA STANDS (PATENTED)

The MEINL Steely II Conga Stands are available for all MEINL Professional Series Congas.

MATERIAL Steel

FEATURES Metal spike attachment on each leg
 L-shaped legs (DE, TH, US patent)
 U-shaped notch for quick set up and breakdown (US patent)
 Ergonomic arched rubber bracing for more stability (CN, DE, LU, FR, UK, US patent)
 Notches for quick height adjustability (German patent)

INCLUDES Allen wrench

2 STEELY II CONGA STAND HEIGHT EXPANDER SETS (GERMAN PATENT)

These innovative add-ons to the MEINL Steely II Conga Stands allow an easy and effective height extension, which provides a more comfortable playing position for taller congueros.

MATERIAL Steel

FEATURE Easy and effective height extension

INCLUDES Mounting screws

Allen wrench

FINISHES Black powder coated

Chrome plated

Gold tone

3 PROFESSIONAL CONGA STAND (US PATENT)

The Professional Conga Stand is unique with respect to design and function. It was especially developed to accommodate the rigors of professional road use, where fine adjustment and durability are demanded.

MATERIAL Chrome plated steel

FEATURES Unique design

Rubber padded crossbeams

Fully height adjustable

Folds up to a compact unit

INCLUDES Allen wrench

Memory locks

STANDS & TABLES BONGO STANDS



**Black powder coated
THBS-BK**



**Chrome plated
THBS**

AN INNOVATIVE DESIGNED BRACKET
ENABLES QUICK SET UP (PATENTED)



**Chrome plated
TMB**

PADDED T-SHAPED TUBE FOR MORE STABILITY



**Chrome plated
TMB-S**

A STABLE METAL CLAMP HOLDS
THE ENTIRE UNIT IN PLACE

LOW HEIGHT FOR
SEATED PLAYERS

1 HEADLINER® SERIES BONGO STANDS (CN, DE, US PATENT)

These bongo stands combine easy handling and functionality with reliability and sturdy construction. A newly designed bracket enables extremely quick and easy mounting, yet holds the entire bongo securely in place.

MATERIAL Steel

FEATURES Quick set up
Easy handling
Reliable placement
Double braced tripod stand
Fits all common bongos

INCLUDES Wrench

COLOURS THBS = Chrome
THBS-BK = Black

2 PROFESSIONAL BONGO STAND

The MEINL Bongo Stand features a new design concept and simple functionality. The bongo is placed on a padded T-shaped tube and secured with a convenient knob screw. A stable metal clamp holds the entire unit securely in place.

MATERIAL Chrome plated steel

FEATURES Padded T-shaped tube
Fully height- and angle adjustable
Double braced tripod legs
Fits all common bongos

INCLUDES Allen wrench
Memory locks

3 PROFESSIONAL BONGO STAND FOR SEATED PLAYERS

This version of MEINL's Professional Bongo Stand has all the features of the regular model. However, it can be placed low enough to be comfortably played sitting down in the traditional position.

MATERIAL Chrome plated steel

FEATURES Seated playing position possible
Padded T-shaped tube
Fully height- and angle adjustable
Double braced tripod legs
Fits all common bongos

INCLUDES Allen wrench
Memory lock

1



Chrome plated
ST-DJEMBE



ADJUSTABLE TO ACCOM-
MODATE VARIOUS DJEMBE
SIZES USING THREE SPACERS



QUICK AND EASY
HEIGHT ADJUSTABILITY
(GERMAN PATENT)

2



Chrome plated
TMD



LENGTH ADJUSTABLE FOR
VARIOUS DJEMBE SIZES

3



Chrome plated
TMTS

THREE-ARM BASKET HOLDS
THE HAND-BALE SECURELY

4



Chrome plated
MLH

SPECIAL LOW HEIGHT

1 STEELY II DJEMBE STAND (PATENTED)

The Steely II Djembe stand features all of the same designs as the Steely II Conga stands. It can be adjusted to accommodate various djembe sizes using three spacers and is fully height adjustable. It is perfect for drum circles and other street percussion activities.

MATERIAL Chrome plated steel

FEATURES Metal spike attached to each leg
L-shaped legs (DE, TH, US patent)
U-shaped notch for quick set up and breakdown (US patent)
Ergonomic arched rubber bracing for more stability (CN, DE, LU, FR, UK, US patent)
Notches for quick height adjustability (German patent)
Adapts to different djembe sizes

INCLUDES Allen wrench
3 spacers

2 PROFESSIONAL DJEMBE STAND

The MEINL Djembe Stand was designed to firmly hold any djembe in the traditional playing position. A nylon strap is secured around the drum and two rubber padded u-shaped hooks slide into the bottom of the shell. It can be angled, and is fully height adjustable.

MATERIAL Chrome plated steel

FEATURES Rubber padded hooks
Fully height- and angle adjustable
Double braced tripod legs

INCLUDES Allen wrench
Memory lock

3 HAND-BALE STAND

Our new Hand-Bale Stand is double-bracketed and fully adjustable. The Hand-Bale is held securely in a rubber tipped three arm basket.

MATERIAL Chrome plated steel

FEATURES Quick set up
Rubber-tipped three arm basket
Easy handling
Double braced tripod stand

4 LOW HAT

The Meinl Low Hat has been designed with a special low height, made just for cajon players. It is recommended for use with the Meinl Candela 10" Percussion Hihat.

MATERIAL Chrome plated steel

FEATURES Special low height
Made just for cajon players

STANDS & TABLES CHIMES & DOUMBЕК/IBO & PERCUSSION STANDS

1



Chrome plated
TMCH



SPECIALLY DESIGNED TO HOLD
CHIMES, NOT CYMBALS

2



Chrome plated
TMID



FOAM PADDED RING

3



Chrome plated
TMPS



DIFFERENT RODS
FOR ALL NEEDS



BERTIL MARK, GERMANY

1 CHIMES STAND

Our Chimes Stand is a fully-adjustable, double braced tripod stand, specially designed for mounting bar chimes just the way you want them to be held! Made from sturdy chrome-plated steel for dependability. Special padding eliminates unwanted movement, and rubber feet prevent slipping.

MATERIAL Chrome plated steel

FEATURES Full angle and height adjustability
Secure angle clamps
Telescoping stem

2 PROFESSIONAL DOUMBЕК/IBO STAND

This Stand was designed to enable playing an Ibo Drum or a Doumbek in ways other than simply being placed in one's lap, such as standing up or incorporating it into a percussion set up. It can be angled and is fully height adjustable.

MATERIAL Chrome plated steel

FEATURES Foam padded ring
Fully height- and angle adjustable
Double braced tripod legs

INCLUDES Allen wrench
Memory lock

3 PERCUSSION STAND

The MEINL Percussion Stand is a universal device which offers a variety of set up solutions for both drummers and percussionists. It is fully height adjustable and features both quick locks and memory locks for a quick set up.

MATERIAL Chrome plated steel

FEATURES Height adjustable
Double braced tripod legs

INCLUDES Allen wrench
Memory locks
2 straight rods
2 angled rods
2 Z-shaped rods

ANGLE ADJUSTABLE
TOP BAR

HEAVY DUTY
CONSTRUCTION

COLOUR DOESN'T INTERFERE
WITH STAGE LIGHTING

HEIGHT ADJUSTABILITY
AT ALL POINTS

FABRIC ANTI-SLIP
SURFACE

STRONG MOUNTING CLAMPS
ENSURE A STABLE SET UP

Black powder coated
TMPWS

PERCUSSION WORKSTATION

Made with great attention to detail, the MEINL Percussion Workstation has been designed to be customized according to the player's demand. With the majority of its colour being black, the MEINL Percussion Workstation will blend in nicely with the overall stage design and won't interfere with the lighting and design engineers' concepts.

MATERIAL Black powder coated steel

FEATURES Fully height adjustable
Angle adjustable top bar
Fabric anti-slip surface
Heavy duty construction
Infinitely expandable
Fabric anti-slip surfaces
Colour doesn't interfere with stage lighting

INCLUDES 1 pc 22" x 24" padded fiberglass percussion table
2 pcs 18" x 12" padded fiberglass percussion tables (attachable)
1 pc 30" vertical bar
2 pcs 15" vertical bars (attachable)
4 pcs straight rods with hook
3 pcs angled rods with hook
1 pc Z-shaped rod with hook



CRISTIAN LA TORRE, CHILE

STANDS & TABLES PERCUSSION & ERGO TABLES

1

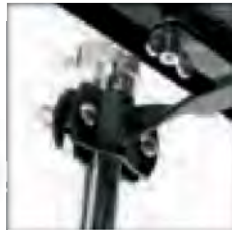

STRONG MOUNTING CLAMP



FABRIC ANTI-SLIP SURFACE

12" x 12"
MC-PTS

18" x 12"
MC-PT

2



16" x 22"
TMPTS

ALL MEINL TRIPOD STANDS ARE EQUIPPED WITH MEMORY- AND QUICK LOCKS

STANDS & TABLES

3



20" x 34"
TMPETS

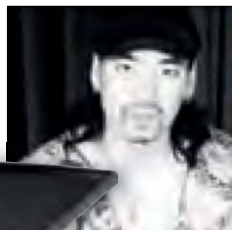

INVENTOR:
TAKU HIRANO, USA



ERGONOMIC SHAPE FOR MORE EFFICIENCY



ROLAND PEIL, GERMANY

1 PERCUSSION TABLES

These Percussion Tables are made from durable fiberglass and offer enough room for all common hand percussion instruments. It can be attached to all common stands. Through its innovative design the angle of the table can be adjusted.

SIZES **MC-PT:** 18" x 12"
MC-PTS: 12" x 12"

MATERIAL Premium fiberglass

FEATURES Fabric anti-slip surface
Adjustable angle
Strong mounting clamp

2 PERCUSSION TABLE STAND

Our Percussion Table Stand offers enough room for all common hand percussion instruments. It is fully height adjustable and has a fabric anti-slip surface.

SIZE 16" x 22"

MATERIALS Table: Premium fiberglass
Stand: Chrome plated steel

FEATURES Fabric anti-slip surface
Fully height adjustable
Double braced tripod legs

INCLUDES Allen wrench
Memory lock

3 ERGO TABLE

The curved shape helps you to fit it into your set-up with no space wasted, while keeping everything within easy reach. The inner raised edge is padded, so that instruments may be picked up and set down with an absolute minimum of contact noise. Double braced legs keep it all secure and stable.

SIZE 20" x 34"

MATERIALS Table: Premium fiberglass
Stand: Chrome plated steel

FEATURES Fabric anti-slip surface
Padded edge
Fully height adjustable
Ergonomic shape for more efficiency
Double braced tripod legs

INCLUDES Allen wrench
Memory lock

1



Frame Drum Holder
MC-FDH

FULLY ADJUSTABLE FOR ANY FRAME DRUM SIZE

2



Tambourine Holder
MC-TH

PADDED SURFACE AGAINST RATTLING

3



Wood Block Holder
MWBH1

4

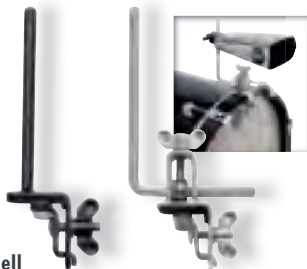

Cowbell Bass Drum Holders
MC-STBD

MC-BD

5



Chimes Holders
MC-CHL



MC-CH

6



Triangle Holder
MC-TRI

7



Shaker Holder
MC-SH

INVENTOR: JEN LOWE

8

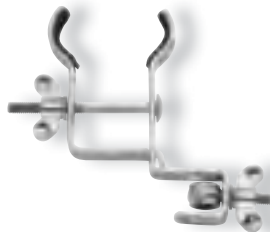

Guiro Holder
MC-GU

9

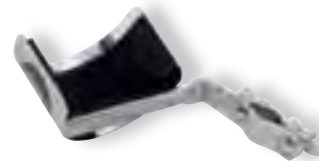

Cabasa Holder
MC-CA

10



Ibo Holder
TMIH

ENABLES TO PLAY THE IBO WITH BOTH HANDS ON A TABLE

11



Drumstick Holder
MEINL
MC-DSH



Drumstick Holder
Jawbreaker
MC-DSH-JB

HOLDERS

MEINL offers a wide range of holders and other hardware for several instruments or needs. Smart designed and practical in use.

MATERIAL Chrome plated steel
(if not differently indicated)

1 FRAME DRUM HOLDER

MATERIALS Anodized aluminum
Chrome plated steel
FEATURE Fully adjustable

2 TAMBOURINE HOLDER

FEATURES Rubber pads against scratching
Padded surface against rattling

3 WOOD BLOCK HOLDER

4 COWBELL BASS DRUM HOLDERS

MATERIALS **MC-BD:** Chrome plated steel
MC-STBD: Black powder coated steel
FEATURES Fully adjustable
Rubber pads against scratching
INCLUDES L-shaped rod

5 CHIMES HOLDERS

SIZES Regular
Large
FEATURES Knurled surface
Foam washer

6 TRIANGLE HOLDER

FEATURES Knurled surface
Nylon cord

7 SHAKER HOLDER

FEATURES Rubber pads against scratching
Length adjustable
Strong mounting clamp

8 GUIRO HOLDER

FEATURE Rubber pads against scratching

9 CABASA HOLDER

FEATURES Strong mounting clamp
Padded surface

10 IBO HOLDER

MATERIAL Black powder coated steel
FEATURES Allen wrench
Foam padded base

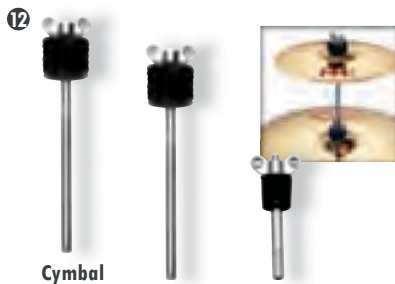

Cymbal Stackers
MC-CYS MC-CYS8 MC-CYS8-S



Cymbal Holder
MC-CY



Cymbal Attachment
MCA

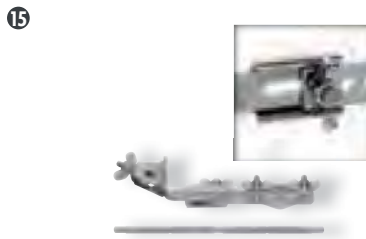

Multi Clamp, one mount
MC-1

LENGTH ADJUSTABLE FOR MORE FLEXIBILITY



Multi Clamp, two mounts
MC-2

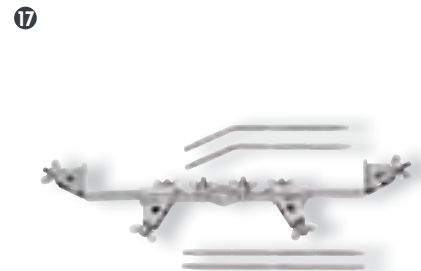

Multi Clamp, four mounts
MC-4



Straight rod **MC-R1** **Angled rod** **MC-R2** **Z-shaped rod** **MC-R3**



Clamp
CLAMP

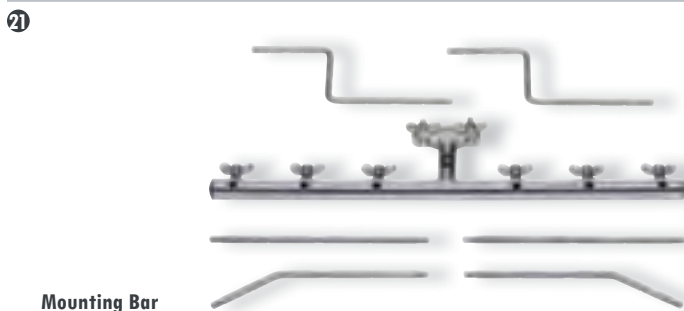

Mounting Bar
PMC-6



FITS ON ALL COMMON BASS DRUM PEDALS AND FIRMLY HOLDS COWBELLS, BLOCKS, OR TAMBOURINES

Pedal Mount
PM-1

STRONG MOUNTING CLAMP

11 DRUMSTICK HOLDERS

MATERIAL Black textile pouch
FEATURE Strong mounting clamp
FINISHES **MC-DSH:** MEINL
MC-DSH-JB: Jawbreaker motif

12 CYMBAL STACKERS

SIZES **MC-CYS:** ø 6 mm, long
MC-CYS8: ø 8 mm, long
MC-CYS8-S: ø 8 mm, short
FEATURE Felt washers

13 CYMBAL HOLDER

FEATURES Knurled surface
 Felt washers

14 CYMBAL ATTACHMENT

FEATURES Multi-clamp
 Cymbal boom arm

MULTI CLAMPS 15 16 17

FEATURES Length adjustable
 Strong mounting clamp

15 MULTI CLAMP, ONE MOUNT

INCLUDES Straight rod

16 MULTI CLAMP, TWO MOUNTS

INCLUDES 2 straight rods

17 MULTI CLAMP, FOUR MOUNTS

INCLUDES 2 straight rods
 2 angled rods

18 RODS

SHAPES Angled rod, Straight rod, Z-shaped rod
FEATURE Knurled surface

19 CLAMP

FEATURE Compact and solid design

20 PEDAL MOUNT

MATERIAL Black powder coated steel
FEATURES Height adjustable legs
 Metal spikes attached to the bottom
INCLUDES 2 differently sized L-rods

21 MOUNTING BAR, SIX PCS.

INCLUDES 2 straight rods
 2 angled rods
 2 Z-shaped rods



22" HEAD-69 20" HEAD-68 18" HEAD-67 16" HEAD-66



KES-01



HAM1BK

EASY MOUNTABLE



CSP

FITS UNDER ANY CONGA



MCR-BK

COMES IN A SET OF 4



CAJ-PAD



HEAD-79

NEW!

1 NAPA HEADS

The MEINL Napa Heads feature a two-layer construction with a strong, thin Mylar (plastic) under layer, and a soft Napa surface, securely bound together in a metal hoop.

SIZES 16", 18", 20", 22"

MATERIALS Nylon and leather cloth

FEATURE Bonded in a hoop

COLOUR BK = Black

2 KESSING

The Kessing is a traditional djembe accessory that provides a dry rattling accompaniment to the drum. It slides securely into the webbing and is removable.

SIZE Medium

MATERIAL Aluminum

3 HANDMATE

The MEINL Handmate is a professional cowbell beater which can be mounted in a set-up. This allows hitting the cowbell by hand while playing another instrument.

MATERIAL Steel construction with a wooden ball

FEATURE Fully adjustable

4 CONGA SOUND PLATE

The MEINL Conga Sound Plate is a sturdy wooden disc that provides a hard sound reflective surface under your conga.

SIZE 13 1/4"

MATERIAL Rubber Wood
(*Hevea brasiliensis* Muell.-Arg.)

5 CONGA RISERS

The MEINL Conga Risers are sturdy rubber feet that raise your drums off the floor to allow maximum sound projection. A set of four provides a stable base on any surface.

MATERIAL Sturdy Rubber

FEATURES Comes in a set of four

Flexible construction

COLOUR BK = Black

6 CAJON PAD

The MEINL Cajon Pad is the optimal cushion for our Headliner® Series Cajons. It assures more comfort and a safe seat while playing the instrument.

SIZE 10" x 10"

MATERIAL Soft foam



SBH



SB-R



MDR-ZB

MDR-C1

MDR-BK

MDR-JB



MDJS1

ADJUSTABLE STRAPS



MQSM



MDGFL

MDG

7 MESH HEAD FOR TAMBORIMS

The Mesh Head meant for the serious player who wants to perfect their Tamborim technique. Hours of quiet play are possible without sonic overload.

SIZE 6" diameter
MATERIAL Mesh head

8 SURDO BEATER HOLDER

Keep your Surdo Beaters at the ready, comfortably hanging on your belt.

MATERIAL Leather
COLOUR Black

9 PROFESSIONAL DJEMBE STRAP

The MEINL Djembe Strap comfortably and securely holds any djembe in the perfect playing position.

MATERIAL Cloth-covered nylon

FEATURES Quick change hook
Adjustable straps
Quick-release buckles
COLOUR Multi colour

10 SAMBA BELT

MEINL offers a high quality belt to ensure a safe and comfortable playing of several samba instruments.

MATERIAL Cotton
FEATURES Length adjustable
Adjustable shoulder padding
Strong attachment hooks
COLOUR R = Red

11 DRUM RUGS

The Meinl drum rugs come in four different unique designs.

SIZE 160 cm (5.25 ft) x 200 cm (6.5 ft)

DESIGNS **MDR-C1:** Original Camouflage
MDR-BK: Black
MDR-JB: Jawbreaker
MDR-ZB: Zebra

12 QUICK SET MARKERS

13 DRUMMER GLOVES

Meinl Drummer Gloves protect your hands from blisters and prevent the sticks from slipping, yet provide a natural feel.

SIZES M, L, XL
MATERIALS Breathable fabrics and leather
FEATURES Padded areas provide more durability
MDGFL: Finger-less Gloves
COLOUR Black



ADDITIONAL UPRIGHT ZIPPER

MCOB-11

MCOB-1134

MCOB-1212



MSTBB1



MBB



MTB



PROFESSIONAL MEINL BAGS

All Professional MEINL Bags are made from heavy duty nylon with reinforced stitching. They protect your instruments and assure hassle free transportation.

1 PROFESSIONAL CONGA BAGS

An extra top zipper simplifies packing and unpacking of your drum. Additional features are padded backpack straps and an external pocket for accessories.

SIZES 11", 11 3/4", 12 1/2"

FEATURES Additional upright zipper
External pocket
Padded backpack straps
Carrying grip

2 BONGO BAG

SIZE Bongos up to 7 1/2" Macho & 8 1/2" Hembra

FEATURE Carrying grip

3 PROFESSIONAL BONGO BAG

FEATURES Additional room for accessories
Padded shoulder strap
Carrying grip
Padded separator

4 PROFESSIONAL TIMBALES BAG

SIZES 14" & 15"

FEATURES External pocket for stand and cowbell
Padded shoulder strap
Carrying grip
Padded separator



DCAP-M DCAP-L DCAP-XL



MDJB-L MDJB-M MDJB-S



MDLXDJB-M MDLXDJB-L

SYNTHETIC FUR FOR EXTRA PROTECTION



MCHB

2 INTERNAL POCKETS WITH INNER VELCRO STRAPS

5 PROFESSIONAL DJEMBE CAPS

These caps protect your drum with a heavy duty reinforced top and an extra-long skirt with an elastic waist band.

SIZES M = 10"
L = 12"
XL = 13"

COLOUR Black

6 PROFESSIONAL DJEMBE BAGS

SIZES Small (up to 10")
Medium (up to 12")
Large (up to 13 1/2")

FEATURES External pocket
Carrying grip
MDJB-M, MDJB-L:
Padded backpack straps

7 DELUXE DJEMBE BAGS

SIZES Medium (up to 12")
Large (up to 13 1/2")

FEATURES Synthetic fur
External pocket
Padded backpack straps
Carrying grip

8 PROFESSIONAL CHIMES BAG

FEATURES Stores up to 2 chimes
Carrying grip
Inner Velcro straps
2 internal pockets



10" x 10"
MREB-10

12" x 12"
MREB-12



6"
MQW-6

8"
MQW-7

10"
MQW-10



12" x 18"
MREBB-12



12" x 4 1/2"
MCA-12

12" x 6"
MCA-12T

14" x 4"
MCA-14

EXTRA POCKET FOR SPARE HEADS

1 PROFESSIONAL REBOJO BAGS

SIZES 10" x 10"
12" x 12"

FEATURES Double-slide zipper
Shoulder strap
Carrying grip
External pocket

2 PROFESSIONAL CAIXA BAGS

SIZES 6", 8", 10"

FEATURES Padded shoulder strap
Carrying grip
External pocket

3 PROFESSIONAL REBOLO BAG

SIZE 12" x 18"

FEATURES Double-slide zipper
Padded shoulder strap
Carrying grip
External pocket

4 PROFESSIONAL CAIXA BAGS

SIZES 12" x 4 1/2"
12" x 6"
14" x 4"

FEATURES Double-slide zipper
Extra pocket for spare heads
Shoulder strap
Carrying grip
External pocket

5



14" x 28"
MTIMB-1428

14" x 35"
MTIMB-1435

6



14" x 28"
MTANB-14

7



16" x 20"
MSUB-16

18" x 22"
MSUB-18

20" x 24"
MSUB-20

22" x 24"
MSUB-22

5 PROFESSIONAL TIMBA BAGS

- SIZES** 14" x 28"
14" x 35"
- FEATURES** Double-slide zipper
Padded backpack straps
Carrying grip
External pocket

6 PROFESSIONAL TANTAM BAG

- SIZE** 14" x 28"
- FEATURES** Double-slide zipper
Padded backpack straps
Carrying grip
External pocket

7 PROFESSIONAL SURDO BAGS

- SIZES** 16" x 20"
18" x 22"
20" x 24"
22" x 24"
- FEATURES** Double-slide zipper
Padded backpack straps
Carrying grip
External pocket

1



MCJPC

2



MSTCJB

3



MCJB

4



MDLXCJB

5



MDLXCJB-L

SYNTHETIC FUR FOR
ADDITIONAL PROTECTION

6



MTREB



1 PROTECTION COVER FOR HEADLINER® CAJONS

This protection cover offers dependable protection at an affordable price, assuring your cajon will look as good as it sounds for a long time to come.

COLOUR Black

FEATURE Fits for all HCAJ1 and HCAJ2 models

2 STANDARD CAJON BAG

MEASURES 20 1/2" W x 12" H x 12" D

FEATURE Carrying grip

3 PROFESSIONAL CAJON BAG

MEASURES 20 1/2" W x 12" H x 12" D

FEATURES Padded shoulder strap
External pocket
Carrying grip

4 DELUXE CAJON BAG

The MEINL Deluxe Cajon Bag features an additional layer of synthetic fur, which removes surface moisture and provides extra protection. Additional features are a padded shoulder strap and an external pocket for accessories.

MEASURES 20 1/2" W x 12" H x 12" D

FEATURES Synthetic fur
Padded shoulder strap
External pocket
Carrying grip

5 DELUXE BASS PEDAL CAJON BAG

The MEINL Deluxe Cajon Bag is perfectly suited for the bigger sized Bass Pedal Cajon.

MEASURES 21 1/2" W x 17" H x 14 1/2" D

FEATURES Synthetic fur
Padded shoulder strap
External pocket
Carrying grip

6 TREJON/MARIMBULA BAG

MEASURES 21" W x 20" H x 18" D

FEATURES Extra padding for security
External pockets for small percussion
Padded backpack straps



16" x 2 1/2"
MFDB-16

18" x 2 1/2"
MFDB-18

20" x 2 1/2"
MFDB-20

22" x 2 1/2"
MFDB-22



8 1/2" x 2 1/2"
MFDB-7KA



6"
MTAB-06

PERFECT FIT



12" x 4"
MFDB-12BE

14" x 4"
MFDB-14BE



14" x 6"
MFDB-14IBO

18" x 4"
MFDB-18BO

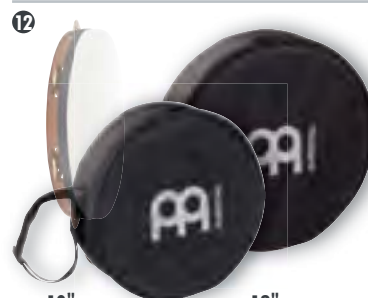

10"
MPAB-10

12"
MPAB-12

ALSO FITS FOR OUR
10" TAMBOURINES



10"
MSTTB

NEW!

7 PROFESSIONAL FRAME DRUM BAGS

- SIZES** 16", 18", 20", 22"
2 1/2" deep
FEATURES Double-slide zipper
Shoulder strap, Carrying grip

8 KANJIRA BAG

- SIZE** 8 1/2" x 2 1/2"
FEATURES Double-slide zipper
Shoulder strap
External pocket

9 PROFESSIONAL TAMBORIM BAG

- SIZE** 6"
FEATURES Double-slide zipper
Shoulder strap
External pocket

10 PROFESSIONAL DEEP SHELL FRAME DRUM BAGS

- SIZES** 12", 14", 18"
4" deep
FEATURES Double-slide zipper
Shoulder strap
Carrying grip

11 BODHRAN BAGS

- SIZES** 14" x 6"
18" x 4"
FEATURES Double-slide zipper
Shoulder strap
External pocket

12 PROFESSIONAL PANDEIRO BAGS

- SIZES** 10", 12"
FEATURES Double-slide zipper
Shoulder strap
External pocket

13 STANDARD TAMBOURINE BAG

- SIZE** 10"
FEATURES Sturdy zipper
Carrying grip



MDAB



MDOB



MDDGB



MDDGB-PRO



MIB-S



MIB-M



Black MSB-1

Original Camo MSB-1-C1

Jawbreaker MSB-1-JB



MDLXSB



EXTERNAL POCKETS



SPACIOUS STICK COMPARTMENT FOR QUICK ACCESS

1 PROFESSIONAL DARBUKA BAG

- FEATURES** Double-slide zipper
Additional upright zipper
Padded shoulder strap
Carrying grip
External pocket

2 PROFESSIONAL DOUMBЕК BAG

- FEATURES** Double-slide zipper
Additional upright zipper
Padded shoulder strap
Carrying grip
External pocket

3 STRAIGHT DIDGERIDOO BAG

- SIZE** 53"
FEATURES Padded shoulder strap
External pocket

4 PRO DIDGERIDOO BAG

- SIZE** 58"
FEATURES Padded shoulder strap
External pocket

5 PROFESSIONAL IBO BAGS

- SIZES** Small (9 3/4" W x 13 1/3" H x 9 3/4" D)
Medium (11" W x 14 1/2" H x 11" D)
INCLUDES Padded shoulder strap
Carrying grip
External pocket

6 PROFESSIONAL STICK BAGS

- FEATURES** External pockets
Shoulder straps
Extension straps
COLOURS Black
Jawbreaker
Original Camouflage

7 DELUXE STICK BAG

- MATERIAL** Padded synthetic leather
FEATURES External pockets
Shoulder straps
Elastic cord attachments
COLOUR Black



**Black
MSTCB22**



**Black
MCB22**

**Original Camo
MCB22-C1**

**Jawbreaker
MCB22-JB**



**Black
MCB22/MSB**

CYMBALS AND STICKS ARE ALWAYS READY AT HAND



**Original Camo
MCB22/MSB-C1**



**Black
MCB22-BP**

8 STANDARD CYMBAL BAG

The MEINL Standard Cymbal Bag holds cymbals up to 22" in diameter. It is produced in a high quality standard at an affordable price.

SIZE 22"

FEATURES Shoulder strap
Carrying grip

COLOUR Black

9 PROFESSIONAL CYMBAL BAGS

The Meinl 22" Professional Cymbal Bags are available in 3 different finishes. They have a small external pocket for other Drum Gear and an external hihat / splash compartment designed to hold cymbals up to 15" in diameter.

SIZE 22"

FEATURES Padded dividers
Padded shoulder strap

COLOURS Black
Jawbreaker
Original Camouflage

10 COMBO BAGS

An exceptional combination of a Meinl 22" Cymbal Bag and a Meinl Stick Bag. They come together from a zipper on the backside. Cymbals and sticks are always ready at hand.

SIZE 22"

FEATURES External compartment
Padded dividing pads
Padded shoulder strap
Carrying grip

COLOURS Black
Original Camouflage

11 PROFESSIONAL CYMBAL BACKPACK

The 22" Cymbal Bag has two backpack straps on the backside for easy transportation. External hihat / splash compartment which holds cymbals up to 15" in diameter, includes a glow-in-the-dark Meinl logo for spotting your bag in darkly lit venues.

SIZE 22"

FEATURES External hihat / splash compartment
Glow-in-the-dark Meinl logo
Two backpack straps on the backside

COLOUR Black



Support your favourite percussion brand with the official MEINL swag. A selection of exclusive items made from the highest quality materials.

1 T-SHIRT
SIZES S, M, L, XL, XXL
COLOUR Black
FRONT MEINL logo, small
BACK MEINL logo, big

2 T-SHIRT (MADE BY PUMA)
SIZES S, M, L, XL, XXL
COLOUR Black
FRONT Embroidered small MEINL logo and PUMA logo

3 FACES OF PERCUSSION SHIRT
SIZES S, M, L, XL, XXL
COLOUR White
FRONT Faces of Percussion

4 DRUM CIRCLE SHIRT
SIZES S, M, L, XL, XXL
COLOUR Pistachio
FRONT Drum Circle motif

5 SKULL T-SHIRT
SIZES S, M, L, XL, XXL
COLOUR Black
FRONT Skull

6 SKULL LONG SLEEVE
SIZES S, M, L, XL
COLOUR Black
FRONT Skull

7 POLO SHIRT
SIZES S, M, L, XL, XXL
COLOUR Black
FRONT MEINL logo, small

8 POLO SHIRT (MADE BY PUMA)
SIZES S, M, L, XL, XXL
COLOUR Black
FRONT Embroidered small MEINL logo and PUMA logo

10



Hood shirt
w/ zipper
M48

BACK

11

NEW!



Hood shirt
M48P

12

NEW!



Training jacket
M71P

13



Training jacket
M73

BACK

14



Bar stool, 24"
MBS24

Bar stool, 30"
MBS30

15

NEW!



Jawbreaker Sling Bags
M-BAG-BK-JB

Jawbreaker Sling Bags
M-BAG-JB

16

NEW!



Mouse Pad
M59

9 ARMY CAPS

COLOURS Black
Khaki

10 HOOD SHIRT W/ ZIPPER

SIZES S, M, L, XL, XXL
COLOUR Black
FRONT MEINL logo, small
BACK MEINL logo, big

11 HOOD SHIRT (MADE BY PUMA)

SIZES S, M, L, XL, XXL
COLOUR Black
FRONT Embroidered small MEINL logo
and PUMA logo

12 TRAINING JACKET (MADE BY PUMA)

SIZES S, M, L, XL, XXL
COLOUR Black
FRONT Embroidered small MEINL logo
and PUMA logo

13 TRAINING JACKET

SIZES M, L, XL, XXL
COLOUR Black
FRONT MEINL logo, small
BACK MEINL logo, big

14 BAR STOOL

SIZES 24", 30"

15 JAWBREAKER SLING BAGS

COLOURS **M-BAG-BK-JB**: Black
M-BAG-JB: Red

16 MOUSE PAD

JOIN OUR SOCIAL NETWORK

Unlike most companies we are not just about the business. We are focused on you... the players... those who making music with our instruments. With all the new social networks this has become much easier. We invite you to send us ideas, or just to say what like or don't like. You can find us on facebook, myspace, and twitter.

P.S. For the latest info about our artist, news and blog be sure to check out meinlpercussion.com

meinlpercussion.com



PERCUSSION
see the whole range



ION
ge

DEALERS
where to buy

VIDEOS
get inspired



facebook.com/meinlpercussionfanpage

twitter.com/meinlpercussion

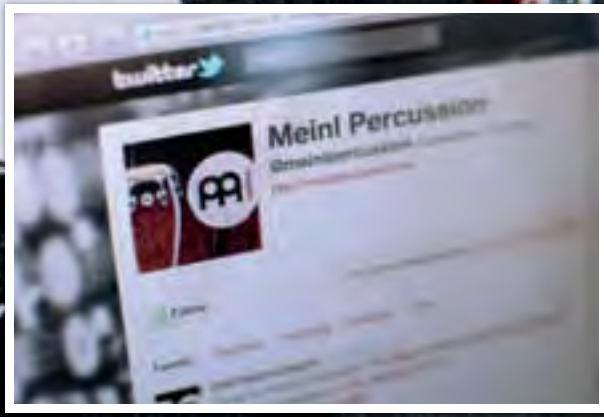

youtube.com/meinlpercussion



myspace.com/meinlpercussion

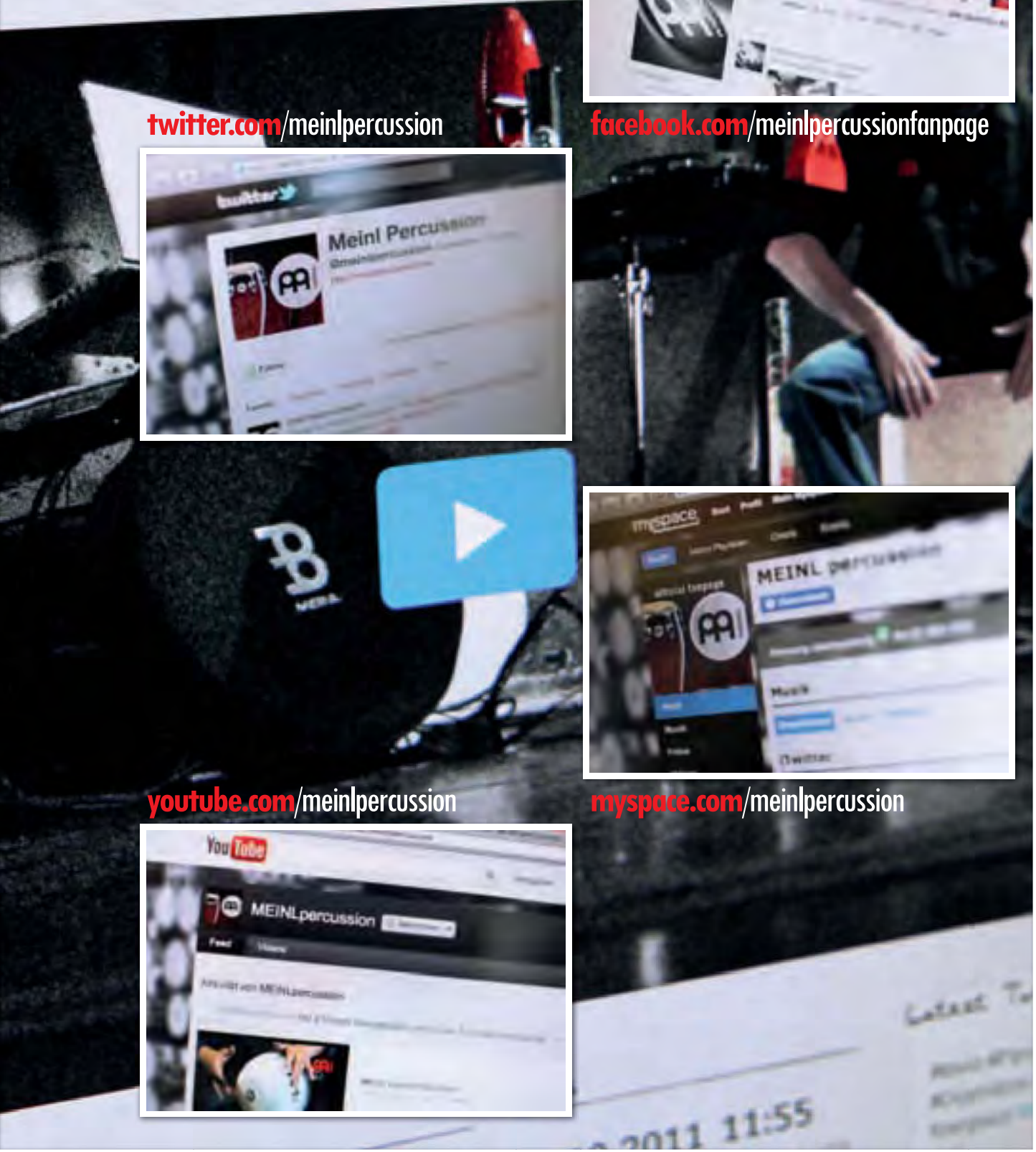

SPARE PARTS												
Model No.	Size	Height	Material	Features	Head	Rim	Lug	Bracket	Page			
CONGAS			Rubber Wood	Premium Fiberglass	American White Ash	True Skin Buffalo Heads	SSR-Rim	TTR-Rim	Conga Saver	Floatune Tuning System		
HEADLINER® SERIES WOOD CONGA SETS												
HC512 (incl. basket stands)	11" + 12"	28"	X		X			HHEAD11/HHEAD12C	HRIM11/HRIM12C	HCLUG	HCBRACKET-02	012/013
HC555 (incl. basket stands)	10" + 11"	28"	X		X			HHEAD10/HHEAD11	HRIM10/HRIM11	HCLUG	HCBRACKET-02	010/011
HEADLINER® DESIGNER SERIES CONGAS												
HC10 (incl. basket stands)	10"	28"	X		X			HHEAD10	HRIM10	HCLUG	HCBRACKET-02	014
HC11 (incl. basket stands)	11"	28"	X		X			HHEAD11	HRIM11	HCLUG	HCBRACKET-02	014
HC12 (incl. basket stands)	12"	28"	X		X			HHEAD12C	HRIM12C	HCLUG	HCBRACKET-02	014
HEADLINER® TRADITIONAL DESIGNER SERIES CONGAS												
HTC10 (incl. basket stands)	10"	28"	X			X		HHEAD10T	HRIM10T	HCLUG	HCBRACKET-02	015
HTC11 (incl. basket stands)	11"	28"	X			X		HHEAD11T	HRIM11T	HCLUG	HCBRACKET-02	015
HTC12 (incl. basket stands)	12"	28"	X			X		HHEAD12T	HRIM12T	HCLUG	HCBRACKET-02	015
HEADLINER® FIBERGLASS SERIES CONGAS												
HFC10 (incl. basket stands)	10"	28"	X		X			HHEAD10	HRIM10	HCLUG	HCBRACKET-02	018
HFC11 (incl. basket stands)	11"	28"	X		X			HHEAD11	HRIM11	HCLUG	HCBRACKET-02	018
HFC12 (incl. basket stands)	12"	28"	X		X			HHEAD12C	HRIM12C	HCLUG	HCBRACKET-02	018
ARTIST SERIES, LUIS CONTE												
LC11	11"	30"	X		X	X	X	TS-B-52	TTR-28	LUG-03	BRACKET-20	018
LC1134	11 3/4"	30"	X		X	X	X	TS-B-53	TTR-29	LUG-03	BRACKET-20	018
LC1212	11 1/2"	30"	X		X	X	X	TS-B-54	TTR-30	LUG-03	BRACKET-20	018
MARATHON® CLASSIC SERIES / DESIGNER SERIES												
MCC11	11"	30"	X		X	X	X	TS-B-38	SSR-25	LUG-03	BRACKET-15	019-021
MCC1134	11 3/4"	30"	X		X	X	X	TS-B-39	SSR-26	LUG-03	BRACKET-15	019-021
MCC1212	12 1/2"	30"	X		X	X	X	TS-B-40	SSR-27	LUG-03	BRACKET-15	019-021
PROFESSIONAL SERIES												
MP11	11"	30"	X		X	X	X	TS-B-34	SSR-22	LUG-01	BRACKET-14	022/023
MP1134	11 3/4"	30"	X		X	X	X	TS-B-35	SSR-23	LUG-01	BRACKET-14	022/023
MP1212	12 1/2"	30"	X		X	X	X	TS-B-36	SSR-24	LUG-01	BRACKET-14	022/023
FIBERCRAFT SERIES / DESIGNER SERIES												
FC11	11"	30"	X		X	X	X	TS-B-34	SSR-22	LUG-01	BRACKET-14	024/025
FC1134	11 3/4"	30"	X		X	X	X	TS-B-35	SSR-23	LUG-01	BRACKET-14	024/025
FC1212	12 1/2"	30"	X		X	X	X	TS-B-36	SSR-24	LUG-01	BRACKET-14	024/025
FLOATUNE SERIES												
FL10	10"	30"	X		X	X	X	TS-B-01	SSR-06	LUG-01		026
FL11	11"	30"	X		X	X	X	TS-B-03	SSR-07	LUG-01		026
FL12	12"	30"	X		X	X	X	TS-B-15	SSR-12	LUG-01		026
FL13	13"	30"	X		X	X	X	TS-B-21	SSR-15	LUG-01		026
ARTIST SERIES, MONGO SANTAMARIA												
MSA11	11"	30"			X	X	X	TS-B-07	SSR-08	LUG-02	BRACKET-16	026
MSA1134	11 3/4"	30"			X	X	X	TS-B-11	SSR-10	LUG-02	BRACKET-16	026
MSA1212	12 1/2"	30"			X	X	X	TS-B-17	SSR-13	LUG-02	BRACKET-16	026
WOODCRAFT SERIES												
WC11	11"	30"			X	X	X	TS-B-44	TTR-23	LUG-01	BRACKET-14	027
WC1134	11 3/4"	30"			X	X	X	TS-B-45	TTR-24	LUG-01	BRACKET-14	027
WC1212	12 1/2"	30"			X	X	X	TS-B-46	TTR-25	LUG-01	BRACKET-14	027
SPARE PARTS FOR STANDS												
10" Basket for HC555								HSTAND10				010/011
10" Basket for Designer/Fiberglass Series								HSTAND10				014-018
11" Basket for HC555/HC512 and Designer/Fiberglass Series								HSTAND11				010-018
12" Basket for HC512 and Designer/Fiberglass Series								HSTAND12				012-018
Rubber Feet (set of 3 pcs.) for Steely-II Stand								STAND-35				148
Rubber Tops (set of 3 pcs.) for Steely-II Stand								STAND-21				148
Screw Set complete for Steely-II Stand, black								STAND-22				148
Screw Set complete for Steely-II Stand, chrome								STAND-23				148
Screw Set complete for Steely-II Stand, gold tone								STAND-24				148
Socket Screw (set of 2 pcs.) black								STAND-26				148
Socket Screw (set of 2 pcs.) chrome								STAND-27				148
Socket Screw (set of 2 pcs.) gold tone								STAND-28				148
OTHER PARTS												
Lug Oil								SPARE-09				
Conga Saver for 8 mm Lugs (set of 6 pcs.)								CONGA-SAVER8				
Conga Saver for 10 mm Lugs (set of 6 pcs.)								CONGA-SAVER10				
Tuning Key, 13 mm + 14 mm, L shaped, gold tone								KEY-01				
Tuning Key, 13 mm + 14 mm, L shaped, chrome								KEY-02				



Model No.	Size	Material	Features	SPARE PARTS					Page	
				Head	Rim	Lug	Bracket			
BONGOS										
HEADLINER® SERIES ABS BONGO / ACRYLIC BONGO										
HB50	6 1/2"	X X					HHEAD6,5	RIM-NI3-65-BK	LUG-NINO3	032/033
HB50	7 1/2"	X X					HHEAD7,5	RIM-NI3-75-BK	LUG-NINO3	032/033
HEADLINER® SERIES WOOD BONGOS / DESIGNER / FIBERGLASS SERIES / TRADITIONAL										
HB100	6 3/4"		X				HHEAD634W	HRIM634W	HBLUG	032/033
HB100	8"		X				HHEAD8W	HRIM8W	HBLUG	032/033
HFB100	6 3/4"			X			HHEAD634W	HRIM634W	HBLUG	033
HFB100	8"			X			HHEAD8W	HRIM8W	HBLUG	033
HTB100	6 3/4"		X				HHEAD634T	HBRIM634T	HBLUG	033
HTB100	8"		X				HHEAD8T	HBRIM8T	HBLUG	033
FREE RIDE SERIES FWB190 WOOD BONGOS / DESIGNER SERIES										
FWB190	6 3/4"		X		X	X	HEAD-38	SSR-18	LUG-22	034
FWB190	8"		X		X	X	HEAD-39	SSR-19	LUG-22	034
FREE RIDE SERIES MINI WOOD BONGOS										
FWB100	3 1/2"		X	X	X	X	TS-B-31	SSR-16	LUG-19	035
FWB100	4 1/4"		X	X	X	X	TS-B-32	SSR-17	LUG-19	035
FREE RIDE SERIES FWB200 WOOD BONGOS										
FWB200	6 3/4"		X		X	X	HEAD-38	SSR-20	LUG-22	035
FWB200	8"		X		X	X	HEAD-39	SSR-21	LUG-22	035
LUIS CONTE ARTIST SERIES WOOD BONGO										
LC300	6 3/4"		X	X		X	TS-C-13	TTR-31	LUG-22	035
LC300	8"		X	X		X	TS-C-14	TTR-32	LUG-22	035
FREE RIDE SERIES FFB200 FIBERGLASS BONGOS										
FFB200	6 3/4"		X		X	X	TS-B-50	SSR-34	LUG-23	037
FFB200	8"		X		X	X	TS-B-51	SSR-35	LUG-23	037
FREE RIDE SERIES FFB400 FIBERGLASS BONGOS / DESIGNER SERIES										
FFB400	7"		X	X	X	X	TS-C-02	SSR-02	LUG-07	037
FFB400	8 1/2"		X	X	X	X	TS-C-03	SSR-04	LUG-07	037
FREE RIDE SERIES FWB400 WOOD BONGO										
FWB400	7"		X	X	X	X	TS-C-02	SSR-02	LUG-07	038
FWB400	8 1/2"		X	X	X	X	TS-C-03	SSR-04	LUG-07	038
FREE RIDE SERIES COLLECTION WOOD BONGO										
CS400	7"		X	X	X	X	TS-C-02	SSR-02	LUG-07	039
CS400	8 1/2"		X	X	X	X	TS-C-03	SSR-04	LUG-07	039
FREE RIDE SERIES WOODCRAFT BONGO										
WB500	7"		X	X		X	TS-C-11	TTR-26	LUG-07	039
WB500	9"		X	X		X	TS-C-12	TTR-27	LUG-07	039
SPARE PARTS FOR STANDS										
Memory Clamp, chrome, for middle stand tube for TMB + TMB-S				STAND-07					149	
Memory Clamp, chrome, for lower stand tube for TMB + TMB-S				STAND-09					149	
Memory Clamp, chrome, for upper stand tube for TMB				STAND-11					149	
Fast Lock Set, chrome for TMB + TMB-S				STAND-14					149	
Rubber Feet (set of 3 pcs.) for all Bongo Stands				STAND-16					149	
L-Shaped Clamp for top part for TMB + TMB-S				STAND-18					149	
Upper Stand Section, complete for TMB				STAND-34					149	
OTHER PARTS										
Lug Oil				SPARE-09						
Tuning Key, 13 mm + 14 mm, L-shaped, chrome				KEY-02						

Model No.	Size	Material	Features	SPARE PARTS					Page		
				Head	Rim	Lug	Bracket				
DANCING PERCUSSION											
FIBERGLASS FAMILY DRUMS											
HFDD2	8"		X				HHEADHFDD	HRIMHFDD2	HFDDLUG	HDBRACKET-03	049
FIBERGLASS DANCING CONGA											
HC301	8 1/2"		X				HHEAD8,5	HRIM8,5	HDCLUG	HDBRACKET-02	049
FIBERGLASS DANCING DJEMBE											
HDJ400	12"		X				HHEAD12	HRIM12	HDLUG	HDBRACKET-02	049
FIBERGLASS MINI DANCING DJEMBES											
HDJ200	8"		X				HHEADJ8	HRIMJ8	HD200LUG		049

Model No.	Size	Height	Material	Features	SPARE PARTS				Page	
					Head	Rim	Lug	Bracket		
HEADLINER® SERIES ROPE TUNED WOOD DJEMBES NILE SERIES										
HDJ4-S	8"	15 3/4"	X		X	HEAD-61			042	
HDJ4-M	10"	20"	X		X	HEAD-53			042	
HDJ4-L	12"	24"	X		X	HEAD-54			042	
HDJ4-XL	13"	25"	X		X	HEAD-55			042	
HEADLINER® SERIES ROPE TUNED WOOD DJEMBES BLACK RIVER SERIES										
HDJ3-S	8"	15 3/4"	X		X	HEAD-61			042	
HDJ3-M	10"	20"	X		X	HEAD-53			042	
HDJ3-L	12"	24"	X		X	HEAD-54			042	
HDJ3-XL	13"	25"	X		X	HEAD-55			042	
HEADLINER® SERIES ROPE TUNED WOOD DJEMBES CONGO SERIES										
HDJ1-M	10"	20"	X		X	HEAD-53			043	
HDJ1-L	12"	24"	X		X	HEAD-54			043	
HDJ1-XL	13"	25"	X		X	HEAD-55			043	
HEADLINER® SERIES ROPE TUNED WOOD DJEMBES TRIBAL SERIES										
HDJ2-M	10"	20"	X		X	HEAD-53			043	
HDJ2-L	12"	24"	X		X	HEAD-54			043	
HDJ2-XL	13"	25"	X		X	HEAD-55			043	
ORIGINAL AFRICAN STYLE ROPE TUNED WOOD DJEMBE WATER RHYTHM SERIES										
ADJ2-M+BAG	10"	20"	X		X	HEAD-53			044	
ADJ2-L+BAG	12"	24"	X		X	HEAD-54			044	
ADJ2-XL+BAG	13"	25"	X		X	HEAD-55			044	
ORIGINAL AFRICAN STYLE ROPE TUNED WOOD DJEMBE EARTH RHYTHM SERIES										
ADJ3-M+BAG	10"	20"	X		X	HEAD-53			045	
ADJ3-L+BAG	12"	24"	X		X	HEAD-54			045	
ADJ3-XL+BAG	13"	25"	X		X	HEAD-55			045	
ORIGINAL AFRICAN STYLE ROPE TUNED WOOD DJEMBE MOON RHYTHM SERIES										
ADJ4-M+BAG	10"	20"	X		X	HEAD-53			045	
ADJ4-L+BAG	12"	24"	X		X	HEAD-54			045	
ADJ4-XL+BAG	13"	25"	X		X	HEAD-55			045	
PROFESSIONAL AFRICAN STYLE DJEMBES / DELUXE AFRICAN STYLE DJEMBES										
PROADJ1	12"	24"	X		X	HEAD-54			046	
PROADJ2	12"	24"	X		X	HEAD-54			046	
PROADJ3	14"	26"	X		X	HEAD-56			047	
PROADJ4	12"	24"	X		X	HEAD-54			046	
AFRICAN BOUGARABOU										
ABGB-L	12"	24"	X		X	HEAD-63			046	
JOURNEY SERIES ROPE TUNED FIBERGLASS DJEMBES										
FADJ1-M	10"	18"		X	X	HEAD-70			048	
FADJ1-L	12"	24"		X	X	HEAD-71			048	
FADJ2-M	10"	18"		X	X	HEAD-70			048	
FADJ2-L	12"	24"		X	X	HEAD-71			048	
HEADLINER® SERIES WOOD DJEMBES / DESIGNER SERIES DJEMBE										
HDJ500	12 1/2"	25 1/4"	X			HHEAD12,5W	HRIM12,5W	HDLUGW	HDBRACKET-02	051
HDJ600	12"	23 1/2"	X			HHEAD12W	HRIM12W	HDLUGW	HDBRACKET-02	051
ROPE TUNED WOOD DJEMBES										
DJWR3	12"	24 1/4"	X		X	TS-CA-01			051	
FLOATUNE SERIES 12 3/4" WOOD DJEMBES										
DJW2	12 3/4"	25 1/4"	X		X	TS-G-02	SSR-30	LUG-04	052	
FLOATUNE SERIES 12" WOOD DJEMBES										
DJW3	12"	24 1/4"	X	X	X	TS-G-01	SSR-29	LUG-04	052/053	
FLOATUNE SERIES FIBERGLASS DJEMBES										
DJF3	12"	24 1/4"		X	X	TS-G-01	SSR-29	LUG-05	053	
SPARE PARTS FOR STANDS										
Rubber Feet (set of 3 pcs.) for Steely-II Stand						STAND-35		150		
Rubber Tops (set of 3 pcs.) for Steely-II Stand						STAND-21		150		
Socket Screw (set of 2 pcs.) chrome						STAND-27		150		
Fast Lock Set, chrome						STAND-14		150		
Rubber Feet (set of 3 pcs.) for Djembe Stand						STAND-16		150		
OTHER PARTS										
Lug Oil						SPARE-09				
Tuning Key, 13 mm + 14 mm, L-shaped, chrome						KEY-02				

Model No.	Size	Material	Features	SPARE PARTS				Page	
				Head	Rim	Lug	Bracket		
DARBUKAS & DOUMBEKS									
		Aluminum							
		Copper							
		Rubber Wood							
		Premium Fiberglass							
		Synthetic Heads							
		Hand selected buffalo heads							
		Natural rawhide							
		True Skin Buffalo Heads							
		TTR-Rim							
		Hand hammered shell							
		Hand engraved shell							
ALUMINUM DARBUKAS									
HE-100	5 1/3"	X	X					HE-HEAD-100	056
HE-101	5 7/8"	X	X					HE-HEAD-101	056
HE-102	6 1/2"	X	X					HE-HEAD-102	056
HE-103	7 1/4"	X	X					HE-HEAD-103	056
HE-104	8"	X	X					HE-HEAD-104	056
HE-113	7 1/4"	X	X			X		HE-HEAD-103	057
HE-114	8"	X	X			X		HE-HEAD-104	057
HE-122	6 1/2"	X	X				X	HE-HEAD-102	056
HE-124	8"	X	X				X	HE-HEAD-104	056
ALUMINUM JINGLE DARBUKAS									
HE-314	8"	X	X			X		HE-HEAD-104	057
HE-315	8 1/4"	X	X			X		HE-HEAD-315	057
COPPER DARBUKAS									
HE-214	7 1/2"	X	X			X		HE-HEAD-214	057
HE-215	7 7/8"	X	X			X		HE-HEAD-215	057
HE-204	7 1/2"	X	X		X		X	HE-HEAD-204	057
HE-205	7 7/8"	X	X		X		X	HE-HEAD-205	057
FIBERGLASS DOUMBEK									
FDB3000G	8 1/2"		X X					HEAD-80	058
ALUMINUM DOUMBEKS									
HE-3000	8 1/2"	X	X					HE-HEAD-3000	058
HE-3018	8 1/2"	X	X				X	HE-HEAD-3000	059
HE-3020	8 1/2"	X	X					HE-HEAD-3000	058
HE-3030	8 1/2"	X	X				X	HE-HEAD-3000	059
HE-3400	8 1/2"	X	X					HE-HEAD-3400	059
COPPER DOUMBEK									
HE-3012	8 1/2"	X	X				X	HE-HEAD-3000	059
PROFESSIONAL DOUMBEK									
HE-5000	9"	X	X					HE-HEAD-5000	059

Model No.	Size	Material	Features	SPARE PARTS				Page				
				Head	Rim	Lug	Bracket					
RITUAL DRUMS												
		Aluminum										
		Copper										
		Rubber Wood										
		Premium Fiberglass										
		Synthetic Heads										
		Hand selected buffalo heads										
		Natural rawhide										
		True Skin Buffalo Heads										
		TTR-Rim										
		Hand hammered shell										
		Hand engraved shell										
BATAS												
BA1	5 1/4"		X X					HEAD-07	RIM-04	LUG-12		062
BA1	8"		X X				X	HEAD-08	RIM-05	LUG-12		062
BA2	5 3/4"		X X				X	HEAD-09	RIM-06	LUG-12		062
BA2	8 3/4"		X X				X	HEAD-10	RIM-07	LUG-12		062
BA3	6 3/4"		X X				X	HEAD-11	RIM-08	LUG-12		062
BA3	12"		X X				X	HEAD-12	RIM-09	LUG-12		062
TALKING DRUM												
TD7	7 1/2"		X X					HEAD-35	RIM-25			062
WOOD CONGUITAS												
HCG89	8"		X		X			HEAD-05	TTR-05	LUG-11	HDBRACKET-02	063
HCG89	9"		X		X			HEAD-06	TTR-08	LUG-11	HDBRACKET-02	063
TAMBORA												
MTA1	11"		X		X			TS-B-09 (NT)	RIM-03	LUG-10	BRACKET-06	063
MTA1	11"		X		X			TS-B-10 (WH)		LUG-10	BRACKET-06	063
OTHER PARTS												
BEATER (Rattan) for Talking Drum				SPARE-10				062				
BEATER (Mahogany Wood) for Talking Drum				SPARE-23				062				



Model No.	Size	Material				Features				SPARE PARTS				Page		
		German B8 cymbal bronze	Solid brass	Stainless steel	Black powder coated steel	Steel	Hammered shells	Two worked in flanges	Cuban style (bottom edge)	Special brackets cast	Floatune Tuning System	Head	Rim		Lug	Bracket
TIMBALES																
HEADLINER® SERIES																
HT1314, old version	13"					X	X					HEAD-24	RIM-37	LUG-26	BRACKET-18	
HT1314, old version	14"					X	X					HEAD-22	RIM-38	LUG-26	BRACKET-18	
HT1314, 2011 version	13"					X	X					HEAD-24	RIM-37	LUG-44	BRACKET-26	083
HT1314, 2011 version	14"					X	X					HEAD-22	RIM-38	LUG-44	BRACKET-26	083
MARATHON® SERIES																
MT1415CH + MT1415B	14"					X	X					HEAD-22	RIM-23	LUG-17	BRACKET-12	083
MT1415CH + MT1415B	15"					X	X					HEAD-23	RIM-24	LUG-17	BRACKET-12	083
MT1415BN	14"				X		X					HEAD-22	RIM-27	LUG-17	BRACKET-25	083
MT1415BN	15"				X		X					HEAD-23	RIM-28	LUG-17	BRACKET-25	083
MTT1415	14"				X		X					HEAD-22	RIM-27	LUG-17	BRACKET-25	084
MTT1415	15"				X		X					HEAD-23	RIM-28	LUG-17	BRACKET-25	084
ARTIST SERIES, AMADITO VALDÈS																
AV1BK	14"				X		X			X		HEAD-22	RIM-27	LUG-17		084
AV1BK	15"				X		X			X		HEAD-23	RIM-28	LUG-17		084
FLOATUNE SERIES																
TI1BK	13"				X		X			X		HEAD-24	RIM-21	LUG-17		084
TI1BK	14"				X		X			X		HEAD-22	RIM-22	LUG-17		084
ARTIST SERIES, LUIS CONTE																
LC1BRASS	14"		X	X			X	X	X	X		HEAD-22	RIM-19	LUG-16	BRACKET-08 brass	085
LC1BRASS	15"		X	X			X	X	X	X		HEAD-23	RIM-20	LUG-16	BRACKET-09 brass, small	085
LC1STS	14"		X	X			X	X	X	X		HEAD-22	RIM-19	LUG-16	BRACKET-10 chrome	085
LC1STS	15"		X	X			X	X	X	X		HEAD-23	RIM-20	LUG-16	BRACKET-11 chrome, small	085
PROFESSIONAL SERIES																
BT1415	14"	X					X	X	X			HEAD-22	RIM-19	LUG-16	BRACKET-10 chrome	085
BT1415	15"	X					X	X	X			HEAD-23	RIM-20	LUG-16	BRACKET-11 chrome, small	085
DRUMMER SNARE TIMBALES																
MDST8BK	8"				X	X						HEAD-41	RIM-29	LUG-21	BRACKET-13	088
MDST10BK	10"				X	X						HEAD-42	RIM-30	LUG-21	BRACKET-13	088
DRUMMER TIMBALE																
MDT13CH	13"				X							HEAD-43	RIM-31	LUG-21	BRACKET-13	088
MINI TIMBALES																
MIT810CH	8"				X							HEAD-41	RIM-29	LUG-21	BRACKET-13	088
MIT810CH	10"				X							HEAD-42	RIM-30	LUG-21	BRACKET-13	088
ARTIST SERIES, TAKU HIRANO, HAND-BALE																
MHT13	13"				X							HEAD-43	RIM-47	LUG-21	BRACKET-13	089
ARTIST SERIES, DAVE MACKINTOSH, ATTACK TIMBALE																
MDT88	8"				X							HEAD-41	RIM-48	LUG-21	BRACKET-13	089
SPARE PARTS FOR STANDS																
Timbale Stand, chrome												TMT				
Cowbell Holder, complete for MEINL Timbales												STAND-01				
Cowbell Holder, complete for HT1314 Timbales												HDSTAND-01				
Memory Clamp, chrome for middle stand tube												STAND-07				
Memory Clamp, black for middle stand tube												STAND-08				
Memory Clamp, chrome for lower stand tube												STAND-09				
Memory Clamp, black for lower stand tube												STAND-10				
Fast Lock Set, chrome												STAND-14				
Fast Lock Set, black												STAND-15				
Rubber Feet (set of 3 pcs.) for Timbales Stand												STAND-16				
OTHER PARTS																
Lug Oil												SPARE-09				
Tuning Key, 13 mm + 14 mm, L shaped, chrome												KEY-02				



Model No.	Size	Material								Features								SPARE PARTS				Page
		Hardwood	Aluminum	Premium Fiberglass	Rubber Wood	Poplar Wood	ABS	Steel	Counter sunk bolt heads	Replaceable synthetic heads	Replaceable goat heads	Replaceable nappa heads	Height adjustable legs	Steel snare wires	Floatune Tuning System	Head	Rim	Lug	Bracket			
SAMBA																						
																						
TRADITIONAL ALUMINUM & WOOD SURDOS																						
SU16	16"	X	X						X	X											092	
SU18	18"	X	X						X	X											092	
SU20	20"	X	X						X	X											092	
SU22	22"	X	X						X	X											092	
TRADITIONAL STAND ALONE ALUMINUM & WOOD SURDOS																						
SU16-L	16"	X	X						X	X		X									093	
SU18-L	18"	X	X						X	X		X									093	
SU20-L	20"	X	X						X	X		X									093	
SU22-L	22"	X	X						X	X		X									093	
BAHIA ALUMINUM SURDOS																						
SUB18	18"		X						X	X											096	
SUB20	20"		X						X	X											096	
SUB22	22"		X						X	X											096	
BAHIA WOOD SURDOS																						
SUB18AB-M	18"	X							X	X											096	
SUB20AB-M	20"	X							X	X											096	
SUB22AB-M	22"	X							X	X											096	
ALUMINUM CAIXAS																						
CA12	12"		X						X	X			X								097	
CA14	14"		X						X	X			X								097	
TRADITIONAL ALUMINUM CAIXA																						
CA12T	12"		X						X	X			X								097	
ALUMINUM REPINQUES																						
RE10	10"		X						X	X											097	
RE12	12"		X						X	X											097	
WOOD REPINIQUE																						
RE12AB-M	12"				X				X	X											097	
TIMBAS																						
TIM14	14"				X				X												098	
TANTAM																						
TAN14	14"				X					X											098	
REBOLO																						
REB12	12"				X					X											098	
ALUMINUM CUICAS																						
QW6	6"		X							X											099	
QW10	10"		X							X	X										099	
FIBERGLASS CUICA																						
QW7	8"		X							X			X								099	
TAMPEIRO																						
TP06AB-M	6"				X				X	X	X										101	
SILENT TAMBORIM																						
STBR06	6"				X																101	
FLOATUNE TAMBORIMS																						
TBR06	6"		X	X	X	X	X	X	X	X	X			X							101	
OTHER PARTS																						
A Go Go Bell Holder															STBAGH							
Tuning Key															KEY-08							
Tuning Key for Caixa															KEY-09							
Tuning Key for Surdo and Repinique															KEY-10							
Beater for Samba Triangle															SPARE-30							
Nappa Heads for Surdo															HEAD-66 = 16" / HEAD-67 = 18" / HEAD-68 = 20" / HEAD-69 = 22"						156	

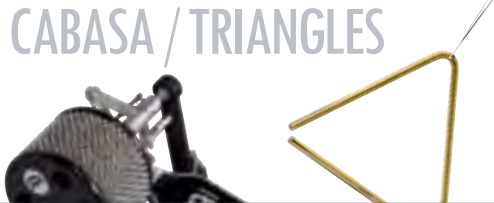

Model No.	Size	Material										Features				SPARE PARTS						
		Hardwood	Aluminum	Premium Fiberglass	Rubber Wood	ABS	Steel	Counter sunk bolt heads	Replaceable synthetic heads	Replaceable goat heads	Replaceable napa heads	Height adjustable legs	Steel snare wires	Floatune Tuning System	Head	Rim	Lug	Bracket	Page			
FRAME DRUMS																						
																						
PLENERA SET																						
PL-SET	8"					X							X					HEAD-75	RIM-51	LUG-43	BRACKET-24	108
PL-SET	10"					X							X					HEAD-76	RIM-52	LUG-43	BRACKET-24	108
PL-SET	12"					X							X					HEAD-77	RIM-53	LUG-43	BRACKET-24	108
PANDEIROS																						
PA10CN-M	10"				X			X	X									HEAD-44	RIM-33	LUG-24	BRACKET-19	109
PA10ABS-BK	10"					X	X	X										HEAD-48	RIM-33	LUG-24	BRACKET-19	109
PA10ABS-BK-NH	10"					X	X	X	X									HEAD-72	RIM-33	LUG-24	BRACKET-19	109
PA12CN-M	12"				X			X	X	X								HEAD-45	RIM-34	LUG-24	BRACKET-19	109
OTHER PARTS																						
Tuning Key for Pandeiro													KEY-08									
Tuning Key for Frame Drums													KEY-11									
Protection Caps for Plenera lugs													CAPS-04									

Model No.	SPARE PARTS		Page
	Name	Model No.	
FOOT CABASA / TRIANGLES			
			
FOOT CABASA			
FCA5-L	Coil springs	SPARE-20	081
FCA5-L	Regular spring	SPARE-26	081
TRIANGLES			
TRI10B	Beater	SPARE-31	129
TRI15B	Beater	SPARE-31	129
TRI20B	Beater	SPARE-31	129
JCTRI20	Beater	SPARE-31	129



DISCLAIMER

All features are subject to change without notice. Not responsible for typographic errors. No part of this book may be reprinted, reproduced, or included in any online service in any form in whole or in part, without the prior permission of MEINL.

© 2012 Roland Meinel Musikinstrumente GmbH & Co. KG

ADVERTISING CONCEPT & DESIGN BY:

Marcus Beloch, Matthias Mautner
Jennifer Pruden
www.ercasdieagentur.de

CONTENT & DIRECTION BY:

Udo Heubeck, Mario Schmitt

MEINL WOULD LIKE TO THANK:

Christian Habermeier, Sebastian Jäger
www.studio-waldeck.de
Sven Mihm
www.mihm-werbung.de

PHOTO CREDITS:

Aldo Antonietti
Alex Solca
Charlie Hunter
David Garfield
Dennis Boxem
Djeneba Aduayom
Doc Severinsen
F. Desmaele
Heinz Kronberger
Jimbo James
Karla Reinhardt
Klaus Mümpfer
Mario Schmitt
Nilaya Sabnis
Rick Malkin
Stephan Hänisch
Tatiane Moraes
Tina Guo
Vitaliy Sinkevich
Wong Sze Fei

MEINL GLOBAL HEADQUARTER

Am Bahnhof 2
91468 Gutenstetten
Germany

MEINL USA L.C.

3300 Ambrose Avenue
Nashville, TN 37207
USA

This catalogue has been printed on
FSC certificated paper

Printed in Germany M-CA501211



