

THE ULTIMATE SELECTION



**THE MEINL BOOK
OF PERCUSSION**

2013



THE ULTIMATE SELECTION
EXCLUSIVELY PRESENTED BY **MEINL**

2013



THE MEINL ARTIST FAMILY



Abdissa Mamba
Assefa, Finland



Alex Pertout, Australia



Alan Toreba, Brazil



Alejandro
Suarez, Argentina



Alex Thomas, UK

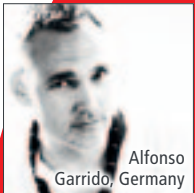

Alfonso
Garrido, Germany



Amadito Valdes, Cuba



Amel Serra,
Netherlands



Andrew
Lazaro, Puerto Rico



Anna
Tornquist, Sweden



Arnold
Riedhammer, Germany



Benny
Greb, Germany

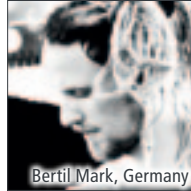

Bertil Mark, Germany



Bertram
Engel, Germany



Bram
Hakkens, Netherlands



Brian
Rosenworcel, USA

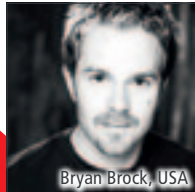

Bryan Brock, USA



Carlo Marzo, Italy



Carlos Maldonado, Puerto Rico



Cem Arnold
Süzer, Germany



Charly Boeck, Germany



Chester
Thompson, USA



Chris Coleman, USA



Christian
Einheller, Austria



Christian
Fehre, Germany



Cristian LaTorre, Chile



Christian
Lillinger, Austria



Chuck Prada, USA



Daniel
Svensson, Sweden



Dany Moreno, Spain



Dany
Schnyder, Switzerland



Dave Mackintosh, UK



Dirk
Verbeuren, Belgium



Dong Kexin, China



Ellen Mayer, Germany



Engin Guerkey, Turkey



Ephraim Salzmann, Switzerland



Felix Pollard, USA



Flo Dauner, Germany



Florian Alexandru-Zorn, Germany

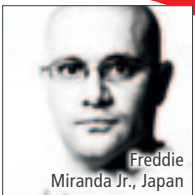

Freddie Miranda Jr., Japan



Georg Edlinger, Austria



Gilson Batista Silveira, Italy



Giovanni Imparato, Italy



Greg Bishop, UK



Guy Brogle, France



Holger Mertin, Germany



Hoomayon Nasiri, Iran



Humberto Leon Ibarra, USA



Hussein Abdala, USA



Igor Stimac, Croatia



Inor Sotolongo, France



Ismaila M'Baye, Italy



Jarrenthon de Leon, Dominican Republic



Javier Solis, USA



Villar Morales, Spain



Jean-Philippe Batailley, France



Jean Paul Gaster, USA



Jeroen de Rijk, Netherlands



Jimmy Branly, USA



Joannie Labelle, Canada



Joe Vasconcellos, Chile



Johnny Rabb, USA



Jorge Bermudez, USA



Jorge Pérez, Spain



Jose Cortijo, Germany

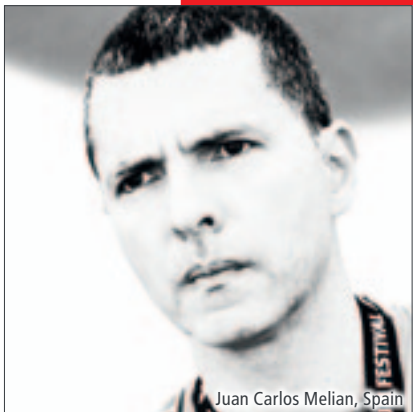

Juan Carlos Melian, Spain



Jost Nickel, Germany



Julio Figueroa, USA



Junior Moraes, Brazil



Kenny Aronoff, USA



THE MEINL ARTIST FAMILY



KJ Sawka, UK



Konrad Graf, Germany



Larry Salzman, USA



Justin Porées, USA



Jiro Yamaguchi, USA

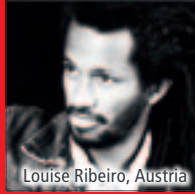

Louise Ribeiro, Austria



Luis Conte, USA



Luis Palacios, Cuba



Ludo Srnc, Slovakia



Marcie Chapa, USA



Marco Catinaccio, Italy



Mark Essien, Germany



Matthias Meusel, Germany



Marcio Peeter, USA



Max Klaas, Germany



Miguel Fenton, Canada



Mike Johnston, USA



Miloš Vacik, Czech Republic



Monojit Dutta, India



Murdoch MacDonald, UK



Muthu Kumar, India



Nick D'Virgilio, USA



Noby Lehmann, Switzerland



Norman Bonink, Netherlands



Oliver Gatringer, Austria



Nebojsa Jovan Zivkovic, Germany



Onkel, Germany



Pablo Cepeda, Sweden



Paolo Cimmino, Italy



Paul Martinez, Spain



Paul Walsham, UK



Peppe Sannino, Italy



Prince Akongo, Togo



Ralf Gustke, Germany



Ramesh Shotham, Germany



Raúl Maldonado, Puerto Rico



Raúl Oviedo, Mexico



Riaan VanRensburg, South Africa



Rigo Collazo, Puerto Rico



Roland Peil, Germany



Robbie Harris, Ireland



Roberto Santamaria, Cuba



Rodney Holmes, USA



Roel Calister, Netherlands



Ron van Stratum, Netherlands



Ruediger Maul, Germany



Stephan Maass, Germany



Russ Miller, USA



Sabine Vieten, Germany



Shyam Edwankar, India



Simon Mullumby, Australia



Suat Borazan, Turkey



Stef Broks, Netherlands



Taku Hirano, USA



Stuart Pringle, UK



Tamba Gwindi, Trinidad and Tobago



Tarcisio Molinaro, Italy



Thomas Eby, Sweden



Thomas Lang, Austria

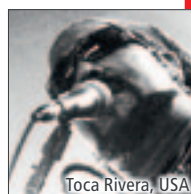

Toca Rivera, USA



Tommy Cluefetos, USA



Trevor Lawrence Jr., USA



Wolfgang Haffner, Germany



Yoel Paez, Spain



Yogi Jockusch, Germany



Yuisney Aguilar, Spain



Zhang Hongchun, China



WHAT'S NEW IN 2013

MORE THAN 130 NEW ITEMS

MEINL Percussion is proud to be the leading developer of percussion instruments. We work hard to stimulate the market and broaden musical horizons with our ultimate selection.

Here is an over-view of what's new in our line-up for 2013.

We have more than 130 new items, something in almost every category and price range.

NEW!

025



MARATHON® CLASSIC SERIES CONGA SET

NEW!

045



RAPC (RADIAL PLY CONSTRUCTION) BONGOS

NEW!

053

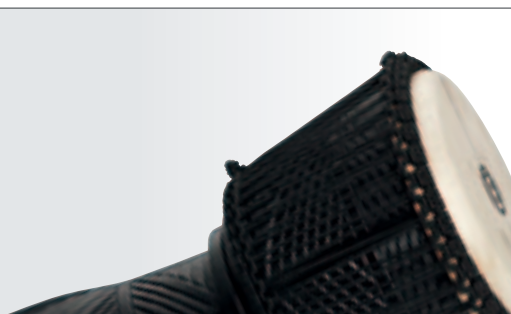

DJEMBEFOLAS

NEW!

069



ARTISAN EDITION DOUMBEEKS

NEW!

086



ARTISAN EDITION FLAMENCO CAJONS

NEW!

089



MARIMBULA

NEW!

090



MAKE YOUR OWN CAJON

NEW!

093



CAJON ADD-ONS

NEW!

097



MARATHON® SERIES TIMBALES

INDEX

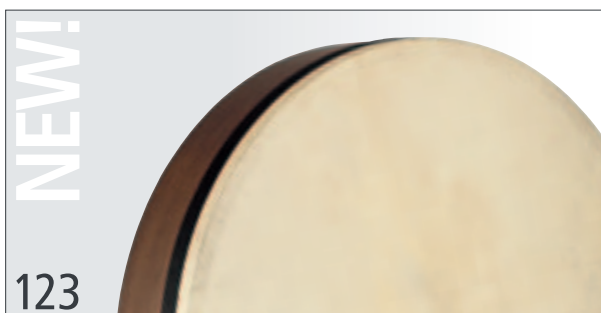

NEW!

123

ARTISAN EDITION TARS & MIZHARS

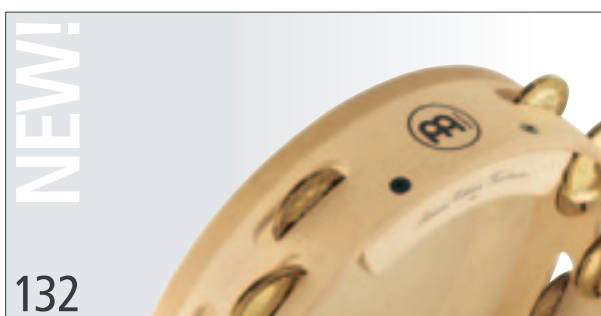

NEW!

132

HEADED ARTISAN EDITION TAMBOURINES



NEW!

144

TURBO CRASHER



NEW!

161

ARTIST SERIES DIDGERIDOO

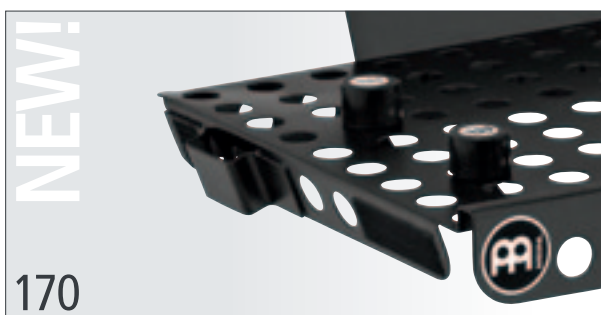

NEW!

170

LAPTOP TABLE STAND

A-Go-Go's	114	Kalimbas	149
Bags	174	Kanjira	121
Batas	072	Maracas	156
Bendirs	120	Marimbula	089
Berimbau	072	Merchandise	182
Blocks	143/148	Metal Effects	144
Bodhrans	121	Mizhars	119/123
Bongo Cajons	089	Palito	089
Bongos	038	Pandeiros	125
Bougarabou	052	Rainmakers	158
Cabasas	148	Ramwong	073
Caixas	111	Rebolo	112
Cajita	089	Repiniques	111
Cajons	078	Ritual Drums	072
Cajon Add-Ons	093	Rocars	113
Cajons – Make Your Own	090	Samba/Brazilian	108
Candela Percussion Cymbals	162	See Drums	124
Castanets	149	Shakers	114/152/157
Chimes	146	Shekeres	073
Claves	150	Slap-Top Cajon	088
Congas	018	Sleigh Bells	148
Conguitas	073	Sound Effects	151
Cowbells	140	Stands	166
Cuicas	113	Sticks/Beaters	164
Dafs	121	Subwoofer Cajon	088
Dancing Percussion	059	Surdos	108
Darbukas	064	Tablas	070
Didgeridoos	159	Tables	170
DjembeFolas	053	Talking Drums	072
Djembes	048	Tambora	073
Doumbeks	066	Tambourines	128
Foot Percussion	092	Tampeiro/Tamborims	115
Frame Drums	118	Tantam	112
Güiras/Güiros	148/157	Tars	118/123
Hand-Bale	103	Timbales	096
Hand Drums	124	Timbales – Drummer	102
Hand Percussion	148/157	Timbas	112
Hardware	172	Travel Cajon	094
Ibo Drums	074	Trejon	088
Jingle Sticks	139	Triangles	145

AND MANY MORE...



HOW WE MAKE IT

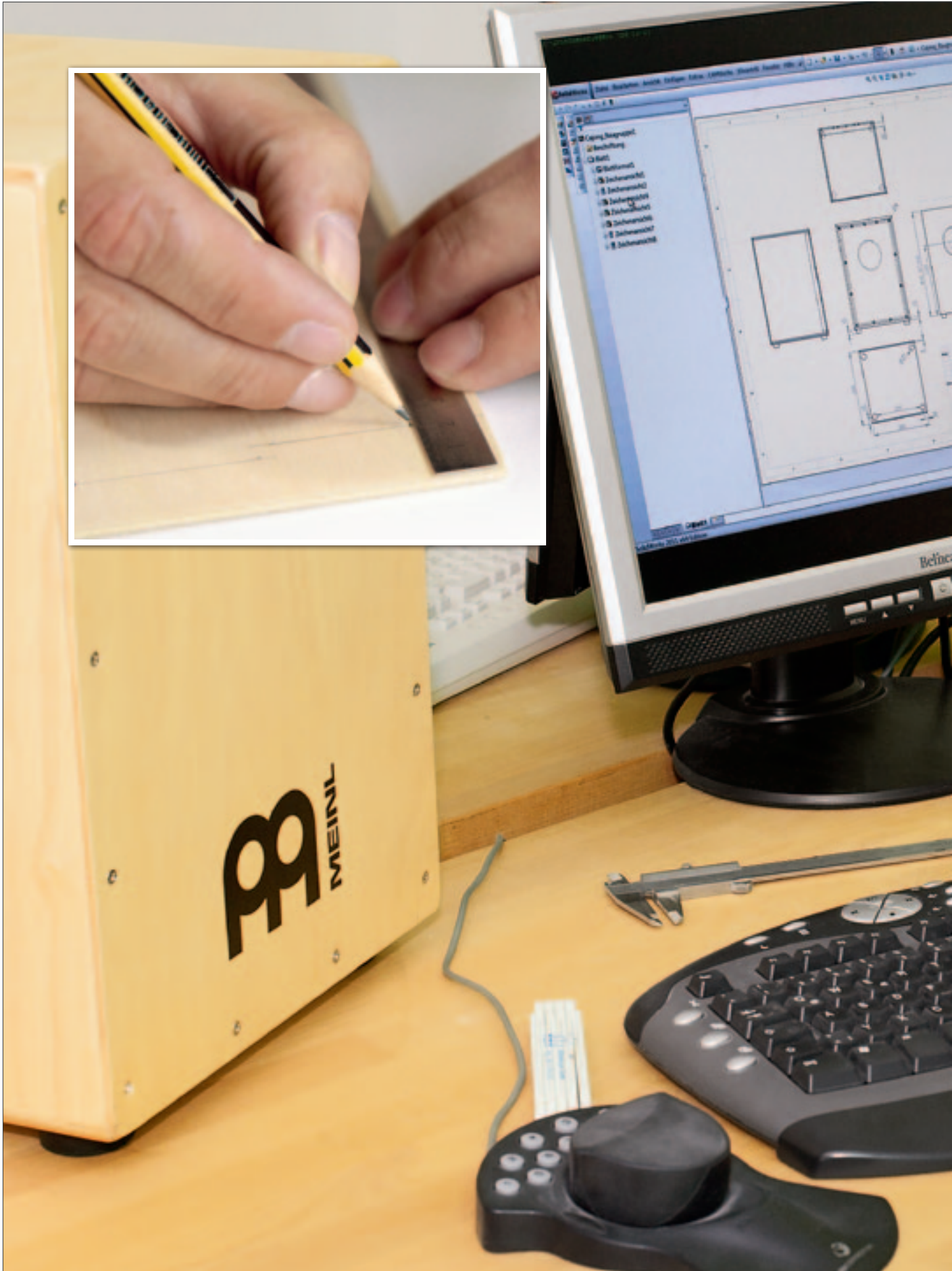

IT'S A LONG ROAD

from an idea, to a working prototype, to the finished instrument. There's a lot of testing, refining and more testing along the way.

What kind of wood to use? What size? How will all that affect the sound? And so on.

It has to come together in a way that not only sounds great, but is also playable and durable.

It's our passion for details that makes MEINL different. We put together creative people's ideas, with German engineering and modern production facilities.

MEINL has become a world leader in percussion by seeing the creative process through, from inspiration to finished instrument.

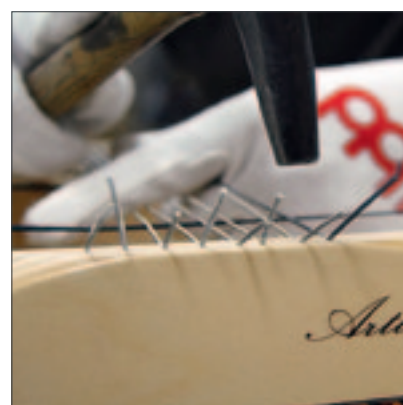
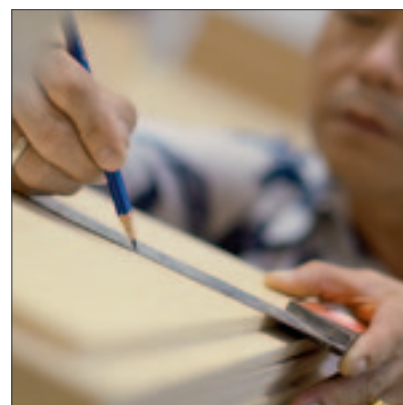



MUSIKMESSE INTERNATIONAL PRESS AWARDS

THE MIPA AWARD GOES TO...

Our Research & Development process is a collaboration between very creative people: Players and designers. We are all passionate about what we do. The MEINL Percussion approach to R & D is open-minded, straightforward, and based on mutual respect. That's how we get things done. That's why MEINL won the most MIPA awards of all percussion brands.



...the **MEINL Slap-Top Cajon**
in the category "Best Percussion Product 2012".



...the **MEINL Journey Series Rope Tuned Fiberglass Djembe**
in the category "Best Percussion Product 2011".



...the **MEINL Artist Series Hand-Bale (Taku Hirano)**
in the category "Best Percussion Product 2010".



...the **MEINL Foot Cabasa**
in the category "Best Percussion Product 2008".



...the **MEINL Conga Cajon**
in the category "Best Percussion Product 2006".



...the **MEINL Artist Series Congas (Luis Conte)**
in the category "Best Percussion Product 2005".



...the **MEINL Professional Series Congas**
in the category "Best Percussion Product 2002".



...the **MEINL Collection Series Wood Bongo**
in the category "Best Percussion Product 2001".



...the **MEINL Artist Series Timbales (Luis Conte)**
in the category "Best Percussion Product 2000".



IT'S OUR WORLD, WE CARE FOR IT

Actions speak louder than words! This is why we take our responsibility seriously and commit ourselves to several environmental projects. Our specially developed vacuum distillation saves 90,000 liters of drinking water, the world's most threatened resource. In order to minimize our electricity usage, all of our buildings are equipped with motion sensors and our centralized electricity controls prevents the waste of this resource. With our solar-power-plant (Photovoltaic-System) we produce enough power to supply 170 houses with electricity. All of the electricity used in our facility is produced from renewable energies. Thus we reduced our carbon monoxide emission from 216 tons per year down to zero. Reusable materials like paper, plastic or styrofoam are too precious to be wasted. We separate them for efficient recycling.

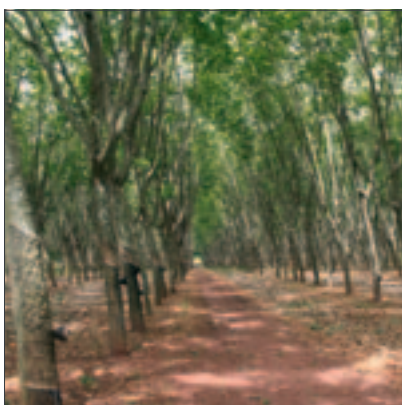

RUBBER WOOD PLANTATION FARM IN THAILAND



WOOD FROM ENVIRONMENTALLY CONTROLLED WOOD PLANTATION

Thailand is a logical manufacturing base for percussion instruments due to the fact that the *Hevea Brasiliensis*, which was indigenous to Brazil and later transported by way England to Asia, has been commercially grown in Southeast Asia during the last century on plantation farms for the production of Latex. The traditional plantation of Rubber Wood (*Hevea brasiliensis* Muell.-Arg.) meets all ecological requirements. Same counts for the plantation grown Mahogany Wood from Indonesia, which we use for our Original African Style Rope Tuned Wood Djembes. In a natural evolution, new trees are planted and the older ones, which have ceased to provide latex, are harvested. In this way, plenty of raw material is available and the valuable rain forest eco-system is preserved.

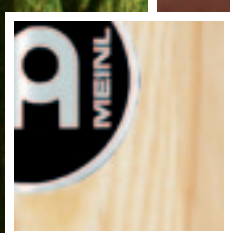

MATERIAL & ECOLOGY

Wood is a raw material which is present in almost every part of our daily life. Trees are an important part of the complex eco-system while healthy forests are imperative for the Earth's atmosphere. Only plantation grown Wood is used for the making of MEINL percussion instruments. This wood fulfils the CITES regulations ("Convention on International Trade in Endangered Species of Wild Fauna and Flora") and originates from environmentally controlled forests from industrial wood plantations.



PROTECT THE WORLD WE LIVE IN

1 ELECTRIC CAR

With a new e-car we are taking another important step towards an environmentally friendly future. The long-lasting lithium ion battery feeds the electrical driving unit of the e-car and offers eco-friendly driving enjoyment of about 80 km through saved energy.

2 CO₂ CONSERVATION

For us it goes without saying that all kinds of trash like paper, cardboard, plastic, styrofoam, organic waste, etc. are separated. As a result of this, we are a member of the official German packaging regulations organization which controls the return of the sales, transport and outer packaging that needs to be licensed in a dual system. By this recirculation of paper, cardboard and synthetic materials, we have conserved 449,238 lb (203,771 kg) of CO₂ in 2011. This equals the emission of a car driving 799,132 miles (1,286,078 km).

3 AIR HEAT PUMP

All of the exhibition area of our new multipurpose hall gets heated by an air heat pump. The fans lead the outside air through the evaporator of the heat pump where the heat gets absorbed from the air. With the outside air there is always free environmental heat available and that makes it possible for us to abandon gas and heating oil. Additionally air heating pumps reduce pollutant and carbon emissions, are long-lasting, reliable and low-maintenance.

4 SAVING ELECTRICITY

To keep our electricity usage at a minimum level, all of the buildings are equipped with motion sensors in order that lights are not left on when our employees aren't there. Additionally, a centralized lighting and machinery control panel prevents the unnecessary waste of electricity.

5 PHOTOVOLTAIC SYSTEM

Since 2003 we have operated our own photovoltaic power plants which have increasingly grown in size to this very day. Today all of our six solar facilities generate a total of 513,000 kilowatt hours of electricity per year. This equals a CO₂ conservation of 565,485 lb (256,500 kg). With this generated energy we are able to supply 170 households with electricity, or cover more than half of our own power consumption.

6 RENEWABLE ELECTRICITY

All of the electricity used in our facility is produced from renewable energies and comes from water power plants. By doing this we reduce the carbon monoxide emission, which the production of the electricity for our operations would cause if normal energies were used, from 200 tons per year down to zero.



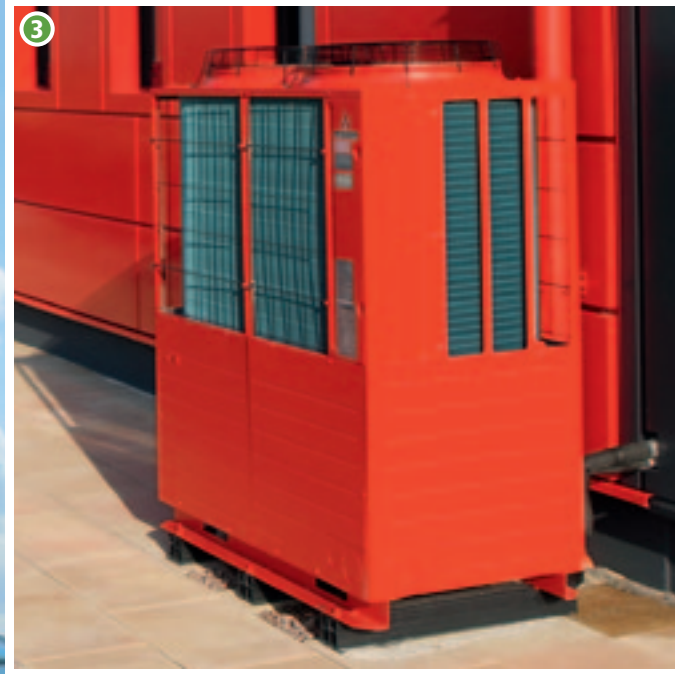

CHARGING STATION

Refuelling our new e-car is now possible at our on-site charging station. As a special service, visitors to our exhibition hall are allowed to refuel their e-cars for free. Just as with all of the power our company uses, we obtain the energy for the e-car from renewable resources.

PELLET HEATING

Since 2011 we have heated our new multipurpose hall with a pellet heater. Wood is a natural renewable source of energy which is ecologically commendable and converts the carbon-neutral power of the sun into heating energy. Besides that, wood is almost limitlessly available. Compared to other combustible materials, wood pellets emit the lowest carbon and particulate emissions and have the highest points in terms of energy efficiency.



PROTECTING THE ENVIRONMENT IS AN ESSENTIAL PART OF WHAT DEFINES US AND OUR DAY TO DAY ACTIVITIES.

At MEINL Percussion, it is of utmost importance to ensure that all of our operations are being executed utilizing the highest possible level of environmental care and preservation. When buying a MEINL Percussion instrument, you can be sure of this. You have our word.



HOW WE MAKE IT

CONGAS



01 Rubber Wood stock is sawed to desired thickness for conga staves.

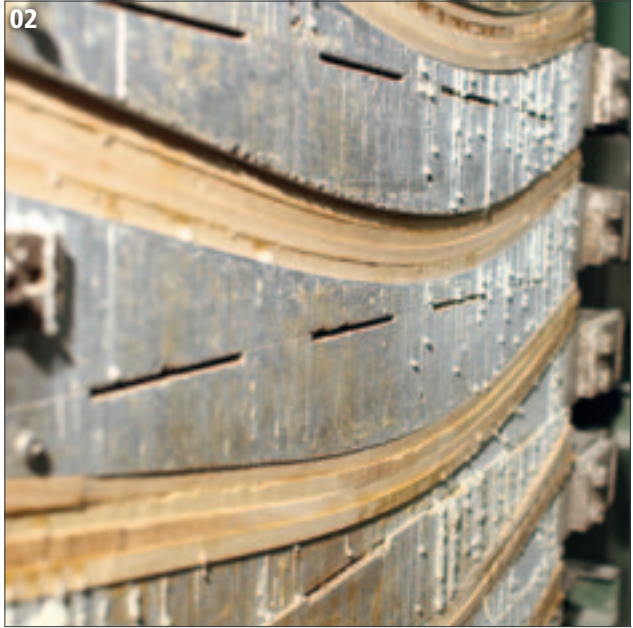

02 Glued double-layered staves are bent into shape in a large press.

03 After bending, the staves have to be carefully checked for proper shape.



04 A set of staves are pre-assembled and glued together by hand.

05 The profile is cut by lathe.

06 Conga rims are being checked and prepared for the finishing process.

07 Sanding a perfect surface is skilled work.

08 Logo is hand silk screened on a conga head.

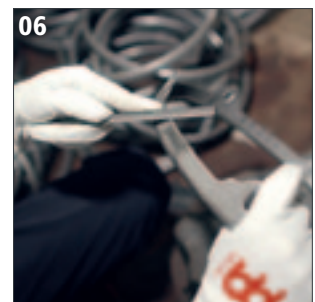





HEADLINER® SERIES CONGAS

HAND SELECTED BUFFALO HEADS



BLACK POWDER COATED 2 MM ROUNDED RIM



8 MM STRONG TUNING LUGS



ERGO ARCHED RUBBER BRACING



THESE CONGAS COME WITH HEIGHT ADJUSTABLE BASKET STANDS



RUBBER RINGED BOTTOM FOR MORE STABILITY WHEN PLAYED WITHOUT STANDS



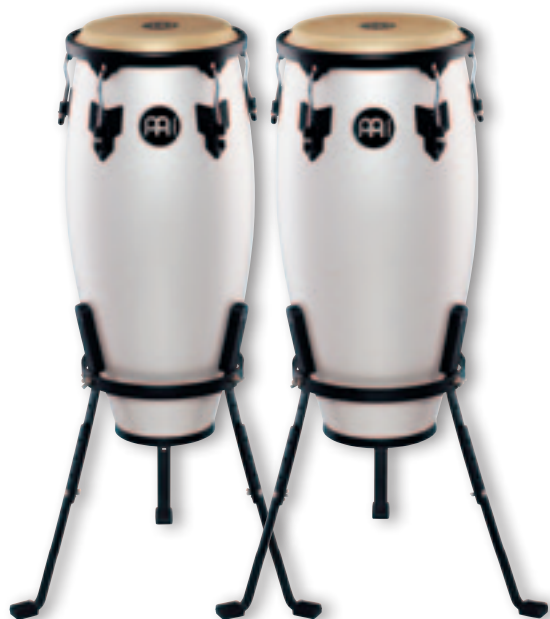

Pearl White, 10" & 11"
HC555PW



Pearl White, 11" & 12"
HC512PW



Maple, 10" & 11"
HC555MA



Maple, 11" & 12"
HC512MA

HEADLINER® SERIES CONGAS

The 10" & 11" pair is the perfect set of congas to get you started! The compact size is easy for young players to handle, light to carry, and has a full, rich sound. You can develop a full foundation of conga techniques and rhythms with these student-friendly drums. The 11" & 12" pair is a full-sized entry level conga set. They have superb projection, warm tones, light weight and features found on professional congas. They offer outstanding quality and great value in the budget price range. This is a pair of congas you will want to keep around as you develop your skills.

- SIZES** **HC555:** 10" & 11" conga set
HC512: 11" & 12" conga set
28" tall
- MATERIAL** Rubber Wood
(*Hevea brasiliensis* Muell.-Arg.)
- FEATURES** Hand selected buffalo heads
8 mm strong tuning lugs
Original MEINL style tuning brackets
2 mm rounded rims
Black powder coated hardware
- INCLUDES** Height adjustable basket stands (patented) with quick set up system
Tuning key

- COLOURS** **MA:** Maple
PW: Pearl White
- FINISH** High gloss
- PATENTS** Basket Stand patents:
Ergo arched rubber bracing
(CN, DE, US patent)
U-shaped notch (US patent)
L-shaped leg (DE patent)

MEINL HEADLINER® SERIES CONGAS

1



Black, 10" & 11"
HC555BK



Black, 11" & 12"
HC512BK



Wine Red Burst, 10" & 11"
HC555WRB



Wine Red Burst, 11" & 12"
HC512WRB

1 HEADLINER® SERIES CONGAS

The 10" & 11" pair is the perfect set of congas to get you started! The compact size is easy for young players to handle, light to carry, and has a full, rich sound. You can develop a full foundation of conga techniques and rhythms with these student-friendly drums. The 11" & 12" pair is a full-sized entry level conga set. They have superb projection, warm tones, light weight and features found on professional congas. They offer outstanding quality and great value in the budget price range. This is a pair of congas you will want to keep around as you develop your skills.

SIZES	HC555: 10" & 11" conga set HC512: 11" & 12" conga set 28" tall
MATERIAL	Rubber Wood (<i>Hevea brasiliensis</i> Muell.-Arg.)
FEATURES	Hand selected buffalo heads 8 mm strong tuning lugs Original MEINL style tuning brackets 2 mm rounded rims Black powder coated hardware
INCLUDES	Height adjustable basket stands (patented) with quick set up system Tuning key

COLOURS	BK: Black NT: Natural VS: Vintage Sunburst WRB: Wine Red Burst
FINISH	High gloss
PATENTS	Basket stand patents: Ergo arched rubber bracing (CN, DE, US patent) U-shaped notch (US patent) L-shaped leg (DE patent)



Vintage Sunburst, 10" & 11"
HC555VSB



Vintage Sunburst, 11" & 12"
HC512VSB



Natural, 10" & 11"
HC555NT



Natural, 11" & 12"
HC512NT

2 CONGA SAVERS

Available for 8 mm and 10 mm tuning lugs, the MEINL Conga Savers are placed over the conga lugs to prevent them from damaging and scratching the shell while the conga remains fully tunable.

PATENT MEINL Conga Saver (CN, TH, US patent)

2



CONGA-SAVER8

CONGA-SAVER10





HEADLINER® DESIGNER SERIES CONGAS

1

NEW!



Phantom Black, 10"
HC10PBK-M

Phantom Black, 11"
HC11PBK-M

Phantom Black, 12"
HC12PBK-M



PHANTOM BLACK



Vintage Wine Barrel, 10"
HC10VWB-M

Vintage Wine Barrel, 11"
HC11VWB-M

Vintage Wine Barrel, 12"
HC12VWB-M

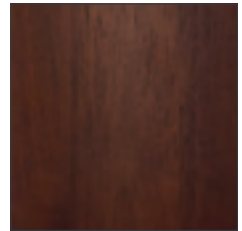

VINTAGE WINE BARREL

1 HEADLINER® DESIGNER SERIES CONGAS

These congas are offered individually, and you can make up a trio of the three singles: Nino, Quinto and Conga. These three sizes create a full tonal range.

SIZES 10" Nino, 11" Quinto, 12" Conga
28" tall

MATERIAL Rubber Wood
(*Hevea brasiliensis* Muell.-Arg.)

FEATURES Hand selected buffalo heads
8 mm strong tuning lugs
Original MEINL style tuning brackets
2 mm rounded rims
Black powder coated hardware
HTC: 5 mm traditional TTR-Rims

INCLUDES Height adjustable basket stands (patented) with quick set up system
Tuning key

DESIGNS **PBK-M:** Phantom Black
VWB-M: Vintage Wine Barrel
WB-M: Walnut Brown

FINISH Matte
PATENTS Basket stand patents:
Ergo arched rubber bracing (CN, DE, US patent)
U-shaped notch (US patent)
L-shaped leg (DE patent)



CARLOS MALDONADO, PUERTO RICO

HEADLINER® TRADITIONAL DESIGNER SERIES CONGAS



WALNUT BROWN

CONGAS

Cubano Retro, 10"
HTC10WB-M

Cubano Retro, 11"
HTC11WB-M

Cubano Retro, 12"
HTC12WB-M

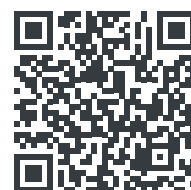

2 CONGA SOUND PLATE

The MEINL Conga Sound Plate is a sturdy wooden disc that provides a hard sound reflective surface under your conga.

SIZE 13 1/4"

MATERIAL Rubber Wood
(*Hevea brasiliensis* Muell.-Arg.)

3 CONGA RISERS

The MEINL Conga Risers are sturdy rubber feet that raise your drums off the floor to allow maximum sound projection. A set of four provides a stable base on any surface.

MATERIAL Sturdy rubber

FEATURES Comes in a set of four
Flexible construction

COLOUR **BK:** Black

2



CSP

3

FITS UNDER ANY CONGA



MCR-BK



COMES IN A SET OF 4



1 2 3 4 5 6 HEADLINER® SERIES CONGA SETS

Get started with the MEINL Headliner® Series Conga Sets. They offer outstanding quality and great value in the budget price range, yet are equipped with many features known from professional instruments. These conga sets come with a height adjustable double braced tripod stand.

- SIZES** **HC888:** 10" & 11" conga set
HC812: 11" & 12" conga set
28" tall
- MATERIAL** Rubber Wood
(*Hevea brasiliensis* Muell.-Arg.)
- FEATURES** Hand selected buffalo heads
8 mm strong tuning lugs
Original MEINL style tuning brackets
2 mm rounded rims
Black powder coated hardware
- INCLUDES** Height adjustable double braced tripod stand
Tuning key
- COLOURS** **NT:** Natural
VSB: Vintage Sunburst
WRB: Wine Red Burst
- FINISH** High gloss



JARENGTON DE LEON,
DOMINICAN REPUBLIC

5



Wine Red Burst, 10" & 11"
HC888WRB

6



Wine Red Burst, 11" & 12"
HC812WRB

7



Antique Tobacco Burst, 11" & 11 3/4"
MCC-SET-ATB-M

7 MARATHON® CLASSIC SERIES CONGA SET

The MEINL Marathon® Classic Series Conga Set combines professional features at a very attractive price. This conga set is equipped with a height adjustable double braced tripod stand.

SIZES 11" Quinto, 11 3/4" Conga
30" tall

MATERIAL Rubber Wood
(*Hevea brasiliensis* Muell.-Arg.)

FEATURES True Skin Buffalo Heads
8 mm strong tuning lugs
2.6 mm rounded SSR-Rims
Black powder coated hardware

INCLUDES Height adjustable double braced tripod stand
MEINL Conga Saver (patented)
Accessory pouch
L-shaped tuning key
Tune Up Oil

COLOUR **ATB-M:** Antique Tobacco Burst, matte

PATENT MEINL Conga Saver (CN, TH, US patent)

NEW!

NEW!

NEW!

MEINL HEADLINER® FIBERGLASS & ARTIST SERIES CONGAS

1



Black, 10"
HFC10BK

Black, 11"
HFC11BK

Black, 12"
HFC12BK

PREMIUM FIBERGLASS GUARANTEES LONG DURABILITY AND RESISTANCE TO CLIMATIC CHANGES

2



LUIS CONTE, USA

Luis Conte



Natural, 11"
LC11NT-M

Natural, 11 3/4"
LC1134NT-M

Natural, 12 1/2"
LC1212NT-M

A COMBINATION OF THE CHARM AND SOUND OF THE OLD TRADITIONAL CUBAN DRUMS WITH MODERN FEATURES AND INNOVATIONS



1 HEADLINER® FIBERGLASS SERIES CONGAS

This material has long been used for congas shells because of its durability and resistance to climactic changes, while offering a full spectrum and brilliance in sound.

- SIZES** 10" Nino, 11" Quinto, 12" Conga 28" tall
- MATERIAL** Premium fiberglass
- FEATURES** Hand selected buffalo heads
8mm strong tuning lugs
Original MEINL style tuning brackets
2mm rounded rims
Black powder coated hardware
- INCLUDES** Height adjustable basket stands (patented) with quick set up system
Tuning key
- COLOUR** **BK:** Black

2 ARTIST SERIES LUIS CONTE CONGAS

All of Luis' needs have been met and exceeded with the MEINL Artist Series Luis Conte Congas. They combine the charm and sound of the old traditional Cuban drums with modern features and innovations. These congas are equipped with traditional rims, are mounted as close to the shell as possible, and when combined with MEINL's True Skin Buffalo Heads, they enable an even more controlled sound.

- SIZES** 11" Quinto, 11 3/4" Conga, 12 1/2" Tumba 30" tall
- MATERIAL** Two ply Rubber Wood (*Hevea brasiliensis* Muell.-Arg.)
- FEATURES** True Skin Buffalo Heads
8 mm strong tuning lugs
5 mm traditional TTR-Rims
Black powder coated hardware

- INCLUDES** MEINL Conga Saver (CN, TH, US patent)
MEINL Soundpads
Accessory pouch
L-shaped tuning key
Tune Up Oil
- COLOUR** **NT-M:** Natural
- FINISH** Matte

MARATHON® DESIGNER SERIES CONGAS

1



DESIGN INSPIRED BY TAKU HIRANO, USA



Mitsudomoe, 11"
MCC11M

Mitsudomoe, 11 3/4"
MCC1134M

Mitsudomoe, 12 1/2"
MCC1212M

2



Love, Peace & Unity, 11"
MCC11LPU

Love, Peace & Unity, 11 3/4"
MCC1134LPU

Love, Peace & Unity, 12 1/2"
MCC1212LPU



DESIGN INSPIRED BY MARCIE CHAPA, USA

1 MITSUDOMOE

This Marathon® Designer Series Congas matches Taku Hirano's playing style: elegant, captivating and versatile. The congas are proudly emblazoned with the Japanese Mitsudomoe symbol, representing Man, Earth, and Heaven. The symbol became associated with the Samurai ethos, and with the art of drumming itself.

Taku explains, "The Mitsudomoe symbol has always resounded with me in that it was a link to my heritage and synonymous to not only the warriors of Japan, but also the drummers of Japan. After doing research and finding out that it was adopted by a king with the same name as myself, and that it symbolized upholding honour to the highest degree, I knew that it chose me as much as I chose it."

2 LOVE, PEACE & UNITY

Marcie Chapa sends an important message to the world with the Marathon® Designer Series Congas: "Love, Peace & Unity" "I fall in love with music each time I play," says Marcie. "Peace reminds me of where we should be. Every time I play I feel at Peace. Music has amazing powers because it is an international language that can bring Peace, Love, and Unity to us all."

SIZES	11" Quinto, 11 3/4" Conga, 12 1/2" Tumba 30" tall
MATERIAL	Rubber Wood with appliqué graphics (Hevea brasiliensis Muell.-Arg.)
FEATURES	True Skin Buffalo Heads 8 mm strong tuning lugs 2.6 mm rounded SSR-Rims Black powder coated hardware
INCLUDES	Steely II Conga Stand (patented) MEINL Conga Saver (CN, TH, US patent) Accessory pouch L-shaped tuning key Tune Up Oil
DESIGNS	LPU: Love, Peace & Unity M: Mitsudomoe
FINISH	High gloss



MARATHON® DESIGNER SERIES CONGAS

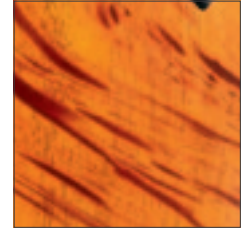

AMBER FLAME

Amber Flame, 11"
MCC11AF

Amber Flame, 11 3/4"
MCC1134AF

Amber Flame, 12 1/2"
MCC1212AF

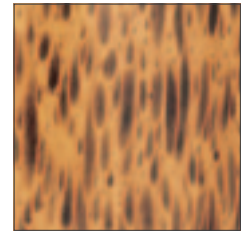

LEOPARD BURL

Leopard Burl, 11"
MCC11LB

Leopard Burl, 11 3/4"
MCC1134LB

Leopard Burl, 12 1/2"
MCC1212LB

MARATHON® DESIGNER SERIES CONGAS

The Marathon® Designer Series Congas are made with a special lacquering technique in high gloss, have professional features and are available at a very attractive price.

SIZES 11" Quinto, 11 3/4" Conga,
12 1/2" Tumba
30" tall

MATERIAL Two ply Rubber Wood
(*Hevea brasiliensis* Muell.-Arg.)

FEATURES True Skin Buffalo Heads
8 mm strong tuning lugs
2.6 mm rounded SSR-Rims
Black powder coated hardware

INCLUDES Steely II Conga Stand (patented)
MEINL Conga Saver (CN, TH, US patent)
Accessory pouch
L-shaped tuning key
Tune Up Oil

COLOURS **AF:** Amber Flame
LB: Leopard Burl

FINISH High gloss



JOANNIE LABELLE, CANADA

MARATHON® CLASSIC SERIES CONGAS



Super Natural, 11"
MCC11SNT-M

Super Natural, 11 3/4"
MCC1134SNT-M

Super Natural, 12 1/2"
MCC1212SNT-M

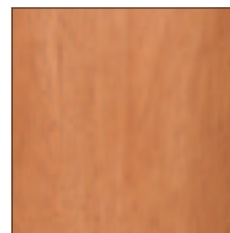

SUPER NATURAL

CONGAS



Coffee Burst, 11"
MCC11CB

Coffee Burst, 11 3/4"
MCC1134CB

Coffee Burst, 12 1/2"
MCC1212CB

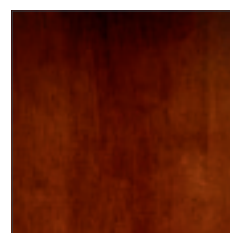

COFFEE BURST

MARATHON® CLASSIC SERIES CONGAS

The MEINL Marathon® Classic Series Congas set the standard in this price range by which other wood congas are judged. They combine professional features at a very attractive price.

SIZES 11" Quinto, 11 3/4" Conga,
12 1/2" Tumba
30" tall

MATERIAL Two ply Rubber Wood
(*Hevea brasiliensis* Muell.-Arg.)

FEATURES True Skin Buffalo Heads
8 mm strong tuning lugs
2.6 mm rounded SSR-Rims
Black powder coated hardware

INCLUDES Steely II Conga Stand (patented)
MEINL Conga Saver (patented)
Accessory pouch
L-shaped tuning key
Tune Up Oil

COLOURS **CB:** Coffee Burst, high gloss
SNT-M: Super Natural, matte

PATENTS Steely-II patents:
L-shaped leg and metal spike attachment
(DE, TH, US patent)
U-shaped notch (US patent)
Ergonomic arched rubber bracing
(CN, DE, US patent)
Notches for quick height adjustability
(DE patent)
MEINL Conga Saver (CN, TH, US patent)



THE STEELY II STAND CAN BE ADJUSTED TO HOLD CONGAS IN A TILTED POSITION



PROFESSIONAL SERIES CONGAS



BROWN BURL

Brown Burl, 11"
MP11BB

Brown Burl, 11 3/4"
MP1134BB

Brown Burl, 12 1/2"
MP1212BB



NATURAL

Natural, 11"
MP11NT

Natural, 11 3/4"
MP1134NT

Natural, 12 1/2"
MP1212NT



CHROME PLATED 4 MM ROUNDED SSR-RIM



AZTEC RED FADE

Aztec Red Fade, 11"
MP11ARF

Aztec Red Fade, 11 3/4"
MP1134ARF

Aztec Red Fade, 12 1/2"
MP1212ARF



GIOVANNI IMPARATO, ITALY

PROFESSIONAL SERIES CONGAS

The Roland Meinl Professional Series Congas are the preferred conga model by many top congueros. Outstanding in look and sound, they reach from fat basses to cutting slaps with a great warm overall tone. They set the standard in the professional conga ranges.

SIZES 11" Quinto, 11 3/4" Conga, 12 1/2" Tumba, 30" tall

MATERIAL Two ply Rubber Wood (*Hevea brasiliensis* Muell.-Arg.)

FEATURES True Skin Buffalo Heads, 10 mm strong tuning lugs, 4 mm rounded SSR-Rims, Chrome plated hardware

- INCLUDES** MEINL Conga Saver (CN, TH, US patent), MEINL Soundpads, Accessory pouch, L-shaped tuning key, Tune Up Oil
- COLOURS** **ARF:** Aztec Red Fade, **BB:** Brown Burl, **NT:** Natural
- FINISH** High gloss



TMC-CH

PROFESSIONAL CONGA STAND (SEE PAGE 166)



FIBERCRAFT SERIES CONGAS



BLUE SPARKLE

Blue Sparkle, 11"
FC11BSP

Blue Sparkle, 11 3/4"
FC1134BSP

Blue Sparkle, 12 1/2"
FC1212BSP



BLACK SPARKLE

Black Sparkle, 11"
FC11BKSP

Black Sparkle, 11 3/4"
FC1134BKSP

Black Sparkle, 12 1/2"
FC1212BKSP

FIBERCRAFT SERIES CONGAS

MEINL Fibercraft Congas offer great quality, durability, volume, and they are resistant to climatic changes. They have a great presence and brilliance in sound. Great for live playing and extensive road use.

SIZES 11" Quinto, 11 3/4" Conga,
12 1/2" Tumba
30" tall

MATERIAL Premium fiberglass

FEATURES True Skin Buffalo Heads
10 mm strong tuning lugs
4 mm rounded SSR-Rims
Chrome plated hardware

INCLUDES MEINL Conga Saver (CN, TH, US patent)

MEINL Soundpads
Accessory pouch
L-shaped tuning key
Tune Up Oil

COLOURS **BKSP**: Black Sparkle
BSP: Blue Sparkle



TRUE SKIN BUFFALO HEAD

FIBERCRAFT DESIGNER SERIES CONGAS



RAUL OVIEDO, MEXICO

CONGAS

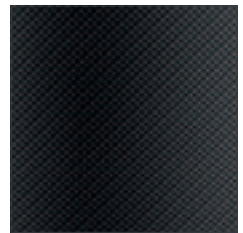

CRISP AND CLEAN CARBON FINISH

Carbon Finish, 11"
FC11CA

Carbon Finish, 11 3/4"
FC1134CA

Carbon Finish, 12 1/2"
FC1212CA



FIBERCRAFT DESIGNER SERIES CONGAS

The MEINL Fibercraft Designer Series Congas come in a dazzling carbon finish. These congas are made from premium fiberglass for dependability and great sound characteristics.

SIZES 11" Quinto, 11 3/4" Conga, 12 1/2" Tumba
30" tall

MATERIAL Premium fiberglass

FEATURES True Skin Buffalo Heads
10 mm strong tuning lugs
4 mm rounded SSR-Rims
Chrome plated hardware

INCLUDES MEINL Conga Saver (CN, TH, US patent)
MEINL Soundpads
Accessory pouch
L-shaped tuning key
Tune Up Oil

COLOUR CA: Carbon Finish



ST-MCC

ST-FL / ST-MP / ST-WC

ST-MSA

STEELY II CONGA STANDS (SEE PAGE 166)



FLOATUNE & ARTIST SERIES CONGAS

1



Brown Burl, 10"
FL10BB

Brown Burl, 11"
FL11BB

Brown Burl, 12"
FL12BB

Brown Burl, 13"
FL13BB

THE FLOATUNE TUNING SYSTEM
ALLOWS THE SHELL TO VIBRATE FREELY.

2



American White Ash, 11"
MSA11AWA

American White Ash, 11 3/4"
MSA1134AWA

American White Ash, 12 1/2"
MSA1212AWA



Ramon Santamaria

RAMON "MONGO" SANTAMARIA, CUBA

1 FLOATUNE SERIES CONGAS

The MEINL Floatune Tuning System is a true and unique MEINL innovation. All mounting hardware is completely isolated from the shell. This avoids the need to drill through the shell and mount hardware with bolts, which reduces the resonant vibrations of the shell.

SIZES 10" Nino, 11" Quinto, 12" Conga, 13" Tumba
30" tall

MATERIAL Two ply Rubber Wood
(*Hevea brasiliensis* Muell.-Arg.)

FEATURES Floatune Tuning System
True Skin Buffalo Heads
10 mm strong tuning lugs
4 mm rounded SSR-Rims
Chrome plated hardware

INCLUDES MEINL Conga Saver (CN, TH, US patent)
MEINL Soundpads
Accessory pouch
L-shaped tuning key
Tune Up Oil

COLOUR **BB:** Brown Burl
FINISH High gloss

2 ARTIST SERIES CONGAS (RAMON "MONGO" SANTAMARIA)

Ramon "Mongo" Santamaria was without a doubt one of the most respected conga players ever, and a pioneer of modern Latin Jazz. During the 50's his band "Black Cuban Diamonds" laid down the foundation for an outstanding career.

Ramon recorded dozens of legendary percussion albums. Worldwide Jazz hits, such as "Watermelon Man" in 1963 and the album "Summertime" from 1980 are only two of the many recordings from this great master percussionist. Mongo has inspired more percussionists around the globe than any other conguero.

Mongo Santamaria died at the Baptist Hospital in Miami, USA in February 2003. He was 85 years old. It is with great appreciation and deepest respect that we honour our friend and his life's work with his MEINL Artist Series Mongo Santamaria Congas.

WOODCRAFT SERIES CONGAS

3



ZEBRA FINISHED ASH

Zebra Finished Ash, 11"
WC11ZFA-M

Zebra Finished Ash, 11 3/4"
WC1134ZFA-M

Zebra Finished Ash, 12 1/2"
WC1212ZFA-M

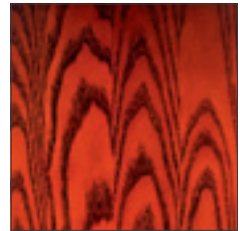

ANTIQUÉ MAHOGANY BURST

Antique Mahogany Burst, 11"
WC11AMB

Antique Mahogany Burst, 11 3/4"
WC1134AMB

Antique Mahogany Burst, 12 1/2"
WC1212AMB

SIZES 11" Quinto, 11 3/4" Conga, 12 1/2" Tumba
30" tall

MATERIAL Two ply American White Ash (*Fraxinus americana* L.)

FEATURES True Skin Buffalo Heads
10 mm strong tuning lugs
4 mm rounded SSR-Rims
Gold tone hardware

INCLUDES MEINL Conga Saver (CN, TH, US patent)
MEINL Soundpads
Accessory pouch
L-shaped tuning key
Tune Up Oil

COLOUR FINISH **AWA:** American White Ash
High gloss

3 WOODCRAFT SERIES CONGAS

The MEINL Woodcraft Series Congas stand for tradition combined with exceptional workmanship. Only the finest hand selected materials are used to produce these premium drums. Their "Cuban Style" shells provide a broad range of different tonal characteristics.

SIZES 11" Quinto, 11 3/4" Conga, 12 1/2" Tumba
30" tall

MATERIAL Two ply American White Ash (*Fraxinus americana* L.)

FEATURES True Skin Buffalo Heads
10 mm strong tuning lugs
5 mm traditional TTR-Rims
Chrome plated hardware

INCLUDES MEINL Conga Saver (CN, TH, US patent)
MEINL Soundpads
Accessory pouch
L-shaped tuning key
Tune Up Oil

COLOURS **AMB:** Antique Mahogany Burst, high gloss
ZFA-M: Zebra Finished Ash, matte



BONGOS



01 Staves are matched for colour and grain.

02 The staves are laid up with glue.

03 After being glued, the staves are assembled into a hollow wooden block by hand.

04 The Macho and Hembra are cut into two separate pieces.

05 Precision is a must.

06 The footing profile is also cut on the lathe.

07 The surface and edges are hand-sanded.

08 Our proprietary Free Ride System allows the bongo to resonate freely because there are no bolts or holes drilled through the shells.

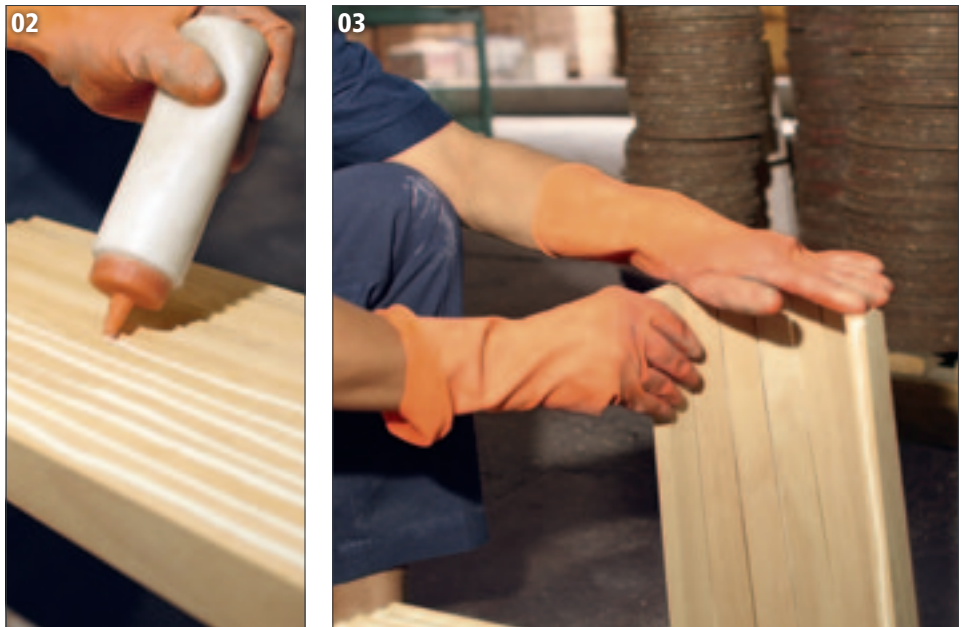
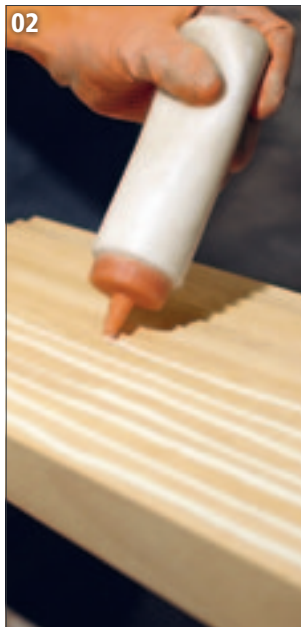



MEINL HEADLINER® SERIES BONGOS

1



Black, 6 1/2" & 7 1/2"
HB50BK

STURDY ABS PLASTIC

2



Pearl White, 6 3/4" & 8"
HB100PW



ROLAND PEIL, GERMANY



Natural, 6 3/4" & 8"
HB100NT



Maple, 6 3/4" & 8"
HB100MA



Wine Red Burst, 6 3/4" & 8"
HB100WRB



Vintage Sunburst, 6 3/4" & 8"
HB100VSB

THE COMPACT SIZE MAKES THEM HANDY AND PORTABLE

1 HEADLINER® SERIES HB50 ABS BONGO

The MEINL Headliner® Series ABS Bongo has the features of traditional bongos, made from sturdy ABS plastic. The compact size makes it handy and portable.

SIZES 6 1/2" Macho & 7 1/2" Hembra

MATERIAL ABS plastic

FEATURES Hand selected buffalo heads
Rounded rims for playing comfort
Black powder coated hardware

INCLUDES Tuning key

COLOUR **BK:** Black

SIZES 6 3/4" Macho & 8" Hembra
MATERIAL Rubber Wood
(*Hevea brasiliensis* Muell.-Arg.)

FEATURES Hand selected buffalo heads
8 mm strong tuning lugs
2 mm rounded rims
Black powder coated hardware
Interior backing plates

INCLUDES Tuning key

COLOURS **MA:** Maple
NT: Natural
PW: Pearl White
VSB: Vintage Sunburst
WRB: Wine Red Burst

FINISH High gloss

2 HEADLINER® SERIES HB100 WOOD BONGOS

Headliner® Series Wood Bongos are perfect for the student or hobbyist who is looking for a high quality instrument right from the beginning.

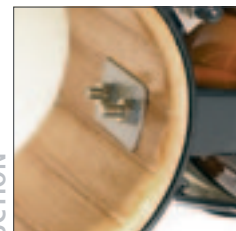

INTERIOR BACKING PLATE
ADDS STRENGTH TO
CONSTRUCTION

TRADITIONAL SOLID
WOODBLOCK CONSTRUCTION

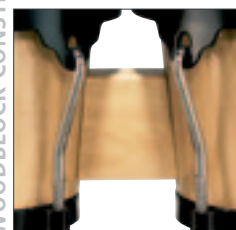

3



Black, 6 3/4" & 8"
HFB100BK

PREMIUM FIBERGLASS



4



Phantom Black, 6 3/4" & 8"
HB100PBK-M

NEW!

5



Acrylic, 6 1/2" & 7 1/2"
HB50A

CRYSTAL CLEAR ACRYLIC SHELLS



Vintage Wine Barrel, 6 3/4" & 8"
HB100VWB-M



Walnut Brown, 6 3/4" & 8"
HTB100WB-M

5MM STRONG TTR-RIMS



THBS-BK

THBS

HEADLINER® SERIES BONGO STANDS (SEE PAGE 167)

3 HEADLINER® SERIES HFB100 FIBERGLASS BONGO

This Bongo has all the traditional features and sounds of a wooden bongo, yet in a rugged and stable premium fiberglass body. It's perfect for the students or hobbyists who are looking for durability from their drum.

- SIZES** 6 3/4" Macho & 8" Hembra
- MATERIAL** Premium fiberglass
- FEATURES** Hand selected buffalo heads
8 mm strong tuning lugs
2 mm rounded rims
Black powder coated hardware
- INCLUDES** Tuning key
- COLOUR** **BK**: Black

4 HEADLINER® DESIGNER SERIES HB100/HTB100 WOOD BONGOS

The MEINL Headliner® Designer Series Bongos offer three finishes. The construction is in the traditional style, with a solid woodblock connection.

- SIZES** 6 3/4" Macho & 8" Hembra
- MATERIAL** Rubber Wood
(*Hevea brasiliensis* Muell.-Arg.)
- FEATURES** Hand selected buffalo heads
Rounded rims for playing comfort
Black powder coated hardware
HTB: 5 mm strong TTR-rims
- INCLUDES** Tuning key
- COLOURS** **PBK-M**: Phantom Black, matte
VWB-M: Vintage Wine Barrel, matte
WB-M: Walnut Brown, matte

5 HEADLINER® SERIES HB50 ACRYLIC BONGO

The MEINL Headliner® Series Acrylic Bongo has a great look. The crystal clear acrylic shells add a touch of transparency and lightness. The shells are joined together in the traditional style.

- SIZES** 6 1/2" Macho & 7 1/2" Hembra
- MATERIAL** Acrylic
- FEATURES** Hand selected buffalo heads
Rounded rims for playing comfort
Black powder coated hardware
- INCLUDES** Tuning key
- FINISH** Transparent



FREE RIDE SERIES WOOD BONGOS

1



Super Natural, 6 3/4" & 8"
FWB190SNT-M

2



Leopard Burl, 6 3/4" & 8"
FWB190LB

NEW!



Antique Tobacco Burst, 6 3/4" & 8"
FWB190ATB-M



Amber Flame, 6 3/4" & 8"
FWB190AF



Cherry Red, 6 3/4" & 8"
FWB190CR-M

DESIGN INSPIRED BY
TAKU HIRANO, USA



Mitsudomoe, 6 3/4" & 8"
FWB190M



Coffee Burst, 6 3/4" & 8"
FWB190CB

DESIGN INSPIRED BY
MARCIE CHAPA, USA



Love, Peace & Unity, 6 3/4" & 8"
FWB190LPU

1 FREE RIDE SERIES (DE PATENT) FWB190 WOOD BONGOS

FWB190 Free Ride Series Wood Bongos are perfect for the ambitious beginner and for those who are looking for an affordable second set. Its professional features are outstanding in this price range.

SIZES 6 3/4" Macho & 8" Hembra

MATERIAL Rubber Wood
(*Hevea brasiliensis* Muell.-Arg.)

FEATURES MEINL Free Ride Suspension System (DE patent)
Black powder coated hardware
Hand selected buffalo heads
8 mm strong tuning lugs
2.5 mm rounded SSR-Rims

INCLUDES Accessory pouch
L-shaped tuning key
Tune Up Oil

COLOURS **ATB-M:** Antique Tobacco Burst, matte
CB: Coffee Burst, high gloss
CR-M: Cherry Red, matte
SNT-M: Super Natural, matte

2 FREE RIDE DESIGNER SERIES (DE PATENT) FWB190 WOOD BONGOS

The Free Ride Designer Series Wood Bongo comes in four superb finishes. All other features are similar to the FWB190 Wood Bongos.

SIZES 6 3/4" Macho & 8" Hembra

MATERIAL Rubber Wood
(*Hevea brasiliensis* Muell.-Arg.)

FEATURES MEINL Free Ride Suspension System (DE patent)
Unique designs
Black powder coated hardware
Hand selected buffalo heads
8 mm strong tuning lugs
2.5 mm rounded SSR-Rims

INCLUDES Accessory pouch
L-shaped tuning key
Tune Up Oil

COLOURS **AF:** Amber Flame
LB: Leopard Burl
LPU: Love, Peace & Unity
M: Mitsudomoe

FINISH High gloss

ARTIST SERIES & FREE RIDE SERIES WOOD BONGOS

1



LUIS CONTE, USA



TRADITIONAL
SOLID WOODBLOCK CONSTRUCTION

Natural, 6 3/4" & 8"
LC300NT-M

BONGOS

2



Gold Amber Sunburst, 6 3/4" & 8"
FWB200GAB



Aztec Red Fade, 6 3/4" & 8"
FWB200ARF



CHROME PLATED
ROUNDED SSR RIM



Natural, 6 3/4" & 8"
FWB200NT

3



Super Natural, 3 1/2" & 4 1/4"
FWB100SNT-M

MINI!

1 ARTIST SERIES LC300 WOOD BONGO (LUIS CONTE)

The Luis Conte Wood Bongo complements his congas with its black powder coated traditional style hardware and natural finish. Luis prefers the traditional style woodblock connection between the two shells.

SIZES 6 3/4" Macho & 8" Hembra

MATERIAL Rubber Wood
(*Hevea brasiliensis* Muell.-Arg.)

FEATURES Solid woodblock connection
True Skin Cow Heads
8 mm strong tuning lugs
5 mm traditional TTR-Rims
Black powder coated hardware

INCLUDES Accessory pouch
L-shaped tuning key
Tune Up Oil

COLOUR **NT-M:** Natural, matte

2 FREE RIDE SERIES (DE PATENT) FWB200 WOOD BONGOS

The patented MEINL Free Ride System allows the bongo shells to resonate freely.

SIZES 6 3/4" Macho & 8" Hembra

MATERIAL Rubber Wood
(*Hevea brasiliensis* Muell.-Arg.)

FEATURES MEINL Free Ride Suspension System (DE patent)
Chrome plated hardware
Hand selected buffalo heads
8 mm strong tuning lugs
2.5 mm rounded SSR-Rims

INCLUDES Accessory pouch
L-shaped tuning key
Tune Up Oil

COLOURS **ARF:** Aztec Red Fade, high gloss
GAB: Gold Amber Sunburst, high gloss
NT: Natural, high gloss

3 FREE RIDE SERIES (DE PATENT) FWB100 MINI WOOD BONGO

The FWB100 is equipped with professional features.

SIZES 3 1/2" Macho & 4 1/4" Hembra

MATERIAL Rubber Wood
(*Hevea brasiliensis* Muell.-Arg.)

FEATURES Free Ride Suspension System (DE patent)
True Skin Buffalo Heads
Rounded SSR-Rims
Chrome plated hardware

INCLUDES Tuning key
COLOUR **SNT-M:** Super Natural, matte



FREE RIDE SERIES FIBERGLASS BONGOS

1



Blue Sparkle, 6 3/4" & 8"
FFB200BSP

SPARKLING EFFECT



Black Sparkle, 6 3/4" & 8"
FFB200BKSP

SPARKLING EFFECT

2

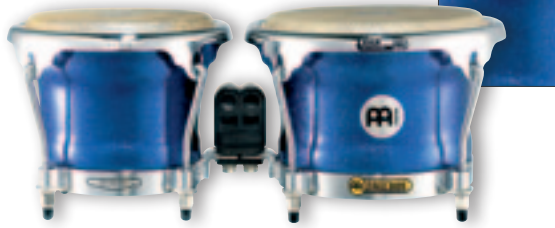

Blue Sparkle, 7" & 8 1/2"
FFB400BSP

SPARKLING EFFECT



Black Sparkle, 7" & 8 1/2"
FFB400BKSP

SPARKLING EFFECT



Carbon Finish, 7" & 8 1/2"
FFB400CA

CRISP AND CLEAN CARBON FINISH



PROFESSIONAL BONGO STAND & PROFESSIONAL BONGO STAND FOR SEATED PLAYERS (SEE PAGE 167)

TMB-S

TMB

1 FREE RIDE SERIES (DE PATENT) FFB200 FIBERGLASS BONGOS

These fiberglass bongos produce a compact sound with a nice spectrum of overtones. Ideal for the ambitious beginner who is looking for a dependable bongo at an affordable price.

SIZES 6 3/4" Macho & 8" Hembra

MATERIAL Premium fiberglass

FEATURES MEINL Free Ride Suspension System (DE patent)

Chrome plated hardware
Hand selected buffalo heads
8 mm strong tuning lugs
2.5 mm rounded SSR-Rims

INCLUDES Accessory pouch
L-shaped tuning key
Tune Up Oil

COLOURS **BKSP:** Black Sparkle
BSP: Blue Sparkle

2 FREE RIDE SERIES (DE PATENT) FFB400 FIBERGLASS BONGOS

These bongos convince with a stunning sound reaching from powerful mids to sharp highs. Thanks to their fiberglass shells they are extremely durable and the perfect instrument for the working musician on the road.

SIZES 7" Macho & 8 1/2" Hembra

MATERIAL Premium fiberglass

FEATURES MEINL Free Ride Suspension System (DE patent)

Chrome plated hardware
True Skin Cow Heads
8 mm strong tuning lugs
3 mm rounded SSR-Rims

Resonance Shaping Area
INCLUDES Accessory pouch
L-shaped tuning key
Tune Up Oil

COLOURS **BKSP:** Black Sparkle
BSP: Blue Sparkle
CA: Carbon Finish

FREE RIDE SERIES WOOD BONGOS

1



Natural, 7" & 8 1/2"
FWB400NT



Ebony Black, 7" & 8 1/2"
FWB400EBK



Cherry Red, 7" & 8 1/2"
FWB400CR



Antique Mahogany Burst, 7" & 9"
WB500AMB



Gold Amber Sunburst, 7" & 8 1/2"
FWB400GAB



Zebra Finished Ash, 7" & 9"
WB500ZFA-M



Brown Burl, 7" & 8 1/2"
FWB400BB



American White Ash, 7" & 8 1/2"
CS400AWA-M

CHROME PLATED 5 MM TRADITIONAL TTR RIM

2

3

FREE RIDE SERIES WOOD BONGOS 1 2 3

FEATURES MEINL Free Ride Suspension System (DE patent)
Chrome plated hardware
True Skin Cow Heads
8 mm strong tuning lugs
Resonance Shaping Area

INCLUDES Accessory pouch
L-shaped tuning key
Tune Up Oil

SIZES 7" Macho & 8 1/2" Hembra

MATERIAL Rubber Wood
(*Hevea brasiliensis* Muell.-Arg.)

FEATURES 3 mm rounded SSR-Rims

COLOURS **BB:** Brown Burl
CR: Cherry Red
EBK: Ebony Black
GAB: Gold Amber Sunburst
NT: Natural

FINISH High gloss

SIZES 7" Macho & 9" Hembra

MATERIAL American White Ash
(*Fraxinus americana* L.)

FEATURES 5 mm traditional TTR-Rims

COLOURS **AMB:** Antique Mahogany Burst, high gloss
ZFA-M: Zebra Finished Ash, matte

3 FREE RIDE COLLECTION SERIES (DE PATENT) CS400 WOOD BONGO

This is the finest bongo available today! It is made entirely by hand and exhibit unparalleled sound, charm, and workmanship.

SIZES 7" Macho & 8 1/2" Hembra

MATERIAL American White Ash
(*Fraxinus americana* L.)

FEATURES 3 mm rounded SSR-Rims

COLOUR **AWA-M:** American White Ash

FINISH Matte

1 FREE RIDE SERIES (DE PATENT) FWB400 WOOD BONGOS

The MEINL FWB400 Free Ride Series Wood Bongos are the preferred bongo model by many top percussionists. Exceptional sound qualities combined with a wide variety of colours make it the perfect bongo for the working musician.

2 FREE RIDE SERIES (DE PATENT) WB500 WOODCRAFT BONGOS

MEINL Woodcraft Bongos, just as the Woodcraft Congas, stand for tradition combined with exceptional workmanship. Only the finest hand selected materials are used to produce this premium bongos which produce the authentic loud bongo slap.

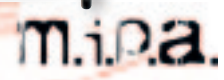



HOW WE MAKE IT

THE NEW MEINL RAPC (RADIAL PLY CONSTRUCTION) BONGOS

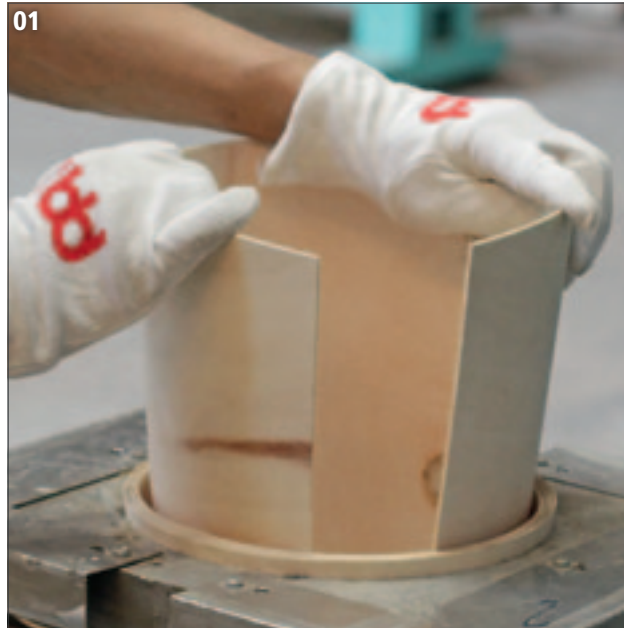

MEINL'S NEW RAPC (RADIAL PLY CONSTRUCTION) FEATURES 5 LAYERS THAT CREATE SUPER STRONG BUT LIGHTWEIGHT BONGO SHELLS WITH ENHANCED RESONANCE.



01 Preparing single wood layers for the Radial Ply Construction.

02 The thin wood layers are placed in the form to set.

03 Quality control check of each MEINL Bongo before it gets packed.



MEINL RAPC BONGOS



NEW!

Black Maple Burst, 6 3/4" & 8"
MB400BKMB



NEW!

Cherry, 6 3/4" & 8"
MB400CHE



NEW!

Ebony Black, 6 3/4" & 8"
MB400EBP



NEW!

Bubinga, 6 3/4" & 8"
MB400BU

NEW!



Desert Burl, 6 3/4" & 8"
MB400DB-M

RAPC (RADIAL PLY CONSTRUCTION) BONGOS (DE PATENT)

MEINL's new Radial Ply Construction was adopted from traditional drum-set shell building techniques. It uses several thin layers of wood being formed together to make a super strong shell that is lighter and more resonant. Add to that Meinl's patented Free Ride system that allows the bongos to be joined with NO HOLES DRILLED IN THE SHELLS and you have some serious bongo innovation.

- SIZES** 6 3/4" Macho & 8" Hembra
- MATERIAL** 5 layers of plywood
- FEATURES** MEINL Free Ride Suspension System (DE patent)
RAPC Technology
True Skin Cow Heads
8 mm strong tuning lugs
2.5 mm rounded SSR-Rims
- INCLUDES** Accessory pouch
L-shaped tuning key
Tune Up Oil
- FINISHES** **BKMB:** Black Maple Burst, high gloss
BU: Bubinga, high gloss
CHE: Cherry, high gloss
DB-M: Desert Burl, matte
EBP: Ebony Black, high gloss



HOW WE MAKE IT

DJEMBES

01 Raw logs of plantation grown Mahogany Wood.

02 Mahogany logs are scaled rough-cut.

03 First phase of shaping the djembe on a lathe.

04 The interior is hollowed out.

05 This is how the djembes look after being turned on the lathe. The central core is later removed.

06 The djembes are hand-carved. There is no substitute for this level of craftsmanship.

07 The inside of the bowl is hand-carved which tunes and shapes the sound.

08 The goatskin head goes on and the tuning ropes are tightened.

09 The extra tuning rope is tied into a carrying strap.

10 Hand-carved design on our Professional African Style Djembes.

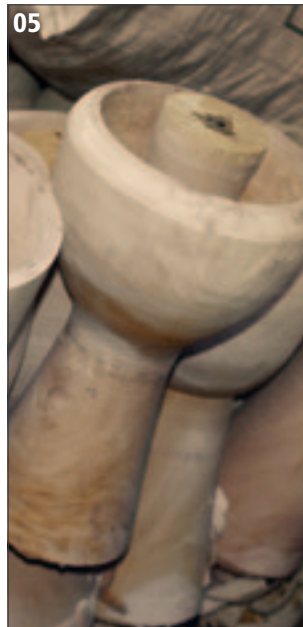

07



10A



08



10B



09





HEADLINER® SERIES ROPE TUNED WOOD DJEMBES

1



Nile Series, 13"
HDJ4-XL



Nile Series, 12"
HDJ4-L



Nile Series, 10"
HDJ4-M



Nile Series, 8"
HDJ4-S

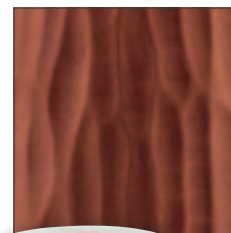

NILE SERIES

2



Black River Series, 13"
HDJ3-XL



Black River Series, 12"
HDJ3-L



Black River Series, 10"
HDJ3-M



Black River Series, 8"
HDJ3-S



BLACK RIVER SERIES

HEADLINER® SERIES ROPE TUNED WOOD DJEMBES 1 2 3 4

- SIZES**
- S:** 8" diameter, 15 3/4" tall
 - M:** 10" diameter, 20" tall
 - L:** 12" diameter, 24" tall
 - XL:** 13" diameter, 25" tall
- PP ROPES**
- S:** 4 mm thickness, 16 runners
 - M:** 4 mm thickness, 18 runners
 - L:** 5 mm thickness, 20 runners
 - XL:** 6 mm thickness, 24 runners

1 NILE SERIES

The hand carved shells feature a gouged surface reminiscent of sun-dappled water. This texture makes the djembe easy to grip between the knees. Hand selected goat heads are secured by the traditional Mali-weave system and runners of pre-stretched nylon PP rope.

- MATERIAL** Mahogany Wood
- FEATURES** Carved from one solid piece of plantation grown Mahogany Wood
Hand selected goat heads
Pre-stretched nylon PP ropes
Hand carved shells

COLOUR Brown

2 BLACK RIVER SERIES

These Djembes are made from a solid piece of plantation grown Mahogany wood, and are hand carved with a horizontal ripple motif that suggests a flowing river. This also makes the djembe easy to grip between the knees. The hand selected goat skin head is secured and tuned with the traditional Mali Weave system.

- MATERIAL** Mahogany Wood
- FEATURES** Carved from one solid piece of plantation grown Mahogany Wood
Hand selected goat heads
Pre-stretched PP nylon ropes
Hand carved shells

COLOUR Black

3



CONGO SERIES

NEW!

Congo Series, 13"
HDJ1-XL

Congo Series, 12"
HDJ1-L

Congo Series, 10"
HDJ1-M

Congo Series, 8"
HDJ1-S

4



TRIBAL SERIES

NEW!

Tribal Series, 13"
HDJ2-XL

Tribal Series, 12"
HDJ2-L

Tribal Series, 10"
HDJ2-M

Tribal Series, 8"
HDJ2-S

3 CONGO SERIES

These djembes are carved from one solid piece of plantation grown Mahogany Wood and feature the traditional Mali Weave tuning system.

MATERIAL Mahogany Wood

FEATURES Carved from one solid piece of plantation grown Mahogany Wood
Hand selected goat heads
Pre-stretched PP nylon ropes
Hand carved shells
Ornamental carving

COLOUR Dark Brown

4 TRIBAL SERIES

The black Tribal Series are painted with an African style design and feature the traditional Mali Weave tuning system. The body is made out of one solid piece of Mahogany Wood.

MATERIAL Mahogany Wood

FEATURES Carved from one solid piece of plantation grown Mahogany Wood
Hand selected goat heads
Pre-stretched PP nylon ropes
Hand painted shells

COLOUR Black with tribal painting



PRINCE AKONGO, TOGO



ROPE TUNED WOOD DJEMBES



DONG KEXIN, CHINA

1



WATER RHYTHM SERIES

13", bundle with bag MDJB-M
ADJ2-XL+BAG

12", bundle with bag MDJB-M
ADJ2-L+BAG

10", bundle with bag MDJB-S
ADJ2-M+BAG

1 ORIGINAL AFRICAN STYLE ROPE TUNED WOOD DJEMBES

These djembes are carved from one solid piece of plantation grown Mahogany Wood. These high quality instruments are crafted with great attention to detail and provide an outstanding, full-volume sound. We offer these drums in three different series: The Earth Rhythm Series features a carved design in black and brown. Its earthy pattern is evocative of ploughed fields and stalks of grain. The Moon Rhythm Series features a carved design in a dark mystic finish. The Water Rhythm Series features a carved design evocative of ocean waves, and all djembes come bundled with the Professional MEINL Djembe Bag.

- SIZES** **M:** 10" (9 1/4" – 10 1/4") diameter, 20" tall
L: 12" (10 3/4" – 12 1/4") diameter, 24" tall
XL: 13" (12 3/4" – 13 3/4") diameter, 25" tall
- HTP ROPES** **M:** 4 mm thickness, 25 runners
L: 4 mm thickness, 35 runners
XL: 5 mm thickness, 35 runners
- MATERIAL** Mahogany Wood
- FEATURES** Carved from one solid piece of plantation grown Mahogany Wood
Hand selected goat heads
Pre-stretched HTP nylon ropes
Hand carved shells
Ornamental carving
- INCLUDES** Professional Djembe Bag made out of heavy duty padded nylon
- COLOURS** **ADJ2:** Brown
ADJ3: Brown/Black
ADJ4: Black



BRYAN BROCK, USA

EARTH RHYTHM SERIES



13", bundle with bag MDJB-M
ADJ3-XL+BAG

12", bundle with bag MDJB-M
ADJ3-L+BAG

10", bundle with bag MDJB-S
ADJ3-M+BAG

MOON RHYTHM SERIES



13", bundle with bag MDJB-M
ADJ4-XL+BAG

12", bundle with bag MDJB-M
ADJ4-L+BAG

10", bundle with bag MDJB-S
ADJ4-M+BAG

2 KESSING

The Kessing is a traditional djembe accessory that provides a dry rattling accompaniment to the drum. It slides securely into the webbing and is removable.

SIZE Medium
MATERIAL Aluminum

2



KES-01



BOUGARABOU & PROFESSIONAL DJEMBES



Brown, 12"
ABGB-L

INTRICATE CARVING
HAND SELECTED COW HEAD



Traditional style hewn, 12"
PROADJ1-L

TRADITIONAL STYLE HEWN



"Village" carving, 12"
PROADJ2-L

SPECIAL "VILLAGE" CARVING



"African Queen" carving, 12"
PROADJ4-L

"AFRICAN QUEEN" CARVING



Deluxe carving, 14"
PROADJ3-XXL

DELUXE CARVING



TMD

PROFESSIONAL DJEMBE STAND (SEE PAGE 168)

1 AFRICAN BOUGARABOU

The MEINL Bougarabou is proudly made in the tradition of the Jola people of southern Senegal. The classic bougarabou features an elongated goblet-shaped body carved from Mahogany Wood. A bougarabou can be played with traditional conga or djembe techniques, and makes a rich complement within drum ensembles.

SIZE L: 12" (10 3/4" – 12 1/4") diameter, 24" tall

HTP ROPE L: 5 mm thickness, 22 runners

MATERIAL Mahogany Wood

FEATURES Carved from one solid piece of plantation grown Mahogany Wood
Hand selected cow head
Pre-stretched HTP nylon rope
Intricate carving

COLOUR Brown

PROFESSIONAL AFRICAN STYLE DJEMBES

2 3 4

The MEINL Professional African Djembes are expertly hewn from a solid piece of plantation grown Mahogany Wood, and fitted with a hand selected goatskin head. We use the traditional Mali Weave tuning system with high quality HTP rope.

MATERIAL Mahogany Wood

COLOUR Brown

2 PROFESSIONAL DJEMBE

SIZE L: 12" (10 3/4" – 12 1/4") diameter, 24" tall

HTP ROPE L: 4 mm thickness, 35 runners

FEATURES Carved from one solid piece of plantation grown Mahogany Wood
Hand selected goat heads
Pre-stretched HTP nylon rope
Traditional style hewn

3 "VILLAGE" DJEMBE

SIZE L: 12" (10 3/4" – 12 1/4") diameter, 24" tall

HTP ROPE L: 4 mm thickness, 35 runners

FEATURES Carved from one solid piece of plantation grown Mahogany Wood
Hand selected goat heads
Pre-stretched HTP nylon rope

4 "AFRICAN QUEEN" DJEMBE

SIZE L: 12" (10 3/4" – 12 1/4") diameter, 24" tall

HTP ROPE L: 4 mm thickness, 35 runners

FEATURES Carved from one solid piece of plantation grown Mahogany Wood
Hand selected goatskin head
Pre-stretched 4 mm HTP Nylon rope
Special "African Queen" carving

DJEMBEFOLAS

6

NEW!



Tiki Black, 12"
DJFS1-L

NEW!



Tiki Black, 10"
DJFS1-M



THE HEADS OF OUR
DJEMBEFOLAS ARE
MADE USING THE
HIGHEST GRADE
HIDES AVAILABLE.

HOW WE MAKE IT

DJEMBES

5 ARTISAN EDITION DJEMBE

This Djembe is hand carved from a solid plantation grown Mahogany log, and exquisitely carved with figures from the Ramayama, the epic Hindu legend and love story of Rama and Sita. Each djembe is a work of art. We make sure it sounds as good as it looks with top quality hand-selected goat skin heads, and the best pre-stretched HTP rope. We cherish our Artisan Edition Djembes as a collectors item, and so will you.

SIZE **XXL:** 14" (13 3/4" – 15 1/4") diameter, 26" tall

HTP ROPE **XXL:** 5 mm thickness, 40 runners

MATERIAL Mahogany Wood

FEATURES Carved from one solid piece of plantation grown Mahogany Wood
Hand selected goat heads
Pre-stretched HTP nylon rope
Deluxe carving

COLOUR Brown

6 DJEMBEFOLA

The MEINL Djembefola is a top-of-the line drum, carved from one solid piece of plantation grown Mahogany Wood and comes with a double rope runner tuning system. The heads of these drums are made using the highest grade hides available – selected for uniform thickness to give consistent warm tone and response. The shape of the instrument is different from other MEINL djembes and it is carved out on the inside to create the best possible sound projection.

SIZES **M:** 10" (9 1/4" – 10 1/4") diameter, 20" tall

L: 12" (10 3/4" – 12 1/4") diameter, 24" tall

HTP ROPES **M:** 4 mm thickness, 30 runners

L: 5 mm thickness, 40 runners

MATERIAL Mahogany Wood

FEATURES Carved from one solid piece of plantation grown Mahogany Wood
Highest grade goat heads
Special shape keeps the tuning longer
Carved out on the inside for better sound
Pre-stretched HTP nylon rope

COLOUR Tiki Black



ROPE TUNED FIBERGLASS DJEMBES

1



Pharaoh's Script, 12"
FADJ1-L

Pharaoh's Script, 10"
FADJ1-M



Kenyan Quilt, 12"
FADJ2-L

Kenyan Quilt, 10"
FADJ2-M



SYNTHETIC HEAD

NEW!

NEW!

NEW!



Natural Black, 12"
FADJ5-L

Natural Black, 10"
FADJ5-M



Earth Brown, 12"
FADJ6-L

Earth Brown, 10"
FADJ6-M



Crimson Red, 12"
FADJ7-L

Crimson Red, 10"
FADJ7-M

1 JOURNEY SERIES ROPE TUNED FIBERGLASS DJEMBES, SYNTHETIC HEAD

The MEINL Journey Series Rope Tuned Fiberglass Djembe with synthetic head is an ultra-light weather-proof instrument that is perfect for outdoor sessions. These M.I.P.A. award winning drums convince with fat bass tones and cutting slaps.

SIZES **M:** 10" diameter, 18" tall
L: 12" diameter, 24" tall

MATERIALS Premium fiberglass
Synthetic head

FEATURES 100% synthetic are perfect for outdoor playing
Light weight fiberglass construction makes them easy to carry
Modern materials means they are unaffected by the weather
Pre-stretched PP nylon ropes

FINISHES **FADJ1:** Pharaoh's Script
FADJ2: Kenyan Quilt
FADJ5: Natural Black
FADJ6: Earth Brown
FADJ7: Crimson Red



SHYAM EDWANKAR, INDIA

2

NEW! NEW!



HAND SELECTED GOAT HEAD

Pharaoh's Script, 12"
FADJ1-L-G

Pharaoh's Script, 10"
FADJ1-M-G

Kenyan Quilt, 12"
FADJ2-L-G

Kenyan Quilt, 10"
FADJ2-M-G

NEW! NEW! NEW!



Natural Black, 12"
FADJ5-L-G

Natural Black, 10"
FADJ5-M-G

Earth Brown, 12"
FADJ6-L-G

Earth Brown, 10"
FADJ6-M-G

Crimson Red, 12"
FADJ7-L-G

Crimson Red, 10"
FADJ7-M-G

2 JOURNEY SERIES ROPE TUNED FIBERGLASS DJEMBES, GOAT HEAD

The MEINL Journey Series Rope Tuned Fiberglass Djembe with hand selected goat head is the perfect instrument for drum circles due to their light weight but durable construction. The goat head produces warm bass tones and cutting slaps.

SIZES **M:** 10" diameter, 18" tall
L: 12" diameter, 24" tall

MATERIALS Premium fiberglass
Hand selected goat head

FEATURES Goat heads for warm tones
Light weight fiberglass construction makes them easy to carry
Pre-stretched PP nylon ropes

FINISHES **FADJ1:** Pharaoh's Script
FADJ2: Kenyan Quilt
FADJ5: Natural Black
FADJ6: Earth Brown
FADJ7: Crimson Red



STDJST-BK

TRAVEL DJEMBE STAND (SEE PAGE 168)



MECHANICAL TUNED FIBERGLASS DJEMBES

1

NEW! NEW!



Pharaoh's Script, 12"
FMDJ1-L-F



Pharaoh's Script, 10"
FMDJ1-M-F



Kenyan Quilt, 12"
FMDJ2-L-F



Kenyan Quilt, 10"
FMDJ2-M-F



SYNTHETIC HEAD

NEW! NEW!

NEW!



Natural Black, 12"
FMDJ5-L-F



Natural Black, 10"
FMDJ5-M-F



Earth Brown, 12"
FMDJ6-L-F



Earth Brown, 10"
FMDJ6-M-F



Crimson Red, 12"
FMDJ7-L-F



Crimson Red, 10"
FMDJ7-M-F

1 MECHANICAL TUNED FIBERGLASS DJEMBES, SYNTHETIC HEAD

Perfect for outdoors, these light-weight instruments feature a mechanical tuning system with a synthetic head. The mechanical tuning allows for easy and quick tuning. These djembes are perfect for any outdoor conditions.

SIZES **M:** 10" diameter, 18" tall
L: 12" diameter, 24" tall

MATERIALS Premium fiberglass
Synthetic Head

FEATURES 100% synthetic are perfect for outdoor playing
Traditional Rim
Black powder coated hardware
Light-weight and durable construction

FINISHES **FMDJ1:** Pharaoh's Script
FMDJ2: Kenyan Quilt
FMDJ5: Natural Black
FMDJ6: Earth Brown
FMDJ7: Crimson Red

2

NEW! NEW!



Pharaoh's Script, 12" **FMDJ1-L-G** Pharaoh's Script, 10" **FMDJ1-M-G**
 Kenyan Quilt, 12" **FMDJ2-L-G** Kenyan Quilt, 10" **FMDJ2-M-G**



HAND SELECTED GOAT HEAD

NEW! NEW! NEW!



Natural Black, 12" **FMDJ5-L-G** Natural Black, 10" **FMDJ5-M-G**
 Earth Brown, 12" **FMDJ6-L-G** Earth Brown, 10" **FMDJ6-M-G**
 Crimson Red, 12" **FMDJ7-L-G** Crimson Red, 10" **FMDJ7-M-G**

2 MECHANICAL TUNED FIBERGLASS DJEMBE, GOAT HEAD

These light-weight instruments feature a mechanical tuning system with a goat head. The mechanical tuning allows for easy and quick tuning. The hand selected goat head produces warm fat bass and rich open tones.

SIZES **M:** 10" diameter, 18" tall
 L: 12" diameter, 24" tall

MATERIALS Premium fiberglass
 Hand selected goat head

FEATURES Goat heads for warm tones
 Traditional Rim
 Black powder coated hardware
 Light-weight and durable construction

FINISHES **FMDJ1:** Pharaoh's Script
 FMDJ2: Kenyan Quilt
 FMDJ5: Natural Black
 FMDJ6: Earth Brown
 FMDJ7: Crimson Red



MCR-BK

OUR CONGA RISERS CAN ALSO BE USED FOR DJEMBES (SEE PAGE 023)



PROFESSIONAL FIBERGLASS DJEMBES



**MOUNTING THE HEAD
WITH TOP QUALITY
PRE-STRETCHED HTP
NYLON ROPE.**

HOW WE MAKE IT

NEW!

NEW!



Phantom Black, 12"
PROFADJ1-L



Phantom Black, 10"
PROFADJ1-M

PROFESSIONAL FIBERGLASS DJEMBES

The MEINL Professional Fiberglass Djembes come in a special designed shape. Equipped with synthetic head, this the perfect drum for outdoor gigs. These drums feature a lip positioned on the base to prevent the ring from slipping – this also helps to keep the djembe in tune for longer.

SIZES **M:** 10" diameter, 20" tall
L: 12" diameter, 24" tall

HTP ROPES **M:** 4 mm thickness, 25 runners
L: 5 mm thickness, 30 runners

MATERIALS Premium fiberglass
Synthetic head

FEATURES 100% synthetic are perfect for outdoor playing
Lightweight fiberglass construction
Pre-stretched HTP nylon ropes

COLOUR Phantom Black, matte



SYNTHETIC HEAD

HEADLINER® SERIES DANCING PERCUSSION

DJEMBES



YOEL PAEZ, SPAIN

1



Red, 8" x 11 1/4"
HFDD2R

2



Red, 8" x 11 1/3"
HDJ200R

3



Black, 8 1/2" x 24"
HC301BK

4



Red, 12" x 22 3/4"
HDJ400R

5



ADJUSTABLE STRAPS

MDJS1

The MEINL Headliner® Series Dancing Percussion are the perfect instruments for educational or street percussion. They are made from high quality materials and produce great sounds.

1 FIBERGLASS FAMILY DRUM

SIZE 8" diameter, 11 1/4" tall
MATERIAL Premium fiberglass
FEATURES Traditional rim
Black powder coated hardware
INCLUDES Nylon strap
Tuningkey
COLOUR **R:** Red

2 FIBERGLASS MINI DANCING DJEMBE

SIZE 8" diameter, 11 1/3" tall
MATERIAL Premium fiberglass

FEATURES Traditional rim
Black powder coated hardware
Floatune Tuning System
INCLUDES Nylon strap
Tuning key
COLOUR **R:** Red

3 FIBERGLASS DANCING CONGA

SIZE 8 1/2" diameter, 24" tall
MATERIAL Premium fiberglass
FEATURES 7 mm strong tuning lugs
2.2 mm rounded rim
Black powder coated hardware
INCLUDES Nylon strap
Tuning key
COLOUR **BK:** Black

4 FIBERGLASS DANCING DJEMBE

SIZE 12" diameter, 22 3/4" tall
MATERIAL Premium fiberglass
FEATURES 7 mm strong tuning lugs
2.2 mm rounded rim
Black powder coated hardware
INCLUDES Nylon strap
Tuning key
COLOUR **R:** Red

5 PROFESSIONAL DJEMBE STRAP

The MEINL Djembe Strap comfortably and securely holds any djembe in the perfect playing position.
MATERIAL Cloth-covered nylon
FEATURES Quick change hook
Adjustable straps
Quick-release buckles
COLOUR Multi colour



WOOD & FLOATUNE DJEMBES

1

NEW! NEW! NEW!



Vintage Wine Barrel, 12 1/2"
HDJ500VWB-M



Wine Red Burst, 12 1/2"
HDJ500WRB



Vintage Sunburst, 12 1/2"
HDJ500VSB



Natural, 12 1/2"
HDJ500NT

2



Blue Sparkle, 12"
DJF3BSP



SPARKLING EFFECT



Red Sparkle, 12"
DJF3RSP



SPARKLING EFFECT

3



Zebra Finished Ash, 12"
DJW3ZFA-M

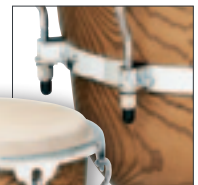

FLOATUNE TUNING SYSTEM

1 HEADLINER® SERIES WOOD DJEMBES

The MEINL Headliner® Series Djembes have it all! Equipped with hand selected goat heads, they produce the classic djembe sounds reaching from fat basses to rich open tones and cutting slaps.

SIZE 12 1/2" diameter, 25 1/4" tall

MATERIAL Rubber Wood
(*Hevea brasiliensis* Muell.-Arg.)

FEATURES 8 mm strong tuning lugs
2 mm rounded rims
Original MEINL style tuning brackets
Black powder coated hardware
Hand selected goat heads
Sleek Hourglass shape for more comfort

INCLUDES Tuning key

COLOURS **NT:** Natural, high gloss
VSB: Vintage Sunburst, high gloss
VWB-M: Vintage Wine Barrel, matte
WRB: Wine Red Burst, high gloss

2 FLOATUNE SERIES FIBERGLASS DJEMBES

The MEINL Floatune Series Fiberglass Djembes are truly a sound alternative. Fiberglass has enormous strength and can produce slaps of outstanding clarity and immensely powerful bass tones.

SIZE 12" diameter, 24 1/4" tall

MATERIAL Premium fiberglass

FEATURES True Skin Goat Heads
8 mm strong tuning lugs
3 mm rounded SSR-Rims
Easy tuning and comfortable change of heads
Rubber pads and lug placement offer perfect playing comfort
Floatune Tuning System
Chrome plated hardware

INCLUDES Accessory pouch
L-shaped tuning key
Tune Up Oil

COLOURS **BSP:** Blue Sparkle
RSP: Red Sparkle

4



Gold Amber Sunburst, 12 3/4"
DJW2GAB-M

Gold Amber Sunburst, 12"
DJW3GAB-M

REPOSITIONED TUNING LUGS
OFFER PERFECT PLAYING COMFORT



NEBOJSA JOVAN ZIVKOVIC, GERMANY

DJEMBES



Natural, 12 3/4"
DJW2NT

Natural, 12"
DJW3NT



African Brown, 12 3/4"
DJW2AB-M

African Brown, 12"
DJW3AB-M

FLOATUNE TUNING AVOIDS THE
NEED TO DRILL THROUGH THE SHELL

FLOATUNE SERIES WOOD DJEMBES ③ ④

The MEINL Floatune Djembes are modelled after the West African originals. Deep, round-sounding bass notes complimented by crisp tones and slaps are produced by this drum.

- FEATURES** True Skin Goat Heads
8 mm strong tuning lugs
3 mm rounded SSR-Rims
Easy tuning and comfortable change of heads
Rubber pads and lug placement offer perfect playing comfort
Floatune Tuning System
Chrome plated hardware
- INCLUDES** Accessory pouch
L-shaped tuning key
Tune Up Oil

- COLOURS** **AB-M:** African Brown, matte
GAB-M: Gold Amber Sunburst, matte
NT: Natural, high gloss
ZFA-M: Zebra Finished Ash, matte

③ FLOATUNE SERIES WOODCRAFT DJEMBE

- SIZE** 12" diameter, 24 1/4" tall
MATERIAL American White Ash
(*Fraxinus americana* L.)

④ FLOATUNE SERIES WOOD DJEMBES

- SIZES** **DJW2:** 12 3/4" diameter, 25 1/4" tall
DJW3: 12" diameter, 24 1/4" tall
MATERIAL Rubber Wood
(*Hevea brasiliensis* Muell.-Arg.)

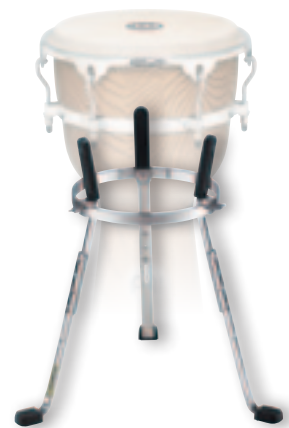

ST-DJEMBE

STEELY II DJEMBE STAND (SEE PAGE 168)



HOW WE MAKE IT

DARBUKAS DOUMBEKS

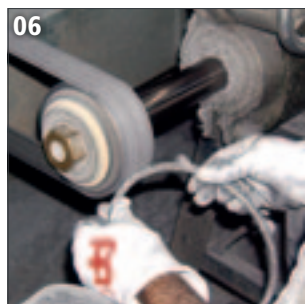

- 01** Aluminum is molten in a crucible, ready for casting.
- 02** These aluminum blanks will be spun into darbuka bodies.
- 03** Darbuka body is here spun-formed on a lathe.
- 04** Molten aluminum is cast into a form.
- 05** Cast aluminum bodies and rims.
- 06** Rim is getting finished after casting.
- 07** Some designs are hammered by hand.
- 08** Some designs are engraved by mechanical burin.



1



8" x 14 1/2"
HE-104



7 1/4" x 13 1/3"
HE-103



6 1/2" x 12 3/4"
HE-102



5 7/8" x 11"
HE-101



5 1/3" x 9 1/4"
HE-100

2

NEW! NEW! NEW!



8" x 14 1/2"
HE-114



7 1/4" x 13 1/3"
HE-113



6 1/2" x 12 3/4"
HE-112



5 7/8" x 11"
HE-111



5 1/3" x 9 1/4"
HE-110

DARBUKAS

MEINL darbukas are made in the tradition of the original, esoteric goblet-shaped drums found in music from Eastern Europe, the Middle East and Southern Asia. Our darbukas are constructed from thin shells in various metals, each metal giving the different models their special timbre. The head is secured and tuned with external rings set close to the shell, in the Turkish-style. Light yet powerful, the darbukas have a deep full bass. They are well suited for high-pitched snapping sounds as well as a wide range of articulated "dum" and "tak" strokes.

1 ALUMINUM DARBUKAS, PLAIN

SIZES **HE-100:** 5 1/3" x 9 1/4"
HE-101: 5 7/8" x 11"
HE-102: 6 1/2" x 12 3/4"
HE-103: 7 1/4" x 13 1/3"
HE-104: 8" x 14 1/2"

MATERIAL Aluminum
FEATURE Synthetic heads
INCLUDES Tuning key

2 ALUMINUM DARBUKAS, HAND-HAMMERED

SIZES **HE-110:** 5 1/3" x 9 1/4"
HE-111: 5 7/8" x 11"
HE-112: 6 1/2" x 12 3/4"
HE-113: 7 1/4" x 13 1/3"
HE-114: 8" x 14 1/2"

MATERIAL Aluminum
FEATURES Synthetic heads
Hand-hammered shells
INCLUDES Tuning key

3



BUILT IN JINGLES

8 1/4" x 16"
HE-315

8" x 14 1/2"
HE-314

4



HAND ENGRAVED SHELL

8" x 14 1/2"
HE-124

6 1/2" x 12 3/4"
HE-122

5



BRASS PLATED AND HAND-HAMMERED SHELL

7 7/8" x 15 1/2"
HE-215

7 1/2" x 14 3/4"
HE-214

6



HAND ENGRAVED SHELL

NATURAL RAWHIDE HEAD

7 7/8" x 15 1/2"
HE-205

7 1/2" x 14 3/4"
HE-204

3 ALUMINUM JINGLE DARBUKAS, HAND-HAMMERED

SIZES **HE-314:** 8" x 14 1/2"
HE-315: 8 1/4" x 16"

MATERIAL Aluminum

FEATURES Built in jingles
Synthetic heads
Hand-hammered shells

INCLUDES Tuning key

4 ALUMINUM DARBUKAS, HAND-ENGRAVED

SIZES **HE-122:** 6 1/2" x 12 3/4"
HE-124: 8" x 14 1/2"

MATERIAL Aluminum

FEATURES Synthetic heads
Hand engraved shells

INCLUDES Tuning key

5 COPPER DARBUKAS, BRASS PLATED, HAND-HAMMERED

SIZES **HE-214:** 7 1/2" x 14 3/4"
HE-215: 7 7/8" x 15 1/2"

MATERIAL Copper

FEATURES Synthetic heads
Hand-hammered shells

INCLUDES Carrying bag
Spare head
Tuning key

6 COPPER DARBUKAS, HAND ENGRAVED

SIZES **HE-204:** 7 1/2" x 14 3/4"
HE-205: 7 7/8" x 15 1/2"

MATERIAL Copper

FEATURES Natural rawhides
Hand engraved shells

INCLUDES Carrying bag
Spare head
Tuning key



1



PREMIUM FIBERGLASS



8 1/2" x 17 1/8"
FDB3000G

2



BLACK



COPPER

8 1/2" x 17 1/8"
HE-3000

8 1/2" x 17 1/8"
HE-3020



ELLEN MAYER, GERMANY

1 FIBERGLASS DOUMBEK

Our Fiberglass Doumbek has great sound properties and modern construction. Durable premium fiberglass shell bestows resonance and clarity. Crosshatched shell texture makes the doumbek easy to hold and resists slipping. Synthetic head holds tuning in all weather conditions.

SIZE 8 1/2" x 17 1/8"

MATERIAL Premium fiberglass

FEATURES Solid fiberglass construction
Synthetic head

COLOUR **G**: Gold

DOUMBEKS 2 3 4 5 6

SIZE 8 1/2" x 17 1/8"

INCLUDES Carrying bag, Spare head, Tuning key

2 ALUMINUM DOUMBEKS

Hand made entirely of aluminum, the MEINL Doumbek is outstanding in sound and quality, reaching from resonant lows to ringing highs. Available in two different finishes.

MATERIAL Aluminum

FEATURE Synthetic heads

COLOURS **HE-3000**: Black

HE-3020: Copper

3 ALUMINUM DOUMBEK, HAND ENGRAVED

This aluminum doumbek comes in a ornamental hand graving and produces snappy mid east sounds.

MATERIAL Aluminum

FEATURES Synthetic head
Hand engraved shell

4 ALUMINUM DOUMBEK, HAND-HAMMERED

The aluminum shell of this MEINL Doumbek is completely hand-hammered for a most appealing look.

MATERIAL Aluminum

FEATURES Synthetic head
Hand-hammered shell

3



HAND ENGRAVED SHELL

8 1/2" x 17 1/8"
HE-3018

4



HAND-HAMMERED SHELL

8 1/2" x 17 1/8"
HE-3030

5



WOOD COVERED SHELL

8 1/2" x 17 1/8"
HE-3400

6



HAND ENGRAVED SHELL

8 1/2" x 17 1/8"
HE-3012

PROFESSIONAL DOUMBEK STAND
(SEE PAGE 169)

TMID

5 ALUMINUM DOUMBEK, WOOD COVERED

The shell of this MEINL Doumbek is made from aluminum and is completely covered with a layer of the finest wood.

MATERIAL Aluminum

FEATURES Synthetic head
Wood covered shell

6 COPPER DOUMBEK, HAND ENGRAVED

The copper shell of this MEINL Doumbek is hand engraved for a stunning look. A very traditionally looking and sounding instrument.

MATERIAL Copper

FEATURES Synthetic head
Hand engraved shell



RÜDIGER MAUL, GERMANY



HOW WE MAKE IT

ARTISAN EDITION DOUMBEKS



01 Heating the inlays for the base design.

02 Gluing the inlays on the body.

03 Mother of Pearl is used to cover the aluminum shell.

04 Cutting Mother of Pearl in small pieces.

05 Preparing a special glue for the Mother of Pearl mosaic.

06 Applying the Mother of Pearl pieces on the drum.

07 Sanding the shell to make it smooth and shiny.

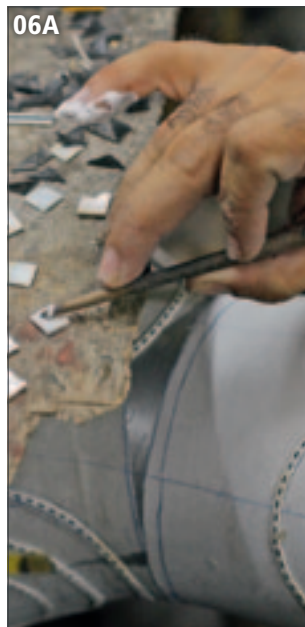

ARTISAN EDITION DOUMBEEKS

1

NEW!



Palace Mosaic, 8 3/4" x 17 1/2"
AE-ED5-1

2

NEW!



Mosaic Royale, 8 3/4" x 17 1/2"
AE-ED5-2

3

NEW!



9" x 18 1/2"
AE-ED-SB

4

NEW!



9" x 18 1/2"
AE-ED7



SUAT BORAZAN, TURKEY

ARTISAN EDITION DOUMBEEKS

The new Artisan Edition Doumbeks by Meinl are made in Egypt. The authentic mosaic artwork finish is created with mother of pearl inlays. The doumbek itself is cast of solid aluminum and has a quality heft and beautiful tone that serious players will love.

1 2 SAMAI LINE

- MATERIALS** Aluminum body
Mother of pearl
- SIZE** 8 3/4" x 17 1/2"
- WEIGHT** 4.7kg
- FEATURES** Well balanced shape
Authentic Egyptian mosaic inlays
Produces outstanding dums and taks (teks)
- INCLUDES** Nylon bag
Spare head
Tuning key

3 ARTIST SERIES (SUAT BORAZAN)

The MEINL team is happy to have teamed with Suat Borazan to produce a well balanced drum that produces deep dums and sharp taks (teks). This Artist Series Doumbek is a versatile drum that meets the demands and specifications of all professional doumbek players.

- MATERIALS** Aluminum body
Mother of pearl
- SIZE** 9" x 18 1/2"
- WEIGHT** 5.7kg
- FEATURES** Extra heavy for better control
Larger in diameter for more projection
Well balanced shape
Authentic Egyptian mosaic inlays
Produces outstanding dums and taks (teks)
- INCLUDES** Nylon bag
Spare head
Tuning key

4 EL ZAFFA LINE

- MATERIALS** Aluminum body
Mother of pearl
Wood inlays
- SIZE** 9" x 18 1/2"
- WEIGHT** 5.7kg
- FEATURES** Extra heavy for better control
Larger in diameter for more projection
Well balanced shape
Authentic Egyptian mosaic inlays
Produces outstanding dums and taks (teks)
- INCLUDES** Nylon bag
Spare head
Tuning key



TABLAS

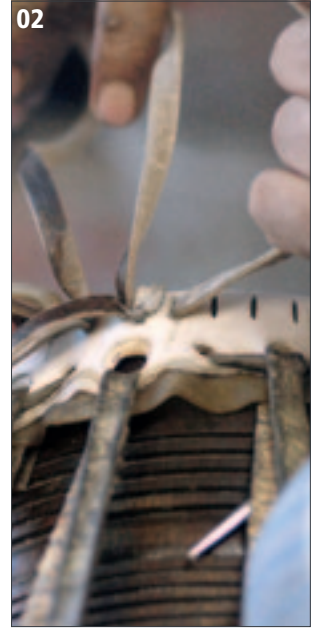

01 Preparing the head.

02 Mounting the head .

03 Preparing the syahi from different ingredients.

04 Making it look nice by using different kind of raw hides.

05 Putting the syahi on the dayan.

06 Cutting spare material of the damping layer.



ENGRAVING BEAUTIFUL ORNAMENTS ON THE BAYAN.

TABLAS



06

TABLAS

1



2



Bayan, 8 1/2" & Dayan, 5 1/2"
TABLA



Bayan, 9" & Dayan, 5 1/2"
PRO-TABLA

TOP-OF-THE-LINE PROFESSIONAL TABLA SET!
MADE BY A MASTER CRAFTSMAN IN INDIA

1 TABLA SET

The MEINL Tabla is made in the time-honored Indian tradition. Proper tuning is achieved by adjusting wooden rollers that are fitted under the nylon verticals.

SIZES Dayan 5 1/2"
Bayan 8 1/2"

MATERIALS Chrome plated copper with goat skin
Rosewood with goat skin

FEATURES Authentic tabla heads
Nylon straps for longer durability

INCLUDES Padded support rings
Tuning hammer

2 ARTISAN EDITION TABLAS

A top-of-the-line professional quality tabla set. Our Artisan Edition Tablas are made according to their classical heritage, and are superbly crafted. The tones are unsurpassed for their clarity and character. These are tablas that will make any player proud.

SIZES Dayan 5 1/2"
Bayan 9"

MATERIALS Copper with goat skin
Mahogany with goat skin

FEATURES Top quality goat skin tabla heads
Traditional tuning system with rawhide thongs

INCLUDES Tuning hammer and wooden tuning dowel
Ring pads
Protective head covers



MUTHU KUMAR, INDIA

1



Iya, 6 3/4"
BA3BK

Itotele, 5 3/4"
BA2BK

Okonkolo, 5 1/4"
BA1BK



ALFONSO GARRIDO, GERMANY

2



9" x 20"
ATD-XL

8" x 16"
ATD-L

7" x 12"
ATD-M



COMES WITH A CURVED WOODEN BEATER

3



BE1R



1 BATAS

The MEINL Batas are made from premium fiberglass for more durability, lighter weight and comfortable playing, and have a traditionally authentic sound.

SIZES Okonkolo 5 1/4" & 8",
Itotele 5 3/4" & 8 3/4"
Iya 6 3/4" & 12"

MATERIAL Premium fiberglass

FEATURES Hand selected buffalo heads
Traditional TTR-Rims

INCLUDES Nylon strap
Tuning key

COLOUR **BK**: Black

2 AFRICAN WOOD TALKING DRUMS

Our African Talking Drums are carved into an hour-glass shape from a solid piece of Mahogany wood, and decorated with a carved motif. Two hand-selected goatskin heads are spanned with high-quality nylon rope.

SIZES **M**: 7" x 12", 23 rope runners, 3 mm PP rope
L: 8" x 16", 28 rope runners, 3 mm PP rope
XL: 9" x 20", 34 rope runners, 3 mm PP rope

MATERIALS Mahogany Wood
Hand selected goat heads

FEATURES Carved from one solid piece of plantation grown Mahogany Wood
Nylon tuning strap

INCLUDES Curved wooden beater

FINISH Brown/Black

3 BERIMBAU

The thin striker and a caxixi are held in the right hand, while the left hand supports the bow and modulates the string with a small metal disc. The whole instrument is moved off-and-on the abdomen, opening and closing the resonant gourd, for a captivating "wah-wah" effect.

MATERIAL Premium fiberglass

INCLUDES Small Caxixi
Metal plate
Wooden stick
Carrying bag

COLOUR **R**: Red

1



Jumbo
SH2VSB

Medium
SH1BK

Medium
SH-R

NEARLY UNBREAKABLE

2



11"
MTA1SNT-M



TRUE SKIN BUFFALO HEADS

RITUAL DRUMS

3



8" & 9"
HCG89NT

HEAVY DUTY STAND CAN BE TILTED

4



7"
RAMWONG7

TRADITIONAL ROPE TUNING SYSTEM

1 SHEKERES

MEINL shekeres are handmade from premium fiberglass and fitted with a net of beads.

SIZES **SH-R**: Medium
SH1BK: Medium
SH2VSB: Jumbo
MATERIAL Premium fiberglass
COLOURS **BK**: Black
VSB: Vintage Sunburst
R: Red

2 TAMBORA

The rhythm of the Merengue has its roots in the Dominican Republic where the use of a Tambora drum is essential in creating this style of music.

SIZE 11"
MATERIAL Rubber Wood
(*Hevea brasiliensis* Muell.-Arg.)

FEATURES True Skin Buffalo Heads
Black powder coated hardware
INCLUDES Nylon strap
Wooden beaters
Tuning key
COLOUR **SNT-M**: Super Natural
FINISH Matte

3 WOOD CONGUITAS

The Conguitas complements the congas in a harmonically supportive sound spectrum.

SIZES 8" & 9"
MATERIAL Rubber Wood
(*Hevea brasiliensis* Muell.-Arg.)
FEATURES 8 mm strong tuning lugs
Original MEINL style tuning brackets
Traditional rims
Black powder coated hardware

INCLUDES Hand selected buffalo heads
Height adjustable tilting double braced tripod stand
Tuning key
Wrench
COLOUR **NT**: Natural
FINISH High gloss

4 RAMWONG

Ramwong is a Thai folk dance which evolved from Ramthone.

SIZE 7" diameter, 10" tall
MATERIAL Wood
FEATURES Natural rawhide
Traditional rope tuning system

1

NEW!



ID10WH



TMIH

IBO HOLDER (SEE PAGE 172)

2



ID2BKR

3



ID1BKR

BUILT IN MICROPHONE HOLE



LUIS RIBEIRO, AUSTRIA

1 QUINTO IBO DRUM

This ceramic Ibo Drum is small in size but big in sound. Perfect for unplugged gigs.

SIZE Small

MATERIAL Ceramic

FEATURES Full and rich sounds
Built in microphone hole

COLOUR **WH:** White

2 FIBERGLASS IBO DRUM, LONG NECK

The Fiberglass Ibo Drum with long neck has a wide variety of different sounds and is nearly unbreakable.

SIZE Long neck

MATERIAL Premium fiberglass

FEATURES Built in microphone hole
Resistant shell construction

INCLUDES Foam padded base

COLOUR **BKR:** Black/Red

3 FIBERGLASS IBO DRUM

This Ibo Drum has a wide variety of different sounds and the fiberglass body makes it nearly unbreakable.

SIZE Large

MATERIAL Premium fiberglass

FEATURES Built in microphone hole
Resistant shell construction

INCLUDES Foam padded base

COLOUR **BKR:** Black/Red

4 HEADED FIBERGLASS TRI SOUND IBO DRUM

This unique Ibo Drum features an additional rawhide playing surface and an extra thin bottom for enhanced sound.

SIZE Large

MATERIAL Premium fiberglass

FEATURES Rawhide playing surface
Built in microphone hole
Resistant shell construction

INCLUDES Foam padded base

COLOUR **GO:** Gold Ornament

5 FIBERGLASS TRI SOUND IBO DRUM

The regular Tri Sound Ibo Drum features an additional fiberglass playing surface and an extra thin bottom.

SIZE Large

MATERIAL Premium fiberglass

FEATURES Extra fiberglass playing surface
Built in microphone hole
Resistant shell construction

INCLUDES Foam padded base

COLOUR **BKO:** Black Ornament



4 RAWHIDE PLAYING SURFACE

ID3GO



5 EXTRA FIBERGLASS PLAYING SURFACE

ID4BKO



6 HAND CARVED BODY

ID6



ID7RB



8 EXTRA FIBERGLASS BOTTOM FOR MORE SOUND OPTIONS

ID8RB



9 THE FIBERGLASS LIQUID IBO DRUM IS FILLED WITH WATER

ID9BK/WH

6 WOOD IBO DRUM

The wooden body ensures a wide sonic range.

- SIZE Large
- MATERIAL Made from Mango Wood (*Mangifera* Sp.L.)
- FEATURES Dry tones
Built in microphone hole
- INCLUDES Foam padded base

7 CERAMIC IBO DRUM

The ceramic body of this Ibo Drum causes a slight enhancement of the higher frequencies, with fat and powerful bass tones.

- SIZE Large
- MATERIAL Ceramic
- FEATURES Full and rich sounds
Built in microphone hole
- INCLUDES Foam padded base
- COLOUR **RB:** Red/Brown

8 CERAMIC IBO DRUM, FIBERGLASS BOTTOM

The special feature of this MEINL Ceramic Ibo Drum is the fiberglass bottom for extra sound options.

- SIZE Large
- MATERIAL Ceramic
- FEATURES Fiberglass playing surface
Built in microphone hole
- INCLUDES Foam padded base
- COLOUR **RB:** Red/Brown

9 FIBERGLASS LIQUID IBO DRUM

A sealed metal chamber containing water is permanently bonded to the premium fiberglass body. The liquid chamber adds fluctuating overtones to the drum's fundamentals.

- SIZE Large
- MATERIAL Premium fiberglass
- FEATURES Special bottom, filled with water
Built-in microphone hole
Resistant shell construction
- INCLUDES Foam padded base
- COLOUR **BK/WH:** Black/White



HOW WE MAKE IT

CAJONS

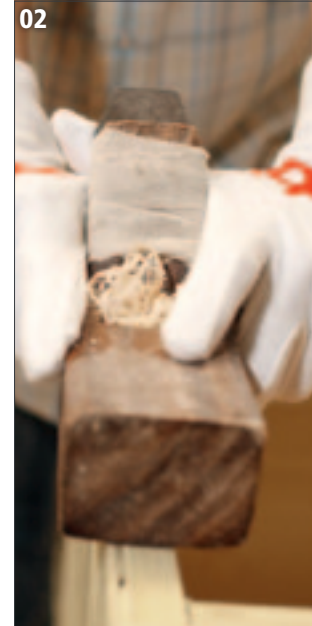

01 MEINL cajons are constructed with a combination of gluing and nailing techniques.

02 The cajon body is planed by hand. This creates the optimal contact between the faceplate and the body.

03 The sound hole is cut out of the back plate.

04 The sides and edges are carefully sanded.

05 The adjustable sizzle strings are positioned behind the frontplate. Here you see the tuning screws on the bottom of the cajon.

06 Our proprietary snare mechanism with foot pedal is being installed. Here you see the return spring being connected.

07 Here you see a Bubinga faceplate being fastened with screws.

08 MEINL cajons are securely packed for safe transport to distributors and dealers all over the world.

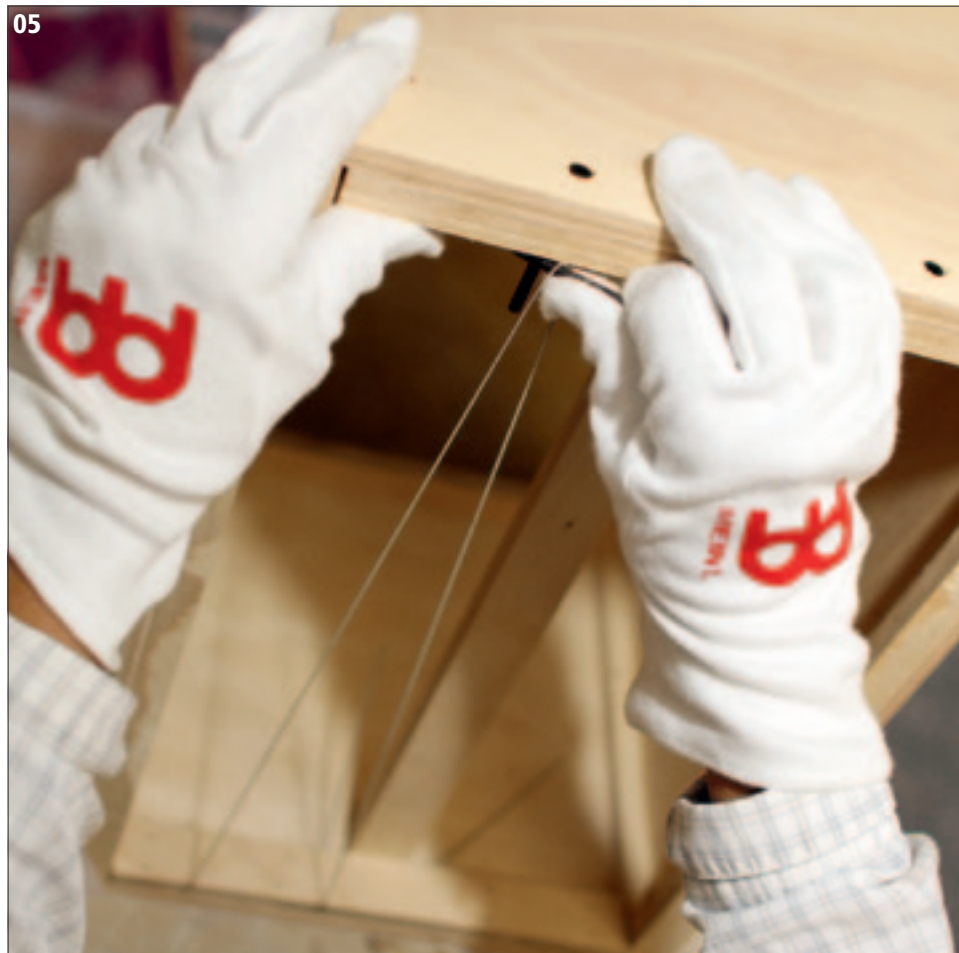



THE PARTS ARE MEASURED AND MARKED FOR DRILLING.



06



07

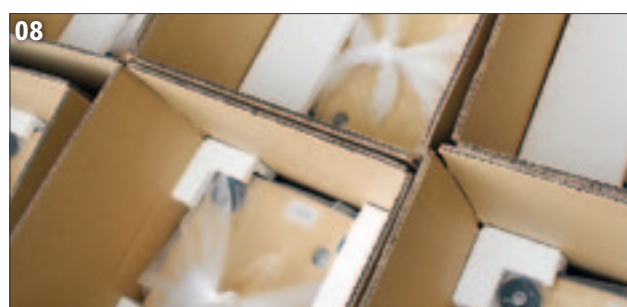

08

MEINL HEADLINER® SERIES CAJONS

1



Rubber Wood
HCAJ1NT



Rubber Wood
HCAJ3NT



Rubber Wood
HCAJ5NT



Mahogany
HCAJ1MH-M



Mahogany
HCAJ3MH-M



Mahogany
HCAJ5MH-M

NEW!

1 HEADLINER® SERIES CAJONS

The MEINL Headliner® Series Cajons deliver the classic cajon sound at an affordable price and can be used in Flamenco or World Music. They are also very useful during unplugged gigs for delivering the rhythmic foundation for a whole band when a full drum set can't be used.

SIZES **HCAJ1:** 11 3/4" W x 18" H x 11 3/4" D
HCAJ3: 11 3/4" W x 19 3/4" H x 11 3/4" D
HCAJ5: 13 1/4" W x 19 3/4" H x 13 3/4" D

MATERIALS **HCAJ1AWA / HCAJ3AWA / HCAJ5AWA**
Frontplate: Stained American White Ash (*Fraxinus Americana* L.)
Resonating body: Eco-friendly medium density fiberboard

FEATURES **HCAJ1MH-M / HCAJ3MH-M / HCAJ5MH-M**
Frontplate: Mahogany
Resonating body: Rubber Wood (*Hevea brasiliensis* Muell.-Arg.)
HCAJ1NT / HCAJ3NT / HCAJ5NT
Frontplate: Rubber Wood (*Hevea brasiliensis* Muell.-Arg.)
Resonating body: Rubber Wood (*Hevea brasiliensis* Muell.-Arg.)

INCLUDES Allen wrench
FINISH Matte



ADJUSTABLE SIZZLE EFFECT



ANTI-SLIP SITTING SURFACE



2 CAJON PAD
 The MEINL Cajon Pad is the optimal cushion for our Headliner® Series Cajons. It assures more comfort and a safe seat while playing the instrument.
 SIZE 10" x 10"
 MATERIAL Soft foam

2



CAJ-PAD



1



Makah-Burl
CAJ3MB-M



Black Makah-Burl
CAJ3BMB-M



Premium fiberglass
CAJ7NT-BK



American White Ash
CAJ3AWA

ADJUSTABLE TOP CORNERS



JOANNIE LABELLE, CANADA

1 STRING CAJONS (US PATENT)

MEINL Cajons feature a built in adjustable sizzle effect. Strings, which touch the frontplate on the inside and span from top to bottom, deliver a sensitive rattle that can be adjusted to fit various musical applications. The patented integrated string mute system controls the tension of the strings and ensures a dry and crisp sizzle effect.

MATERIALS Resonating body: Rubber Wood (*Hevea brasiliensis* Muell.-Arg.),

CAJ3MB-M

Frontplate: Makah-Burl

CAJ3BMB-M

Frontplate: Black Makah-Burl

CAJ7NT-BK

Frontplate: Premium fiberglass

FEATURES

CAJ3AWA

Resonating body: PVC covered eco-friendly medium density fiberboard

Frontplate: American White Ash (*Fraxinus Americana* L.)

Adjustable top corners

Adjustable sizzle effect

Integrated string mute system (US patent)

Wide sound options

Padded sitting surface

Includes Allen wrench

INCLUDES

FINISH

Matte



ADJUSTABLE SIZZLE EFFECT WITH
INTEGRATED STRING MUTE SYSTEM
(US PATENT)

2



Bundle with MSTCJB
CAJ3MB-M+BAG



Bundle with MSTCJB
CAJ3BMB-M+BAG



Bundle with MSTCJB
CAJ7NT-BK+BAG

BUNDLED WITH BAG

CAJONS

3



TMCAJ

PROFESSIONAL CAJON STAND (SEE PAGE 168)



Bubinga
CAJ300BU-M



ERGO-SHAPE (PATENTED)

2 STRING CAJONS BUNDLE WITH BAG (US PATENT)

3 ERGO-SHAPE STRING CAJON (PATENTED)

The MEINL Ergo-Shape String Cajon features an exotic Bubinga frontplate and two innovations: The frontplate is ergonomically curved for maximum comfort and sound development, and the string mute system gives your sound extra precision and control. The Bubinga frontplate is a rich and beautiful reddish coloured African wood.

MATERIALS Frontplate: Bubinga
Resonating Body: Rubber Wood
(*Hevea brasiliensis* Muell.-Arg.)

- FEATURES** Ergo-Shape (DE, US patent)
Adjustable sizzle effect
Integrated string mute system (US patent)
Adjustable top corners
Padded sitting surface
- INCLUDES** Allen wrench
- FINISH** Matte



ALEX PERTOUT, AUSTRALIA



SNARE, COLLECTION & TURBO CAJONS



American White Ash
CAJ1SNT-M

Ebony
CAJ1EB-M

Premium fiberglass
CAJ1CA-M



Cherry
CAJ2RO-M

Red Oak
CAJ4RO-M

INVENTOR:
OLIVER BÖTTGER

1 SNARE CAJONS

The snares touch the frontplate from the inside and deliver the classical cajon sound, which is requisite in Flamenco music. A knurled knob adjusts the amount of pressure used to press the snare wires against the frontplate.

MATERIALS CAJ1CA-M

Frontplate: Premium fiberglass
Resonating body: Rubber Wood (*Hevea brasiliensis* Muell.-Arg.)
CAJ1EB-M
Frontplate: Ebony
Resonating body: Rubber Wood (*Hevea brasiliensis* Muell.-Arg.)
CAJ1SNT-M
Frontplate: American White Ash (*Fraxinus americana* L.)

FEATURES

Adjustable top corners
Internal, adjustable snare wires
Padded sitting surface
Wide sound options
FINISH Matte

2 COLLECTION CAJON

The MEINL Collection Cajon features elegant veneers, both for the frontplate, and for the resonating body.

MATERIALS

Frontplate: Cherry
Resonating body: Red Oak (*Quercus rubra*)

FEATURES

Adjustable top corners
Internal, adjustable snare wires
Padded sitting surface

FINISH

Matte

3 TURBO CAJON (US PATENT)

Our Turbo Cajon goes an extra step towards cutting edge. We made this cajon with upper corners that have deeply cut channels with castanet-like striking surfaces.

MATERIAL

Frontplate and resonating Body:

Red Oak (*Quercus rubra*)

FEATURES

Castanet-like striking surface (US patent)
Internal snare wires
Wide sound options
Padded sitting surface

FINISH

Matte

PEDAL & PICKUP CAJONS

1



Bubinga
CAJ100BU-M

2

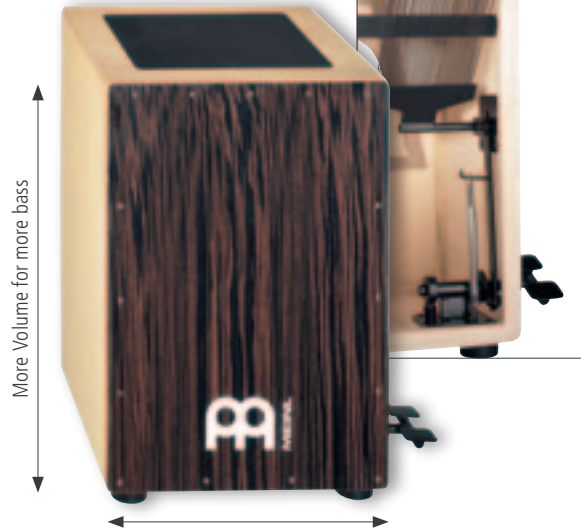

Ebony
CAJ5EB-M

FOOT PEDAL FOR A QUICK ON/OFF SWITCH OF THE SNARE WIRES (US PATENT)

More Volume for more bass

3



RAÚL MALDONADO, PUERTO RICO



American White Ash
CAJ9SNT-M



Makah-Burl
CAJ8MB-M

ACTIVE PRE-AMP SYSTEM WITH VOLUME CONTROL FROM Shadow®

PEDAL CAJONS 1 2

A pedal attached to the cajon adjusts the amount of pressure used to press the snare wires against the front plate, and can even be turned off completely.

MATERIAL Resonating Body: Rubber Wood (*Hevea brasiliensis* Muell.-Arg.)

FEATURES Foot pedal (US patent)
Internal adjustable snare wires
Adjustable top corners
Padded sitting surface

FINISH Matte

1 ERGO-SHAPE PEDAL CAJON (PATENTED)

MATERIAL Frontplate: Bubinga
FEATURES Ergo-Shape (DE, US patent)
Foot pedal (US patent)

2 BASS PEDAL CAJON (US PATENT)

MATERIAL Frontplate: Ebony

FEATURES Great bass tones
Wide sound options
Foot pedal (US patent)

3 PICKUP CAJONS

The MEINL Pickup Cajons are equipped with a pickup microphone and a pre-amp system with volume control from Shadow®. This active system includes a specially designed pre-amp, high quality endpin output jack and a durable battery.

MATERIALS Resonating body: Rubber Wood (*Hevea brasiliensis* Muell.-Arg.)
CAJ9SNT-M
Frontplate: American White Ash (*Fraxinus americana* L.)

CAJ8MB-M

Frontplate: Makah-Burl

FEATURES Pickup microphone
Active pre-amp system with volume control from Shadow®
Adjustable top corners
Padded sitting surface
Wide sound options

CAJ9SNT-M

Internal, adjustable snare wires

CAJ8MB-M

Adjustable sizzle effect with integrated string mute system (US patent)

INCLUDES 9-volt battery

CAJ8MB-M

Allen wrench

FINISH Matte



HOW WE MAKE IT

ARTISAN EDITION PERUVIAN CAJONS

Made in 



01 Selecting top quality Peruvian Cedar boards.

02 The cajon features dovetail joints, which are the strongest possible in cabinet joinery.

03 The cajon body is inspected to make sure it meets MEINL's high quality standards. The angles are measured to a precise 90 degrees.

04 Carefully measuring and marking the position for the sound hole.

05 The cajon body is planed by hand.

ARTISAN EDITION PERUVIAN CAJONS



HISTORY The first African inhabitants arrived in America with little belongings. They were deprived of everything, including drums, one of their main instruments of expression. The ancient Afro-Americans found their way to obtain new percussion instruments, some of them did it by imitating the instruments left in Africa, and others did it by just creating new ones. During the drum playing prohibition boxes, made to transport merchandise or products, appeared and the authorities thought these boxes were not drums but homemade instruments so they didn't really care about it. Nevertheless, those rustic boxes started little by little to be used to accompany music and they were called "cajones" or "cajas" (boxes).

In Peru today, the cajon is present in almost all kinds of Afro-rooted music (lundero, lando, festejo, alcatraz, toromata, panalivio, inga, etc.), and also accompanies the Peruvian waltz, the Creole polka, the one step, the pasodoble, the tondero and the marinera. Likewise, the cajon has been adopted by many others around the world that are using it for the interpretation of their own music or for recreational purposes.



Reference: Rafael Santa Cruz

1

NEW!



Matte
AE-PCAJ1

NO SNARES, NO STRINGS – ONLY PURE WOODEN CAJON SOUND. ORIGINAL PERUVIAN STYLE!

2

NEW!



High Gloss
AE-PCAJ2

AUTHENTIC PERUVIAN CAJONS MADE IN PERU

ARTISAN EDITION PERUVIAN CAJONS 1 2

The MEINL Artisan Edition Peruvian Cajons are hand-made in Perú, where the cajon originated. These beautiful instruments offer truly authentic cajon sound to satisfy the most traditional and demanding players. Dovetail joinery construction allows for beautiful traditional cajon looks. For a crisp modern sound with pronounced bass and cutting slap select our AE-PCAJ1 matte finished model. For the most traditional cajon sound with earthy lows and subdued highs select our AE-PCAJ2 gloss finished model.

1 FESTEJO LINE, MATTE

MATERIAL 100% Authentic Peruvian Cedar (*Cedrela odorata*)

1-ply solid body

FEATURES Dovetail joinery construction
Matte finish for a crisp modern sound with pronounced bass and cutting slap
Thick resonating body and thin front plate
Specially formulated rubber feet
The heat-branded logo adds to the mystique

FINISH Matte

2 FESTEJO LINE, HIGH GLOSS

MATERIAL 100% Authentic Peruvian Cedar (*Cedrela odorata*)

1-ply solid body

FEATURES Dovetail joinery construction
Gloss finish for earthy lows and subdued highs
Thick resonating body and thin front plate
Specially formulated rubber feet
The heat-branded logo adds to the mystique

FINISH High Gloss



ARTISAN EDITION FLAMENCO CAJONS



HOW WE MAKE IT

EACH ARTISAN EDITION FLAMENCO CAJON IS BRANDED WITH A HOT IRON PRESS.

1



SPECIAL HAMMER TONE FINISH FOR BETTER FEEL AND GRIP

Soleá Line, Espresso Burst
AE-CAJ3

NEW!

2



Soleá Line, Ebony Burst
AE-CAJ3BK



Bulería Line, Lava-Burl
AE-CAJ5

UNCOMPROMISING CRAFTSMANSHIP

ARTISAN EDITION FLAMENCO CAJONS

1 2 3 4

MEINL Artisan Edition Flamenco Cajons are hand made in Spain with uncompromising craftsmanship for the most discerning of players. They are the finest cajons available on the market.

1 SOLEÁ LINE

MATERIALS **AE-CAJ3**

Frontplate: Espresso Burst
Resonating body: 9 layer Birch Wood
(*Betula pendula*)

AE-CAJ3BK

Frontplate: Ebony Burst
Resonating body: 9 layer Birch Wood
(*Betula pendula*)

FEATURES 10 pre-tuned upright strings
Ergonomically rounded frontplate with convex contact
Specially formulated rubber feet
Internal Bass Filter for sound compression
Distinguished heat branding

FINISH Satin

2 BULERÍA LINE

MATERIALS Frontplate: Lava-Burl

Resonating body: 9 layer of Birch Wood
(*Betula pendula*)

FEATURES Double 5-string tuneable snare arrays
Ergonomically rounded frontplate with convex contact
Specially formulated rubber feet
Internal Bass Filter for sound compression
Distinguished heat branding

INCLUDES Tuning key

FINISH Satin





SNARE WIRES ARE HAMMERED INTO GROOVES CUT INTO THE CAJON BODY.

3

NEW!



Cantina Line, Walnut
AE-CAJ6

FULL BASS SPECTRUM DUE TO BIGGER SIZE

4



Seguiriya Line, Canyon-Burl
AE-CAJ7

ERGONOMICALLY CURVED AND ROUNDED FRONTPLATE WITH CONCAVE CONTACT

NEW!



Seguiriya Line, Palo Santo
AE-CAJ7PS

3 CANTINA LINE

- MATERIALS** Frontplate: Walnut
Resonating body: 9 layer Birch Wood (*Betula pendula*)
- FEATURES** 16 vertical strings
Strings are adjustable from the top
Ergonomically rounded frontplate with convex contact
Specially formulated rubber feet
Full bass spectrum due to bigger size
Angeled playing surface
Distinguished heat branding
- INCLUDES** Tuning key
- FINISH** Satin

4 SEGURIYA LINE

- MATERIALS** **AE-CAJ7**
Frontplate: Canyon-Burl
Resonating body: 11 layer Birch Wood (*Betula pendula*)
- AE-CAJ7PS**
Frontplate: Palo Santo
Resonating body: 11 layer Birch Wood (*Betula pendula*)
- FEATURES** 16 adjustable, vertical strings
Ergonomically curved and rounded frontplate with concave contact
Specially formulated soft rubber feet
Extra sound port ring for compression
Decorative wood inlay
Distinguished heat branding
- INCLUDES** Tuning key
- FINISH** Satin



JUAN CARLOS MELIAN, SPAIN

1

SUPER LOW FREQUENCY



MICHAEL BUCHNER: INVENTOR OF PROFESSIONAL BONGO CAJON, SLAP-TOP CAJON AND SUBWOOFER CAJON

American White Ash
SUBCAJ1AWA

2



INVENTOR: AREND SCHMIDT-LANDMEIER

Ebony
TRECAJ2EB-M

ANGLED FRONTPLATE FOR MORE PLAYING COMFORT

3



Makah-Burl
TOPCAJ1MB



COMFORT DESIGN FOR A MORE UPRIGHT PLAYING STYLE (PATENT PENDING)

1 SUBWOOFER CAJON

The MEINL Subwoofer Cajon features a forward projecting sound port in place of the traditional rear facing style and an internal reflex channel. This results in an enhanced bass note projection, particularly desirable for live and unplugged situations.

MATERIALS Resonating body: Eco-friendly medium density fibreboard
Frontplate: American White Ash (*Fraxinus Americana* L.)

FEATURES Super low frequency
Forward projecting sound port
Internal snare wires
Adjustable top corners

FINISH Matte

2 TREJON

The Trejon is similar to a drum set in that bass, snare, and tom sounds are in easy reach on the comfortably angled playing surface.

MATERIALS Frontplate: Ebony
Resonating Body: Rubber Wood (*Hevea brasiliensis* Muell.-Arg.)

FEATURES Angled playing surface
Two internal snare wires
Adjustable top corners
Padded sitting surface

3 SLAP-TOP CAJON (PATENT PENDING)

The MEINL Slap-Top Cajon is a conceptual step up to a new level. This model is designed to bring the striking surface up nearer to the player, for a more upright playing style. The sound projects forward into the audience! High and low tones as well as a snare effect are built in to the sound board.

MATERIALS Resonating body: Eco-friendly medium density fibreboard
Frontplate: Makah-Burl

FEATURES Comfortable design
Forward sound projection
Internal snare wires
Wide sound spectrum



Natural/Ebony Black, 7" & 8 1/2"
PBCA1NT/EBK-M

FORWARD
SOUND PROJECTION



Natural/Ebony Black
BCA2NT/EBK-M

Super Natural
BCA1SNT-M

INTERNAL
SNARE WIRES

TWO DIFFERENT SIZED CHAMBERS
ENABLE AN AUTHENTIC BONGO EFFECT



Makah-Burl
PLCA1MB-M

ADJUSTABLE SIZZLE EFFECT



Natural
CCA1NT



Brown
MARIMBULA

NEW!

4 PROFESSIONAL BONGO CAJON (DE PATENT)
5 BONGO CAJONS

The MEINL Snare Bongo Cajon can be played like a bongo, between the legs, or on one's lap. The professional version has a forward sound projection.

MATERIAL Rubber Wood
(*Hevea brasiliensis* Muell.-Arg.)

FEATURES High- and low pitch playing surface
Compact size and light weight
BCA2NT/EBK-M: Internal snare wires
PBCA1NT/EBK-M: (DE patent)
High and low striking surfaces
Forward sound projection
Comfortable design

COLOURS **NT/EBK-M:** Natural/Ebony Black
SNT-M: Super Natural

6 PALITO

Strings which touch the playing surface on the inside deliver a sensitive sizzle effect that fits to various musical applications.

MATERIALS Playing surface: Makah-Burl
Resonating body: Rubber Wood
(*Hevea brasiliensis* Muell.-Arg.)

FEATURES Adjustable sizzle effect
Compact size

INCLUDES Allen wrench

7 CAJITA

The MEINL Cajita is developed from the classic Peruvian folk instrument. It hangs from the neck and is played with a wooden striker in one hand. The other hand controls the handle on the lid.

MATERIAL Rubber Wood
(*Hevea brasiliensis* Muell.-Arg.)

FEATURES Soft nylon cord
Solid piano hinge
Easy-grip handle

INCLUDES Wooden striker

8 MARIMBULA

The body of this Caribbean instrument is made out of Rubber Wood and has eight tongues in front of it. The Marimbula can also be played with soft mallets.

MATERIALS Rubber Wood
(*Hevea brasiliensis* Muell.-Arg.)
Steel tongues

FEATURES Tuning: f c G D F A d g
Solid construction
Heavy duty rubber feet for a solid base

COLOUR Brown
FINISH Matte



MAKE YOUR OWN CAJON

NEW!



ASSEMBLY INSTRUCTION COMES IN SEVEN LANGUAGES

Baltic Birch
MYO-CAJ

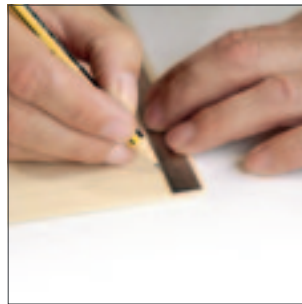
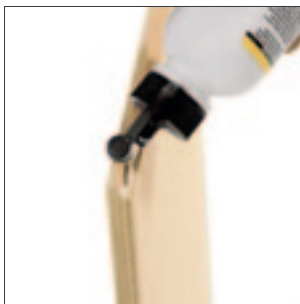

MAKE YOUR OWN CAJON

One of the most popular percussion instruments today is the Cajon and now with the new MEINL Cajon Kit you can build your own. The kit comes with all the parts and a list of the materials and tools you need. The instructions will guide you through this fun project and at the end you will be able to customize the finish of the instrument by adding oil, a lacquer, wax, or paint it with an entirely unique design.

SIZE 11 3/4" W x 18" H x 11 3/4" D

MATERIALS Baltic Birch (*Betula*)
Steel snare wires

DELIVERY INCLUDES

- 1 x assembly instructions in seven languages
- 2 x side panels
- 1 x base panel
- 1 x top panel
- 1 x rear panel
- 1 x playing surface (with MEINL logo)
- 2 x side battens
- 1 x base & 1 x top batten
- 1 x securing batten for the snare
- 1 x snare
- 4 x rubber feet
- 15 x screws 3 x 20 mm (for playing surface)
- 4 x screws 4 x 15 mm (for rubber feet)
- 2 x screws 3 x 12 mm (for snare)

COLOUR Natural

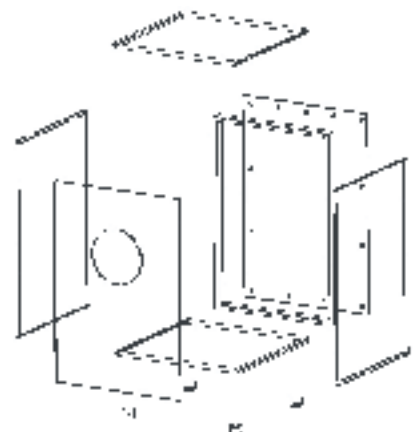

MAKE YOUR OWN BONGO CAJON

NEW!



CAJONS

Baltic Birch
MYO-BCAJ

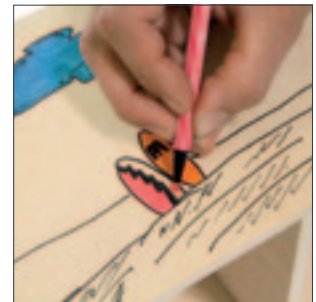

MAKE YOUR OWN BONGO CAJON

A very popular item from the MEINL ultimate selection of instruments is the Bongo Cajon and now you can build your own with this construction kit. The kit comes with all the parts and a list of the materials and tools you need. The instructions will guide you through this fun project and at the end you will be able to customize the finish of the instrument by adding oil, a lacquer, wax, or paint it with an entirely unique design.

SIZE 15 3/4" W x 7 1/4" D x 6 3/4" H

MATERIAL Baltic Birch (*Betula*)

DELIVERY INCLUDES

- 1 x assembly instructions in seven languages
- 2 x side panels, long
- 2 x side panels, short
- 1 x playing surface (with MEINL logo)
- 1 x sound chamber partition

COLOUR Natural

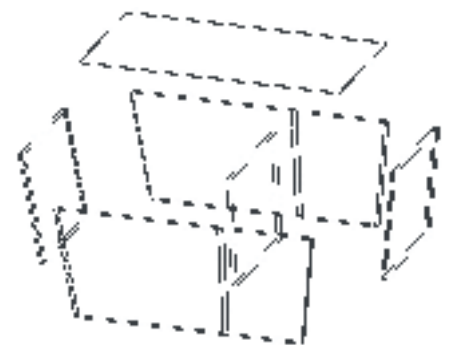



FOOT PERCUSSION



HOLGER MERTIN, GERMANY

SOUNDS

- 0 - Kick Bass
- 1 - Cyber Kick
- 2 - Tribal Bass
- 3 - Straight Tambourine
- 4 - Double Tambourine
- 5 - Clave
- 6 - Hand Clap
- 7 - Dry Cowbell
- 8 - Straight Cabasa
- 9 - Double Cabasa



10 sound options
FX10



A WHOLE PERCUSSION KIT IN A BOX
FRONT VIEW



INVENTOR: TORSTEN FRANZ

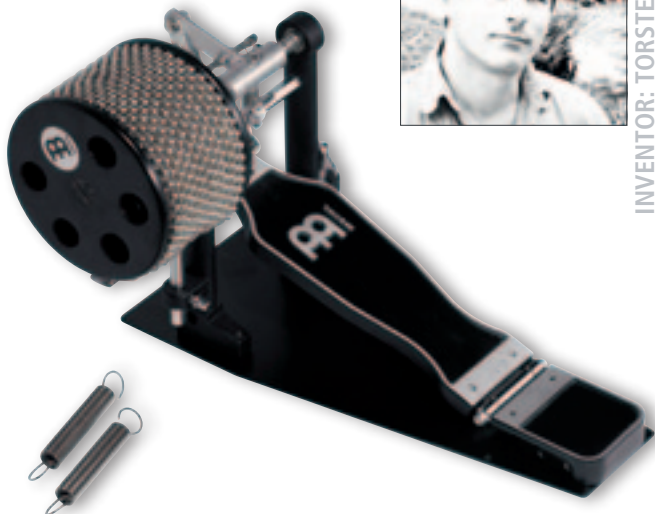

Additional springs with more tension
SPARE-20

Large
FCA5-L

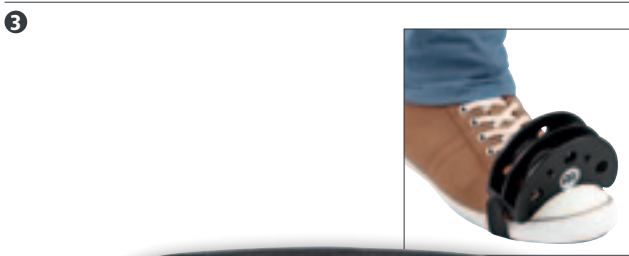

Stainless steel
FJS2S-BK

1 FX PEDAL

The MEINL FX Pedal features 10 different sound options that you can add to your beat. Cycle through the effects with a touch of the toe button. It's a whole percussion kit in a box! Plug in and groove...

MATERIALS Oak (*Quercus (robur) pedunculata*) and steel box

FEATURES Microprocessor controls
10 different sound options
Sound select button
Stereo/Mono output
Made in Germany by Shadow

INCLUDES Hook and loop fastener with spikes
International power converter

2 FOOT CABASA (US PATENT)

The MEINL Foot Cabasa is a breakthrough instrument for the percussionist! We mounted a large Turbo Cabasa on our sturdy foot pedal (US patent), which adds a new sound to your setup. Keep a cabasa rhythm while your hands play the congas or other drums! The MEINL Foot Cabasa can be set for either a single or double-stroke, according to your taste.

SIZE Large
MATERIALS Steel chain and stainless steel cylinder
Wooden body
Black powder coated pedal

FEATURES Optional single or double-stroke setting
5 sound ports on each side for more volume (CN, DE, US patent)

INCLUDES Drum key
Foot pedal

3 FOOT TAMBOURINE

The Foot Tambourine is a perfect compliment for virtually any instrument. It's light and versatile, yet not overpowering, delivering a sensitive accompaniment. Easily mounted on your foot, it will go with any beat.

MATERIAL Rubber Wood
(*Hevea brasiliensis* Muell.-Arg.)

FEATURES Bright, light accent for any instrument
Ergonomic design
Hassle-free mounting
Stainless steel jingles

COLOUR **BK**: Black

CAJON ADD-ONS

1



INVENTOR: MICHAEL BUCHNER



ADD NEW SOUNDS TO YOUR CAJON

CAJON ADD-ONS

Black
WSS1BK

2



Small
WC1-S

Medium
WC1-M

Large
WC1-L

3



Medium
WJC1-M

1 WOOD SIDE SNARE

The Wood Side Snare for cajons takes your sound up to another level. Self-adhesive tape securely holds the ergonomically shaped box to any side of the Cajon. The player decides the perfect spot. It can be removed as desired.

MATERIAL Rubber Wood
(*Hevea brasiliensis* Muell.-Arg.)

FEATURES Internal snare effect
Hook and loop fastener attaches to Cajon body
Ergonomic shape
Unobtrusive low profile

COLOUR **BK**: Black

FINISH Matte

2 CAJON CASTANETS

Our lightweight Castanets come in three sizes, and with hook and loop fastener. Stick them anywhere to add new colours to your cajon or any other instrument!

SIZES Small
Medium
Large

MATERIAL Rubber Wood
(*Hevea brasiliensis* Muell.-Arg.)

FEATURES Spring-opened
Hook and loop fastener goes on any surface

COLOUR Black

FINISH Matte

3 CAJON JINGLE CASTANET

The MEINL Cajon Jingle Castanet adds another accent to the Cajon. A pair of steel jingles gives a light metallic touch to the fundamental wooden Castanet. Various finger techniques produce changeable sounds. Like all our Cajon Castanets, self-adhesive tape application means they go easily on your cajon, or anywhere else.

SIZE Medium

MATERIAL Rubber Wood
(*Hevea brasiliensis* Muell.-Arg.)

FEATURES Spring-opened
Hook and loop fastener goes on any surface
Steel Jingles

COLOUR Black

FINISH Matte



CAJON ADD-ONS

1 IMPROVED!



Black
TCAJ1BK

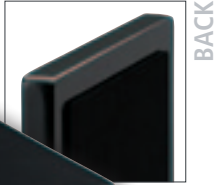

BACK

2

NEW!



Black
CAJ-BLK

EXTRA POCKET FOR SMALL PERCUSSION

3

NEW!



Medium
JT-S-BK

4

NEW!



Large
CSM-L

NEW!



Medium
CSM-M

DESIGNED TO HOLD OUR CAJON ADD-ONS
CLOSE TO THE PLAYING SURFACE



1 TRAVEL CAJON

The MEINL Travel Cajon is a great way to practice cajon techniques while on the go or when you need to keep the volume way down. It is perfect for keeping your chops in shape, any time, anywhere!

SIZE 11 3/4"

MATERIAL Rubber Wood
(*Hevea brasiliensis* Muell.-Arg.)

FEATURES Internal snare wires
Compact design
Sound port for clear sound projection
Great way to practice cajon techniques while on the go

COLOUR **BK:** Black

FINISH Matte



2 CAJON BLANKET

The MEINL Cajon Blanket is an excellent addition to your cajon that will help you make good use of space. The blanket is attached with a string to the bottom of the cajon and features on top a padded sitting area for comfort. On one side the blanket has a pocket for extra percussion instruments storage while the other side is prepared with hook and loop fastener to allow the attachment of different cajon add-ons.

MATERIAL Heavy duty nylon

FEATURES Fits on any cajon
Hook and loop fastener to mount additional add-ons

Extra pocket for small percussion

COLOUR Black

3 JINGLE TAP

The MEINL Jingle Tap is part of the cajon add-ons that you can mount anywhere with hook and loop fastener to expand the possibilities on your set. The steel jingles will give a nice accent to almost any musical situation.

SIZE Medium

MATERIAL Rubber Wood
(*Hevea brasiliensis* Muell.-Arg.)

FEATURES Steel jingles
Hook and loop fastener goes on any surface

COLOUR **BK:** Black



NEW!

6

NEW!



STEEL JINGLES



INTERNAL SNARE WIRES

Black
KP-JT-BK

Black
KP-ST-BK

7

NEW!

NEW!



ERGONOMICALLY DESIGN



MICHAEL BUCHNER: INVENTOR OF JINGLE TAP, CAJON SIDE MOUNTS, KNEE PAD JINGLE AND SNARE TAP, FINGER JINGLES

Steel jingles
FJS1S-BK

Aluminum jingles
FJS1A-BK

4 CAJON SIDE MOUNTS

The MEINL Cajon Side Mounts were designed to hold our cajon add-ons close to the playing surface in order to offer you more musical possibilities. The mount comes in large and medium size and is easily placed by simple hook and loop fastener.

SIZES Medium
Large

MATERIAL Rubber Wood
(*Hevea brasiliensis* Muell.-Arg.)

FEATURES Easy handling
Hook and loop fastener goes on any surface
Offers better cajon accessory placement

COLOUR Black

5 KNEE PAD JINGLE TAP

The new MEINL Knee Pad Jingle Tap is another addition to the big collection of cajon add-ons. It comes with a strap that allows you to attach it to your leg for easy access when playing.

MATERIAL Rubber Wood
(*Hevea brasiliensis* Muell.-Arg.)

FEATURES Steel jingles
Strap with hook and loop fastener to mount on your leg

COLOUR **BK:** Black

6 KNEE PAD SNARE TAP

The MEINL Knee Pad Snare Tap will bring the snare sound to your set up. The strap helps you secure it to your leg and in minutes you are ready to play.

MATERIAL Rubber Wood
(*Hevea brasiliensis* Muell.-Arg.)

FEATURES Snare effect
Strap with hook and loop fastener to mount on your leg

COLOUR **BK:** Black

7 FINGER JINGLES

The MEINL finger jingles are small in size but big in sound by offering infinite possibilities to the percussion player without adding too much weight to the percussion bag. They are lightweight and ergonomically designed for comfort when playing.

MATERIALS **FJS1S:** Steel jingles
FJS1A: Aluminum jingles
Rubber Wood
(*Hevea brasiliensis* Muell.-Arg.)

FEATURES Ergonomically design
Comfortable handling

COLOUR **BK:** Black

MEINL HEADLINER® SERIES TIMBALES



Chrome, 13" & 14"
HT1314CH

HEADLINER® SERIES TIMBALES (PATENTED)

The MEINL Headliner® Series Timbales come in 13" and 14" sizes, are made from chrome plated steel, and come with a heavy-duty, height adjustable tilting stand. They provide the classic timbale sound and are the perfect introduction to the joy and passion of timbale playing at an affordable price.

SIZES 13" & 14"

MATERIAL Steel

FEATURE Logo applied from underneath the head (CN, US patent)

INCLUDES Height adjustable tilting double braced tripod stand
Tuning key
Wrench

Cowbell holder

FINISH Chrome

HOW WE MAKE IT

01 The first tack welds make it into a raw drum body.

02 Rollers form the body flanges, which are important for stability and a proper dry Cascara sound.

03 Here you see raw components for the Luis Conte Signature Timbales. The freshly cast mounting brackets will be cut free and individually polished. In the background, note the heavily hammered texture in the center portion of the shell stock.

04 The MEINL Luis Conte Signature Timbales have a hammered texture. This is applied before the body is rolled into shape.



YUVISNEY AGUILAR, SPAIN

MARATHON® SERIES TIMBALES

TIMBALES



Chrome, 14" & 15"
MT1415CH



Brass, 14" & 15"
MT1415B



HEAVY DUTY
STYLE BRACKETS

NEW!



FINISH INSPIRED BY
FREDDY MIRINDA



Black nickel, 14" & 15"
MT1415BN



Antique Finish, 14" & 15"
MT1415RR-M

MARATHON® SERIES TIMBALES (PATENTED)

MEINL Marathon® Series Timbales are professionally equipped yet are offered at an affordable price. They are perfect for the working percussionist or to be included in a drum setup.

SIZES 14" & 15"

MATERIAL Steel

FEATURES Two worked in flanges
Heavy duty style brackets
Logo applied from underneath the head
(CN, US patent)

INCLUDES Adjustable cowbell holder
Height adjustable tilting double braced tripod stand
Accessory pouch
L-shaped tuning key
Tune Up Oil

FINISHES **B:** Brass
BN: Black nickel
CH: Chrome
RR-M: Antique Finish, matte



JIMMY BRANLY, USA



FLOATUNE, ARTIST & TURBO TIMBALES

1



BLACK POWDER COATING FOR DRY AND CUTTING SOUNDS

Black, 13" & 14"
TI1BK

2



AMADITO VALDÈS, CUBA

Black, 14" & 15"
AV1BK

Amadito Valdès

3



EXTRA DEEP SHELLS FOR SUPER PROJECTION AND GREAT BASS TONES

Black, 14" & 15"
MTT1415BK

FLOATUNE SERIES TIMBALES 1 2

MATERIAL Black powder coated steel

FEATURES Two worked in flanges
Floatune Tuning System
Logo applied from underneath the head (CN, US patent)

INCLUDES Adjustable cowbell holder
Height adjustable tilting double braced tripod stand
Accessory pouch
L-shaped tuning key
Tune Up Oil

COLOUR Black

1 FLOATUNE SERIES (PATENTED)

The MEINL Floatune Tuning System used on these timbales works without having to drill into the shell.

SIZES 13" & 14"

2 ARTIST SERIES TIMBALES (AMADITO VALDÈS) (PATENTED)

Our Artist Series Amadito Valdès Timbales – a tribute to one of the greatest timbaleros ever. Featuring our Floatune Tuning System and produce a dry and cutting sound due to the black powder coated shells.

SIZES 14" & 15"

3 MARATHON® SERIES TURBO TIMBALES (PATENTED)

The MEINL Turbo Timbales come with extra deep shells for super projection and great bass tones. Black

powder coating on the outside produces a dry, crisp and warm response.

SIZES 14" & 15"

10" deep

MATERIAL Black powder coated steel

FEATURES Three worked-in flanges
Heavy Duty style brackets
Logo applied from underneath the head (CN, US patent)

INCLUDES Adjustable cowbell holder
Height adjustable tilting double braced tripod stand
Accessory pouch
L-shaped tuning key
Tune Up oil

COLOUR **BK:** Black

ARTIST & PROFESSIONAL SERIES TIMBALES

1



LUIS CONTE, USA

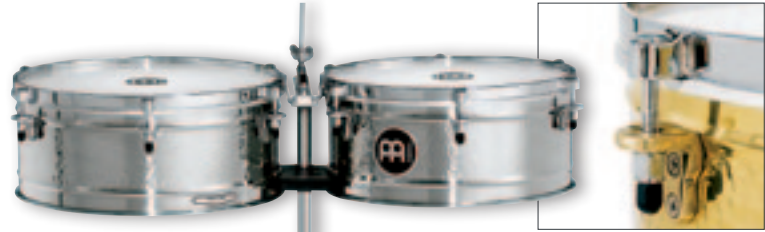

Stainless steel, 14" & 15"
LC1STS



Solid brass, 14" & 15"
LC1BRASS

COUNTER SUNK BOLT HEAD AND BRACKET
CAST FROM SPECIAL ALLOY

Luis Conte



TIMBALES

2



Roland Stein

THOUGHTFULLY ARRANGED LUGS ENABLE
AN EASY WAY TO PLAY THE CASCARA



German B8 cymbal bronze, 14" & 15"
BT1415

1 ARTIST SERIES TIMBALES (LUIS CONTE) (PATENTED)

It is with the greatest appreciation and the deepest respect that we honour our friend Luis and his life's work with his MEINL Artist Series Luis Conte Signature Timbales. Perfection in even the smallest details has been achieved in this outstanding instrument. All of the specifications Luis required for his instrument have been consequently realized.

SIZES 14" & 15"

MATERIALS **LC1BRASS:** Solid brass

LC1STS: Stainless steel

FEATURES Extensively hammered shells
Two worked in flanges
Cuban style flared out bottom edge

INCLUDES Adjustable cowbell holder
Height adjustable tilting double braced tripod stand
Accessory pouch
L-shaped tuning key
Tune Up Oil

2 PROFESSIONAL SERIES TIMBALES (PATENTED)

The Roland Meinl Professional Series Timbales are made from finest German B8 cymbal bronze. They produce a fantastic warm sound with cutting rim shots and enhanced Cascara playing.

SIZES 14" & 15"
MATERIAL German B8 cymbal bronze
FEATURES Two worked in flanges
Cuban style flared out bottom edge
Brackets cast from special brass alloy
Logo applied from underneath the head (CN, US patent)
INCLUDES Adjustable cowbell holder
Height adjustable tilting double braced tripod stand
Accessory pouch
L-shaped tuning key
Tune Up Oil



DIRK VERBEUREN, BELGIUM



BENNY GREB, GERMANY



BRAM HAKKENS, NETHERLANDS



TOMMY CLUFETOS, USA

ADD PERC TO YOUR KIT

Tommy Clufetos (Ozzy Osbourne) uses MEINL Professional Congas and Attack Timbales in his setup.



JULIO FIGUEROA, USA



JOHNNY RABB, USA



GREG BISHOP, UK





DRUMMER TIMBALES & HAND-BALE

1



Black, 10"
MDST10BK



Black, 8"
MDST8BK



2

SNARE WIRES ARE ABSOLUTELY QUIET AND CHATTER-FREE IN THE "OFF" POSITION



Chrome, 8" & 10"
MIT810CH



Chrome, 13"
MDT13CH



CHAD WACKERMAN, USA

1 DRUMMER SNARE TIMBALES (PATENTED)

The Drummer Snare Timbales feature a crisp snare effect. The super-positive snare throw-off is fast and simple. We designed a special bracket to hold the snare wires absolutely quiet and chatter-free in the "off" position.

SIZES 8", 10"

MATERIAL Steel

FEATURES Strong mounting clamp
Quick snare on/off system
Chatter-free "off" position
Logo applied from underneath the head (CN, US patent)

COLOUR **BK:** Black

2 DRUMMER TIMBALE MINI TIMBALES (PATENTED)

The MEINL Drummer and Mini Timbales provide the characteristic timbale sounds and projection that cuts through any band setting. It is a perfect addition to any percussion or drum set configuration.

SIZES **MDT13CH:** 13" drummer timbale

MIT810CH: 8" & 10" mini timbale

MATERIAL Steel

FEATURES Strong mounting clamp
Logo applied from underneath the head (CN, US patent)

INCLUDES L-shaped tuning key

Tune Up Oil

FINISH Chrome



TAKU HIRANO, USA

3



SPECIAL DESIGNED RIM

Black, 13"
MHT13BK



4



STRONG MOUNTING CLAMPS



DAVE MACKINTOSH, UK

Black nickel, 8"x9", 8"x11"
MDT88BN

3 ARTIST SERIES HAND-BALE (TAKU HIRANO) (PATENTED)

No sticks? No problem!
The retaining rim of the Hand-Bale is uniquely made with one half traditionally shaped, while the other half of the rim is recessed below the shell.

- SIZE 13"
- MATERIAL Steel
- FEATURES Special designed rim
Strong mounting clamp
Logo applied from underneath the head (CN, US patent)
- INCLUDES L-shaped tuning key
Tune Up Oil
- COLOUR **BK**: Black, high gloss

4 ARTIST SERIES ATTACK TIMBALES (DAVE MACKINTOSH) (PATENTED)

We made a pair of 8" diameter timbale shells with a depth of 9" and 11" respectively. This creates a distinctive and tightly matched interval "dialogue". The Dave Mackintosh's Signature Attack Timbales are easily mounted on a rack, drum set, or any standard L-rod.

- SIZES 8" x 9", 8" x 11"
- MATERIAL Steel
- FEATURES Strong mounting clamps
Logo applied from underneath the head (CN, US patent)
- INCLUDES L-shaped tuning key
Tune Up Oil
- COLOUR **BN**: Black Nickel

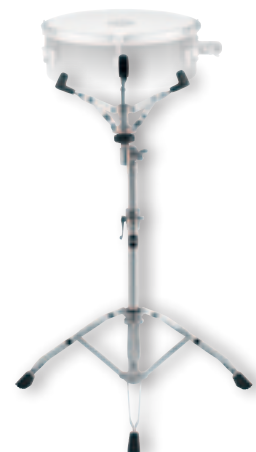

TMTS

HAND-BALE STAND (SEE PAGE 169)



HOW WE MAKE IT

SAMBA

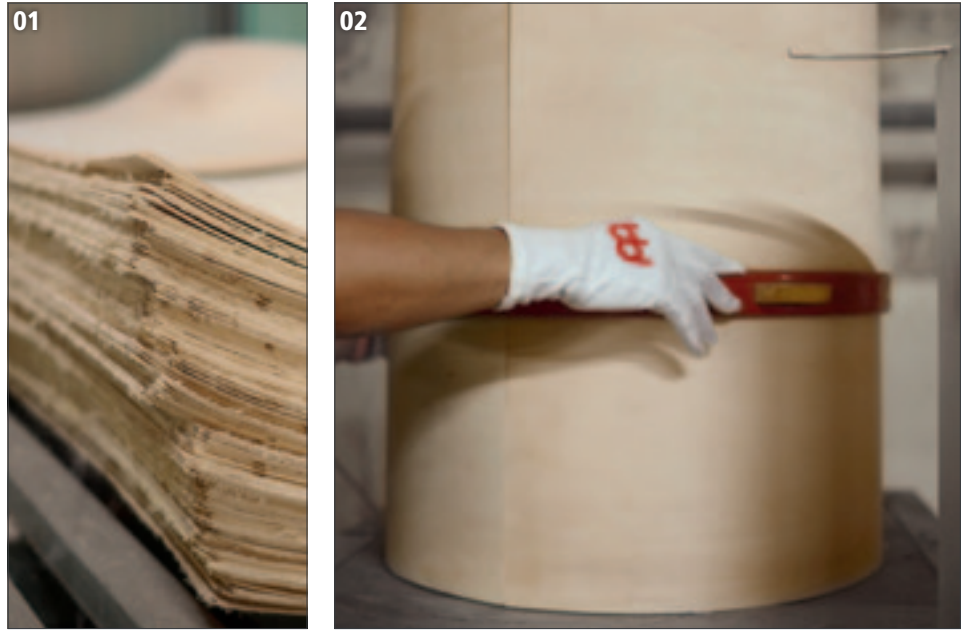

01 Sheets of Poplar Wood for our timbas.

02 A wooden surdo in formation.

03 Initial forming of a surdo body.

04 Surdo body heli-arc welded.

05 The surdos legs have to be parallel.

06 Setting up the surdo with its tuning rods.

07 Tamborim head in the press.

08 The head is fitted to the tamborim.

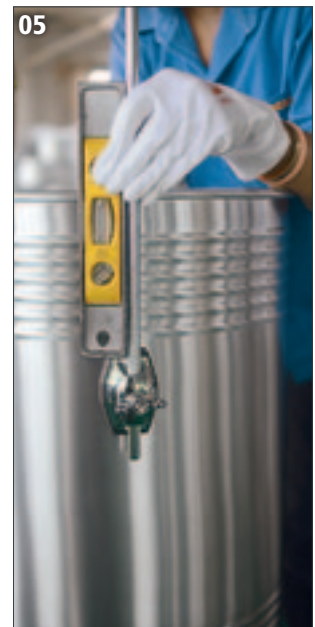

06



07

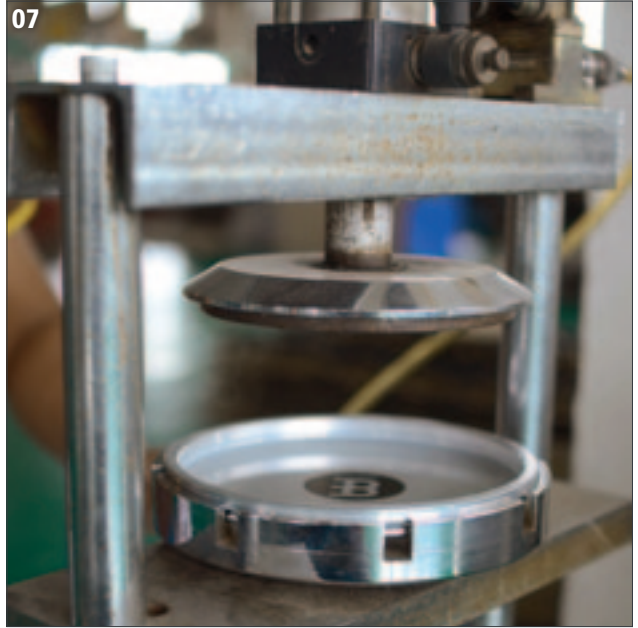

08



**PUTTING THE
LOGO ON A REBOLO.**



THE ORIGINAL DANCE MUSIC



WOUTER DE GOOYERT,
NETHERLANDS



CHARLY BÖCK, GERMANY



MARCO CATINACCIO, ITALY

TOMBACK, ECUADOR

1



LIGHT WEIGHT ALUMINIUM

22"
SU22

20"
SU20

18"
SU18

16"
SU16

2



ALL MEINL SURDOS COME WITH NAPA HEAD
ON TOP FOR ANOTHER HEAD OPTION

22"
SU22AB-M

20"
SU20AB-M

18"
SU18AB-M

16"
SU16AB-M

1 TRADITIONAL ALUMINIUM SURDOS (PATENTED)

The deep sound of the Surdo is the heartbeat of Samba music. MEINL offers several sizes made from premium aluminum.

SIZES 16" x 20", 18" x 22", 20" x 24", 22" x 24"

MATERIAL Aluminum

FEATURES Countersunk bolt heads
Chrome plated hardware
Two head options
8 tuning lugs (16" & 18" models)
10 tuning lugs (20" & 22" models)
Logo applied from underneath the head (CN, US patent)

INCLUDES Tuning key

2 TRADITIONAL WOOD SURDOS (PATENTED)

The MEINL Wood Surdos have all the great features of our Aluminium Surdos, but with wooden shells for a warmer sound. They deliver the full bass notes that are the heartbeat of Samba music.

SIZES 16" x 20", 18" x 22", 20" x 24", 22" x 24"

MATERIAL Six-ply hardwood shells

FEATURES Countersunk bolt heads
Chrome plated hardware
Two head options
8 tuning lugs (16" & 18" models)
10 tuning lugs (20" & 22" models)
Logo applied from underneath the head (CN, US patent)

INCLUDES Tuning key
COLOUR AB: African Brown
FINISH Matte



JOSÉ J. CORTIJO, GERMANY

STAND ALONE SURDOS

SAMBA

1



22"
SU22-L

20"
SU20-L

18"
SU18-L

16"
SU16-L

2



22"
SU22-L-AB-M

20"
SU20-L-AB-M

18"
SU18-L-AB-M

16"
SU16-L-AB-M

SIX-PLY HARDWOOD SHELLS FOR A FULL AND WARM SOUND

1 TRADITIONAL STAND ALONE ALUMINUM SURDOS (PATENTED)

MEINL percussion offers stand alone Surdos made out of aluminum that are equipped with sturdy, height adjustable legs placed on the floor while playing.

SIZES 16" x 20", 18" x 22", 20" x 24", 22" x 24"

MATERIAL Aluminum

FEATURES Height adjustable legs
Countersunk bolt heads
Chrome plated hardware
Two head options
8 tuning lugs (16" & 18" models)
10 tuning lugs (20" & 22" models)
Logo applied from underneath the head (CN, US patent)

INCLUDES Tuning key

2 TRADITIONAL STAND ALONE WOOD SURDOS (PATENTED)

The MEINL Stand Alone Wood Surdos have all the great features of our aluminum surdos, but with wooden shells for a warmer sound. They deliver the full bass notes that are the heartbeat of Samba music. These surdos are perfect for stationary playing, on stage, or in a drum circle!

SIZES 16" x 20", 18" x 22", 20" x 24", 22" x 24"

MATERIAL Six-ply hardwood shells

FEATURES Height adjustable legs
Countersunk bolt heads
Chrome plated hardware
Two head options
8 tuning lugs (16" & 18" models)
10 tuning lugs (20" & 22" models)
Logo applied from underneath the head (CN, US patent)

INCLUDES Tuning key
COLOUR **AB:** African Brown
FINISH Matte

1



22"
SUB22

20"
SUB20

18"
SUB18

SHORTER SHELLS
ENABLE TO WEAR IN MUCH LOWER POSITION

3



22"
HEAD-69



20"
HEAD-68



18"
HEAD-67



16"
HEAD-66

2



22"
SUB22AB-M

20"
SUB20AB-M

18"
SUB18AB-M

1 BAHIA ALUMINUM SURDOS (PATENTED)

Bahia Surdos are made to celebrate Samba-Reggae. Each surdo is cut shorter than its Rio counterpart and typically worn much lower, on a belt. Our three sizes offer two great sounding fundos and a higher pitched third surdo. Each surdo is cut shorter than its Rio counterpart, and typically worn much lower, on a belt.

SIZES 18" x 16", 20" x 16", 22" x 18"

MATERIAL Aluminum

FEATURES Countersunk bolt heads
Chrome plated hardware
Two head options
8 tuning lugs (18" model)
10 tuning lugs (20" & 22" models)
Logo applied from underneath the head (CN, US patent)

INCLUDES Tuning key

2 BAHIA WOOD SURDOS (PATENTED)

Our wooden Bahia Surdos celebrate Samba-Reggae music with warm-sounding shells. The three sizes offer the classic high-low fundos and a higher pitched third surdo. Each surdo is cut shorter than its Rio counterpart, and typically worn much lower, on a belt.

SIZES 18" x 16", 20" x 16", 22" x 18"

MATERIAL Six-ply hardwood shells

FEATURES Countersunk bolt heads
Chrome plated hardware
Two head options
8 tuning lugs (18" model)
10 tuning lugs (20" & 22" models)
Logo applied from underneath the head (CN, US patent)

INCLUDES Tuning key

COLOUR **AB:** African Brown

FINISH Matte

3 NAPA HEADS

The MEINL Napa Heads feature a two-layer construction with a strong, thin Mylar (plastic) under layer, and a soft Napa surface, securely bound together in a metal hoop.

SIZES 16", 18", 20", 22"

MATERIALS Nylon and leather cloth

FEATURE Bonded in a hoop

COLOUR Black

CAIXAS & REPINIQUES

1



14" x 4"
CA14



12" x 4 1/2"
CA12

PROFESSIONAL SNARE
THROW-OFF MECHANISM



GILSON SILVEIRA, ITALY

2



12" x 6"
CA12T

TRADITIONAL STYLE WITH
GUITAR STRINGS

3



12" x 12"
RE12

10" x 10"
RE10



COUNTERSUNK BOLT HEAD

4



12" x 12"
RE12AB-M



CAIXAS 1 2

With shells made from premium aluminum, these caixas produce the classic bright and cutting sound with penetrating rim shots that these instruments are supposed to deliver.

MATERIAL Aluminum

INCLUDES Tuning key

1 ALUMINUM CAIXAS (PATENTED)

SIZES 12" x 4 1/2"
14" x 4"

FEATURES Replaceable synthetic heads
Countersunk bolt heads
Steel snare wires
Logo applied from underneath the head (CN, US patent)
Professional snare throw-off mechanism

2 TRADITIONAL ALUMINUM CAIXA (PATENTED)

SIZE 12" x 6"

FEATURES Traditional style snares made from guitar strings
Extra deep body
Countersunk bolt heads
Logo applied from underneath the head (CN, US patent)
Replaceable synthetic heads

REPINIQUES 3 4

The Repinique is played with a stick while the other hand is used for open tones and slaps. MEINL offers aluminum and wooden versions.

FEATURES Countersunk bolt heads
Chrome plated hardware
Replaceable synthetic heads

6 tuning lugs (10" model)
8 tuning lugs (12" model)
Logo applied from underneath the head (CN, US patent)

INCLUDES Tuning key

3 ALUMINUM REPINIQUES (PATENTED)

SIZES 10" x 10"
12" x 12"

MATERIAL Aluminum

4 WOOD REPINIQUE (PATENTED)

SIZE 12" x 12"

MATERIAL Rubber Wood
(*Hevea brasiliensis* Muell.-Arg.)

COLOUR **AB:** African Brown

FINISH Matte



TIMBAS & TANTAM & REBOLO

1

NEW! NEW!



14" x 35"
TIM1435AB-M

14" x 28"
TIM1428AB-M

14" x 35"
TIM1435NT

14" x 28"
TIM1428NT

2



NAPA HEAD FOR REDUCED OVERTONES



12" x 18"
REB1218AB-M

3



STRONG HOOK TO CARRY IT ON A BELT



14" x 28"
TAN1428AB-M

4



SB-R



MARCIO PEETER, USA

1 TIMBAS (PATENTED)

The MEINL Timba has a light weight shell, a thin synthetic head, and mechanical lug tuning. The tones are sharp, clear, and bright.

SIZES 14" x 28", 14" x 35"

MATERIAL Poplar Wood (*Populus*)

FEATURES Light weight shell
Replaceable synthetic head
Chrome plated hardware
Comfortable rounded rim
Logo applied from underneath the head (CN, US patent)
Strong hook to carry it on a belt

INCLUDES Tuning key

COLOURS **AB:** African Brown, matte
NT: Natural, high gloss

2 REBOLO

The Rebolo is a Brazilian ensemble drum with warm, deep tones. It comes with a Napa head and is usually played in the seated position.

SIZE 12" x 18"

MATERIAL Poplar Wood (*Populus*)

FEATURES Lightweight shell
Replaceable synthetic Napa head
Chrome plated hardware
Mechanical lug tuning
Strong hooks to carry it on a belt

INCLUDES Tuning Key

COLOUR **AB:** African Brown
FINISH Matte

3 TANTAM

The Tantam is a drum with warm, deep tones, usually played in Pagode, a specific genre of samba.

SIZE 14" x 28"

MATERIAL Poplar Wood (*Populus*)

FEATURES Lightweight shell
Replaceable synthetic Napa head
Chrome plated hardware
Strong hooks to carry it on a belt

INCLUDES Tuning key

COLOUR **AB:** African Brown

FINISH Matte

4 SAMBA BELT

MEINL offers a high quality belt to ensure a safe and comfortable playing of several samba instruments.

MATERIAL Cotton

FEATURES Length adjustable
Adjustable shoulder padding
Strong attachment hooks

COLOUR **R:** Red

CUICAS & WHISTLE & ROCARS & TRIANGLE



10"
QW10

6"
QW6



8"
QW7R

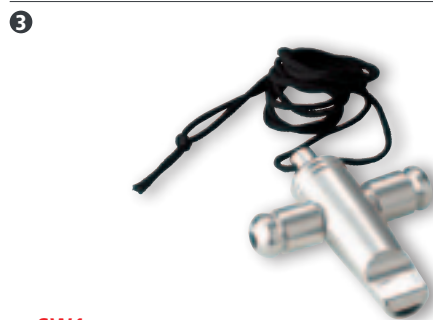

SW1

THREE TONES

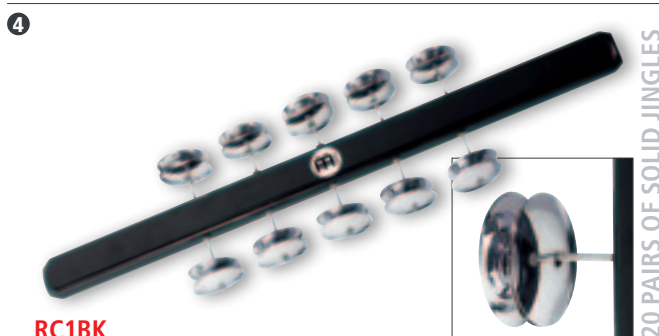

RC1BK

20 PAIRS OF SOLID JINGLES



RC2-L



15 3/4"
STRI40

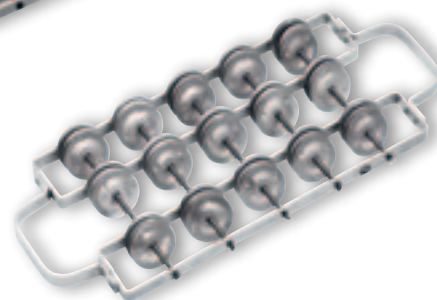

RC2-M

1 ALUMINUM CUICAS

MEINL offers two cuicas made from lightweight aluminum. Their light weight and solid construction makes them perfect for street Samba.

SIZES 6", 10"

MATERIAL Aluminum

FEATURES Countersunk bolt heads (QW10)
Hand selected goat heads

INCLUDES Tuning key

FEATURES Floatune Tuning System
Hand selected goat head

INCLUDES Tuning key

3 SAMBA WHISTLE

This samba whistle has three tones in a super-bright timbre.

MATERIAL Aluminum

INCLUDES Neck lanyard

2 FIBERGLASS CUICA

While one hand rubs the internal bamboo shaft with a moist cloth, the other hand controls the pressure of the head, thereby changing the pitch.

SIZE 8"

MATERIAL Premium fiberglass

COLOUR R: Red

4 MODERN STYLE ROCAR

The MEINL Rocar is equipped with 20 pairs of solid jingles mounted onto a wooden bar.

MATERIAL Rubber Wood
(*Hevea brasiliensis* Muell.-Arg.)

FEATURE 20 pairs of solid jingles

COLOUR BK: Black

5 SAMBA TRIANGLE

The Samba Triangle is made extra large for a bold sound that can be heard over a Samba ensemble.

SIZE 15 3/4"

MATERIAL Steel

FEATURE Thick steel for extra volume

INCLUDES Extra large Triangle Beater

6 ALUMINUM ROCARS

The MEINL Aluminum Rocars come in lightweight frames that hold an array of cupped aluminum jingles.

SIZES Medium

Large

MATERIAL Aluminum frame and jingles

FEATURES Light weight frame

Loud projection



A-GO-GOS & SHAKERS



Small
STBAG1

Large
STBAG2

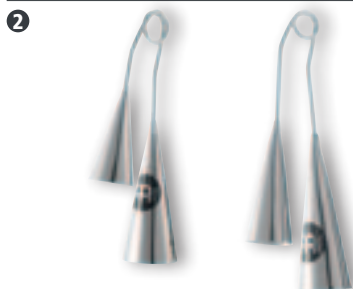

Small
STBAG4-CH

Large
STBAG2-CH

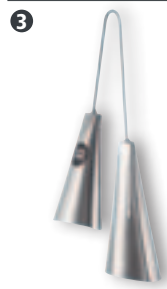

Medium
STBAG3-CH

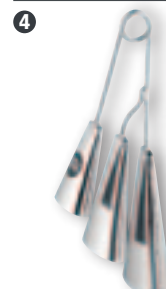

Medium
STBAGTRI-CH

TONALLY MATCHED



Small Single
SSH1-S

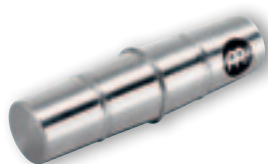

Medium Single
SSH1-M

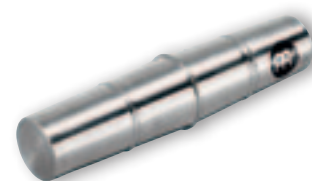

Large Single
SSH1-L

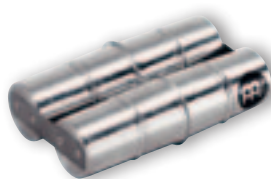

Small Double
SSH2-S



Medium Double
SSH2-M

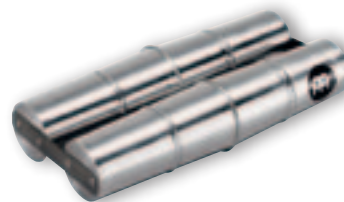

Large Double
SSH2-L

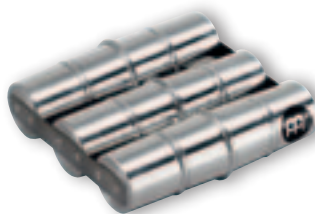

Small Triple
SSH3-S

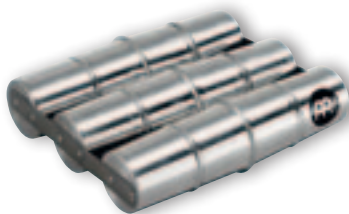

Medium Triple
SSH3-M



Large Triple
SSH3-L

LIGHT WEIGHT ALUMINIUM

1 MODERN STYLE A-GO-GO STEEL FINISH MODELS

The MEINL A-Go-Go Bells are tonally matched especially for the requirements of South American rhythms.

SIZES Small, Large

MATERIAL Special steel alloy

INCLUDES Mounting clamp for small model

FINISH Hand brushed steel

2 MODERN STYLE A-GO-GO CHROME FINISH MODELS

These highly polished A-Go-Go Bells offer a bright sound and are equipped with a flexible connection. Ideal for Samba style music.

SIZES Small, Large

MATERIAL Special steel alloy

FEATURE Flexible connection

FINISH High polished chrome

3 TRADITIONAL STYLE A-GO-GO BELL

The MEINL traditional style A-Go-Go Bell in our medium size is the perfect A-Go-Go Bell when the large is too much and the small one isn't enough.

SIZE Medium

MATERIAL Special steel alloy

FEATURES Traditional shape

Flexible connection

FINISH High polished chrome

4 TRIPLE A GO-GO BELL

The Triple A Go-Go Bell has three tonally matched bells for a sweet sound fitting any musical style. The high bell may be played in counterpoint off the middle bell by compressing the spring handle. Bright chrome finish will hold up under intense play.

SIZE Medium

MATERIAL Chrome plated steel

FEATURES Traditional Shape

Tonally matched bells in equal intervals

Spring handle enables counterpoint

rhythms

FINISH Chrome

5 ALUMINUM SAMBA SHAKERS

This are the ideal instruments for street Samba. Their shells are made from thin aluminum, which, when combined with solid steel shot, produce a warm, penetrating, and cutting shaker sound.

SIZES Small, Medium, Large

MATERIAL Aluminum

TAMPEIRO & TAMBORIMS

1

INVENTOR:
JOSÉ J. CORTIJO



THREE PAIRS OF
STEEL JINGLES

Rubber Wood, African Brown
TP06AB-M

2



MESH HEAD FOR SUPER
LOW VOLUME PRACTICE

STBR06ABS-BK

3



ABS, Black
TBR06ABS-BK



ABS, Red
TBR06ABS-R



ABS, Green
TBR06ABS-GR



Chrome
TBR06CH



Brass
TBR06B



ABS, Yellow
TBR06ABS-Y

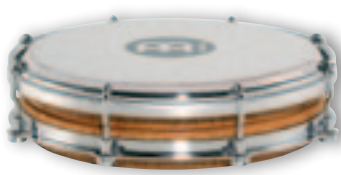

Rubber Wood, Super Natural
TBR06SNT-M



Aluminum
TBR06ALU

4



HEAD-79

WE OFFER A VARIETY OF TAMBORIMS FROM SEVERAL
MATERIALS FOR DIFFERENT SOUND OPTIONS

1 TAMPEIRO (PATENTED)

Three pairs of steel jingles on a wooden tamborim frame create an exciting new sound. A traditional sharp cutting tamborim with a bright metallic accent! It may also be played with pandeiro techniques, for lighter accompaniment.

SIZE 6"

MATERIAL Rubber Wood
(*Hevea brasiliensis* Muell.-Arg.)

FEATURES Floatune Tuning System
Logo applied from underneath the head
(CN, US patent)
Countersunk bolt lugs
Replaceable synthetic head
Three pairs of steel jingles

INCLUDES Thai coin as tuning key

COLOUR **AB:** African Brown

2 SILENT TAMBORIM

The MEINL Silent Tamborim is meant for the serious player who wants to perfect their tamborim technique.

SIZE 6"

MATERIALS ABS plastic
Mesh head

FEATURE Mesh head for super low volume practice

COLOUR **BK:** Black

3 FLOATUNE TAMBORIMS (PATENTED)

Tamborims are played with a plastic stick while one hand changes the pitch of the drum. It has a bright, loud, and cutting sound.

SIZE 6"

MATERIALS **ABS:** ABS
ALU: Aluminum

B: Brass plated steel

CH: Chrome plated steel

SNT: Rubber Wood
(*Hevea brasiliensis* Muell.-Arg.)

FEATURES Floatune Tuning System
Logo applied from underneath the head
(CN, US patent)
Countersunk bolt lugs
Replaceable synthetic heads

INCLUDES Thai coin as tuning key

4 MESH HEAD FOR TAMBORIMS

The Mesh Head meant for the serious player who wants to perfect their Tamborim technique. Hours of quiet play are possible without sonic overload.

SIZE 6"

MATERIAL Mesh head



HOW WE MAKE IT

FRAME DRUMS

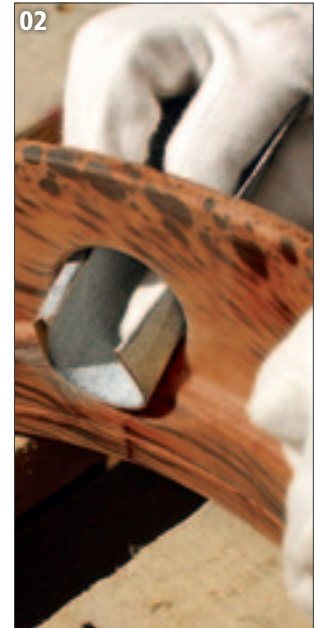

01 After bending the frame, it gets glued and cut into the proper shell depth.

02 The thumb hole of our deep shell frame drums has to be comfortable. Even after the finish is dry we check again.

03 All skins are carefully inspected for faultless quality.

04 A frame is being set with glue, just before the skin goes on.

05 The head is secured to the frame with glue and a band.

06 The extra skin is being removed. The frame drum is sitting inside a cutting guide jig ensuring a perfect cut.

07 The head is tacked securely to the frame.

08 Mounting a True Feel head on a deep shell frame drum.

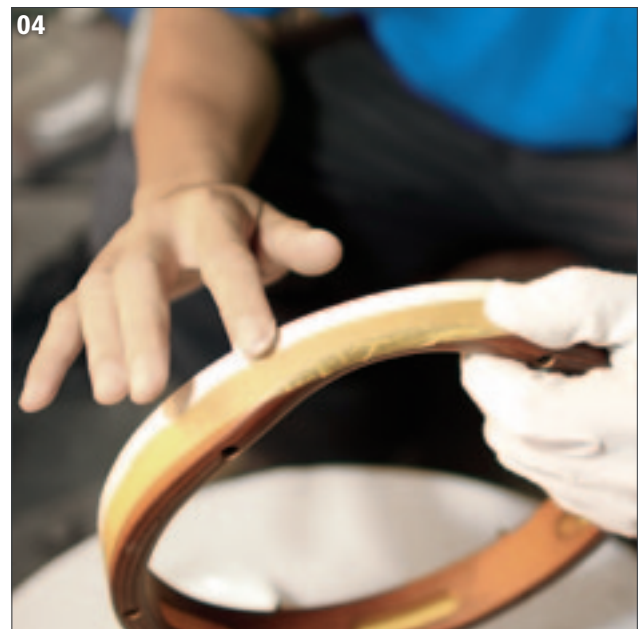

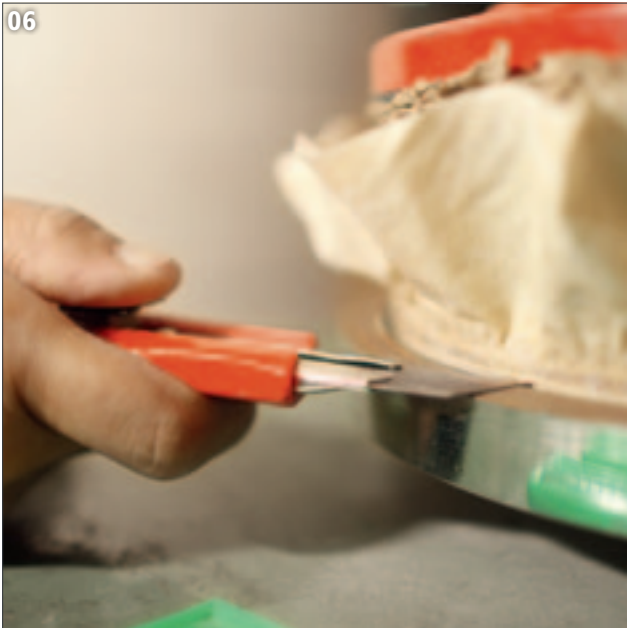

1



22" x 2 1/2"
FD22T



20" x 2 1/2"
FD20T



18" x 2 1/2"
FD18T



16" x 2 1/2"
FD16T



INTERNAL LUG TUNING SYSTEM

2



22" x 2 1/2"
FD22T-TF

TRUE FEEL SYNTHETIC HEADS PREVENT THE DRUM'S PITCH FROM BEING AFFECTED BY HUMIDITY IN OUTDOOR VENUES



20" x 2 1/2"
FD20T-TF



18" x 2 1/2"
FD18T-TF



16" x 2 1/2"
FD16T-TF



TARS 1 2

MEINL Tars are tunable frame drums, available with hand selected goatskin or True Feel synthetic heads. The tuning lugs are fully recessed within the frame for minimal interference. A scalloped thumb notch and light weight ensure comfortable playing.

SIZES 16", 18", 20", 22"
2 1/2" deep

FEATURE Internal lug tuning system

INCLUDES Allen wrench

COLOUR African Brown

FINISH Matte

1 GOAT SKIN TARS

MATERIALS Rubber Wood
(*Hevea brasiliensis* Muell.-Arg.)
Hand selected goat head

2 SYNTHETIC HEAD TARS

MATERIALS Rubber Wood
(*Hevea brasiliensis* Muell.-Arg.)
True Feel synthetic head



TAKU HIRANO, USA

MIZHARS

1



18" x 4"
FD18T-D

DEEP SHELL CONSTRUCTION
FOR FULL SOUND DEVELOPMENT



14" x 4"
FD14T-D



12" x 4"
FD12T-D

FRAME DRUMS

2



18" x 4"
FD18T-D-TF



14" x 4"
FD14T-D-TF



12" x 4"
FD12T-D-TF

MIZHARS 1 2

Mizhars have an internal tuning system, and a traditional thumb hole grip for comfortable playing in the traditional style. The deep shell offers excellent sound development and comes in a stunning burl finish. Those drums are available with a hand selected goat head or with a True Feel synthetic head.

SIZES 12", 14", 18"
4" deep

FEATURES Thumb hole grip
Deep shell construction for full sound development
Internal tuning system
Stunning burl finish

INCLUDES Allen wrench

COLOUR Brown Burl

FINISH Matte

1 GOAT SKIN MIZHARS

MATERIALS Rubber Wood
(*Hevea brasiliensis* Muell.-Arg.)
Hand selected goat head

2 SYNTHETIC HEAD MIZHARS

MATERIALS Rubber Wood
(*Hevea brasiliensis* Muell.-Arg.)
True Feel synthetic head

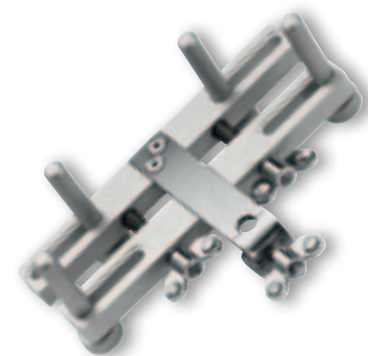

MC-FDH

FRAME DRUM HOLDER (SEE PAGE 172)



BENDIRS 1 2

Bendirs feature four thin strings stretched across the inside of the head, which create the classic Bendir "buzzing" sound. Those drums are fully tunable and light in weight for long and comfortable playing. MEINL offers goatskin as well as synthetic True Feel head versions. This fine frame drums are fully tunable, with rich bass tones and crisp taks. The frame is made for comfort and extended play.

SIZES 12" x 4"
14" x 4"
16" x 2 1/2"

FEATURES Internal tuning system
Buzzing effect
Thumb hole for a good balance and comfortable playing (only for 4" deep frames)

INCLUDES Allen wrench
COLOUR African Brown
FINISH Matte

1 GOAT SKIN BENDIRS

MATERIALS Rubber Wood
(*Hevea brasiliensis* Muell.-Arg.)
Hand selected goat head

2 SYNTHETIC HEAD BENDIRS

MATERIALS Rubber Wood
(*Hevea brasiliensis* Muell.-Arg.)
True Feel synthetic head

BODHRANS 3 4

Bodhrans are known for their earthy and warm tones. MEINL offers two different versions, a Celtic model featuring a cross bar and an Irish model that comes with an extra deep frame and a dampening layer on the head.

3 CELTIC BODHRAN

SIZE 18" x 4"
MATERIALS Rubber Wood
(*Hevea brasiliensis* Muell.-Arg.)
Hand selected goat head

FEATURES Cross bar
Internal tuning system

INCLUDES Allen wrench
COLOUR African Brown
FINISH Matte

BODHRANS & DAFS & KANJIRA

3



18" x 4"
FD18BO



CROSS BAR

4



14" x 6"
FD14IBO

DAMPENING LAYER FOR LESS OVERTONES

5



20" x 2 1/2"
FD20D-TF

20" x 2 1/2"
FD20D-WH

METAL RINGS FOR SPECIAL EFFECTS

6



7 1/2" x 2 1/4"
FD7KA



RAMESH SHOTHAM,
GERMANY

4 IRISH BODHRAN

The Irish Bodhran features an extra-deep shell for a rich, full sound, and an extra dampening layer on the rim to reduce overtones. The traditional cross brace has been removed to enable direct hand pressure on the head for contemporary pitch-bending techniques.

SIZE 14" x 6"

MATERIALS Rubber Wood
(*Hevea brasiliensis* Muell.-Arg.)
Hand selected goat head

FEATURES Extra deep shell for full sound development
Dampening layer around rim for reduced overtones

INCLUDES Allen wrench

COLOUR Brown Burl

FINISH Matte

5 DAFS

The Daf is a classical Persian frame drum with a rich tradition. It has ring snares nearly all the way around the inside of the shell, and is played with a lot of movement. The MEINL Daf comes either with the a True Feel synthetic head or with a woven texture synthetic head.

SIZE 20" x 2 1/2"

MATERIALS Rubber Wood
(*Hevea brasiliensis* Muell.-Arg.)

FD20D-TF: True Feel synthetic head

FD20D-WH: Woven synthetic head

FEATURES Metal rings for special effects
Pre-tuned construction for extra light weight

COLOUR African Brown

FINISH Matte

6 KANJIRA

The Kanjira is a traditional frame drum from southern India that is played with bending-pitch and split hand techniques. Amazing sounds and complex rhythms are possible from this rich little drum.

SIZE 7 1/2" x 2 1/4"

MATERIALS Rubber Wood
(*Hevea brasiliensis* Muell.-Arg.)
Hand selected goat head

FEATURES Many sound options
Set of 3 jingles

INCLUDES Allen wrench

COLOUR African Brown

FINISH Matte



HOW WE MAKE IT

ARTISAN EDITION TARS & MIZHARS

MEINL is proud to announce that well known frame drum maker Norbert Eckermann will be working with MEINL Percussion to further develop our frame drum line.

NORBERT ECKERMANN



The new Artisan Edition Frame Drums are the result of this promising collaboration. The combined effort between Eckermann and MEINL will produce the most outstanding frame drums available today.



01 Milling a special bearing edge into the frame.

02 Cutting frame into two halves for Tars.

03 Hot branding the logo into the frame.

04 Only highest grade hides are used for our Artisan Edition Frame Drums!



ARTISAN EDITION TARS & MIZHARS

1



22" x 2 1/2"
AE-FD22T

18" x 2 1/2"
AE-FD18T

14" x 2 1/2"
AE-FD14T

2



22" x 4"
AE-FD22T-D

18" x 4"
AE-FD18T-D

14" x 4"
AE-FD14T-D

1 ARTISAN EDITION TARS (PATENT PENDING)

The MEINL Artisan Edition Tar, is an instrument like no other and a must have for serious players. The heads are made using the highest grade hides available – selected for uniform thickness to give consistent warm tone and response. This drums feature a special bearing edge exclusively designed for our Artisan Edition Tars by Norbert Eckermann.

SIZES 14", 18", 22"; 2 1/2" deep

MATERIALS Rubber Wood
(*Hevea brasiliensis* Muell.-Arg.)
Hand selected goat head

FEATURES Special designed bearing edge (patent pending)
Using highest grade hides available
Internal lug tuning system
Scalloped thumb notch
Hot-branded logo inside of the shell

INCLUDES Allen wrench
COLOUR Walnut Brown
FINISH Matte

2 ARTISAN EDITION MIZHARS (PATENT PENDING)

Originally from Syria, this ancient instrument provides harmonic and rhythmic foundation to the ensemble. In the new MEINL Artisan Edition Mizhars we have used the highest grade hides available – selected for uniform thickness to give consistent warm tone and response. A special designed bearing edge invented by Norbert Eckermann ensures deep dums and crisp taks (teks).

SIZES 14", 18", 22"; 4" deep

MATERIALS Rubber Wood
(*Hevea brasiliensis* Muell.-Arg.)
Hand selected goat head

FEATURES Special designed bearing edge (patent pending)
Using highest grade hides available
Internal tuning system
Thumb hole grip
Hot-branded logo inside of the shell

INCLUDES Allen wrench
COLOUR Walnut Brown
FINISH Matte



HOT-BRANDED LOGO
INSIDE OF THE SHELL

MEINL SEA DRUMS & HAND DRUMS & PLENERA SET

1



SEALABLE FILLING PORT ALLOWS YOU TO CONTROL THE AMOUNT OF STEEL BALLS INSIDE

20" x 2 3/4"
FD20SD

18" x 2 3/4"
FD18SD-TF

16" x 2 3/4"
FD16SD

2



8", 10", 12"
PL-SET

3



15"
HOD15

12 1/2"
HOD125

NEW!

4



16"
HD16AB

14"
HD14AB

12"
HD12AB

10"
HD10AB



22"
HD22AB-TF

20"
HD20AB-TF

18"
HD18AB-TF



16"
HD16AB-TF

14"
HD14AB-TF

12"
HD12AB-TF

10"
HD10AB-TF



1 SEA DRUMS

MEINL Sea Drums create the soothing sounds of the surf, with a great new feature: A sealable filling port allows you to control the amount of steel balls inside.

SIZES 16", 18", 20"
2 3/4" deep

MATERIALS Rubber Wood
(*Hevea brasiliensis* Muell.-Arg.)
Hand selected goat head and synthetic head
FD18SD-TF: True Feel synthetic head and transparent head

FEATURE Sealable filling port allows you to control the amount of steel balls inside

COLOUR African Brown
FINISH Matte

2 PLENERA SET

The Plenera is a traditional frame drum from Puerto Rico. The frames are made from rugged plastic and external mechanical lugs tune the hand selected goat-skin heads.

SIZES Quinto = 8"
Seguidor = 10"
Tumbador = 12"

MATERIALS ABS Plastic frames
Goatskin heads

FEATURE External mechanical lug tuning

INCLUDES Nylon Bag
Tuning Keys

3 NATIVE AMERICAN-STYLE HOOP DRUM

These frame drums have a hand selected buffalo head for an authentic sound that is both warm and powerful.

SIZES 12 1/2", 15"

MATERIALS Hand selected buffalo head
Nylon lacing and grip

FEATURES Warm and powerful sound
Adjustable hand grip

INCLUDES Leather padded wooden beater

4 HAND DRUMS

Hand Drums are equipped with either the finest hand selected goat heads or with our synthetic True Feel heads. The scalloped frame guarantees a comfortable grip.

SIZES **AB**: 10", 12", 14", 16"
AB-TF: 10", 12", 14", 16", 18", 20", 22"

MATERIALS Rubber Wood
(*Hevea brasiliensis* Muell.-Arg.)
Hand selected goat head

TF: True Feel synthetic head

COLOUR **AB**: African Brown

PANDEIROS

1



Napa head, 10"
PA10ABS-BK-NH

NAPA HEAD FOR
REDUCED OVERTONES



Clear Mylar head, 10"
PA10ABS-BK



2



Goat head, 12"
PA12CN-M



Goat head, 10"
PA10CN-M



SOLID JINGLES

3



Goat head, 12"
PA12AB-M



Goat head, 10"
PA10AB-M



HAND-HAMMERED
BRASS JINGLES

4



True Feel synthetic head, 12"
PAV12AB-M-TF



True Feel synthetic head, 10"
PAV10AB-M-TF



PERFORATED HAND-
HAMMERED BRASS JINGLES

PANDEIROS

The Pandeiro is played with one hand while the other alters the pitch of the drum. MEINL Pandeiros are available with different jingle and head variations.

1 TRADITIONAL ABS PANDEIROS

SIZE 10"

MATERIALS ABS plastic

PA10ABS-BK: Replaceable synthetic head
PA10ABS-BK-NH: Replaceable Napa head

FEATURES Countersunk bolt lugs
Chrome plated jingles and hardware

PA10ABS-BK: Logo applied from under-
neath the head (CN, US patent)
PA10ABS-BK-NH: Reduced overtones

INCLUDES Tuning key

COLOUR **BK**: Black

2 TRADITIONAL WOOD PANDEIROS

SIZES 10", 12"

MATERIALS Rubber Wood

(*Hevea brasiliensis* Muell.-Arg.)

REPLACEABLE HAND SELECTED GOAT HEADS

FEATURES Countersunk bolt lugs
Chrome plated jingles and hardware

INCLUDES Tuning key

COLOUR **CN-M**: Chest Nut, matte

3 SHELL-TUNED GOAT SKIN PANDEIROS

SIZES 10", 12"

MATERIALS Rubber Wood

(*Hevea brasiliensis* Muell.-Arg.)

HAND SELECTED GOAT HEAD

FEATURES Hand-hammered brass jingles

Internal lug tuning system

Light weight

INCLUDES Allen wrench

COLOUR **AB-M**: African Brown, matte

4 SHELL-TUNED SYNTHETIC HEAD PANDEIROS

SIZES 10", 12"

MATERIALS Rubber Wood

(*Hevea brasiliensis* Muell.-Arg.)

True Feel synthetic head

FEATURES Perforated hand-hammered brass jingles
for extra dry sound

Internal lug tuning system

Light weight

INCLUDES Allen wrench

COLOUR **AB-M**: African Brown, matte



HOW WE MAKE IT

TAMBOURINES



01

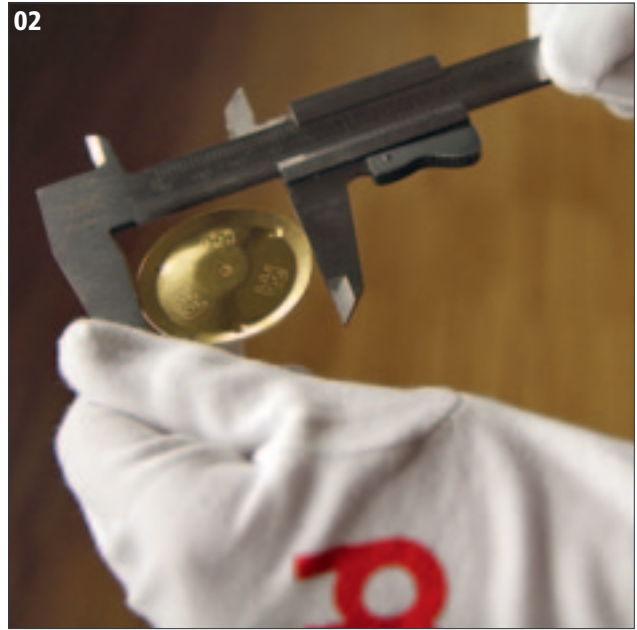

02

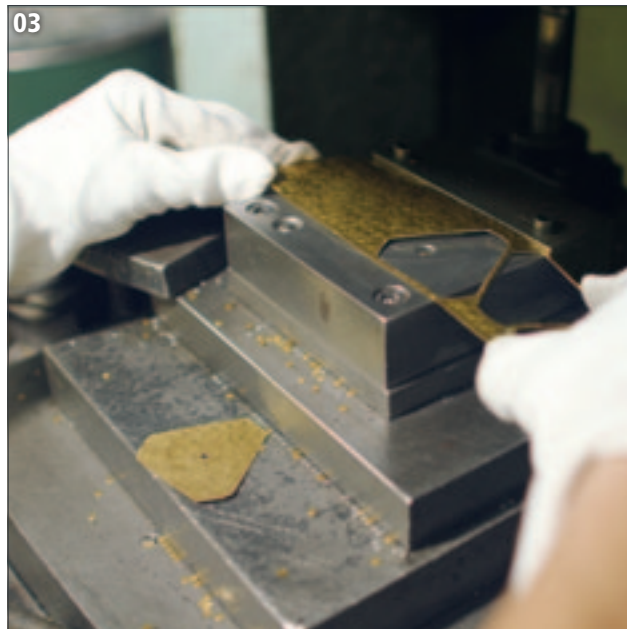

03

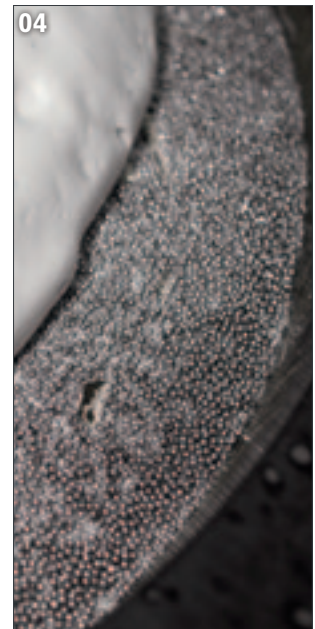

04

01 Forming the jingles.

02 Our jingles are precision made.

03 A brass super dry jingle is cut from the stock sheet.

04 The jingles are polished in a special bath with metal beads.

05 Every jingle has to be carefully checked before it can be mounted on a frame.

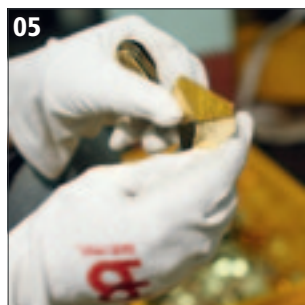

05

06 The jingle slots of this 2 row tambourine are being sanded. A person sands the slots of a tambourine frame.

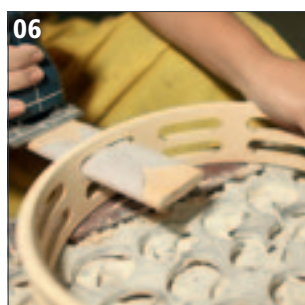

06

07 The tambourines are assembled by hand. A person assembles a tambourine frame.

08 The nails are also secured with glue. A person secures nails with glue.



07A

07B



08

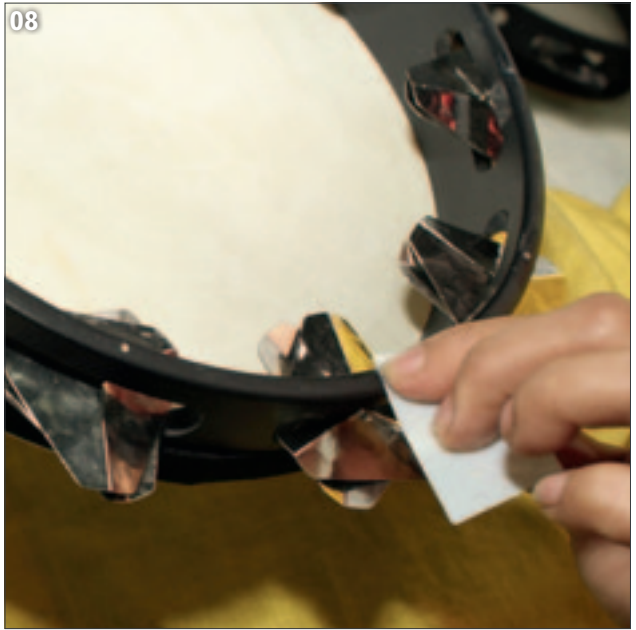

LOGO APPLIED WITH HOT
IRON BRAND ON OUR
ARTISAN EDITION
TAMBOURINES.



HEADED WOOD TAMBOURINES

1



1 row
TAH1AB



2 rows
TAH2AB

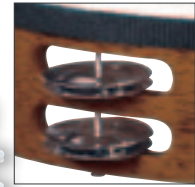

NICKELSILVER
PLATED STEEL

2



1 row
TAH1A-AB



2 rows
TAH2A-AB

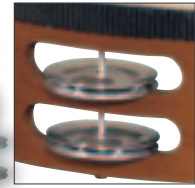

ALUMINUM

3



1 row
TAH1M-SNT



2 rows
TAH2M-SNT

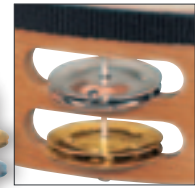

STEEL / SOLID BRASS

4

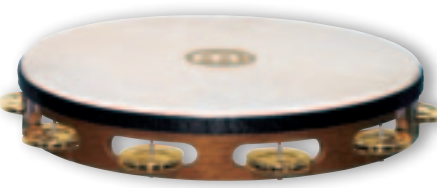

1 row
TAH1B-AB



2 rows
TAH2B-AB

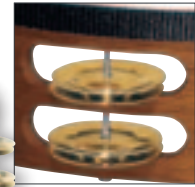

SOLID BRASS

HEADED WOOD TAMBOURINES

MEINL's Headed Wood Tambourines are made from a sturdy frame with jingles available in different materials, resulting in various sound possibilities. Each head is hand selected to provide best quality on these pre-tuned drums.

1 TRADITIONAL GOAT-SKIN WOOD TAMBOURINES, STEEL JINGLES

SIZE 10"

MATERIALS Nickelsilver plated steel
Hand selected goat heads
Wooden frame

FEATURE 1 row and 2 row version

COLOUR **AB**: African Brown

2 TRADITIONAL GOAT-SKIN WOOD TAMBOURINES, ALUMINUM JINGLES

SIZE 10"

MATERIALS Aluminum
Hand selected goat heads
Wooden frame

FEATURE 1 row and 2 row version

COLOUR **AB**: African Brown

3 RECORDING-COMBO GOAT-SKIN WOOD TAMBOURINES, DUAL-ALLOY JINGLES

SIZE 10"

MATERIALS Steel / Solid brass
Hand selected goat heads
Wooden frame

FEATURES Dual-alloy jingles

1 row and 2 row version

COLOUR **SNT**: Super Natural

4 TRADITIONAL GOAT-SKIN WOOD TAMBOURINES, BRASS JINGLES

SIZE 10"

MATERIALS Solid brass
Hand selected goat heads
Wooden frame

FEATURE 1 row and 2 row version

COLOUR **AB**: African Brown

5 NEW!

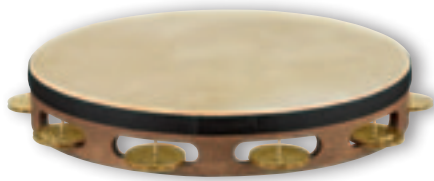

1 row
TAH1V-WB

NEW!



2 rows
TAH2V-WB



HAMMERED BRASS

6



1 row
TAH1BK-R-TF



2 rows
TAH2BK-R-TF

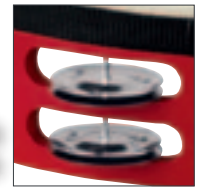

BLACK PLATED STEEL

7



1 row
STAH1S-BK



2 rows
STAH2S-BK



HAND-HAMMERED
STAINLESS STEEL

8



1 row
STAH1B-BK



2 rows
STAH2B-BK



HAND-HAMMERED
BRASS

5 VINTAGE GOAT SKIN WOOD TAMBOURINES
MEINL is bringing the old school tambourines back! The special designed jingles produce the legendary sound that was familiar a long time ago. These tambourines are equipped with the best quality goatskin head.

SIZE 10"

MATERIALS Hammered Brass
Hand selected goat heads
Wooden frame

FEATURES 1 Row and 2 row version
Legendary tambourine sound
Special profile jingles
Detailed with hot-branded logo

COLOUR **WB:** Walnut Brown

6 TOURING SYNTHETIC HEAD WOOD TAMBOURINES

SIZE 10"

MATERIALS Black plated steel
True Feel synthetic head
Wooden frame

FEATURES 1 Row and 2 row version
True Feel synthetic head

COLOUR **R:** Red

7 SUPER-DRY STUDIO GOAT SKIN WOOD TAMBOURINES, STAINLESS STEEL JINGLES

SIZE 10"

MATERIALS Hand-hammered stainless steel
Hand selected goat heads
Wooden Frame

FEATURES Hand-hammered triangular jingles for an extra sweet sound with short sustain
1 row and 2 row versions

COLOUR **BK:** Black

8 SUPER-DRY STUDIO GOAT SKIN WOOD TAMBOURINES, BRASS JINGLES

SIZE 10"

MATERIALS Hand-hammered brass
Hand selected goat heads
Wooden frame

FEATURES Hand-hammered triangular brass jingles for extra dry sound
1 row and 2 row version

COLOUR **BK:** Black

MEINL WOOD TAMBOURINES



1 row
TA1AB

2 rows
TA2AB



1 row
TA1A-AB

2 rows
TA2A-AB



1 row
TA1M-SNT

2 rows
TA2M-SNT



1 row
TA1B-AB

2 rows
TA2B-AB

WOOD TAMBOURINES

MEINL's Wood Tambourines are made from a sturdy frame with jingles available in different materials, resulting in various sound possibilities. Their ergonomically shaped handle and light weight enable energetic playing.

1 TRADITIONAL WOOD TAMBOURINES, STEEL JINGLES

SIZE 10"
MATERIALS Nickelsilver plated steel
Wooden frame
FEATURE 1 row and 2 row version
COLOUR **AB**: African Brown

2 TRADITIONAL WOOD TAMBOURINES, ALUMINUM JINGLES

SIZE 10"
MATERIALS Aluminum
Wooden frame
FEATURE 1 row and 2 row version
COLOUR **AB**: African Brown

3 RECORDING-COMBO WOOD TAMBOURINES, DUAL-ALLOY JINGLES

SIZE 10"
MATERIALS Steel / solid brass
Wooden frame
FEATURES Dual-alloy jingles
1 row and 2 row version
COLOUR **SNT**: Super Natural

4 TRADITIONAL WOOD TAMBOURINES, BRASS JINGLES

SIZE 10"
MATERIALS Solid brass
Wooden frame
FEATURE 1 row and 2 row version
COLOUR **AB**: African Brown

NEW!

5



1 row
TA1V-WB

2 rows
TA2V-WB



HAMMERED BRASS

6



1 row
STA1S-BK

2 rows
STA2S-BK



HAND-HAMMERED STAINLESS STEEL

7



1 row
STA1B-BK

2 rows
STA2B-BK

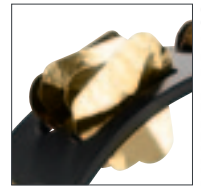

HAND-HAMMERED BRASS

5 VINTAGE WOOD TAMBOURINES

MEINL is bringing the old school tambourines back! The special designed jingles produce the legendary sound that was familiar a long time ago. Combined with a discreet and classy look these tambourines will make every percussionist proud.

SIZE 10"

MATERIALS Hammered brass
Wooden frame

FEATURES Legendary tambourine sound
Special profile jingles
Detailed with hot-branded logo

COLOUR **WB:** Walnut Brown

6 SUPER-DRY STUDIO WOOD TAMBOURINES, STAINLESS STEEL JINGLES

SIZE 10"

MATERIALS Hand-hammered stainless steel
Wooden Frame

FEATURES Hand-hammered triangular jingles for an extra sweet sound with short sustain
1 row and 2 row versions

COLOUR **BK:** Black

7 SUPER-DRY STUDIO WOOD TAMBOURINES, BRASS JINGLES

SIZE 10"

MATERIALS Hand-hammered brass
Wooden frame

FEATURES Hand-hammered triangular brass jingles for extra dry sound
1 row and 2 row version

COLOUR **BK:** Black



ARTISAN EDITION TAMBOURINES

NEW!



SOLID BRASS

HOW WE MAKE IT

01 Preparing the head for the Resin powder.

02 Putting a layer Resin on the head to enable special playing techniques.



2 rows
AE-MTAH2B

NEW!

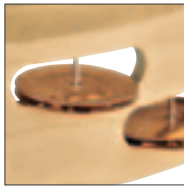

CYMBAL BRONZE



2 rows
AE-MTAH2BO

TOTAL UNIQUE TAMBOURINE SOUNDS

HEADED ARTISAN EDITION TAMBOURINES

The MEINL Headed Artisan Edition Tambourines come with a hand selected calf skin head featuring an outer ring that is prepared with Resin for special playing techniques like thumb rolls. Two different jingle versions (size and design) placed in a staggered arrangement ensure a wide sound spectrum from piano to forte and a consistent jingle sound when performing rolls.

SIZE 10"

MATERIALS Maple (*Adcer sp.*)
Hand selected calf head

B: Solid brass

BO: Cymbal bronze

- FEATURES
- Total unique tambourine sounds
 - Two different profile jingles
 - Ergonomic hand grip
 - Detailed with ornamental hot-branded logo
 - Prepared with Resin



TWO DIFFERENT PROFILE JINGLES



KONRAD GRAF, GERMANY

2



SOLID BRASS



GERMAN CYMBAL BRONZE

1 row
AE-MTA1B

2 rows
AE-MTA2B



1 rows
AE-MTA1BO

2 rows
AE-MTA2BO

3 **NEW!**



HAMMERED BRASS

COMPACT TAMBOURINE
IN HANDY SIZE

3 rows
AE-CMTA3B

NEW!



HAMMERED CYMBAL BRONZE

3 rows
AE-CMTA3BO

2 ARTISAN EDITION TAMBOURINES

MEINL Artisan Edition Tambourines are proudly made for the most discerning musicians. We developed a special profile jingle for a fine and distinct sound. The attack is airy yet punctuated, with a medium sustain. Artisan frames are precision made from pure maple wood. The hand grip is comfortable and secure.

SIZE 10"

MATERIALS Maple (*Adcer sp.*)

B: Solid brass

BO: Cymbal bronze

FEATURES Total unique tambourine sounds

Special profile jingles

Ergonomic hand grip

Detailed with ornamental hot-branded logo

3 ARTISAN EDITION COMPACT TAMBOURINES

The popular MEINL Artisan Edition Tambourines now come in a compact presentation. The size of this maple shell is 8 inches and features 3 rows of jingles with the option of solid brass jingles or German cymbal bronze jingles. The narrow jingle slots will ensure accuracy and precision when you need it.

SIZE 8"

MATERIALS Maple (*Adcer sp.*)

B: Hammered brass

BO: Hammered cymbal bronze

FEATURES Total unique tambourine sounds

Special profile jingles

Ergonomic hand grip

Detailed with ornamental hot-branded logo

3 rows of jingles

Extra narrow jingle slots for precise playing



LARRY SALZMAN, USA



COMPACT WOOD TAMBOURINES



NICKEL SILVER PLATED STEEL



2 rows
CTA2S-BK



STEEL / SOLID BRASS



2 rows
CTA2M-BK



SOLID BRASS



2 rows
CTA2B-BK



HAND-HAMMERED STAINLESS STEEL



2 rows
CSTA2S-BK



HAND-HAMMERED BRASS



2 rows
CSTA2B-BK



THE HAND-HAMMERED JINGLES BRING A TRASHY FLAVOUR TO YOUR RHYTHM

COMPACT WOOD TAMBOURINES

Good sounds comes in small packages! MEINL Percussion offers a great line of Compact Wood Tambourines. Light, fast, and full of sound, they are available in five different versions.

SIZE 8"

MATERIALS Wooden frame

CTA2S-BK: Steel

CTA2M-BK: Steel / solid brass

CTA2B-BK: Solid brass

CSTA2S-BK: Hand-hammered stainless steel

CSTA2B-BK: Hand-hammered brass

FEATURES Compact size

Many jingle variations

COLOUR **BK:** Black

SEE THE DIFFERENCE !!!

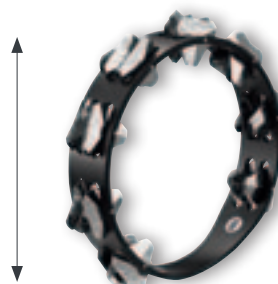

Regular tambourine size 10", 16 pairs of jingles!

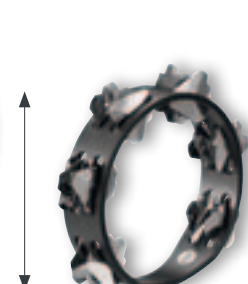

Compact tambourine in handy size 8", 12 pairs of jingles!

THE 8" DIAMETER MAKES THEM VERY COMPACT AND HANDY

HAND HELD ABS TAMBOURINES

1



NICKEL SILVER
PLATED STEEL

TMT1BK



NICKEL SILVER
PLATED STEEL

TMT1R

2



ALUMINUM

TMT1A-WH



ALUMINUM

TMT1A-B

3



STEEL / SOLID BRASS

TMT1M-WH

4



SOLID BRASS

TMT1B-BK

5



HAND-HAMMERED
STAINLESS STEEL

STMT1S-BK

6



HAND-HAMMERED
BRASS

STMT1B-BK

HAND HELD ABS TAMBOURINES

The MEINL hand held ABS Tambourines come with a padded ergonomic soft grip and are extremely light weight for long term playing comfort. Several jingle variations offer sounds ranging from dry and cutting to sweet and soft, helping every drummer find the right flavor for their rhythms.

FEATURES Padded soft grip for more playing comfort
Ergonomic design
Guiro style playing surface
"Sandwich" construction

1 TRADITIONAL TAMBOURINES, STEEL JINGLES

MATERIALS Nickelsilver plated steel
ABS plastic
COLOURS **BK:** Black
R: Red

2 TRADITIONAL ABS TAMBOURINES, ALUMINUM JINGLES

MATERIALS Aluminum
ABS plastic
COLOURS **B:** Blue
WH: White

3 RECORDING-COMBO ABS TAMBOURINE, DUAL-ALLOY JINGLES

MATERIALS Nickelsilver plated steel and solid brass
ABS plastic
COLOUR **WH:** White

4 TRADITIONAL ABS TAMBOURINE, BRASS JINGLES

MATERIALS Solid brass
ABS plastic
COLOUR **BK:** Black

5 SUPER DRY STUDIO ABS TAMBOURINE, STAINLESS STEEL JINGLES

MATERIALS Hand-hammered stainless steel
ABS plastic body
COLOUR **BK:** Black

6 SUPER DRY STUDIO ABS TAMBOURINE, BRASS JINGLES

MATERIALS Hand-hammered brass
ABS plastic body
COLOUR **BK:** Black



CHRIS COLEMAN, USA



JEAN PAUL GASTER, USA



TREVOR LAWRENCE JR., USA

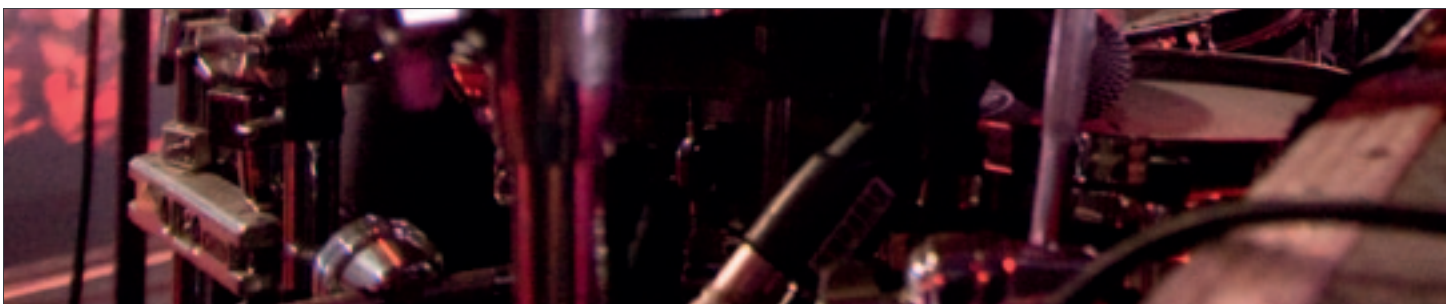

MAKE YOUR HATS GO CHING

KJ Sawka (Pendulum) uses a Professional Hihat Tambourine for special accents.



NORMAN BONINK, NETHERLANDS



FLO DAUNER, GERMANY



THOMAS LANG, AUSTRIA





MOUNTABLE ABS TAMBOURINES



MOUNTABLE ABS TAMBOURINES

The MEINL mountable ABS Tambourines are built to stand up to the heaviest of hitters. They are easily mounted on a rod or stand to complete a drummer's setup. Several jingle variations offer sounds ranging from dry and cutting to sweet and soft, helping every drummer find the right flavor for their rhythms.

- FEATURES**
- Easily mountable
 - Ergonomic design
 - Guiro style playing surface
 - "Sandwich" construction

1 TRADITIONAL ABS TAMBOURINE, STEEL JINGLES

MATERIALS Nickelsilver plated steel
ABS plastic
COLOURS **BK:** Black
R: Red

2 TRADITIONAL ABS TAMBOURINE, ALUMINUM JINGLES

MATERIALS Aluminum
ABS plastic
COLOUR **B:** Blue

3 RECORDING-COMBO ABS TAMBOURINE, DUAL-ALLOY JINGLES

MATERIALS Steel / solid brass
ABS plastic
COLOUR **WH:** White

4 TRADITIONAL ABS TAMBOURINE, BRASS JINGLES

MATERIALS Solid brass
ABS plastic
COLOUR **BK:** Black

5 SUPER-DRY ABS STUDIO TAMBOURINE, STAINLESS STEEL JINGLES

MATERIALS Hand-hammered stainless steel
ABS plastic
COLOUR **BK:** Black

6 SUPER DRY STUDIO ABS TAMBOURINE, BRASS JINGLES

MATERIALS Hand-hammered brass
ABS plastic body
COLOUR **BK:** Black

HIHAT TAMBOURINES & JINGLE STICKS

TAMBOURINES

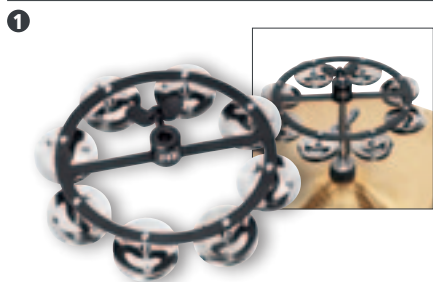

1 row
HTHH1BK

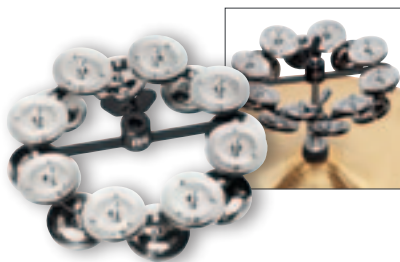

2 rows
HTHH2BK



1 row
HTHH1B-BK

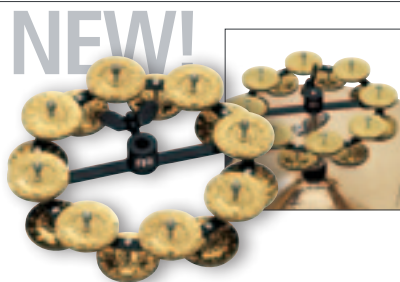

2 rows
HTHH2B-BK

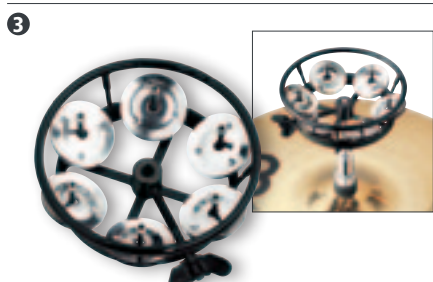

1 row
THH1BK



1 row
THH1B-BK



Steel /
Solid brass
MJS1BK

JINGLES MOUNTED ON TWO INTERSECTING PLANES



Steel
HJS1BK



Steel
HJS1R



Steel
JG1BK



Steel
JG1R



Aluminum
JG1A-B



Steel / Solid brass
JG1M-WH



Solid brass
JG1B-BK

HIHAT TAMBOURINES 1 2 3

An easy access wing nut allows quick set-up, adjustment, or removal, completely independent from your cymbals. The Professional Hihat Tambourines feature a sturdy rubberized striking ring for special accents.
size 5"

1 HEADLINER® SERIES HIHAT TAMBOURINES

MATERIAL Steel

2 HEADLINER® SERIES HIHAT TAMBOURINES

MATERIAL Hammered brass

3 PROFESSIONAL SERIES HIHAT TAMBOURINES

MATERIALS **THH1BK**: Steel
THH1B-BK: Solid brass
FEATURE Rubber padded surface

4 MULTI-JINGLE STICK

The MEINL Multi-Jingle Stick steps out into a new dimension. Steel and solid brass jingles are mounted on two intersecting faces and a single handle, for multi-directional dynamics. This opens up many new combinations of movement and sound.

MATERIALS ABS plastic

Steel and solid brass

FEATURES Jingles mounted on two intersecting planes
Padded grip
Special playing techniques

5 HEADLINER® SERIES JINGLE STICKS

The MEINL Headliner® Series Jingle Sticks are an affordable alternative to a tambourine. Nice sound effects are also achieved when used as a stick on a drum.

MATERIALS Nickelsilver plated steel
ABS plastic

COLOURS **BK**: Black
R: Red

6 PROFESSIONAL SERIES JINGLE STICKS

The MEINL Professional Jingle Sticks create many interesting sound possibilities.

MATERIALS ABS plastic

JG1: Nickelsilver plated steel
JG1A: Aluminum
JG1M: Steel solid brass
JG1B: Solid brass

FEATURES Padded grip
Guiro style playing surface



HOW WE MAKE IT

COWBELLS

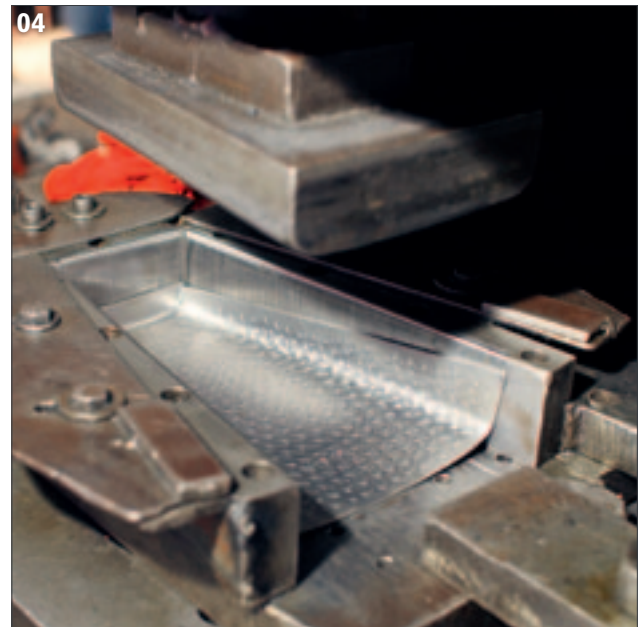
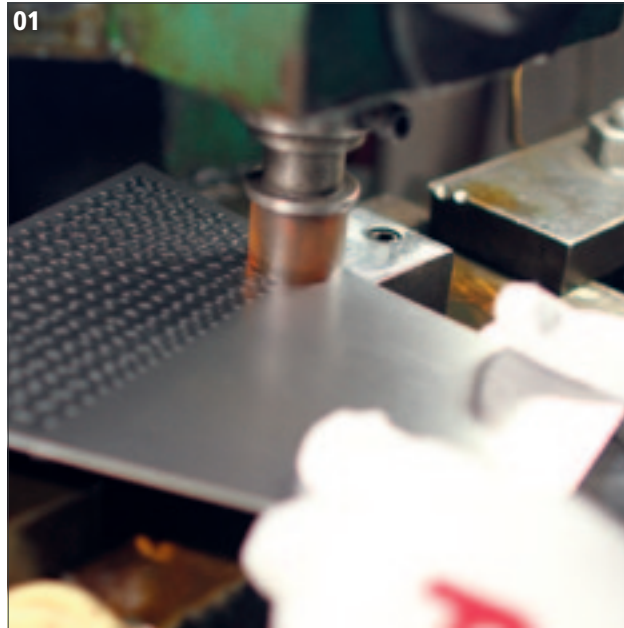

01 Cowbells are made in two halves. Here you see one side getting its hammered texture for an extra dry sound.

02 The MEINL logo is then stamped in the proper place.

03 The corners have to be cut out so the flat blank can be shaped into a cowbell.

04 A press forms the bell halves into shape.

05 Excess material is trimmed away.

06 The welds are brushed clean in preparation for the finish.

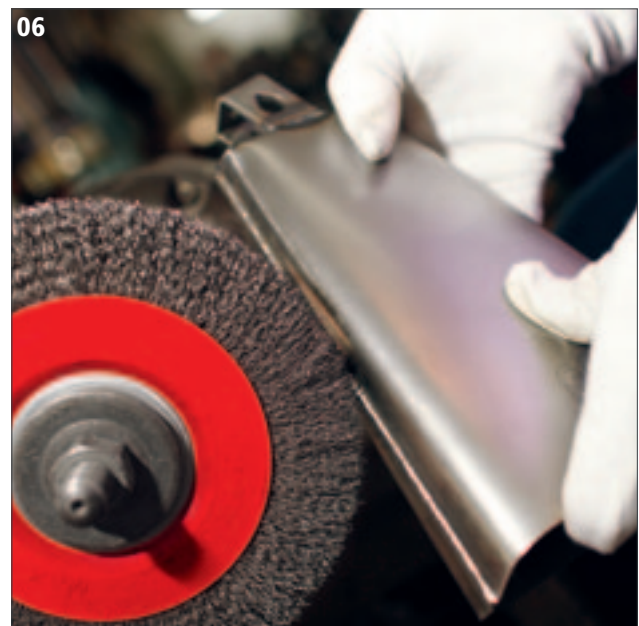

WE USE A DEEP PENETRATING AUTOMATIC FEED WELDING PROCESS FOR A SUPER STRONG SEAM.



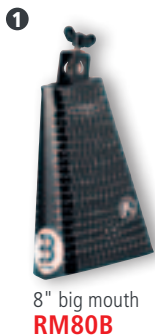

ADJUSTABLE INTERIOR
DAMPENING MECHANISM

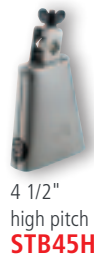

1 ARTIST SERIES COWBELL (RUSS MILLER)
The Russ Miller "Multi-Bell" enables multiple tones and is a breakthrough in versatility. You can adjust the amount of ring to your desired level with just a turn of a knob. This innovation brings out the most in a cowbell!
MATERIAL Special steel alloy
FEATURES Adjustable interior dampening mechanism
Hammered
FINISH Hand brushed black

2 ARTIST SERIES COWBELLS (KENNY ARONOFF)
Kenny Aronoff says: "my signature cowbells are the ultimate drummer's bells. Playing live they cut through and have very nice tones. Their recording characteristics are outstanding, too."
MATERIAL Special steel alloy
FEATURE Hammered
FINISH High polished chrome

3 HAMMERED COWBELLS
The strong fundamental tone of these cowbells make them a unique alternative to all other bells on the market. Each bell has its own character.
MATERIAL Special steel alloy
FEATURE Hammered
FINISHES Hand brushed copper, gold & steel

4 5 CHROME & STEEL FINISH COWBELLS
The pitches of these cowbells form a diatonic scale which makes it easy to use multiple bell combinations in any musical setting.
MATERIAL Special steel alloy
FEATURE Tonally matched
FINISHES **CH**: High polished chrome
Hand brushed steel



6

8 1/2" **SL850-BK** 6 3/4" **SL675-BK** 5 1/4" **SL525-BK** 4 3/4" **SL475-BK**



RODNEY HOLMES, USA

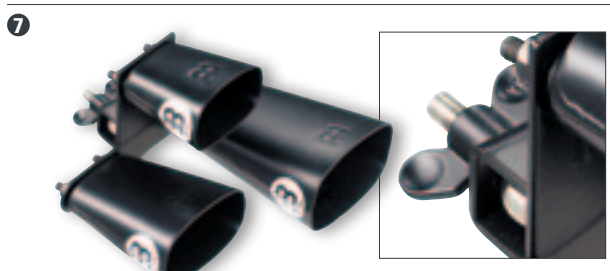

7

2 1/2", 3 1/2", 5" **SLTRI-BK**

EASY MOUNTABLE

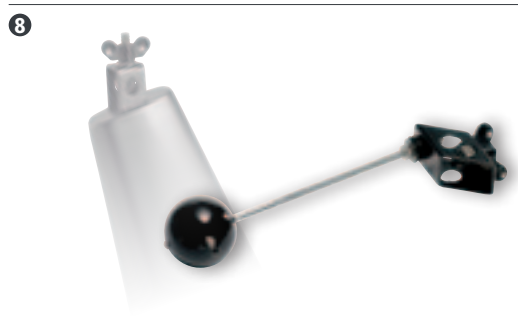

8

HAM1BK

EASY MOUNTABLE



9

8" **HCO2BK** 5" **HCO4BK**

BLACK POWDER COATED STEEL



10

High pitch **MPE1BK** Low pitch **MPE2R**



11

8.15" **STB815H** 7.85" **STB785H** 6.5" **STB65H**

SPECIAL STEEL ALLOY



12

6 1/4" **STB625HA-CB** 4 1/2" **STB45HA-CB**

COMFORTABLE HOLDER

6 7 BLACK FINISH COWBELLS & TRIPLE BELL
 Their black powder coated steel produces a firm muffled sound.
MATERIAL Special steel alloy
FEATURE Muffled sound
FINISH Black powder coated steel

8 HANDMATE
 The MEINL Handmate is a professional cowbell beater which can be mounted in a set-up. This allows hitting the cowbell by hand while playing another instrument.
MATERIAL Steel construction with a wooden ball
FEATURE Fully adjustable

9 HEADLINER® SERIES COWBELLS
 Made from black powder coated steel, the MEINL Headliner® Series Cowbells produce a cutting and sharp sound. Whether used in a percussion setup or

in a drum set configuration, they always add a special flavour to your groove.
MATERIAL Black powder coated steel
COLOUR **BK:** Black

10 PERCUSSION BLOCKS
 The MEINL Percussion Blocks are made to withstand even the hardest hitting players.
MATERIAL PE
FEATURES **MPE1BK:** High pitched sound and durability
MPE2R: Low pitched sound and durability
INCLUDES Mounting Clamp
COLOURS **BK:** Black
R: Red

11 HAND COWBELLS
 These cowbells easily cut through any high volume environment and are comfortable to hold due to their handy shape.
MATERIAL Special steel alloy
FINISH Hand brushed steel

12 HANDHELD COWBELLS
 The unique feature of the MEINL Handheld Models is a wide and comfortable grip. Ideal for street percussion.
MATERIAL Special steel alloy
FEATURE Comfortable holder
FINISH Hand brushed steel

BILL SARAGOSA LINE



BILL SARAGOSA, NOT FROM THIS WORLD

1



CONE

2



BOWL

3



TRIL

4



FILLED WITH WATER

GALAXY

5

NEW!



INVENTOR: MARCUS RALPH DE MOWBRAY



VERY FUNKY

CRASHER

BILL SARAGOSA LINE 1 2 3 4

Instruments created by Bill Saragosa are very unique.

MATERIAL Special steel alloy

FEATURE Wide sound spectrum

FINISH Black nickel

1 CONE-STACK

FEATURE A set of two

2 HELIX BOWL (US patent)

INCLUDES Metal beater

3 LIQUID TRIANGLE

INCLUDES Metal beater

4 GALAXY

INCLUDES Metal beater

5 TURBO CRASHER

The new MEINL Turbo Crasher will be a must for drummers and percussionists of all genres who want to add a different colour to their set up. This percussion accessory can be placed on any rod and will give you a nice short crashing sound.

MATERIAL Steel

FEATURES Güiro style playing surface

Cutting sound

Easy mountable

6 STAND ALONE BELL TREE

The MEINL Bell Tree has 27 solid brass bells mounted on a sturdy metal stand.

MATERIAL Solid brass bells

FEATURE Adjustable metal stand

INCLUDES Striker

7 HAND HELD BELL TREE

Our Hand Held Bell Tree has a cascade of 14 solid brass bells securely mounted on a wooden handle.

MATERIAL Solid brass bells

INCLUDES Striker

8 WAH-WAH TUBES

The MEINL Wah-Wah Tube is a tubular effect instrument that delivers smooth, bell like tones.

SIZES Small (high pitch)

Large (low pitch)

MATERIAL Aluminum

INCLUDES Rubber mallet

COLOUR **BK**: Black



27 bells
BT27



14 bells
BT14



Large (low pitch)
WW2BK

Small (high pitch)
WW1BK

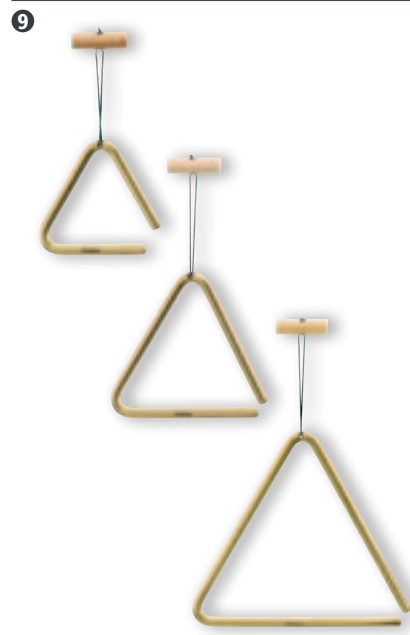

4"
TRI10B

6"
TRI15B

8"
TRI20B



7"
JCTRI20



INVENTOR: JOSÉ J. CORTIJO



PFICY-2



FICY-2

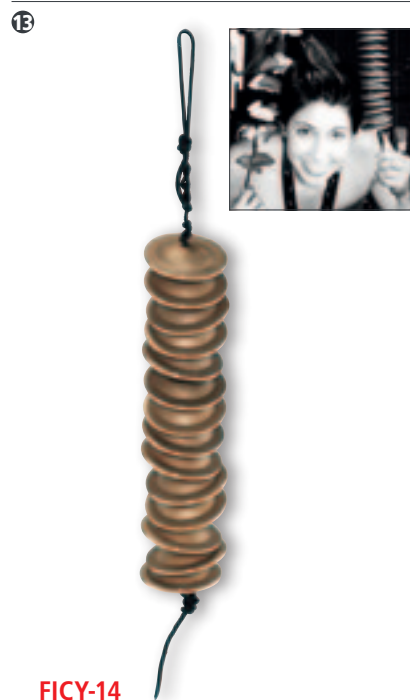

FICY-14

MARCIE CHAPA, USA

SPECIAL BRONZE ALLOY

9 TRIANGLES

The solid brass triangles produce a nice sounding soft tone with a controlled sonic spectrum.

SIZES 4", 6", 8"

MATERIAL Solid brass

INCLUDES Wooden holder with braided nylon cord
Metal beater

10 ARTIST SERIES UNIVERSAL TRIANGLE (JOSÉ J. CORTIJO)

The Universal Triangle is forged from one single piece of steel with a special texture for rasping effects.

SIZE 7"

MATERIAL Chrome plated steel

FEATURES Inner section for multiple tones
Textured leg for rasping strokes

INCLUDES Wooden holder with braided nylon cord
Metal beater

11 PROFESSIONAL FINGER CYMBALS

Made from a special bronze alloy and attached with a durable cord.

SIZE 2 5/8" diameter

MATERIAL Special bronze alloy

FEATURES Identical, high pitched sound
Durable cord

12 ORIENTAL FINGER CYMBALS

Measuring 2 3/8" in diameter, they are easy to hold and comfortable to play.

SIZE 2 3/8" diameter

MATERIAL Special bronze alloy

FEATURES Identical in pitch
Durable rubber band connection

13 HANGING FINGER CYMBALS

Strung on a durable cord and made from a special bronze alloy, 14 unique finger cymbals produce a shimmering chorus effect.

SIZE 2 3/8" diameter

MATERIAL Special bronze alloy

FEATURES Durable cord and shimmering sound

1

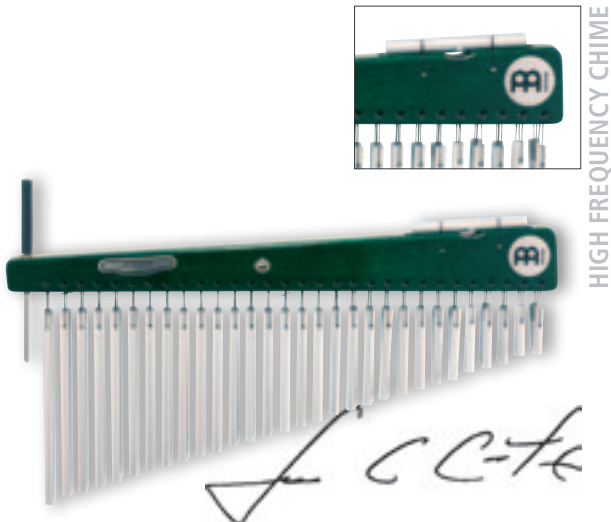

HIGH FREQUENCY CHIME

60 bars, double row
LC60HF



LUIS CONTE, USA

2



ALL BARS ARE ATTACHED THROUGH A NYLON CORD

66 bars, double row
CH66HF

3

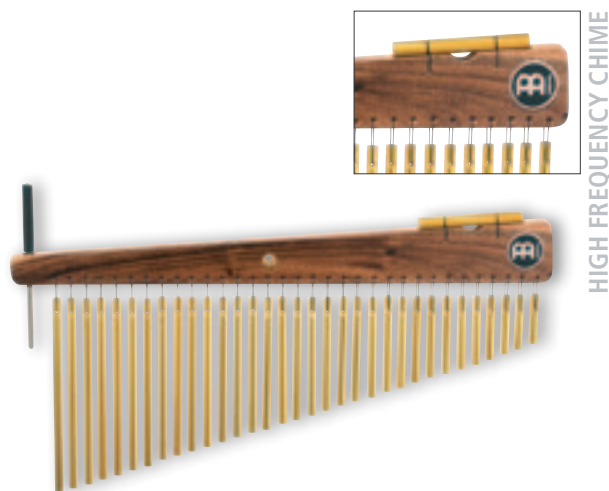

HIGH FREQUENCY CHIME

33 bars, single row
CH33HF

MEINL Chimes provide great tonal effect and are available in a wide assortment of sounds. All MEINL Chimes are made from a premium anodized aluminum alloy, and a well balanced wooden bar. Durable nylon cord is used to hang them securely.

1 ARTIST SERIES CHIMES (LUIS CONTE)

"I wanted a wide spectrum!" comments Luis Conte. "The shorter bars deliver great high pitched sounds. I can get a full and bright chime sound from the medium and low pitched bars. They sound perfect especially in the studio."

- SIZE** 60 bars, double row
- MATERIAL** Silver anodized aluminum alloy
- FEATURE** High frequency chime
- INCLUDES** Holder
Striker
- COLOUR** Green

2 CHIMES, 66 BARS

The 66 bar chimes produce a rich and full sound. They cut through any band setting.

- SIZE** 66 bars, double row
- MATERIAL** Gold anodized aluminum alloy
- FEATURE** High frequency chime
- INCLUDES** Holder
Striker

3 CHIMES, 33 BARS

The 33 bar chimes produce a very bright sound with a pronounced upper overtone spectrum. They are perfect for all live situations.

- SIZE** 33 bars, single row
- MATERIAL** Gold anodized aluminum alloy
- FEATURE** High frequency chime
- INCLUDES** Holder
Striker

4 VINTAGE CHIMES, 27 BARS

The 27 bar Vintage Chimes is an excellent addition to any drum or percussion arrangement.

- SIZE** 27 bars, single row
- MATERIAL** Silver anodized aluminum alloy
- COLOUR** **VWB**: Vintage Wine Barrel

5 VINTAGE CHIMES, 33 BARS

The 33 bar Vintage Chimes can be used in a wide range of musical styles, producing a sweet sparkling sound.

- SIZE** 33 bars, single row
- MATERIAL** Silver anodized aluminum alloy
- INCLUDES** Holder
Striker
- COLOUR** **VWB**: Vintage Wine Barrel

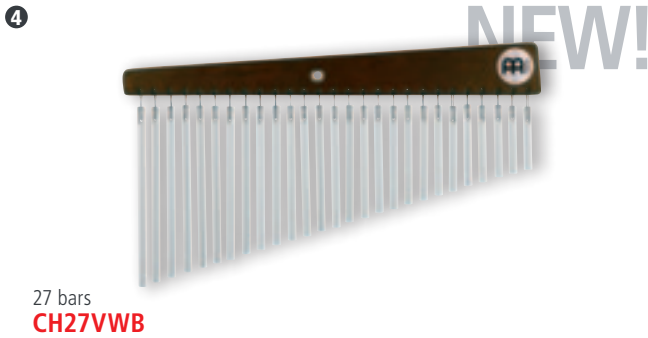

27 bars
CH27VWB



33 bars
CH33VWB



27 bars
HCH1R



33 bars
HCH2BK



12 bars, single row
CH12



27 bars, single row
CH27ST



27 bars, single row
CH27



12 bars **CH-H12** 18 bars **CH-H18** 24 bars **CH-H24**

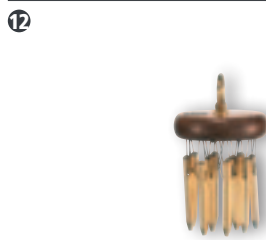

12 pegs
CH-HPEG



CH3

⑥ HEADLINER® SERIES CHIMES, 27 BARS

The MEINL Headliner® Series Chimes are a great and affordable addition to any percussion set-up! They are made from high quality materials and produce a full and warm chime sound.

SIZE 27 bars

MATERIAL Silver anodized aluminum alloy

COLOUR **R:** Red

⑦ HEADLINER® SERIES CHIMES, 33 BARS

This chime has 33 silver-anodized bars for a full sound spectrum. The curved black truss beam and the silver bar chimes look great in any percussion setup.

SIZE 33 bars

MATERIAL Silver anodized aluminum alloy

COLOUR **BK:** Black

⑧ CHIMES, 12 BARS

The 12 bar chimes produce a beautiful, high pitched sound. Not too obtrusive, ideal for tasteful chime accents.

SIZE 12 bars, single row

MATERIAL Gold anodized aluminum alloy

⑨ STUDIO CHIMES, 27 BARS

The Studio Chimes feature slightly thinner bars for a full, rich and delicate sound.

SIZE 27 bars, single row

MATERIAL Gold anodized aluminum alloy

⑩ CHIMES, 27 BARS

The 27 bar chimes produce a full sound with a wide tonal spectrum. Ideal for smaller stages and club scenes.

SIZE 27 bars, single row

MATERIAL Gold anodized aluminum alloy

⑪ HAND CHIMES

The three models of hand chimes are tonally matched.

SIZES 12 bars, 18 bars, 24 bars

MATERIAL Gold anodized aluminum alloy

⑫ PEG CHIMES

The Peg Chimes are extremely high pitched. They are perfect for special accents.

SIZE 12 pegs

MATERIAL Gold plated steel

⑬ TRI TONE CHIMES

The three free-floating bars create a very long sustain and are tonally matched.

MATERIAL Gold anodized aluminum alloy

FEATURE Mountable on all common L-roads

INCLUDES Wooden beater and holder



CABASAS, SLEIGH BELLS, GÜIRAS & BLOCKS

1  **CA7R** ADJUSTABLE NET FOR VARIOUS TENSIONS AND SOUND OPTIONS

2  **Large CA5BK-L** **Medium CA5BK** **Small CA5BK-S** PORTS FOR MORE VOLUME (PATENTED)

3  **25 bells SLB25** **12 bells SLB12** **7 bells SLB7** STEEL BELLS

4 **NEW!**  **Small MGU2** **Large MGU1** COMES WITH SCRAPER



5  **Large PMWB1-L** **Medium PMWB1-M** WELL DEFINED FUNDAMENTAL SOUND

6  **Large MWB2BK** **Medium MWB1BK** ROUNDED PLAYING SURFACE

1 CABASA, FIBERGLASS
The shape and function of the MEINL Fiberglass Cabasa equals a traditional gourd calabash.
MATERIAL Premium fiberglass
COLOUR **R:** Red

2 TURBO CABASAS (PATENTED)
The MEINL Turbo Cabasas are a great innovation, with significantly more volume than normal cabasas.
SIZES Small, medium, large
MATERIALS Steel chain and stainless steel cylinder
Wooden handle with padded soft grip
FEATURE 5 sound ports on each side for more volume (CN, DE, US patent)
COLOUR **BK:** Black

3 SLEIGH BELLS
The MEINL Sleigh Bells ring rich and full, for a true sleigh bell sound. A positive, ergonomic grip assures dynamic control.
SIZES 7, 12, 25 bells
MATERIALS Steel bells
Wooden handle
FEATURES Ergonomic grip
True sleigh bell sound

4 MERENGUE GÜIRAS
Our Merengue Güiras are robust with a precision-formed scraping surface.
SIZES Small, Large
MATERIAL Brushed steel
FEATURES Scraping surface with uniform raised bumps
One-piece metal grip with welded flanges
INCLUDES Scraper

5 PROFESSIONAL WOOD BLOCKS
Our Professional Wood Blocks are topped with Rosewood for a sharp, well defined fundamental sound.
SIZES Medium, Large
MATERIALS Rosewood top
Rubberwood body
(*Hevea brasiliensis* Muell.-Arg.)
FEATURES Well defined fundamental sound
FINISH Natural, matte

6 WOOD BLOCKS
The two versions of the MEINL Wood Blocks are tonally matched.
MATERIAL Rubber Wood
(*Hevea brasiliensis* Muell.-Arg.)
FEATURE Rounded playing surface
INCLUDES Wooden beater
COLOUR **BK:** Black, matte

CASTANETS & KALIMBAS



JUAN CARLOS MELIAN, SPAIN



Traditional
FC1

Concert
FC2



Traditional
HC1



Small
KA5-S

Medium
KA7-M-BK

Medium
KA9-M



EXTRA WIDE TONGUES
FOR COMFORT



Medium
KA9WW-BK

WIDE OPENING FOR GREAT
WAH-WAH EFFECTS

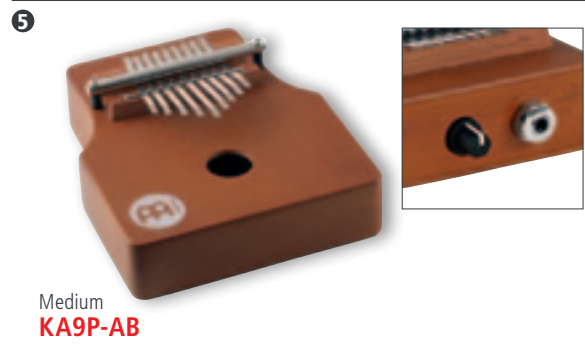

Medium
KA9P-AB

PICKUP SYSTEM WITH
VOLUME CONTROL
FROM Shadow

1 FINGER CASTANETS
Traditional Castanets are made in the style of southern Italian Tammurriata castanets.
SIZES **FC1:** Traditional
FC2: Concert
MATERIAL Rosewood (*Dalbergia sissoo*)
FEATURE Full and cutting resonance

2 TRADITIONAL HAND CASTANET
Traditional Hand Castanets are perfect for easy pick up and rapid, staccato play.
SIZE Traditional
MATERIAL Rosewood (*Dalbergia sissoo*)
FEATURES Balanced handle
Precisely formed contours for clear, distinct sound

3 SOLID KALIMBAS
The sound is pure joy, and a great addition to any percussion kit.
SIZES **KA5-S:** Small – g# f' c" f' f" c'''
KA7-M-BK: Medium – e' g d" e' c' a'
KA9-M: Medium – a' c" c' a' A f' e' e" b'
MATERIALS Chrome plated steel
Rubber Wood
(*Hevea brasiliensis* Muell.-Arg.)
FEATURES Ergonomic shape
KA7-M-BK: Extra wide tongues for comfort

4 WAH-WAH KALIMBA
You can create a great wha-wah effect by simply bouncing the kalimba body on and off your belly as you play.

SIZE Medium – a' c" c' a' A f' e' e" b'
MATERIALS Chrome plated steel
Rubber Wood
(*Hevea brasiliensis* Muell.-Arg.)
FEATURE Wah-wah effect
COLOUR **BK:** Black

5 PICKUP KALIMBA
The internal pre-amp means you won't have to worry about playing up close to the mike. An external volume knob lets you easily adjust to any situation.
SIZE Medium – a' c" c' a' A f' e' e" b'
MATERIALS Chrome plated steel
Rubber Wood
(*Hevea brasiliensis* Muell.-Arg.)
FEATURES Pickup system with external volume control
Wah-wah effect
COLOUR **AB:** African Brown

1



CL1HW



CL1RW

2

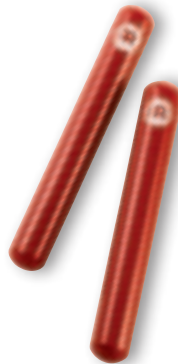

Fiberglass
CL7R

FIBERGLASS PRODUCES THE LOUDEST AND MOST CUTTING SOUND OF ALL

3



CL18

MADE FROM SUPERB,
DENSE HARDWOOD

4



CL4BK

NEW!

AFRICAN
BLACKWOOD

5



CL2HW



CL2RW



CL3HW



CL3RW



1 WOOD CLAVES, CLASSIC

The MEINL Classic Wood Claves are the most common claves and produce the classic cutting sound.

MATERIALS HW: Hardwood

RW: Redwood

FEATURE Solid body

2 FIBERGLASS CLAVES

Claves made from fiberglass produce the most penetrating, loud, and cutting sound of all.

MATERIAL Premium fiberglass

FEATURES Solid body

Cutting sound

COLOUR R: Red

3 CLAVES DE LUXE

Our Claves De Luxe are made from a superb, dense hardwood which delivers a cutting and bright tone.

SIZE 6 3/4" long

MATERIAL Dense hardwood

FEATURES Cutting sound

Convenient carrying

4 PROFESSIONAL SALSA CLAVES

The MEINL Professional Salsa Claves are made out of a high density wood that allows these instruments to have a loud sound that will cut through the ensemble in live situations. They have a high pitch and are very durable.

MATERIAL African Blackwood

FEATURES Solid body

Cutting sound

5 WOOD CLAVES, AFRICAN

African Claves are slightly larger and have a lower fundamental pitch. Additionally, the resonating body is larger than the striker. Available in two different versions: Solid and hollowed out body.

MATERIALS HW: Hardwood

RW: Redwood

FEATURES CL2: Solid body

CL3: Hollowed out body

SOUND EFFECTS

1



BI7RY

WA7BK



BI1NT

WA1NT



BI2NT

WA2NT

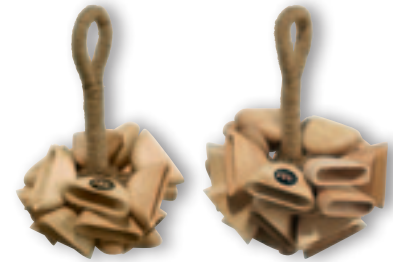

2



FR1NT

4



KO1AM

ERGONOMICALLY SHAPED HANDLE

5

IMPROVED!



RO3BK

3



NI1AM



KO2AM/BK

1 BIRDS/WATERFALL

The MEINL Birds and Waterfall realistically imitate the sound of a flock of birds or a rippling waterfall. Fiberglass and wooden versions available.

MATERIALS BI7RY, WA7BK: Premium fiberglass
BI1NT, WA1NT, BI2NT, WA2NT:
Rubber Wood
(*Hevea brasiliensis* Muell.-Arg.)

COLOURS NT: Natural
BK: Black
RY: Red/Yellow

2 FOOT RATTLE

The Foot Rattle goes with everything. Marks pulse with moderate volume and warmth.

MATERIAL Rubber Wood
(*Hevea brasiliensis* Muell.-Arg.)

FEATURE Hook and loop fastener
COLOUR NT: Natural

3 THE NIGHT

When playing The Night, four solid steel balls hit a cylindrical metal rod in quick succession producing the unique sound of crickets.

MATERIALS Solid steel balls and cylinder
Wooden body

FEATURE Ergonomically shaped handle
COLOUR AM: Amber

4 KOKIRIKOS

The Kokiriko originated in Japan as a sound effect instrument. It produces a rattling effect which can be an almost silent rustling to an extremely loud catter.

MATERIAL Wood
FEATURES KO1AM: Ergonomically shaped handle
Durable cord
KO2AM/BK:

Ergonomically designed handgrips
Wide, stable binding strap in real leather
COLOURS AM: Amber
AM/BK: Amber/Black

5 THE ROAR

A rattling effect is achieved by striking the ball end against the palm of the hand.

MATERIALS Wood
FEATURE Rattling sustain

1

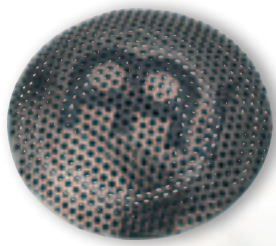

Spark shaker
SH16

CIRCULAR MOTION
ENABLES A UNIQUE
RATTLING



INVENTOR: BILL SARAGOSA

2



Spin spark
SH17

SCREW-MOUNTED DISC
ENABLES A TUNABLE
PITCH

3



Clamshell spark, set of two
SH22

HIGH PITCH & LOW PITCH

4



Headed spark
SH18

SENSATIONAL EFFECTS ARE PRODUCED WHEN
COMBINED WITH ANOTHER SPARK SHAKER

1 ORIGINAL SPARK SHAKER

The sparkling, chirping, splashing tones readily mix with almost any musical flavour. The pod-like shape fits easily into the hand and may be manipulated for many interesting effects. Spark Shakers may be played in pairs, or in combination with other shakers for even more variations.

SIZE Medium

MATERIALS Shaker: Coated steel
Pellets: Coated steel

FINISH Black nickel

2 SPIN SPARK SHAKER

The MEINL Spin Spark Shaker is equipped with a screw-mounted disc that adjusts and amplifies the characteristics of the fundamental pitch. When the disc is tight, the pitch is highest; and it deepens as

the disc is loosened. There is a distinctively pleasant supplemental timbre.

SIZE Medium

MATERIALS Shaker: Coated steel
Pellets: Coated steel

FINISH Black nickel

3 CLAMSHELL SPARK SHAKERS

Clamshell Spark Shakers have a single solid weld holding the two halves of the shell together like a hinge. When you squeeze the two halves together, you get a wildly variable pitch response. It comes in two pitches, for high-low combinations.

MATERIAL Steel

FEATURES Comes in a set of two
Wildly variable pitch response

FINISH Black nickel

4 HEADED SPARK SHAKER

One side of the MEINL Headed Spark Shaker is a drum head! Premium goatskin and a steel shell provide a rattling combination of crisp warm tones and a bright metal timbre.

SIZE Medium

MATERIALS Shaker: Coated steel
Pellets: Coated steel

Goat head

FEATURES Swirling effect

Variable pitch

FINISH Black nickel

ARTIST SERIES & STUDIOMIX SHAKERS

1



LUIS CONTE, USA

Luis Conte

SOFT STUDIO

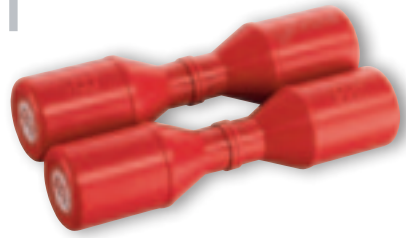

Studio shaker, red
SH5R



MED LIVE



Live shaker, black
SH4BK



LOUD STADIUM



Stadium shaker, grey
SH45GR



2



Large
SH12-L-BK



Medium
SH12-M-BK

1 ARTIST SERIES SHAKERS (LUIS CONTE)

The three versions have been designed according to master percussionist Luis Conte's exact requirements. "My shaker sound is as smooth as silk" is how Luis described their sound.

- SIZE Medium
- MATERIAL Plastic
- FEATURE Two individual shakers connected as one instrument
- COLOURS **SH4BK** (Live Shaker): **BK**: Black
SH45GR (Stadium Shaker): **GR**: Grey
SH5R (Studio Shaker): **R**: Red

2 STUDIOMIX SHAKERS

The StudioMix Shakers have a crisp full sound and come in two sizes. The textured surface both enhances the timbre and enables a positive grip. Lightweight plastic body is virtually unbreakable.

- SIZES Medium
Large
- MATERIAL Plastic
- FEATURE Textured surface for special sound and positive grip
- COLOUR **BK**: Black



JUNIOR MORAES, BRAZIL

1



Small
SH8BK



Medium
SH88BK



Large
SH888BK



AMEL SERRA,
NETHERLANDS

2



Large
SH10-L-BK

3



Large
SH7-L-BK



Medium
SH7-M-BK

4



INVENTOR:
JUAN CARLOS MELIAN



Medium
JS88BK

BY TILTING THE SHAKER 90° TO
THE FRONT THE JINGLES START
TO CLICK ON THE BEAT

5



BLACK MAKAH-BURL

Large
SH15-L

Medium
SH15-M

Small
SH15-S

1 ALUMINUM SHAKERS, OCTAGONAL

MEINL's Octagonal Aluminum Shakers come in three different sizes. All have a broad dynamic range with lots of volume.

SIZES **SH8BK**: Small
SH88BK: Medium
SH888BK: Large

MATERIAL Aluminum
COLOUR **BK**: Black

2 STUDIO SHAKER

MEINL's Studio Shaker was designed to meet all the requirements necessary in today's session world. It delivers a very tasteful and delicate shaker sound with a warm tone and a well balanced frequency spectrum.

SIZE Large
MATERIAL Plastic
COLOUR **BK**: Black

3 FIBERGLASS SHAKERS

These MEINL Shakers are made from premium fiberglass for more durability and better sound quality. They are light weight and very comfortable to play.

SIZES **SH7-M-BK**: Medium
SH7-L-BK: Large

MATERIAL Premium fiberglass
COLOUR **BK**: Black

4 ALUMINUM JINGLE SHAKER

The MEINL Aluminum Jingle Shaker (designed by Juan Carlos Melian) has two pairs of steel jingles which are attached in one row to an octagonal aluminum shaker.

SIZE Medium
MATERIALS Shaker: Aluminum
Jingles: Steel
COLOUR **BK**: Black

5 WOOD SHAKERS

Made from a combination of selected woods, these new MEINL Wood Shakers offer a nice array of alternative sounds.

SIZES **SH15-S**: Small
SH15-M: Medium
SH15-L: Large

MATERIALS Rubber Wood
(*Hevea brasiliensis* Muell.-Arg.)
Top and Bottom: Black Makah-Burl



6



Small
SH6-S-BK

TWO DIFFERENT MATERIALS PRODUCE EXPERIMENTAL SOUNDS

7



Medium
SH20BK

BY COVERING AND UNCOVERING THE SOUND HOLE, A "WAH-WAH" EFFECT CAN BE ACHIEVED

8



Medium
SH3BK

LOUD AND PENETRATING SOUND DUE TO THE MANY HOLES

9



Large
SH9-L-S

10



Medium, black
SH21BK

Medium, grey
SH21GR

6 RAWHIDE SHAKER
The MEINL Rawhide Shaker combines two different materials into one unique instrument. It produces very experimental sounds and works perfectly in modern music productions.
SIZE Small
MATERIALS Plastic with natural rawhide side caps
COLOUR **BK**: Black

8 LOOP SHAKER (US PATENT)
The MEINL Loop Shaker has a crackling bright sound with many dynamics, and is easy to control. It is very responsive to hand pressure and movement, giving it a soft or loud voice as needed.
SIZE Medium
MATERIAL Plastic
FEATURE Loud and penetrating sound due to the many holes (US patent)
COLOUR **BK**: Black

9 ALUMINUM SHAKERS, ROUND
The MEINL Round Aluminum Shakers were designed to cut through loud live music.
SIZE Large
MATERIAL Anodized aluminum
COLOUR **S**: Silver

10 U.F.O. SHAKERS
The black MEINL U.F.O. Shaker produces an extreme mellow and smooth sound and less attack, while the grey version has a crisper sound with more volume.
SIZE Medium
MATERIAL Plastic
COLOURS **BK**: Black
GR: Grey



NATURAL RAWHIDE

Jumbo
MSM4

Traditional
MSM3

Mini
MSM2



Studio
PM1BK

Concert
PM2BK

Live
PM3BK

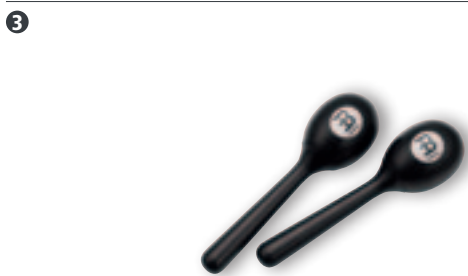

PEMBK



Oval
MWM1MC

Round
MWM2AM



MCL2BG

NEW POSSIBILITIES IN SOUNDS,
RHYTHMS, AND SHOWMANSHIP

INVENTOR:
DANY MORENO

1 RAWHIDE MARACAS

Rawhide Maracas are entirely made by hand and are offered in three different sizes for a wide sonic range.

- SIZES** **MSM2:** Mini
MSM3: Traditional
MSM4: Jumbo

MATERIALS Natural rawhide and wooden handle

2 STUDIO, CONCERT, LIVE MARACAS

This lightweight plastic maracas provide stability and a strong, projecting sound.

- MATERIAL** Plastic
FEATURE Ergonomically shaped handle
COLOUR **BK:** Black

3 PLASTIC EGG MARACAS

Made from special plastic material, the MEINL Egg Maracas have a clear and crisp tone with a comfortable handle for absolute control.

- SIZE** 6"
MATERIAL Plastic
FEATURE Ergonomically shaped handle

4 WOOD MARACAS

The traditional MEINL Wood Maracas are available in both round and oval models. Both of these exhibit a traditional warm and rich sound.

MATERIAL Wood

5 MARACLAVES

The MEINL Maraclaves are an exciting hybrid percussion instrument. They are a pairing of full volume maraca "bulbs" mounted on solid American White Ash "handles". The result is a new way to combine the two timbres inside an efficient set of movements. MEINL Maraclaves offer new possibilities in sounds, rhythms, and showmanship!

- MATERIALS** American Ash wood
(*Fraxinus americana* L.)
Plastic shaker head
FEATURES Can be played like maracas and claves at the same time
Precise and cutting sounds
Durable construction
Detailed with logo heat-branded on handle
COLOUR **BG:** Beige

HAND PERCUSSION

1

Soft Loud
Medium Extra loud

ES-SET

RANGE OF VOLUME FROM SOFT TO EXTRA LOUD

2

Blue **ES2-B** Red **ES2-R** Black **ES2-BK** Yellow **ES2-Y** Green **ES2-GREEN**

3

Jumbo, black **ESW-J-BK**

4

NEW!

Holds 60 egg shakers **ES-BOX**

5

D01 **GA2**

6

CAX1 **CAX2** **CAX3**

7

Large **FROG-L** Medium **FROG-M**

8

Plastic, black **GU6BK**

THREE PLAYING SURFACES

9

Fiberglass, black **GU7BK**

PADDED GRIP HOLES

10

Wood, african brown **GU2AB-M**

Wood, amber **GU1AM**

1 EGG SHAKER SET
Set of four Shaker Eggs fit all your needs in the studio or on the road.
MATERIAL Plastic
FEATURE Range of volume from soft to extra loud

2 PLASTIC EGG SHAKERS
MATERIAL Plastic
COLOURS **B:** Blue, **BK:** Black, **GREEN:** Green
R: Red, **Y:** Yellow
FEATURE Comes in a set of two

3 WOOD EGG SHAKER
SIZE Jumbo
MATERIAL Wood
COLOUR **BK:** Black

4 EGG SHAKER BOX
FEATURE Holds 60 egg shakers

5 DOUBLE SHAKER/GANZA
MATERIALS Rattan with coconut bottom

6 CAXIXIS
MATERIALS Rattan with coconut bottom

7 WOODEN FROGS
SIZES Medium, Large

8 PLASTIC GÜIRO
MATERIAL High strength plastic
FEATURE Three striking surfaces rubber ringed grip holes
INCLUDES Plastic Scraper
COLOUR **BK:** Black

9 FIBERGLASS GÜIRO
MATERIAL Premium fiberglass
FEATURES Three striking surfaces Padded grip holes
INCLUDES Plastic scraper
COLOUR **BK:** Black

10 WOOD GÜIROS
MATERIAL Wood
FEATURES **GU1AM:** Grip holes **GU2AB-M:** Three striking surfaces Grip holes
INCLUDES **GU1AM:** Wooden scraper **GU2AB-M:** Plastic scraper
COLOURS **AB-M:** African Brown, matte **AM:** Amber



RAINMAKER & RAINSTICKS

1



RA7BK



HOW WE MAKE IT

01 The synthetic didgeridoos are being prepared for hand painting. The black base colour is applied first.

02 Every MEINL Didgeridoo/Rainstick is a hand-painted unique piece of art.

03 You can see how much care and detail goes into each didgeridoo.

2



39"
RS1BK-L

24"
RS1R-M

16"
RS1BK-S

3



39"
SRS1R-L



1 RAINMAKER

The MEINL Rainmaker is uniquely different. Due to the circular construction, it can be mounted on a cymbal stand and by simply turning the instrument a drizzle can immediately change into the sound of a monsoon.

MATERIAL Premium fiberglass

FEATURE Circular construction

INCLUDES Ergonomically shaped handle

COLOUR **BK**: Black

2 WOOD RAINSTICKS

Natural Bamboo makes our Rainsticks pleasant effect instruments, with plenty of projection and long sustain. They may be played like big shakers as well.

SIZES 16" (40 cm)

24" (60 cm)

39" (100 cm)

MATERIAL Bamboo

COLOURS **BK**: Black

R: Red

3 SYNTHETIC RAINSTICK

The MEINL Synthetic Rainstick is light in weight and extremely durable.

SIZE 39" (100 cm)

MATERIAL Lightweight synthetic

COLOUR **R**: Red



DIDGERIDOOS

1



NEW!



47"
DDG1-BK

47"
DDG1-BR

47"
DDG1-R

2



51"
SDDG1-BK

51"
SDDG1-R

3 **NEW!**



INVENTOR: MARK ALLEN JOHNSON



8 1/2" x 5"
DDG-BOX



SMALL IN SIZE BUT BIG IN SOUND

1 WOOD DIDGERIDOOS

These Didgeridoos are a great way to get started on the oldest wind instrument in the world. It makes a distinctive drone with harmonic overtones, and goes great with all kinds of percussion. These didgeridoos are made from Bamboo.

SIZE 47" long (120 cm)

MATERIAL Bamboo

COLOURS **BK:** Black

BR: Brown

R: Red

2 SYNTHETIC DIDGERIDOOS

The MEINL Synthetic Didgeridoos are a modern twist on the traditional bamboo construction. They are extremely durable and are unaffected by weather so they are perfect for outdoor use.

SIZE 51" (130 cm)

MATERIAL Lightweight synthetic

COLOURS **BK:** Black

R: Red

3 TRAVEL DIDGERIDOO (US PATENT)

The new MEINL Travel Didgeridoo is small in size but big in sound. The zigzag design on the inside enables authentic didgeridoo sounds. Its compact size makes it the perfect instrument to take on the road or to the studio without taking too much space.

SIZE 8 1/2" x 5"

MATERIAL Mahogany Wood

FEATURE Hot-branded logo

Compact design

1



36"–62"
TSDDG1-BK



TWO TELESCOPING SECTIONS

2



57"
PROFDDG1-BK

57"
PROFDDG2-BR

ABOUT SIMON "SI" MULLUMBY

Si has developed a totally new style of playing didgeridoo. Mixing tight vocal percussive beats with deep bass grooves an awesomely textured sonic environment is created.

Within the 20 years he has been playing he has become one of the most respected didgeridoo players in the world. Si has a strong following in Australia, Japan and Europe after touring many times with his dance band Wild Marmalade. In 2004 Si became the first didgeridoo player in history to have had a contract with the world famous "Cirque du Soleil" in Las Vegas.

Si was inspired to play after a mystical experience in India where he realized that it was his life purpose to play didgeridoo. After this experience he left medical school and hitchhiked around Australia. Playing intuitively for many years Si went on to study drumming and body percussion then entering the professional arena as a didgeridoo musician.



1 TROMBONE DIDGERIDOO

The MEINL Trombone Dideridoo can vary in pitch like a slide trombone. One section has the mouthpiece and slides into the bell section. Pitch intervals are painted clearly on the side of the instrument. Hand finished with exotic Australian style dot painting.

SIZE 36"–62"

MATERIAL Premium fiberglass

FEATURES Two telescoping sections for variable pitch

Tuning from: G# G F# F E D# D C# C

COLOUR **BK:** Black

2 FIBERGLASS DIDGERIDOOS

Our Professional Didgeridoos are made from premium fiberglass for unsurpassed stability and long life. A flared bell enhances the sound projection, and the hand-painted designs make them truly beautiful.

SIZE 57" long (145 cm)

MATERIAL Premium fiberglass

COLOURS **BK:** Black

BR: Brown



ARTIST SERIES DIDGERIDOO

SIMON "SI" MULLUMBY, AUSTRALIA



NEW!

DIDGERIDOOS



61"
SDDG1-SI

ARTIST SERIES DIDGERIDOO (SIMON "SI" MULLUMBY)

"Resonant, easy to play, and good for players of all levels my Artist Series Didgeridoo has unique design features giving it incredible playability. Designed for speed playing and warmth of tone this instrument is a guaranteed win for those looking for a quality didgeridoo" comments Simon "Si" Mullumby.

SIZE 61" long (154 cm)
MATERIAL Premium fiberglass
COLOUR Grey





CANDELA PERCUSSION CYMBALS

1



16"
CA16C

14"
CA14C

2



10"
CA10S

HAND HAMMERED

3



10"
CA10PH

QUICK RESPONSE WHEN
HIT BY A HAND



1 PERCUSSION CRASHES

The crashes are thin, tonally matched cymbals which can be played by hand or hit with a stick. They respond fast and decay quickly.

SIZES 14", 16"

MATERIAL B20 Bronze

FEATURES Hand-hammered
Brilliant finish
Fast response and attack
Quick decay

2 PERCUSSION SPLASH

The percussion splash is an extremely thin, quick sounding cymbal – perfect for fast percussive accents.

SIZE 10"

MATERIAL B20 Bronze

FEATURES Hand-hammered
Brilliant finish
Fast response and attack
Quick decay

3 PERCUSSION HIHAT

A specially designed hihat just for cajon players. It can be played by hand or with lighter sticks. The top is extremely thin for a fast, controlled response. Recommended for use with the MEINL Low Hat.

SIZE 10"

MATERIAL B20 Bronze

FEATURES Can be played by hand or with lighter sticks
Recommended for use with the MEINL Low Hat



YOGI JOKUSCH, GERMANY

4



18"
CA18CR

5



BUILT-IN JINGLES

14"
CA14PJB

4 TIMBALES CRASH/RIDE

It's the perfect cymbal for timbale playing. It has a loud, penetrating bell and a full, warm crash sound.

SIZE 18"

MATERIAL B20 Bronze

FEATURES Hand-hammered

Brilliant finish

Cutting bell sound

Great crash sound

5 PERCUSSION JINGLE BELL

A great cymbal with an exotic sound. Six pairs of jingles attached to this cymbal produce a rattling effect.

SIZE 14"

MATERIAL B8 Bronze

FEATURES Precisely hammered

Built in jingles





STICKS & BEATERS & SCRAPERS

1



Black **TBRS-BK** Red **TBRS-R**

2



INVENTOR OF FDT5:
THÓRRALF SCHUUH

FDT5

3

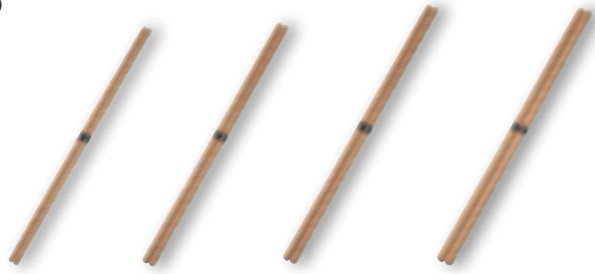

5/16" x 15" **TS5/16** 3/8" x 15" **TS3/8** 7/16" x 16" **TS7/16** 1/2" x 16" **TS1/2**



FDT4



FDT2



FDT3



FDT1

4



Long **SST1-L** Medium **SST1-R** Short **SST1-S**



Sevenfold **SST7** Sixfold **SST6** Triple **SST3** Triple short **SST3-S**

1 TAMBORIM STICKS

The MEINL Tamborim Sticks have three balanced, flexible plastic rods in a handy size.

MATERIAL Plastic
COLOURS **BK**: Black
R: Red

2 BODHRAN TIPPERS

The MEINL Bodhran Tippers come in five different styles, each with its own characteristic. They range from thin and light, to thick and full bodied. A special tipper with leather whips was designed by Thórralf Schuuh.

MATERIAL Ash Wood
COLOUR African Brown

3 TIMBALE STICKS

The MEINL Timbale Sticks are made out of the finest hand-selected Hickory Wood and are available in four different sizes.

MATERIAL Hickory Wood
SIZES **TS5/16**: 5/16" x 15",
TS3/8: 3/8" x 15",
TS7/16: 7/16" x 16",
TS1/2: 1/2" x 16"

4 SAMBA STICKS

MEINL offers a wide assortment of Samba Sticks for Tamborims, Repiniques, and other Samba instruments in order to achieve their authentic sounds.

MATERIAL Plastic
SIZES **SST1-S**: Stick, short version
SST1-R: Stick, medium version
SST1-L: Stick, long version
SST3-S: Triple stick, short version
SST3: Triple stick
SST6: Sixfold stick
SST7: Sevenfold stick

5



2" felt beater
SB1

2" felt beater
SB2

2 1/2" felt beater
SB3

2" leather beater
SB4

3" bushy felt beater
SB5

Wood beater
SB6

Two 2" felt beater
SB2-D

Two 2 1/2" felt beater
SB3-D

6



SBH

7



Rattan
SPARE-10

Mahogany Wood
SPARE-23

8



COW1

COW2

COW1BK



RIBBED GRIP

9



Wood
MGS1

ABS
MGS2

5 SAMBA BEATERS

MEINL offers a wide assortment of Samba Beaters for Surdos and Repiniques in order to achieve their authentic sounds. All beaters are made from high quality materials to assure comfortable playing.

SB1: 15" long, aluminum stick with 2" felt beater

SB2: 16" long, wood stick with 2" felt beater

SB2-D: 16" long, wood stick with two 2" felt beater

SB3: 16" long, wood stick with 2 1/2" felt beater

SB3-D: 16" long, wood stick with two 2 1/2" felt beater

SB4: 16" long, wood stick with 2" leather beater

SB5: 16" long, wood stick with 3" bushy felt beater

SB6: 16" long, wood stick

6 SURDO BEATER HOLDER

Keep your Surdo Beaters at the ready, comfortably hanging on your belt.

MATERIAL Leather

COLOUR Black

7 TALKING DRUM BEATERS

The curved playing end of the Talking Drum Beaters enables ideal positioning to strike the drum head, held near the player's body.

SPARE-10: Rattan

SPARE-23: Mahogany Wood

8 COWBELL BEATERS

MEINL offers a regular and professional cowbell beater for more sound options.

MATERIAL Rubber Wood

(*Hevea brasiliensis* Muell.-Arg.)

FEATURES Ribbed grip

Padded beater section

9 GÜIRA SCRAPERS

MEINL offers a wooden and a ABS Güira Scraper for more sound options and different playing techniques.

MATERIALS **MGS1:** Ergonomic wooden grip

MGS2: Sanded ABS grip
Steel rods

1



Black powder coated

Black powder coated
For Marathon® Classic/Designer Series
For Luis Conte Artist Series
ST-MCC11BK: 11"
ST-MCC1134BK: 11 3/4"
ST-MCC1212BK: 12 1/2"

Chrome plated



Gold tone

Chrome plated
For Floatune Series
ST-FL10CH: 10"
ST-FL11CH: 11"
ST-FL12CH: 12"
ST-FL13CH: 13"
For Professional Series
For Fibercraft Series
ST-MP11CH: 11"
ST-MP1134CH: 11 3/4"
ST-MP1212CH: 12 1/2"

Chrome plated
For Woodcraft Series
ST-WC11CH: 11"
ST-WC1134CH: 11 3/4"
ST-WC1212CH: 12 1/2"

Gold tone
For Mongo Santamaria Artist Series
ST-MSA11G: 11"
ST-MSA1134G: 11 3/4"
ST-MSA1212G: 12 1/2"

QUICK AND EASY
HEIGHT ADJUSTABILITY
(DE PATENT)

2

Black powder coated
ST-HEBK

Chrome plated
ST-HECH

Gold tone
ST-HEG



EASY AND EFFECTIVE
HEIGHT EXTENSION

3

NEW!



For Headliner®
congas
HDSTAND

NEW!



For MCC congas
TMD5

4



Chrome plated
TMC-CH

COMPATIBLE
FOR ALL SIZES!

THE LIGHTWEIGHT STAND CAN
BE FOLDED TO A COMPACT UNIT
WHICH REQUIRES LITTLE SPACE

1 STEELY II CONGA STANDS (PATENTED)

The MEINL Steely II Conga Stands are available for all MEINL Professional Series Congas.

MATERIAL Steel

FEATURES Metal spike attachment on each leg
L-shaped legs (DE, TH, US patent)
U-shaped notch for quick set up and break-down (US patent)
Ergonomic arched rubber bracing for more stability (CN, DE, US patent)
Notches for quick height adjustability (DE patent)

INCLUDES Allen wrench

2 STEELY II CONGA STAND HEIGHT EXPANDER SETS (DE PATENT)

These innovative add-ons to the MEINL Steely II Conga Stands allow an easy and effective height extension,

which provides a more comfortable playing position for taller congueros.

MATERIAL Steel

FEATURE Easy and effective height extension

INCLUDES Mounting screws

Allen wrench

FINISHES Black powder coated

Chrome plated

Gold tone

3 CONGA DOUBLE STANDS

Specially designed to hold two congas at once. It is fully height adjustable and features a memory lock for a quick set up.

MATERIAL Steel

FEATURES Height adjustable

Double braced tripod legs

INCLUDES Allen wrench

Memory locks

Brackets

Set of screws, nuts, and washers

Mounting description

4 PROFESSIONAL CONGA STAND

The Professional Conga Stand is unique with respect to design and function. It was especially developed to accommodate the rigors of professional road use, where fine adjustment and durability are demanded.

MATERIAL Chrome plated steel

FEATURES Unique design (DE, US patent)

Rubber padded crossbeams

Fully height adjustable

Folds up to a compact unit

INCLUDES Allen wrench

Memory locks

BONGO STANDS

1



Black powder coated
THBS-BK



Chrome plated
THBS

AN INNOVATIVE DESIGNED BRACKET
ENABLES QUICK SET UP (PATENTED)

2



Chrome plated
TMB

PADDED T-SHAPED TUBE FOR MORE STABILITY

3



Chrome plated
TMB-S

A STABLE METAL CLAMP HOLDS
THE ENTIRE UNIT IN PLACE

LOW HEIGHT FOR
SEATED PLAYERS

1 HEADLINER® SERIES BONGO STANDS (CN, DE, US PATENT)

These bongo stands combine easy handling and functionality with reliability and sturdy construction. A newly designed bracket enables extremely quick and easy mounting, yet holds the entire bongo securely in place.

MATERIAL Steel

FEATURES Quick set up
Easy handling
Reliable placement
Double braced tripod stand
Fits all common bongos

INCLUDES Wrench

COLOURS **THBS**: Chrome
THBS-BK: Black

2 PROFESSIONAL BONGO STAND

The MEINL Bongo Stand features a new design concept and simple functionality. The bongo is placed on a padded T-shaped tube and secured with a convenient knob screw. A stable metal clamp holds the entire unit securely in place.

MATERIAL Chrome plated steel

FEATURES Padded T-shaped tube
Fully height- and angle adjustable
Double braced tripod legs
Fits all common bongos

INCLUDES Allen wrench
Memory locks

3 PROFESSIONAL BONGO STAND FOR SEATED PLAYERS

This version of MEINL's Professional Bongo Stand has all the features of the regular model. However, it can be placed low enough to be comfortably played sitting down in the traditional position.

MATERIAL Chrome plated steel

FEATURES Seated playing position possible
Padded T-shaped tube
Fully height- and angle adjustable
Double braced tripod legs
Fits all common bongos

INCLUDES Allen wrench
Memory lock

1



Black powder coated
STDJST-BK

NEW!

COLLAPSIBLE DESIGN

2

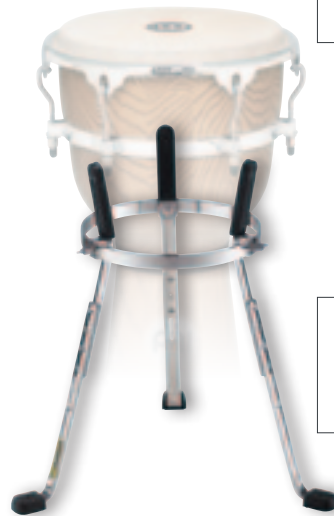

Chrome plated
ST-DJEMBE



ADJUSTABLE TO ACCOM-
MODATE VARIOUS DJEMBE
SIZES USING THREE SPACERS



QUICK AND EASY
HEIGHT ADJUSTABILITY
(DE PATENT)

3



Chrome plated
TMD



LENGTH ADJUSTABLE FOR
VARIOUS DJEMBE SIZES

4



Black powder coated
TMCAJ

NEW!

FITS FOR ALL CAJON SIZES

1 TRAVEL DJEMBE STAND

The practical design makes it perfect for drum circles.

MATERIAL Black powder coated steel

FEATURES Collapsible design
Lightweight construction

2 STEELY II DJEMBE STAND (PATENTED)

It can be adjusted to accommodate various djembe sizes using three spacers and is fully height adjustable.

MATERIAL Chrome plated steel

FEATURES Metal spike attached to each leg
L-shaped legs (DE, TH, US patent)
U-shaped notch for quick set up and break-down (US patent)
Ergonomic arched rubber bracing for more stability (CN, DE, US patent)

Notches for quick height adjustability (DE patent)

Adapts to different djembe sizes

INCLUDES Allen wrench, 3 spacers

3 PROFESSIONAL DJEMBE STAND

The MEINL Djembe Stand was designed to firmly hold any djembe in the traditional playing position.

MATERIAL Chrome plated steel

FEATURES Rubber padded hooks
Fully height- and angle adjustable
Double braced tripod legs

INCLUDES Allen wrench
Memory lock

4 PROFESSIONAL CAJON STAND

The MEINL Cajon Stand is fully adjustable and fits for all common cajon sizes.

MATERIAL Steel

FEATURES Quick set up
Fully height- and angle adjustable
Double braced tripod stand
Fits for all cajon sizes

5 HAND-BALE STAND

Our Hand-Bale Stand is double-bracketed and fully adjustable.

MATERIAL Chrome plated steel

FEATURES Quick set up
Rubber-tipped three arm basket
Easy handling
Double braced tripod stand

5



THREE-ARM BASKET HOLDS THE HAND-BALE SECURELY

Chrome plated
TMTS

6



SPECIAL LOW HEIGHT

Chrome plated
MLH

7



SPECIALLY DESIGNED TO HOLD CHIMES, NOT CYMBALS

Chrome plated
TMCH

8



Chrome plated
TMID



FOAM PADDED RING

9



Chrome plated
TMPS



DIFFERENT RODS FOR ALL NEEDS

6 LOW HAT

The Meinl Low Hat has been designed with a special low height, made just for cajon players.

MATERIAL Chrome plated steel

FEATURES Special low height
Made just for cajon players

7 CHIMES STAND

Our Chimes Stand is a fully-adjustable, double braced tripod stand, specially designed for mounting bar chimes just the way you want them to be held! Made from sturdy chrome-plated steel for dependability. Special padding eliminates unwanted movement, and rubber feet prevent slipping.

MATERIAL Chrome plated steel

FEATURES Full angle and height adjustability
Secure angle clamps
Telescoping stem

8 PROFESSIONAL DOUMBЕК/IBO STAND

This Stand was designed to enable playing an Ibo Drum or a Doumbek in ways other than simply being placed in one's lap, such as standing up or incorporating it into a percussion set up. It can be angled and is fully height adjustable.

MATERIAL Chrome plated steel

FEATURES Foam padded ring
Fully height- and angle adjustable
Double braced tripod legs

INCLUDES Allen wrench
Memory lock

9 PERCUSSION STAND

The MEINL Percussion Stand is a universal device which offers a variety of set up solutions for both drummers and percussionists. It is fully height adjustable and features both quick locks and memory locks for a quick set up.

MATERIAL Chrome plated steel

FEATURES Height adjustable
Double braced tripod legs

INCLUDES Allen wrench
Memory locks
2 straight rods
2 angled rods
2 Z-shaped rods

1 NEW!

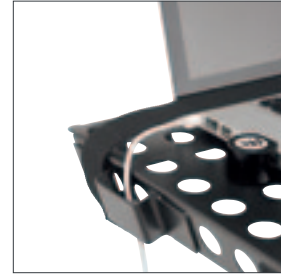

CORD STRAIN RELIEF



FIVE STOPPERS AND HOOK AND LOOP FASTENER TO SECURE THE LAPTOP

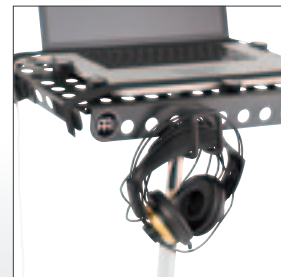

REMOVABLE HOLDER FOR HEADPHONES

20" x 12 1/2"
TMLTS

1 LAPTOP TABLE STAND

The MEINL Laptop Table Stand comes with a strap and stoppers that secure the computer to it. The perforated metal plate ensures that the laptop gets always good ventilation.

SIZE 20" x 12 1/2"

MATERIAL Perforated metal plate

FEATURES Holds laptops up to 17"

- Stoppers and hook and loop fastener to secure the laptop
- Holder for headphones
- Cord strain relief

2 PERCUSSION TABLES

These Percussion Tables are made from durable fiberglass and offer enough room for all common hand percussion instruments.

SIZES **MC-PT:** 18" x 12"

MC-PT-JB: 18" x 12"

MC-PTS: 12" x 12"

MATERIAL Premium fiberglass

FEATURES Fabric anti-slip surface

Adjustable angle

Strong mounting clamp

MC-PT-JB: Jawbreaker motif



CRISTIAN LA TORRE, CHILE

2



FABRIC ANTI-SLIP SURFACE

NEW!

12" x 12" **MC-PTS** 18" x 12" **MC-PT** 18" x 12" **MC-PT-JB**

3

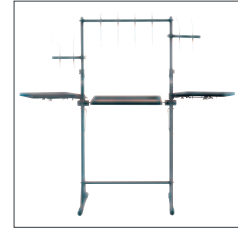

HEIGHT ADJUSTABILITY AT ALL POINTS



Black powder coated **TMPWS**

4



ALL MEINL TRIPOD STANDS ARE EQUIPPED WITH MEMORY- AND QUICK LOCKS



16" x 22" **TMPTS**

5



INVENTOR: TAKU HIRANO, USA



ERGONOMIC SHAPE FOR MORE EFFICIENCY



20" x 34" **TMPETS**

3 PERCUSSION WORKSTATION

Made with great attention to detail, the MEINL Percussion Workstation has been designed to be customized according to the player's demand.

MATERIAL Black powder coated steel

FEATURES Fully height adjustable
Angle adjustable top bar
Fabric anti-slip surface
Heavy duty construction
Infinitely expandable
Fabric anti-slip surfaces
Colour doesn't interfere with stage lighting

INCLUDES 1 pc 22" x 24" padded fiberglass percussion table
2 pcs 18" x 12" padded fiberglass percussion tables (attachable)

1 pc 30" vertical bar
2 pcs 15" vertical bars (attachable)
4 pcs straight rods with hook
3 pcs angled rods with hook
1 pc Z-shaped rod with hook

4 PERCUSSION TABLE STAND

Our Percussion Table Stand offers enough room for all common hand percussion instruments. It is fully height adjustable and has a fabric anti-slip surface.

SIZE 16" x 22"

MATERIALS Table: Premium fiberglass
Stand: Chrome plated steel

FEATURES Fabric anti-slip surface
Fully height adjustable
Double braced tripod legs

INCLUDES Allen wrench
Memory lock

5 ERGO TABLE

The curved shape helps you to fit it into your set-up with no space wasted, while keeping everything within easy reach. The inner raised edge is padded, so that instruments may be picked up and set down with an absolute minimum of contact noise.

SIZE 20" x 34"

MATERIALS Table: Premium fiberglass
Stand: Chrome plated steel

FEATURES Fabric anti-slip surface
Padded edge
Fully height adjustable
Ergonomic shape for more efficiency
Double braced tripod legs

INCLUDES Allen wrench
Memory lock

1

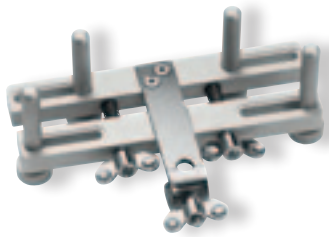

Frame Drum Holder
MC-FDH

FULLY ADJUSTABLE FOR ANY FRAME DRUM SIZE

2



Tambourine Holder
MC-TH

PADDED SURFACE AGAINST RATTLING

3



Wood Block Holder
MWBH1

4

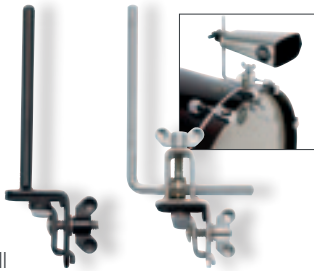

Cowbell Bass Drum Holders
MC-STBD **MC-BD**

5

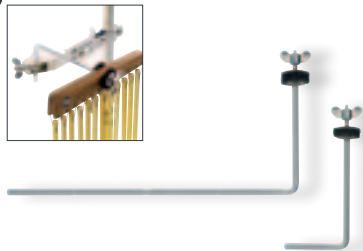

Chimes Holders
MC-CHL **MC-CH**

6



Triangle Holder
MC-TRI

7

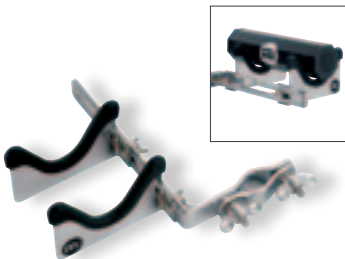

Shaker Holder
MC-SH

8



Güiro Holder
MC-GU

9



Cabasa Holder
MC-CA

10



Ibo Holder
TMIH

ENABLES TO PLAY THE IBO WITH BOTH HANDS ON A TABLE

11



Drumstick Holder
MEINL
MC-DSH

11



Drumstick Holder
Jawbreaker
MC-DSH-JB

HOLDERS

MEINL offers a wide range of holders and other hardware for several instruments or needs. Smart designed and practical in use.

MATERIAL Chrome plated steel
(if not differently indicated)

1 FRAME DRUM HOLDER

MATERIALS Anodized aluminum
Chrome plated steel
FEATURE Fully adjustable

2 TAMBOURINE HOLDER

FEATURES Rubber pads against scratching
Padded surface against rattling

3 WOOD BLOCK HOLDER

4 COWBELL BASS DRUM HOLDERS

MATERIALS **MC-BD:** Chrome plated steel
MC-STBD: Black powder coated steel
FEATURES Fully adjustable
Rubber pads against scratching
INCLUDES L-shaped rod

5 CHIMES HOLDERS

SIZES Regular
Large
FEATURES Knurled surface
Foam washer

6 TRIANGLE HOLDER

FEATURES Knurled surface
Nylon cord

7 SHAKER HOLDER

FEATURES Rubber pads against scratching
Length adjustable
Strong mounting clamp

8 GÜIRO HOLDER

FEATURE Rubber pads against scratching

9 CABASA HOLDER

FEATURES Strong mounting clamp
Padded surface

10 IBO HOLDER

MATERIAL Black powder coated steel
FEATURES Allen wrench
Foam padded base

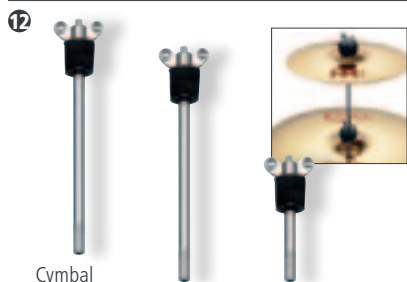

Cymbal Stackers
MC-CYS MC-CYS8 MC-CYS8-S

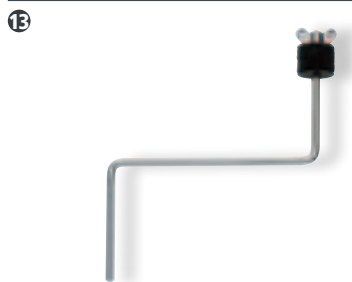

Cymbal Holder
MC-CY



Cymbal Attachment
MCA

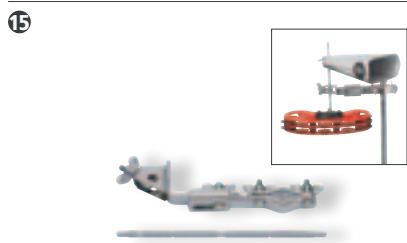

Multi Clamp, one mount
MC-1

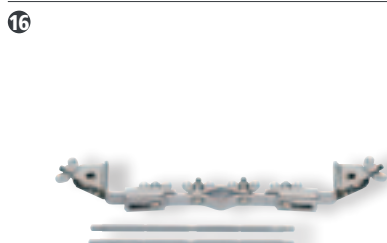

Multi Clamp, two mounts
MC-2

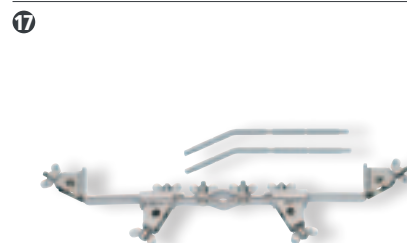

Multi Clamp, four mounts
MC-4

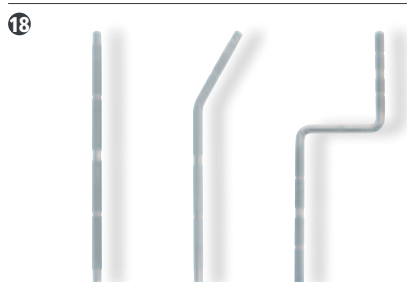

Straight rod **MC-R1**
Angled rod **MC-R2**
Z-shaped rod **MC-R3**

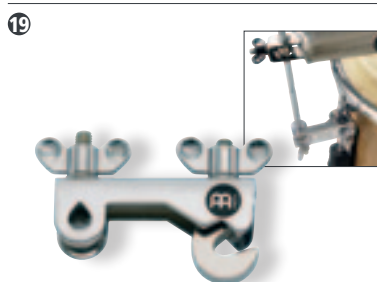

Clamp
CLAMP



Pedal Mount
PM-1

FITS ON ALL COMMON
BASS DRUM PEDALS AND
FIRMLY HOLDS COWBELLS,
BLOCKS, OR TAMBOURINES

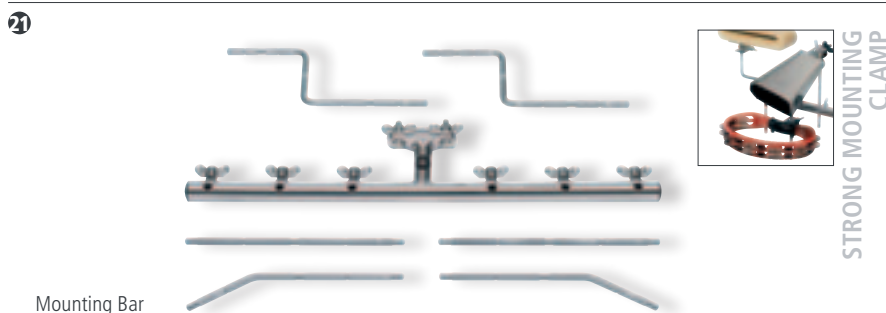

Mounting Bar
PMC-6

STRONG MOUNTING
CLAMP

11 DRUMSTICK HOLDERS

MATERIAL Black textile pouch
FEATURE Strong mounting clamp
FINISHES **MC-DSH**: MEINL
MC-DSH-JB: Jawbreaker motif

12 CYMBAL STACKERS

SIZES **MC-CYS**: ø 6 mm, long
MC-CYS8: ø 8 mm, long
MC-CYS8-S: ø 8 mm, short
FEATURE Felt washers

13 CYMBAL HOLDER

FEATURES Knurled surface
Felt washers

14 CYMBAL ATTACHMENT

FEATURES Multi-clamp
Cymbal boom arm

MULTI CLAMPS 15 16 17

FEATURES Length adjustable
Strong mounting clamp

15 MULTI CLAMP, ONE MOUNT

INCLUDES Straight rod

16 MULTI CLAMP, TWO MOUNTS

INCLUDES 2 straight rods

17 MULTI CLAMP, FOUR MOUNTS

INCLUDES 2 straight rods
2 angled rods

18 RODS

SHAPES Angled rod, Straight rod, Z-shaped rod
FEATURE Knurled surface

19 CLAMP

FEATURE Compact and solid design

20 PEDAL MOUNT

MATERIAL Black powder coated steel
FEATURES Height adjustable legs
Metal spikes attached to the bottom
INCLUDES 2 differently sized L-rods

21 MOUNTING BAR, SIX PCS.

INCLUDES 2 straight rods
2 angled rods
2 Z-shaped rods

1



ADDITIONAL UPRIGHT ZIPPER

MCOB-11

MCOB-1134

MCOB-1212

2

NEW!



MSTCOB

FITS FOR ALL SIZES

3



MSTBB1

4



MBB

5



MTB

6



MCHB

2 INTERNAL POCKETS WITH INNER HOOK AND LOOP FASTENER STRAPS

PROFESSIONAL MEINL BAGS

All Professional MEINL Bags are made from heavy duty nylon with reinforced stitching. They protect your instruments and assure hassle free transportation.

1 PROFESSIONAL CONGA BAGS

An extra top zipper simplifies packing and unpacking of your drum. Additional features are padded backpack straps and an external pocket for accessories.

MATERIAL Heavy duty nylon

SIZES 11", 11 3/4", 12 1/2"

FEATURES Additional upright zipper
External pocket
Padded backpack straps
Carrying grip

2 CONGA GIG BAG

The MEINL Conga Gig Bag fits for all sizes. Featuring a carrying grip and a shoulder strap for easy transportation.

MATERIAL Heavy duty nylon

FEATURES Carrying grip
Shoulder strap
Outer pocket

3 BONGO GIG BAG

MATERIAL Heavy duty nylon

SIZE Bongos up to 7 1/2" Macho & 8 1/2" Hembra

FEATURE Carrying grip

4 PROFESSIONAL BONGO BAG

MATERIAL Heavy duty nylon

FEATURES Additional room for accessories
Padded shoulder strap
Carrying grip, Padded separator

5 PROFESSIONAL TIMBALES BAG

MATERIAL Heavy duty nylon

SIZES 14" & 15"

FEATURES External pocket for stand and cowbell
Padded shoulder strap
Carrying grip
Padded separator

6 PROFESSIONAL CHIMES BAG

MATERIAL Heavy duty nylon

FEATURES Stores up to 2 chimes
Carrying grip
Inner hook and loop fastener straps
2 internal pockets



10" **DCAP-M** 12" **DCAP-L** 13" **DCAP-XL**



MDJB-L **MDJB-M** **MDJB-S**



MDLXDJB-M **MDLXDJB-L**

SYNTHETIC FUR FOR EXTRA PROTECTION



MSTDJB

NEW!

FITS FOR ALL SIZES

7 PROFESSIONAL DJEMBE CAPS
 These caps protect your drum with a heavy duty reinforced top and an extra-long skirt with an elastic waist band.
MATERIAL Heavy duty nylon
SIZES **M:** 10", **L:** 12", **XL:** 13"
COLOUR Black

8 PROFESSIONAL DJEMBE BAGS
MATERIAL Heavy duty nylon
SIZES Small (up to 10")
 Medium (up to 12")
 Large (up to 13 1/2")
FEATURES External pocket
 Carrying grip
MDJB-M, MDJB-L:
 Padded backpack straps

9 DELUXE DJEMBE BAGS
MATERIAL Heavy duty nylon
SIZES Medium (up to 12")
 Large (up to 13 1/2")
FEATURES Synthetic fur
 External pocket
 Padded backpack straps
 Carrying grip

10 DJEMBE GIG BAG
 The MEINL Djembe Gig Bag fits for all sizes. Featuring a carrying grip and a shoulder strap for easy transportation.
MATERIAL Heavy duty nylon
FEATURES Carrying grip
 Shoulder strap
 Outer pocket





10" x 10"
MREB-10

12" x 12"
MREB-12



6"
MQW-6

8"
MQW-7

10"
MQW-10



12" x 18"
MREBB-12



12" x 4 1/2"
MCA-12

12" x 6"
MCA-12T

14" x 4"
MCA-14

EXTRA POCKET FOR SPARE HEADS

1 PROFESSIONAL REPINIQUE BAGS

MATERIAL Heavy duty nylon

SIZES 10" x 10"
12" x 12"

FEATURES Double-slide zipper
Shoulder strap
Carrying grip
External pocket

2 PROFESSIONAL CUICA BAGS

MATERIAL Heavy duty nylon

SIZES 6", 8", 10"

FEATURES Padded shoulder strap
Carrying grip
External pocket

3 PROFESSIONAL REBOLO BAG

MATERIAL Heavy duty nylon

SIZE 12" x 18"

FEATURES Double-slide zipper
Padded shoulder strap
Carrying grip
External pocket

4 PROFESSIONAL CAIXA BAGS

MATERIAL Heavy duty nylon

SIZES 12" x 4 1/2"
12" x 6"
14" x 4"

FEATURES Double-slide zipper
Extra pocket for spare heads
Shoulder strap
Carrying grip
External pocket

5



14" x 28"
MTIMB-1428

14" x 35"
MTIMB-1435

6



14" x 28"
MTANB-14

7



16" x 20"
MSUB-16

18" x 22"
MSUB-18

20" x 24"
MSUB-20

22" x 24"
MSUB-22

5 PROFESSIONAL TIMBA BAGS

MATERIAL Heavy duty nylon

SIZES 14" x 28"

14" x 35"

FEATURES Double-slide zipper
Padded backpack straps
Carrying grip
External pocket

6 PROFESSIONAL TANTAM BAG

MATERIAL Heavy duty nylon

SIZE 14" x 28"

FEATURES Double-slide zipper
Padded backpack straps
Carrying grip
External pocket

7 PROFESSIONAL SURDO BAGS

MATERIAL Heavy duty nylon

SIZES 16" x 20"

18" x 22"

20" x 24"

22" x 24"

FEATURES Double-slide zipper
Padded backpack straps
Carrying grip
External pocket



1 PROTECTION COVER FOR HEADLINER® CAJONS

This protection cover offers dependable protection at an affordable price, assuring your cajon will look as good as it sounds for a long time to come.

MATERIAL Heavy duty nylon
COLOUR Black
FEATURE Fits for all HCAJ1 models

2 CAJON GIG BAG

MATERIAL Heavy duty nylon
MEASURES 20 1/2" W x 12" H x 12" D
FEATURE Carrying grip

3 PROFESSIONAL CAJON BAG

MATERIAL Heavy duty nylon
MEASURES 20 1/2" W x 12" H x 12" D

FEATURES Padded shoulder strap
 External pocket
 Carrying grip

4 DELUXE CAJON BAG

The MEINL Deluxe Cajon Bag features an additional layer of synthetic fur, which removes surface moisture and provides extra protection. Additional features are a padded shoulder strap and an external pocket for accessories.

MATERIAL Heavy duty nylon
MEASURES 20 1/2" W x 12" H x 12" D
FEATURES Synthetic fur
 Padded shoulder strap
 External pocket
 Carrying grip

5 DELUXE BASS PEDAL CAJON BAG

The MEINL Deluxe Cajon Bag is perfectly suited for the bigger sized Bass Pedal Cajon.

MATERIAL Heavy duty nylon
MEASURES 21 1/2" W x 17" H x 14 1/2" D
FEATURES Synthetic fur
 Padded shoulder strap
 External pocket
 Carrying grip

6 PROFESSIONAL TREJON/MARIMBULA BAG

MATERIAL Heavy duty nylon
MEASURES 21" W x 20" H x 18" D
FEATURES Extra padding for security
 External pockets for small percussion
 Padded backpack straps

SYNTHETIC FUR FOR ADDITIONAL PROTECTION



16" x 2 1/2" **MFDB-16** 18" x 2 1/2" **MFDB-18** 20" x 2 1/2" **MFDB-20** 22" x 2 1/2" **MFDB-22**



8 1/2" x 2 1/2" **MFDB-7KA**



6" **MTAB-06** PERFECT FIT



12" x 4" **MFDB-12BE** 14" x 4" **MFDB-14BE** 14" x 6" **MFDB-14IBO** 18" x 4" **MFDB-18BO** 22" x 4" **MFDB-22-D**



10" **MPAB-10** 12" **MPAB-12** ALSO FITS FOR OUR 10" TAMBOURINES



10" **MSTTB**

7 TRAVEL CAJON GIG BAG

MATERIAL Heavy duty nylon
SIZE 12"
FEATURES Double-slide zipper
 Carrying grip

8 PROFESSIONAL FRAME DRUM BAGS

MATERIAL Heavy duty nylon
SIZES 16", 18", 20", 22"
 2 1/2" deep
FEATURES Double-slide zipper
 Shoulder strap, Carrying grip

9 PROFESSIONAL KANJIRA BAG

MATERIAL Heavy duty nylon
SIZE 8 1/2" x 2 1/2"
FEATURES Double-slide zipper
 Shoulder strap, External pocket

10 PROFESSIONAL TAMBORIM BAG

MATERIAL Heavy duty nylon
SIZE 6"
FEATURES Double-slide zipper
 Shoulder strap
 External pocket

11 PROFESSIONAL DEEP SHELL FRAME DRUM BAGS

MATERIAL Heavy duty nylon
SIZES **MFDB-12BE:** 12" x 4"
MFDB-14BE: 14" x 4"
MFDB-14IBO: 14" x 6"
MFDB-18BO: 18" x 4"
MFDB-22-D: 22" x 4"
FEATURES Double-slide zipper
 Shoulder strap
 Carrying grip

12 PROFESSIONAL PANDEIRO BAGS

MATERIAL Heavy duty nylon
SIZES 10", 12"
FEATURES Double-slide zipper
 Shoulder strap
 External pocket

13 TAMBOURINE GIG BAG

MATERIAL Heavy duty nylon
SIZE 10"
FEATURES Sturdy zipper
 Carrying grip



MDAB



MDOB



MDDGB



MDDGB-PRO



MIB-S

MIB-M

MIB-L



MDLXSB



EXTERNAL
POCKETS



Black
MSB-1

Original Camo
MSB-1-C1

Jawbreaker
MSB-1-JB

SPACIOUS STICK COMPARTMENT FOR QUICK ACCESS

1 PROFESSIONAL DARBUKA BAG

MATERIAL Heavy duty nylon
FEATURES Double-slide zipper
Additional upright zipper
Padded shoulder strap
Carrying grip
External pocket

2 PROFESSIONAL DOUMBЕК BAG

MATERIAL Heavy duty nylon
FEATURES Double-slide zipper
Additional upright zipper
Padded shoulder strap
Carrying grip
External pocket

3 STRAIGHT DIDGERIDOO BAG

MATERIAL Heavy duty nylon

SIZE 53"
FEATURES Padded shoulder strap
External pocket

4 PRO DIDGERIDOO BAG

MATERIAL Heavy duty nylon
SIZE 58"
FEATURES Padded shoulder strap
External pocket

5 PROFESSIONAL IBO BAGS

MATERIAL Heavy duty nylon
SIZES Small (9 3/4" W x 13 1/3" H x 9 3/4" D)
Medium (11" W x 14 1/2" H x 11" D)
Large (11 3/4" W x 15" H x 11 3/4" D)
INCLUDES Padded shoulder strap
Carrying grip
External pocket

6 PROFESSIONAL STICK BAGS

MATERIALS **MSB-1, MSB-1-C1:** Heavy duty nylon
MSB-1-JB: Leatherette
FEATURES External pockets
Shoulder straps
Extension straps
COLOURS Black
Jawbreaker
Original Camouflage

7 DELUXE STICK BAG

MATERIAL Padded synthetic leather
FEATURES External pockets
Shoulder straps
Elastic cord attachments
COLOUR Black



Black
MSTC22



Black
MCB22

Original Camo
MCB22-C1

Jawbreaker
MCB22-JB



Black
MCB22/MSB

CYMBALS AND STICKS ARE ALWAYS READY AT HAND



Original Camo
MCB22/MSB-C1

FRONT



Black
MCB22-BP

BACK

8 CYMBAL GIG BAG

The MEINL Cymbal Gig Bag holds cymbals up to 22" in diameter. It is produced in a high quality standard at an affordable price.

MATERIAL Heavy duty nylon

SIZE 22"

FEATURES Shoulder strap
Carrying grip

COLOUR Black

9 PROFESSIONAL CYMBAL BAGS

The Meinl 22" Professional Cymbal Bags are available in 3 different finishes. They have a small external pocket for other Drum Gear and an external hihat / splash compartment designed to hold cymbals up to 15" in diameter.

MATERIALS **MCB22, MCB22-C1:** Heavy duty nylon
MCB22-JB: Leatherette

SIZE 22"

FEATURES Padded dividers
Padded shoulder strap

COLOURS Black
Jawbreaker
Original Camouflage

10 COMBO BAGS

An exceptional combination of a Meinl 22" Cymbal Bag and a Meinl Stick Bag. They come together from a zipper on the backside. Cymbals and sticks are always ready at hand.

MATERIAL Heavy duty nylon

SIZE 22"

FEATURES External compartment
Padded dividing pads
Padded shoulder strap
Carrying grip

COLOURS Black
Original Camouflage

11 PROFESSIONAL CYMBAL BACKPACK

The 22" Cymbal Bag has two backpack straps on the backside for easy transportation. External hihat/splash compartment which holds cymbals up to 15" in diameter, includes a glow-in-the-dark Meinl logo for spotting your bag in darkly lit venues.

MATERIAL Heavy duty nylon

SIZE 22"

FEATURES External hihat / splash compartment
Glow-in-the-dark Meinl logo
Two backpack straps on the backside

COLOUR Black



Support your favourite percussion brand with the official MEINL swag. A selection of exclusive items made from the highest quality materials.

1 T-SHIRT

SIZES S, M, L, XL, XXL
COLOUR Black
FRONT MEINL logo, small
BACK MEINL logo, big

2 T-SHIRT (MADE BY PUMA)

SIZES S, M, L, XL, XXL
COLOUR Black
FRONT Embroidered small MEINL logo and PUMA logo

3 JAWBREAKER T-SHIRT

SIZES S, M, L, XL
COLOUR Black
FRONT Jawbreaker

4 JAWBREAKER LONG SLEEVE

SIZES S, M, L, XL
COLOUR Black
FRONT Jawbreaker

5 POLO SHIRT

SIZES S, M, L, XL, XXL
COLOUR Black
FRONT MEINL logo, small

6 POLO SHIRT (MADE BY PUMA)

SIZES S, M, L, XL, XXL
COLOUR Black
FRONT Embroidered small MEINL logo and PUMA logo

7 HOOD SHIRT W/ ZIPPER

SIZES S, M, L, XL, XXL
COLOUR Black
FRONT MEINL logo, small
BACK MEINL logo, big

8 HOOD SHIRT (MADE BY PUMA)

SIZES S, M, L, XL, XXL
COLOUR Black
FRONT Embroidered small MEINL logo and PUMA logo

13



Tour Trolley
T-PBT-BK

14



Army cap, black
M20 Army cap, khaki
M21

15



Mouse Pad
M59

16



Gig Towel, medium
MEI-HANDTUCH2

Gig Towel, large
MEI-HANDTUCH3

17



Bar stool, 24"
MBS24

Bar stool, 30"
MBS30

18



Jawbreaker Sling Bag
M-BAG-BK-JB

Jawbreaker Sling Bag
M-BAG-JB

19



Lanyard
M22

9 JAWBREAKER HOOD SHIRT W/ ZIPPER

SIZES S, M, L, XL, XXL
COLOUR Black
FRONT MEINL logo, small
BACK Jawbreaker

10 JAWBREAKER HOOD SHIRT

SIZES S, M, L, XL, XXL
COLOUR Black
FRONT MEINL logo, small
BACK Jawbreaker

11 TRAINING JACKET

SIZES S, M, L, XL, XXL
COLOUR Black
FRONT MEINL logo, small
BACK MEINL logo, big

12 TRAINING JACKET (MADE BY PUMA)

SIZES S, M, L, XL, XXL
COLOUR Black
FRONT Embroidered small MEINL logo and PUMA logo

13 TOUR TROLLEY

14 ARMY CAPS

COLOURS Black
Khaki

15 MOUSE PAD

16 GIG TOWELS

SIZES Medium
Large

17 BAR STOOLS

SIZES 24", 30"

18 JAWBREAKER SLING BAGS

COLOURS **M-BAG-BK-JB**: Black
M-BAG-JB: Red

19 LANYARD



JOIN OUR SOCIAL NETWORK

Unlike most companies MEINL is not just about the business. We are focused on you... the players... those who make music with our instruments. With all of the new social networks this has become much easier. We invite you to send us ideas, questions, or comments. You can find us on Facebook, Google+, Youtube and Twitter.

P.S. Be sure to check out meinlpercussion.com for the latest news.

meinlpercussion.com

MEINL PERCUSSION
THE ULTIMATE SELEC

OCTOBER 23 via News

MEINL TIMBALES ARE ON FIRE WITH

Stuckeln Abdala is now par

SHOW

PRODUCTS ARTISTS COMPANY DEALERS



facebook.com/meinlpercussionfanpage



twitter.com/meinlpercussion



youtube.com/meinlpercussion



gplus.to/meinlpercussion

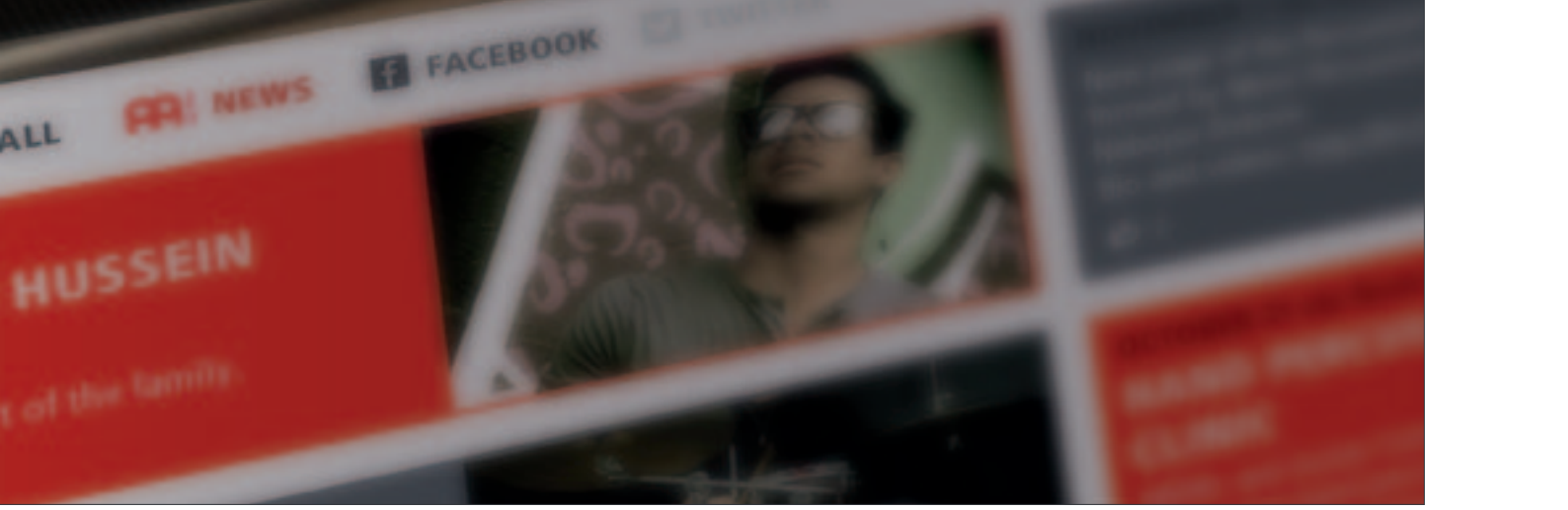

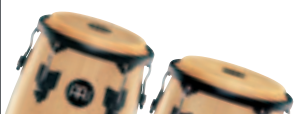

MEINL REPLACEMENT PARTS

Model No.	Size	Height	Material	Features	REPLACEMENT PARTS					Page		
					Head	Rim	Lug	Bracket				
CONGAS												
												
HEADLINER® SERIES WOOD CONGA SETS												
HC512 (incl. Basket Stand)	11" + 12"	28"	X		X			HHEAD11/HHEAD12C	HRIM11/HRIM12C	HCLUG	HCBRACKET-02	019-021
HC555 (incl. Basket Stand)	10" + 11"	28"	X		X			HHEAD10/HHEAD11	HRIM10/HRIM11	HCLUG	HCBRACKET-02	019-021
HEADLINER® DESIGNER SERIES CONGAS												
HC10 (incl. Basket Stand)	10"	28"	X		X			HHEAD10	HRIM10	HCLUG	HCBRACKET-02	022
HC11 (incl. Basket Stand)	11"	28"	X		X			HHEAD11	HRIM11	HCLUG	HCBRACKET-02	022
HC12 (incl. Basket Stand)	12"	28"	X		X			HHEAD12C	HRIM12C	HCLUG	HCBRACKET-02	022
HEADLINER® TRADITIONAL DESIGNER SERIES CONGAS												
HTC10 (incl. Basket Stand)	10"	28"	X			X		HHEAD10T	HRIM10T	HCLUG	HCBRACKET-02	023
HTC11 (incl. Basket Stand)	11"	28"	X			X		HHEAD11T	HRIM11T	HCLUG	HCBRACKET-02	023
HTC12 (incl. Basket Stand)	12"	28"	X			X		HHEAD12T	HRIM12T	HCLUG	HCBRACKET-02	023
HEADLINER® SERIES CONGA SETS												
HC812 (incl. Double Stand)	11" + 12"	28"	X		X			HHEAD11/HHEAD12C	HRIM11/HRIM12C	HCLUG	HCBRACKET-02	024/025
HC888 (incl. Double Stand)	10" + 11"	28"	X		X			HHEAD10/HHEAD11	HRIM10/HRIM11	HCLUG	HCBRACKET-02	024/025
MARATHON® CLASSIC SERIES CONGA SET												
MCC-SET-ATB-M (incl. Double Stand)	11" + 11 3/4"	30"	X		X	X	X	TS-B-38/TS-B-39	SSR-25/SSR-26	LUG-03	BRACKET-15	025
HEADLINER® FIBERGLASS SERIES CONGAS												
HFC10 (incl. Basket Stand)	10"	28"		X		X		HHEAD10	HRIM10	HCLUG	HCBRACKET-02	026
HFC11 (incl. Basket Stand)	11"	28"		X		X		HHEAD11	HRIM11	HCLUG	HCBRACKET-02	026
HFC12 (incl. Basket Stand)	12"	28"		X		X		HHEAD12C	HRIM12C	HCLUG	HCBRACKET-02	026
ARTIST SERIES, LUIS CONTE												
LC11	11"	30"	X		X	X	X	TS-B-52	TTR-28	LUG-03	BRACKET-20	026
LC1134	11 3/4"	30"	X		X	X	X	TS-B-53	TTR-29	LUG-03	BRACKET-20	026
LC1212	11 1/2"	30"	X		X	X	X	TS-B-54	TTR-30	LUG-03	BRACKET-20	026
MARATHON® CLASSIC SERIES / DESIGNER SERIES												
MCC11 (incl. Steely-II Stand)	11"	30"	X		X	X	X	TS-B-38	SSR-25	LUG-03	BRACKET-15	027-029
MCC1134 (incl. Steely-II Stand)	11 3/4"	30"	X		X	X	X	TS-B-39	SSR-26	LUG-03	BRACKET-15	027-029
MCC1212 (incl. Steely-II Stand)	12 1/2"	30"	X		X	X	X	TS-B-40	SSR-27	LUG-03	BRACKET-15	027-029
PROFESSIONAL SERIES												
MP11	11"	30"	X		X	X	X	TS-B-34	SSR-22	LUG-01	BRACKET-14	030/031
MP1134	11 3/4"	30"	X		X	X	X	TS-B-35	SSR-23	LUG-01	BRACKET-14	030/031
MP1212	12 1/2"	30"	X		X	X	X	TS-B-36	SSR-24	LUG-01	BRACKET-14	030/031
FIBERCRAFT SERIES / DESIGNER SERIES												
FC11	11"	30"		X	X	X	X	TS-B-34	SSR-22	LUG-01	BRACKET-14	032/033
FC1134	11 3/4"	30"		X	X	X	X	TS-B-35	SSR-23	LUG-01	BRACKET-14	032/033
FC1212	12 1/2"	30"		X	X	X	X	TS-B-36	SSR-24	LUG-01	BRACKET-14	032/033
FLOATUNE SERIES												
FL10	10"	30"	X		X	X	X	TS-B-01	SSR-06	LUG-01		034
FL11	11"	30"	X		X	X	X	TS-B-03	SSR-07	LUG-01		034
FL12	12"	30"	X		X	X	X	TS-B-15	SSR-12	LUG-01		034
FL13	13"	30"	X		X	X	X	TS-B-21	SSR-15	LUG-01		034
ARTIST SERIES, MONGO SANTAMARIA												
MSA11	11"	30"		X	X	X	X	TS-B-07	SSR-08	LUG-02	BRACKET-16	034
MSA1134	11 3/4"	30"		X	X	X	X	TS-B-11	SSR-10	LUG-02	BRACKET-16	034
MSA1212	12 1/2"	30"		X	X	X	X	TS-B-17	SSR-13	LUG-02	BRACKET-16	034
WOODCRAFT SERIES												
WC11	11"	30"		X	X	X	X	TS-B-44	TTR-23	LUG-01	BRACKET-14	035
WC1134	11 3/4"	30"		X	X	X	X	TS-B-45	TTR-24	LUG-01	BRACKET-14	035
WC1212	12 1/2"	30"		X	X	X	X	TS-B-46	TTR-25	LUG-01	BRACKET-14	035

REPLACEMENT PARTS FOR STANDS				
10" Basket Stand for HC555 / Designer Series / Fiberglass Series			HSTAND10	019-026
11" Basket Stand for HC555 / HC512 / Designer Series / Fiberglass Series			HSTAND11	019-026
12" Basket Stand for HC512 / Designer Series / Fiberglass Series			HSTAND12	019-026
Rubber Feet (set of 3 pcs.) for Steely-II Stand			STAND-35	166
Rubber Tops (set of 3 pcs.) for Steely-II Stand			STAND-21	166
Screw Set complete for Steely-II Stand, black			STAND-22	166
Screw Set complete for Steely-II Stand, chrome			STAND-23	166
Screw Set complete for Steely-II Stand, gold tone			STAND-24	166
Socket Screw (set of 2 pcs.) black			STAND-26	166
Socket Screw (set of 2 pcs.) chrome			STAND-27	166
Socket Screw (set of 2 pcs.) gold tone			STAND-28	166
Brackets for HDSTAND and TMDS			HDBRACKET-04	166

OTHER PARTS				
Lug Oil			SPARE-09	
Conga Saver for 8 mm Lugs (set of 6 pcs.)			CONGA-SAVER8	
Conga Saver for 10 mm Lugs (set of 6 pcs.)			CONGA-SAVER10	
Tuning Key, 13 mm + 14 mm, L shaped, gold tone			KEY-01	
Tuning Key, 13 mm + 14 mm, L shaped, chrome			KEY-02	

										REPLACEMENT PARTS						
Model No.	Size	Material					Features				Head	Rim	Lug	Bracket	Page	
		Acrylic	ABS Plastic	American White Ash	Rubber Wood	Plywood	Premium Fiberglass	True Skin Cow Heads	True Skin Buffalo Heads	SSR-Rim	TTR-Rim	Free Ride System				
BONGOS																
HEADLINER® SERIES ABS BONGO / ACRYLIC BONGO																
HB50	6 1/2"	X	X										HHEAD6,5	RIM-NI3-65-BK	LUG-NINO3	038/039
HB50	7 1/2"	X	X										HHEAD7,5	RIM-NI3-75-BK	LUG-NINO3	038/039
HEADLINER® SERIES WOOD BONGOS / DESIGNER / FIBERGLASS SERIES / TRADITIONAL																
HB100	6 3/4"				X								HHEAD634W	HRIM634W	HBLUG	038/039
HB100	8"				X								HHEAD8W	HRIM8W	HBLUG	038/039
HFB100	6 3/4"						X						HHEAD634W	HRIM634W	HBLUG	039
HFB100	8"					X							HHEAD8W	HRIM8W	HBLUG	039
HTB100	6 3/4"				X								HHEAD634T	HBRIM634T	HBLUG	039
HTB100	8"				X								HHEAD8T	HBRIM8T	HBLUG	039
FREE RIDE SERIES FWB190 WOOD BONGOS / DESIGNER SERIES																
FWB190	6 3/4"				X				X	X			HEAD-38	SSR-18	LUG-22	040
FWB190	8"				X				X	X			HEAD-39	SSR-19	LUG-22	040
FREE RIDE SERIES MINI WOOD BONGOS																
FWB100	3 1/2"				X		X	X	X	X			TS-B-31	SSR-16	LUG-19	041
FWB100	4 1/4"				X		X	X	X	X			TS-B-32	SSR-17	LUG-19	041
FREE RIDE SERIES FWB200 WOOD BONGOS																
FWB200	6 3/4"				X				X	X			HEAD-38	SSR-20	LUG-22	041
FWB200	8"				X				X	X			HEAD-39	SSR-21	LUG-22	041
LUIS CONTE ARTIST SERIES WOOD BONGO																
LC300	6 3/4"				X		X		X	X			TS-C-13	TTR-31	LUG-22	041
LC300	8"				X		X		X	X			TS-C-14	TTR-32	LUG-22	041
FREE RIDE SERIES FFB200 FIBERGLASS BONGOS																
FFB200	6 3/4"					X		X	X	X			TS-B-50	SSR-34	LUG-23	042
FFB200	8"					X		X	X	X			TS-B-51	SSR-35	LUG-23	042
FREE RIDE SERIES FFB400 FIBERGLASS BONGOS / DESIGNER SERIES																
FFB400	7"					X	X	X	X	X			TS-C-02	SSR-02	LUG-07	042
FFB400	8 1/2"					X	X	X	X	X			TS-C-03	SSR-04	LUG-07	042
FREE RIDE SERIES FWB400 WOOD BONGO																
FWB400	7"				X		X	X	X	X			TS-C-02	SSR-02	LUG-07	043
FWB400	8 1/2"				X		X	X	X	X			TS-C-03	SSR-04	LUG-07	043
FREE RIDE SERIES COLLECTION WOOD BONGO																
CS400	7"		X			X	X	X	X	X			TS-C-02	SSR-02	LUG-07	043
CS400	8 1/2"		X			X	X	X	X	X			TS-C-03	SSR-04	LUG-07	043
FREE RIDE SERIES WOODCRAFT BONGO																
WB500	7"		X			X		X	X	X			TS-C-11	TTR-26	LUG-07	043
WB500	9"		X			X		X	X	X			TS-C-12	TTR-27	LUG-07	043
MEINL RAPC BONGO																
MB400	6 3/4"				X			X	X	X			HEAD-38	SSR-20	LUG-22	045
MB400	8"				X			X	X	X			HEAD-39	SSR-21	LUG-22	045
REPLACEMENT PARTS FOR STANDS																
Memory Clamp, chrome, for middle stand tube for TMB + TMB-S											STAND-07		167			
Memory Clamp, chrome, for lower stand tube for TMB + TMB-S											STAND-09		167			
Memory Clamp, chrome, for upper stand tube for TMB											STAND-11		167			
Fast Lock Set, chrome for TMB + TMB-S											STAND-14		167			
Rubber Feet (set of 3 pcs.) for all Bongo Stands											STAND-16		167			
L-Shaped Clamp for top part for TMB + TMB-S											STAND-18		167			
Upper Stand Section, complete for TMB											STAND-34		167			
OTHER PARTS																
Lug Oil											SPARE-09					
Tuning Key, 13 mm + 14 mm, L-shaped, chrome											KEY-02					

										REPLACEMENT PARTS			
Model No.											Name	Model No.	Page
	FOOT CABASA / TRIANGLES												
FOOT CABASA													
FCAS-L											Coil springs	SPARE-20	092
FCAS-L											Regular spring	SPARE-26	092
FCAS-L											Cabasa complete	SPARE-35	092
FCAS-L											Stopper	SPARE-43	092
TRIANGLES													
TRI10B											Beater	SPARE-31	145
TRI15B											Beater	SPARE-31	145
TRI20B											Beater	SPARE-31	145
JCTRI20											Beater	SPARE-31	145



MEINL REPLACEMENT PARTS

Model No.	Size	Height	Material	Features	REPLACEMENT PARTS					Page						
					Head	Rim	Lug	Bracket								
DJEMBES																
HEADLINER® SERIES ROPE TUNED WOOD DJEMBES NILE SERIES																
HDJ4-S	8"	15 3/4"	X					X			HEAD-61					048
HDJ4-M	10"	20"	X					X			HEAD-53					048
HDJ4-L	12"	24"	X					X			HEAD-54					048
HDJ4-XL	13"	25"	X					X			HEAD-55					048
HEADLINER® SERIES ROPE TUNED WOOD DJEMBES BLACK RIVER SERIES																
HDJ3-S	8"	15 3/4"	X					X			HEAD-61					048
HDJ3-M	10"	20"	X					X			HEAD-53					048
HDJ3-L	12"	24"	X					X			HEAD-54					048
HDJ3-XL	13"	25"	X					X			HEAD-55					048
HEADLINER® SERIES ROPE TUNED WOOD DJEMBES CONGO SERIES																
HDJ1-S	8"	15 3/4"	X					X			HEAD-61					049
HDJ1-M	10"	20"	X					X			HEAD-53					049
HDJ1-L	12"	24"	X					X			HEAD-54					049
HDJ1-XL	13"	25"	X					X			HEAD-55					049
HEADLINER® SERIES ROPE TUNED WOOD DJEMBES TRIBAL SERIES																
HDJ2-S	8"	15 3/4"	X					X			HEAD-61					049
HDJ2-M	10"	20"	X					X			HEAD-53					049
HDJ2-L	12"	24"	X					X			HEAD-54					049
HDJ2-XL	13"	25"	X					X			HEAD-55					049
ORIGINAL AFRICAN STYLE ROPE TUNED WOOD DJEMBES																
ADJ2, 3, 4-M+BAG	10"	20"	X					X			HEAD-53					050/051
ADJ2, 3, 4-L+BAG	12"	24"	X					X			HEAD-54					050/051
ADJ2, 3, 4-XL+BAG	13"	25"	X					X			HEAD-55					050/051
AFRICAN BOUGARABOU																
ABGB-L	12"	24"	X					X			HEAD-63					052
PROFESSIONAL AFRICAN STYLE DJEMBES / DELUXE AFRICAN STYLE DJEMBES																
PROADJ1	12"	24"	X					X			HEAD-54					052
PROADJ2	12"	24"	X					X			HEAD-54					052
PROADJ3	14"	26"	X					X			HEAD-56					052
PROADJ4	12"	24"	X					X			HEAD-54					052
DJEMBEFOLAS																
DJFS1-M	10"	20"	X					X			HEAD-97					053
DJFS1-L	12"	24"	X					X			HEAD-97					053
JOURNEY SERIES ROPE TUNED FIBERGLASS DJEMBES, SYNTHETIC HEAD																
FADJ1, 2, 5, 6, 7-M	10"	18"		X	X					X	HEAD-70					054
FADJ1, 2, 5, 6, 7-L	12"	24"		X	X					X	HEAD-71					054
JOURNEY SERIES ROPE TUNED FIBERGLASS DJEMBES, GOAT HEAD																
FADJ1, 2, 5, 6, 7-M-G	10"	18"		X	X					X	HEAD-88					055
FADJ1, 2, 5, 6, 7-L-G	12"	24"		X	X					X	HEAD-89					055
MECHANICAL TUNED FIBERGLASS DJEMBE, SYNTHETIC HEAD																
FMDJ1, 2, 5, 6, 7-M-F	10"	18"		X	X					X	HEAD-90	RIM-55	BRACKET-27	BRACKET-27		056
FMDJ1, 2, 5, 6, 7-L-F	12"	24"		X	X					X	HEAD-91	RIM-56	BRACKET-27	BRACKET-27		056
MECHANICAL TUNED FIBERGLASS DJEMBE, GOAT HEAD																
FMDJ1, 2, 5, 6, 7-M-G	10"	18"		X	X					X	HEAD-92	RIM-55	BRACKET-27	BRACKET-27		057
FMDJ1, 2, 5, 6, 7-L-G	12"	24"		X	X					X	HEAD-93	RIM-56	BRACKET-27	BRACKET-27		057
PROFESSIONAL FIBERGLASS DJEMBES																
PROFADJ1-M	10"	20"		X	X					X	HEAD-70					058
PROFADJ1-L	12"	24"		X	X					X	HEAD-71					058
HEADLINER® SERIES WOOD DJEMBES																
HDJ500	12 1/2"	25 1/4"	X					X			HHEAD12,5W	HRIM12,5W	HDLUGW	HDBRACKET-02		060
FLOATUNE SERIES FIBERGLASS DJEMBES																
DJF3	12"	24 1/4"		X				X	X	X	TS-G-01	SSR-29	LUG-05			060
FLOATUNE SERIES 12" WOOD DJEMBES																
DJW3	12"	24 1/4"		X	X			X	X	X	TS-G-01	SSR-29	LUG-04			060/061
FLOATUNE SERIES 12 3/4" WOOD DJEMBES																
DJW2	12 3/4"	25 1/4"		X				X	X	X	TS-G-02	SSR-30	LUG-04			061
REPLACEMENT PARTS FOR STANDS																
Rubber Feet (set of 3 pcs.) for Steely-II Stand											STAND-35					168
Rubber Tops (set of 3 pcs.) for Steely-II Stand											STAND-21					168
Socket Screw (set of 2 pcs.) chrome											STAND-27					168
Fast Lock Set, chrome											STAND-14					168
Rubber Feet (set of 3 pcs.) for Djembe Stand											STAND-16					168
OTHER PARTS																
Lug Oil											SPARE-09					
Tuning Key, 13 mm + 14 mm, L-shaped, chrome											KEY-02					

										REPLACEMENT PARTS					
Model No.	Size	Material			Features					Head	Rim	Lug	Bracket	Page	
		Aluminum	Copper	Rubber Wood	Premium Fiberglass	Synthetic Heads	Hand selected buffalo heads	Natural rawhide	True Skin Buffalo Heads						Rim
DARBUKAS & DOUMBEKS															
ALUMINUM DARBUKAS															
HE-100	5 1/3"	X			X			X							064
HE-101	5 7/8"	X			X			X							064
HE-102	6 1/2"	X			X			X							064
HE-103	7 1/4"	X			X			X							064
HE-104	8"	X			X			X							064
HE-110	5 1/3"	X			X			X	X						064
HE-111	5 7/8"	X			X			X	X						064
HE-112	6 1/2"	X			X			X	X						064
HE-113	7 1/4"	X			X			X	X						064
HE-114	8"	X			X			X	X						064
HE-122	6 1/2"	X			X			X	X						065
HE-124	8"	X			X			X	X						065
ALUMINUM JINGLE DARBUKAS															
HE-314	8"	X			X			X	X						065
HE-315	8 1/4"	X			X			X	X						065
COPPER DARBUKAS															
HE-214	7 1/2"		X		X			X	X						065
HE-215	7 7/8"		X		X			X	X						065
HE-204	7 1/2"		X		X		X	X	X						065
HE-205	7 7/8"		X		X		X	X	X						065
FIBERGLASS DOUMBEK															
FDB3000G	8 1/2"				X	X			X						066
ALUMINUM DOUMBEKS															
HE-3000	8 1/2"	X			X			X							066
HE-3018	8 1/2"	X			X			X	X						067
HE-3020	8 1/2"	X			X			X							066
HE-3030	8 1/2"	X			X			X	X						067
HE-3400	8 1/2"	X			X			X							067
COPPER DOUMBEK															
HE-3012	8 1/2"		X		X			X	X						067
ARTISAN EDITION DOUMBEKS															
AE-ED5	8 3/4"	X			X			X							069
AE-ED7	9"	X			X			X							069
AE-ED-SB	9"	X			X			X							069

										REPLACEMENT PARTS					
Model No.	Size	Material			Features					Head	Rim	Lug	Bracket	Page	
		Aluminum	Copper	Rubber Wood	Premium Fiberglass	Synthetic Heads	Hand selected buffalo heads	Natural rawhide	True Skin Buffalo Heads						TTR-Rim
RITUAL DRUMS															
BATAS															
BA1	5 1/4"				X	X		X							072
BA1	8"				X	X		X							072
BA2	5 3/4"				X	X		X							072
BA2	8 3/4"				X	X		X							072
BA3	6 3/4"				X	X		X							072
BA3	12"				X	X		X							072
WOOD CONGUITAS															
HCG89	8"			X		X									073
HCG89	9"			X		X									073
TAMBORA															
MTA1	11"			X				X							073
MTA1	11"			X				X							073
OTHER PARTS															
BEATER (Rattan) for Talking Drum										SPARE-10					072
BEATER (Mahogany Wood) for Talking Drum										SPARE-23					072



MEINL REPLACEMENT PARTS

REPLACEMENT PARTS			
Model No.	Name	Model No.	Page
CAJONS			
			
HEADLINER® SERIES CAJONS			
HCAJ1NT	Frontplate	FP-HCAJ1NT	078
HCAJ3NT	Frontplate	FP-HCAJ3NT	078
HCAJ5NT	Frontplate	FP-HCAJ5NT	078
HCAJ1MH-M	Frontplate	FP-HCAJ1MH-M	078
HCAJ3MH-M	Frontplate	FP-HCAJ3MH-M	078
HCAJ5MH-M	Frontplate	FP-HCAJ5MH-M	078
HCAJ1AWA	Frontplate	FP-HCAJ1AWA	079
HCAJ3AWA	Frontplate	FP-HCAJ3AWA	079
HCAJ5AWA	Frontplate	FP-HCAJ5AWA	079
STRING CAJONS			
CAJ3MB-M	Frontplate	FP-CAJ3MB-M	080
CAJ3BMB-M	Frontplate	FP-CAJ3BMB-M	080
CAJ7NT-BK	Frontplate	FP-CAJ7NT-BK	080
CAJ3AWA	Frontplate	FP-CAJ3AWA	080
CAJ300BU-M	Frontplate	FP-CAJ300BU-M	081
SNARE CAJONS			
CAJ1SNT-M	Frontplate	FP-CAJ1SNT-M	082
CAJ1EB-M	Frontplate	FP-CAJ1EB-M	082
CAJ1CA-M	Frontplate	FP-CAJ1CA-M	082
CAJ2RO-M	Frontplate	FP-CAJ2RO-M	082
CAJ4RO-M	Frontplate	FP-CAJ4RO-M	082
CUSTOM CAJONS			
SUBCAJ1AWA	Frontplate	FP-SUBCAJ1AWA	088
TRECAJ2EB-M	Frontplate	FP-TRECAJ2EB	088
PEDAL CAJONS			
CAJ100BU-M	Frontplate	FP-CAJ100BU-M	083
CAJ5EB-M	Frontplate	FP-CAJ5EB-M	083

OTHER PARTS	
Snare for MEINL Snare Cajon	SPARE-38
Pickup for MEINL Cajon, Shadow	SPARE-39
String for MEINL String Cajon, set of 2 pcs.	SPARE-40
Rubber feet for Cajon incl. Screw, set of 4 pcs.	SPARE-79

REPLACEMENT PARTS									
Model No.	Size	Material	Features	Head	Rim	Lug	Bracket	Page	
FRAME DRUMS									
									
		Hardwood							
		Aluminum							
		Premium Fiberglass							
		Rubber/Wood							
		ABS							
		Steel							
		Counter sunk bolt heads	X						
		Replaceable synthetic heads		X					
		Replaceable goat heads		X					
		Replaceable napa heads		X					
		Height adjustable legs							
		Steel snare wires							
		Floatune Tuning System							
PLENERA SET									
PL-SET	8"			X					
PL-SET	10"			X					
PL-SET	12"			X					
PANDEIROS									
PA10CN-M	10"		X	X	X				
PA10ABS-BK	10"		X	X	X				
PA10ABS-BK-NH	10"		X	X	X				
PA12CN-M	12"		X	X	X				
OTHER PARTS									
Tuning Key for Pandeiro				KEY-08					
Tuning Key for Frame Drums				KEY-11					
Protection Caps for Plenera lugs				CAPS-04					



Model No.	Size	Material	Features	REPLACEMENT PARTS														
				Head	Rim	Lug	Bracket	Page										
																		
FIBERGLASS FAMILY DRUMS																		
HFDD2	8"	Aluminum	Copper	X					HHEADHFDD	HRIMHFDD2	HFDDLUG	HDBRACKET-03	059					
FIBERGLASS DANCING CONGA																		
HC301	8 1/2"			X										HHEAD8,5	HRIM8,5	HDCLUG	HDBRACKET-02	059
FIBERGLASS DANCING DJEMBE																		
HDJ400	12"			X										HHEAD12	HRIM12	HDLUG	HDBRACKET-02	059
FIBERGLASS MINI DANCING DJEMBES																		
HDJ200	8"			X										HHEADDJ8	HRIMDJ8	HD200LUG		059

Model No.	Size	Material	Features	REPLACEMENT PARTS														
				Head	Rim	Lug	Bracket	Page										
																		
HEADLINER® SERIES																		
HT1314, old version	13"			X	X									HEAD-24	RIM-37	LUG-26	BRACKET-18	
HT1314, old version	14"			X	X									HEAD-22	RIM-38	LUG-26	BRACKET-18	
HT1314, 2011 version	13"			X	X									HEAD-24	RIM-37	LUG-44	BRACKET-26	096
HT1314, 2011 version	14"			X	X									HEAD-22	RIM-38	LUG-44	BRACKET-26	096
MARATHON® SERIES																		
MT1415CH + MT1415B	14"			X	X									HEAD-22	RIM-23	LUG-17	BRACKET-12	097
MT1415CH + MT1415B	15"			X	X									HEAD-23	RIM-24	LUG-17	BRACKET-12	097
MT1415BN + MT1415RR-M	14"			X	X									HEAD-22	RIM-27	LUG-17	BRACKET-25	097
MT1415BN + MT1415RR-M	15"			X	X									HEAD-23	RIM-28	LUG-17	BRACKET-25	097
MTT1415	14"			X	X									HEAD-22	RIM-27	LUG-17	BRACKET-25	098
MTT1415	15"			X	X									HEAD-23	RIM-28	LUG-17	BRACKET-25	098
FLOATUNE SERIES																		
TI1BK	13"			X	X		X							HEAD-24	RIM-21	LUG-17		098
TI1BK	14"			X	X		X							HEAD-22	RIM-22	LUG-17		098
ARTIST SERIES, AMADITO VALDÉS																		
AV1BK	14"			X	X		X							HEAD-22	RIM-27	LUG-17		098
AV1BK	15"			X	X		X							HEAD-23	RIM-28	LUG-17		098
ARTIST SERIES, LUIS CONTE																		
LC1BRASS	14"			X	X		X	X	X					HEAD-22	RIM-19	LUG-16	BRACKET-08 brass	099
LC1BRASS	15"			X	X		X	X	X					HEAD-23	RIM-20	LUG-16	BRACKET-09 brass, small	099
LC1STS	14"			X	X		X	X	X					HEAD-22	RIM-19	LUG-16	BRACKET-10 chrome	099
LC1STS	15"			X	X		X	X	X					HEAD-23	RIM-20	LUG-16	BRACKET-11 chrome, small	099
PROFESSIONAL SERIES																		
BT1415	14"		X				X	X	X					HEAD-22	RIM-19	LUG-16	BRACKET-10 chrome	099
BT1415	15"		X				X	X	X					HEAD-23	RIM-20	LUG-16	BRACKET-11 chrome, small	099
DRUMMER SNARE TIMBALES																		
MDST8BK	8"			X	X									HEAD-41	RIM-29	LUG-21	BRACKET-13	102
MDST10BK	10"			X	X									HEAD-42	RIM-30	LUG-21	BRACKET-13	102
DRUMMER TIMBALE																		
MDT13CH	13"			X										HEAD-43	RIM-31	LUG-21	BRACKET-13	102
MINI TIMBALES																		
MIT810CH	8"			X										HEAD-41	RIM-29	LUG-21	BRACKET-13	102
MIT810CH	10"			X										HEAD-42	RIM-30	LUG-21	BRACKET-13	102
ARTIST SERIES, TAKU HIRANO, HAND-BALE																		
MHT13	13"			X										HEAD-43	RIM-47	LUG-21	BRACKET-13	103
ARTIST SERIES, DAVE MACKINTOSH, ATTACK TIMBALE																		
MDT88	8"			X										HEAD-41	RIM-48	LUG-21	BRACKET-13	103

REPLACEMENT PARTS FOR STANDS	
Timbale Stand, chrome	TMT
Cowbell Holder, complete for MEINL Timbales	STAND-01
Cowbell Holder, complete for HT1314 Timbales	HDSTAND-01
Memory Clamp, chrome for middle stand tube	STAND-07
Memory Clamp, black for middle stand tube	STAND-08
Memory Clamp, chrome for lower stand tube	STAND-09
Memory Clamp, black for lower stand tube	STAND-10
Fast Lock Set, chrome	STAND-14
Fast Lock Set, black	STAND-15
Rubber Feet (set of 3 pcs.) for Timbales Stand	STAND-16

OTHER PARTS	
Lug Oil	SPARE-09
Tuning Key, 13 mm + 14 mm, L shaped, chrome	KEY-02



MEINL REPLACEMENT PARTS

Model No.	Size	Material							Features				REPLACEMENT PARTS				Page		
		Hardwood	Aluminum	Premium Fiberglass	Rubber Wood	Poplar Wood	ABS	Steel	Counter sunk bolt heads	Replaceable synthetic heads	Replaceable goat heads	Replaceable nappa heads	Height adjustable legs	Steel snare wires	Floatune Tuning System	Head		Rim	Lug
SAMBA																			
																			
TRADITIONAL ALUMINUM & WOOD SURDOS																			
SU16	16"	X	X					X	X						HEAD-59	RIM-46 (Top)	LUG-37		108
SU18	18"	X	X					X	X						HEAD-49	RIM-40 (Top)	LUG-30		108
SU20	20"	X	X					X	X						HEAD-46	RIM-35 (Top)	LUG-27		108
SU22	22"	X	X					X	X						HEAD-50	RIM-41 (Top)	LUG-31		108
TRADITIONAL STAND ALONE ALUMINUM & WOOD SURDOS																			
SU16-L	16"	X	X					X	X		X				HEAD-59	RIM-46 (Top)	LUG-37		109
SU18-L	18"	X	X					X	X		X				HEAD-49	RIM-40 (Top)	LUG-30		109
SU20-L	20"	X	X					X	X		X				HEAD-46	RIM-35 (Top)	LUG-27		109
SU22-L	22"	X	X					X	X		X				HEAD-50	RIM-41 (Top)	LUG-31		109
BAHIA ALUMINUM SURDOS																			
SUB18	18"		X					X	X						HEAD-49	RIM-40 (Top)	LUG-38		110
SUB20	20"		X					X	X						HEAD-46	RIM-35 (Top)	LUG-39		110
SUB22	22"		X					X	X						HEAD-50	RIM-41 (Top)	LUG-40		110
BAHIA WOOD SURDOS																			
SUB18AB-M	18"	X						X	X						HEAD-49	RIM-40 (Top)	LUG-38		110
SUB20AB-M	20"	X						X	X						HEAD-46	RIM-35 (Top)	LUG-39		110
SUB22AB-M	22"	X						X	X						HEAD-50	RIM-41 (Top)	LUG-40		110
ALUMINUM CAIXAS																			
CA12	12"		X					X	X			X			HEAD-51	RIM-42 (Top)	LUG-33		111
CA14	14"		X					X	X			X			HEAD-52	RIM-43 (Top)	LUG-34		111
TRADITIONAL ALUMINUM CAIXA																			
CA12T	12"		X					X	X			X			HEAD-51	RIM-42 (Top)	LUG-41		111
ALUMINUM REPINIQUES																			
RE10	10"		X					X	X						HEAD-48	RIM-39 (Top)	LUG-29		111
RE12	12"		X					X	X						HEAD-47	RIM-36 (Top)	LUG-28		111
WOOD REPINIQUE																			
RE12AB-M	12"			X				X	X						HEAD-47	RIM-36	LUG-32		111
TIMBAS																			
TIM14	14"				X			X							HEAD-52	RIM-50	LUG-42	BRACKET-23	112
TANTAM																			
TAN14	14"				X					X					HEAD-74	RIM-50	LUG-48	BRACKET-23	112
REBOLO																			
REB12	12"				X					X					HEAD-73	RIM-49	LUG-48	BRACKET-23	112
ALUMINUM CUICAS																			
QW6	6"		X							X					HEAD-57	RIM-44	LUG-35		113
QW10	10"		X					X	X						HEAD-58	RIM-45	LUG-36		113
FIBERGLASS CUICA																			
QW7	8"			X						X			X		HEAD-13	RIM-10	LUG-13		113
TAMPEIRO																			
TP06AB-M	6"			X			X	X	X						HEAD-40	RIM-32	LUG-20		115
SILENT TAMBORIM																			
STBR06	6"					X									HEAD-79	RIM-32	LUG-20		115
FLOATUNE TAMBORIMS																			
TBR06	6"	X	X	X	X	X	X	X	X				X		HEAD-40	RIM-32	LUG-20		115
OTHER PARTS																			
A Go Go Bell Holder												STBAGH							
Tuning Key												KEY-08							
Tuning Key for Caixa												KEY-09							
Tuning Key for Surdo and Repinique												KEY-10							
Beater for Samba Triangle												SPARE-30							
Nappa Heads for Surdo												HEAD-66 = 16" / HEAD-67 = 18" / HEAD-68 = 20" / HEAD-69 = 22"							
Mesh Head for Tamborims												HEAD-79							



DISCLAIMER

All features are subject to change without notice. Not responsible for typographic errors. No part of this book may be reprinted, reproduced, or included in any online service in any form in whole or in part, without the prior permission of MEINL.

© 2013 Roland Meinel Musikinstrumente GmbH & Co. KG

ADVERTISING

CONCEPT & DESIGN BY:

Marcus Beloch, Matthias Mautner
www.ercasdieagentur.de

CONTENT & DIRECTION BY:

Udo Heubeck, Mario Schmitt

MEINL WOULD LIKE TO THANK:

Christian Habermeier, Sebastian Jäger
www.studio-waldeck.de

Sven Mihm
www.mihm-werbung.de

MEINL GLOBAL HEADQUARTERS

Am Bahnhof 2
91468 Gutenstetten
Germany

MEINL USA L.C.

3300 Ambrose Avenue
Nashville, TN 37207
USA

This catalogue has been printed on
FSC certificated paper

Printed in Germany M-CA501212



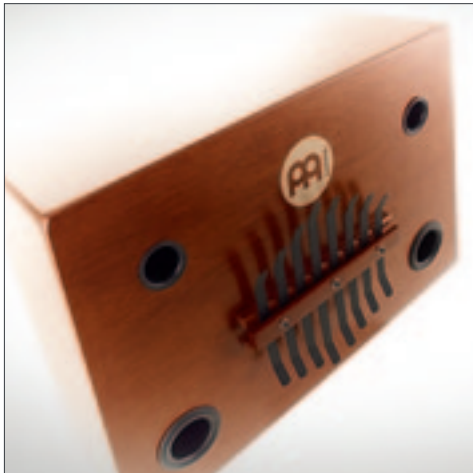

meinlpercussion.com