



**MEINL  
PERCUSSION**

**MEINL  
VIVA  
RHYTHM**



**NINO  
PERCUSSION**

**MEINL  
SONIC  
ENERGY**







**THE MEINL BOOK OF PERCUSSION 2020**





# MEIN PERCUSSION

## B

Bags	96
Blocks	47/67
Bongos	40
Bongo Cajons	10/12
Brushes/Beaters	13/19/84

## C

Cabasas	68
Caixas	65
Cajons	06
Cajons, Bass	11
Cajons, Pickup	04
Cajons, Slaptop	10
Cajons, Snare	08/10/12
Cajons, String	06/12
Cajon Add-Ons	16
Cajon Drum Sets	05/15
Cajon Pedals	13
Candela Percussion Cymbals	83
Castanets	69
Chimes	72
Ching Rings	54
Claves	69
Congas	28
Cowbells	46

## D

Darbukas	76
Didgeridoos	80
Djembes	20
Djembes, Synthetic	20
Djembes, Wood	24
Doumbeks	77

## F

Foot Percussion	18
Frame Drums	74

## G

Güiras/Güiros	67
---------------	----

## H

Hand Drums	74
Hand Percussion	67
Hardware	92

## I

Ibo Drums	78
-----------	----

## J

Jingle Sticks	52
---------------	----

## K

Kalimbas	03/68
----------	-------

## M

Mallets	84
Maracas	61

## P

Pandeiros	48
Pickup Instruments	02

## R

Rainmakers/Rainsticks	82
Ritual Drums	78

## S

Samba	62
Shakers	56/66
Shekeres	79
Sound Effects	70
Stands	86
Sticks/Scrapers	84
Surdos	62

## T

Tables	90
Tamborims/Tampeiro	65
Tambourines	49/56
Timbales	44
Triangles	66/70

# PICKUP INSTRUMENTS

**1** NEW

FIVE DIGITAL PRE-PROGRAMMED PERCUSSION SAMPLES AND ONE CUSTOM SAMPLE

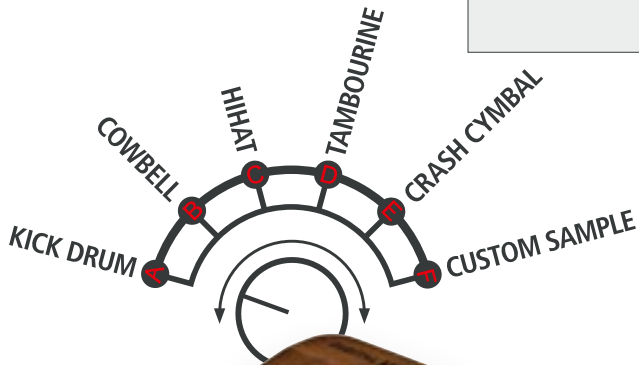

Digital  
**MPDS1**



**NEW**

CREATES A FOOT STOMPING ANALOG SIGNAL



Analog  
**MPS1**

**2** NEW



**MPSM**

**3**

A WHOLE PERCUSSION KIT IN A BOX



10 sound options  
**FX10**

## 1 PERCUSSION STOMP BOXES

- MATERIAL** Solid Mahogany body
- FEATURES** Perfect for percussionists and multi-instrumentalists  
1/4" input and output jacks
- MPDS1**  
Five digital pre-programmed percussion samples and one custom sample  
Built-in Piezo trigger with volume control
- MPS1**  
Creates a foot stomping analog signal  
Built-in Piezo pickups with volume control

## 2 STOMP BOX MOUNT

- MATERIAL** Baltic Birch (*Betula pendula*)
- FEATURES** Play your MEINL Stomp Box with the feel of a bass drum  
Attach any common bass drum pedal  
Use the MEINL L-Shaped beater to get flush contact (model BBB2 – sold separately)  
Works with all MEINL Stomp Boxes  
Baltic birch construction
- FINISH** Black

## 3 FX PEDAL

- MATERIALS** Oak (*Quercus robur*) and steel box
- FEATURES** Microprocessor controls  
10 different sound options  
Sound select button  
Stereo/Mono output  
Made by Shadow
- SOUNDS**  
0 - Kick Bass  
1 - Cyber Kick  
2 - Tribal Bass  
3 - Straight Tambourine  
4 - Double Tambourine  
5 - Clave  
6 - Hand Clap  
7 - Dry Cowbell  
8 - Straight Cabasa  
9 - Double Cabasa
- INCLUDES** Hook and loop fastener with spikes  
International power converter

**4** IMMENSE BASS SOUND



L-SHAPED SOFT FOAM BEATER INCLUDED

Baltic Birch  
**PBASSBOX**

**5** CRISP SNARE SOUND



L-SHAPED FELT BEATER INCLUDED

Baltic Birch  
**PSNAREBOX**



**6** **NEW**



**MIC-PERC**

**7** PICKUP SYSTEM WITH VOLUME CONTROL FROM SHADOW®



Medium  
**KA9P-AB**

**PICKUP BASSBOX AND SNAREBOX 4 5**

**FEATURES** Piezo pickup with high quality output jack  
Playable with our BassBoX/SnareBoX pedal, as well as any other common bass drum pedal  
Aluminum rail to mount any common bass drum pedal  
Forward facing sound port

**COLOUR** Black

**FINISH** Matte

**4 PICKUP BASSBOX**

**SIZE** 17 1/2" W x 6 3/4" H x 11 3/4" D

**MATERIAL** Resonating body: Baltic Birch (*Betula pendula*)

**FEATURE** Immense bass sound that's perfect for any musician, including singer/songwriters and guitarists

**INCLUDES** L-shaped soft foam beater

**5 PICKUP SNAREBOX**

**SIZE** 7 1/2" W x 7 1/2" H x 13" D

**MATERIAL** Baltic Birch (*Betula pendula*)

**FEATURE** Crisp snare sound that's perfect for any musician, including singer/songwriters and guitarists

**INCLUDES** L-shaped felt beater

**6 PERCUSSION MICROPHONE**

**FEATURES** Low-profile condenser microphone with adhesive backing  
Safely and securely sticks to the inside of acoustic percussion instruments  
Great for cajons, congas, djembes or frame drums  
Includes eighth-inch cable to quarter-inch adapter

**7 PICKUP KALIMBA**

**SIZE** Medium

**MATERIALS** Chrome plated steel  
Siam Oak (*Hevea brasiliensis* Muell.-Arg.)

**TUNING** a' c'' c' a' A f' e' e'' b'

**FEATURES** Pickup system with external volume control  
Wah-wah effect

**COLOUR** **AB:** African Brown

# PICKUP CAJONS

**1** **NEW** PIEZO PICKUP WITH VOLUME AND TONE CONTROL



**SOLEÁ LINE**

Dark Olive Burst  
**PAESLDOB**

**2**



Makah-Burl  
**PWCP100MB**

Baltic Birch  
**PSC100B**

**3** PIEZO PICKUP WITH VOLUME AND TONE CONTROL



Baltic Birch  
**PSUBCAJ6B**

**VERTICAL FORWARD-FACING SUBWOOFER SOUND PORTS**

**4** PASSIVE PICKUP SYSTEM WITH HIGH QUALITY OUTPUT JACK



Walnut  
**PTOPCAJ2WN**

**THE PICKUP TURBO SLAPTOP CAJON IS BIGGER FOR MORE VOLUME**

INDIVIDUAL SNARE, BASS, AND TONE CONTROL



Mahogany  
**PTOPCAJ4MH-M**

## 1 ARTISAN EDITION PICKUP CAJON, SOLEÁ LINE

**SIZE** 11 1/4" W x 19" H x 11 3/4" D  
**MATERIALS** Resonating body: 9-Ply (12 mm) Baltic Birch (*Betula Pendula*)  
 Frontplate: Dark Olive Burst  
**FEATURES** Piezo pickup with volume and tone control; Two sets of 4 pre-tuned strings; Rounded corners and thumb notches for optimal playing comfort and sound; Ergonomically rounded frontplate with convex contact; Bass reflex system

## 2 PICKUP CAJONS

**SIZES** **PSC100B** (Snarecraft) 11 3/4" W x 19 3/4" H x 11 3/4" D  
**PWCP100MB** (Woodcraft Professional) 11 3/4" W x 19 3/4" H x 12" D  
**MATERIALS** Resonating body: Baltic Birch (*Betula pendula*)

## PSC100B (Snarecraft)

Frontplate: Baltic Birch (*Betula pendula*)

**PWCP100MB** (Woodcraft Professional)

Frontplate: Makah-Burl

**FEATURES** Three Piezo pickups for snare and bass sounds; Rubber feet and rear sound port

**PSC100B** (Snarecraft)

Dual internal fixed snare wires

**PWCP100MB** (Woodcraft Professional)

Custom Micro-Coiled Steel Cajon Strings

## 3 PICKUP VERTICAL SUBWOOFER CAJON

**SIZE** 15 1/2" W x 19 1/4" H x 11 3/4" D

**MATERIALS** Resonating body: Eco-friendly medium density fiberboard

Frontplate: Baltic Birch (*Betula pendula*)

**FEATURES** Vertical forward-facing subwoofer sound ports for enhanced bass notes; Piezo pickup with volume and tone control;

Dual internal fixed snare wires

## 4 PICKUP SLAPTOP CAJONS (PATENTED)

**SIZES** **PTOPCAJ2WN** (Turbo Slaptop) 14 1/2" W x 10" H x 5 3/4" D

**PTOPCAJ4MH-M**

15 1/2" W x 8 1/2" H x 7 1/2" D

**MATERIALS** **PTOPCAJ2WN** (Turbo Slaptop)

Resonating body: Baltic Birch

(*Betula pendula*)

Playing surface: Walnut (*Juglans regia* L.)

**PTOPCAJ4MH-M**

Resonating body: Eco-friendly medium

density fiberboard

Playing surface: Mahogany

**FEATURES** Passive pickup system with high quality output jack; Individual snare, bass, and tone control; Playing surface with dual internal fixed snare wires; Forward facing sound ports

**PTOPCAJ2WN** (Turbo Slaptop)

Snares on both sides

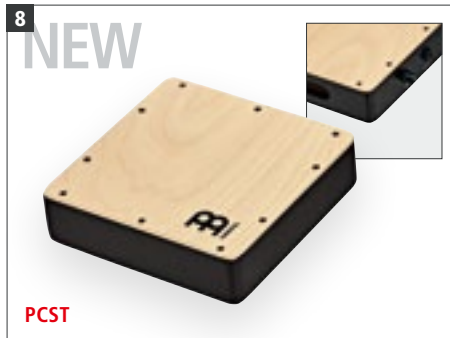

**5 COCKTAIL CAJON KIT**

**CONTAINS** Cocktail Cajon; Tom Tap incl. new L-rod; Snare Tap incl. new L-rod; Bongo Cajon Tap incl. new L-rod; SB307 Husk Brush; TMBP Foot Pedal; CPB4 Pedal Beater

**FEATURES** Create cocktail-style cajon kit or percussion set ups; Each drum is equipped with a Piezo pickup and high-quality output jack

**6 COCKTAIL CAJON**

**SIZE** 11 3/4" W x 19 3/4" H x 11 3/4" D

**MATERIALS** Resonating body: 7-Ply (9 mm) Baltic Birch (*Betula pendula*)  
Frontplate: Baltic Birch (*Betula pendula*)

**FEATURES** Baltic birch cajon with forward facing ports and no snares for more bass; Bass drum pedal mount; Three clamps to attach percussion rods or cymbal arms (rods and arms sold separately); Piezo pickups for extra amplification

**7 PICKUP BONGO CAJON**

**MATERIAL** Baltic Birch (*Betula pendula*)

**FEATURES** High and low note playing areas; Piezo pickup and quarter-inch output jack

**PICKUP CAJON TAPS 8 9**

**SIZE** 10 3/4"

**MATERIAL** Baltic Birch (*Betula pendula*)

**FEATURES** Piezo pickup, quarter-inch output jack and volume knob; Standard eye bolt mount to add to your cajon set up or percussion rig; Ideal for acoustic shows

**8 PICKUP CAJON SNARE TAP**

**FEATURE** Hollow wooden body with internal snare produces a crisp snare drum sound

**9 PICKUP CAJON TOM TAP**

**FEATURE** Hollow wooden body produces a high-pitched tom sound

**10 MINI CAJON SPEAKER**

**SIZE** 5 3/4" W x 8 3/4" H x 5 3/4" D

**MATERIALS** Resonating body: 5-Ply (6 mm) Baltic Birch (*Betula pendula*)  
Frontplate: Baltic Birch (*Betula pendula*)

**FEATURES** Miniature MEINL cajon that functions as a speaker; Listen to your favorite music or podcast; Supports wireless, USB and auxiliary connection; Great gift idea for percussionists

**11 CAJON PREAMP**

**FEATURES** Robust Cajon Pickup/Preamp; Wide range tone control; High-quality signal output; Fits most cajons

**12 CAJON MICROPHONE STAND**

**MATERIAL** Black powder coated aluminum

**FEATURES** Round base for compact setup; Solid construction; Height adjustable

# ARTISAN EDITION CAJONS

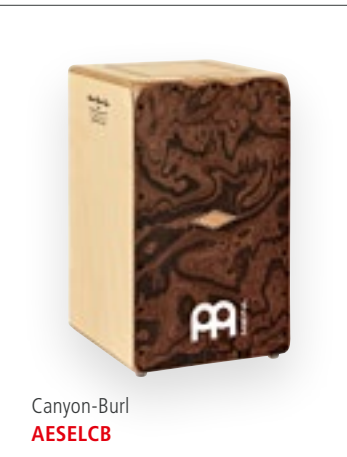

## ARTISAN EDITION CAJONS

**1 2 3 4 5 6 7**

**FEATURES** Rounded corners and thumb notches for optimal playing comfort and sound  
Ergonomically rounded frontplate with convex contact  
**Martinete, Fandango, Seguriya, Cantina Line:**  
Decorative wood inlay  
Extra thick wooden sound port ring for compression  
Two tuning screws to adjust the tension for each set of strings  
Pop filter on soundhole  
**Seguriya, Cantina, Soleá, Bulería, Tango Line:**  
Elegant heat-branding on resonating body  
**FINISH** Satin

### 1 MARTINETE LINE

**SIZE** 11 1/2" W x 19" H x 12 3/4" D  
**MATERIALS** Resonating body: Solid Wood (15 mm)  
Tulip Poplar (*Liriodendron tulipifera*)  
Frontplate: Brazilian Ironwood (*Phoebe porosa*) with Ukola Woodframe  
**FEATURES** Two sets of 10 adjustable strings (Separately per side)  
6 specially formulated soft rubber feet  
**INCLUDES** Tuning key

### 2 FANDANGO LINE

**SIZE** 11 1/2" W x 19" H x 12" D  
**MATERIALS** Resonating body: Solid Wood (15 mm)  
Tulip Poplar (*Liriodendron tulipifera*)  
Frontplate: Indian Heartwood  
**FEATURES** Two sets of 8 adjustable strings (Separately per side)  
6 specially formulated soft rubber feet  
**INCLUDES** Tuning key

### 3 SEGURIYA LINE

**SIZE** 11 1/4" W x 19" H x 11 3/4" D  
**MATERIALS** Resonating body: 9-Ply (12 mm)  
Baltic Birch (*Betula Pendula*)  
**AESELCB** Frontplate: Canyon-Burl  
**AESELIH** Frontplate: Indian Heartwood  
**FEATURES** Two sets of 8 adjustable strings (Separately per side)  
4 specially formulated soft rubber feet  
**INCLUDES** Tuning key

### 4 CANTINA LINE

**SIZE** 12 1/2" W x 18 1/2" H x 12 1/2" D  
**MATERIALS** Resonating body: 9-Ply (12 mm)  
Baltic Birch (*Betula Pendula*)  
Frontplate: Walnut  
**FEATURES** Two sets of 8 adjustable strings from the top (Separately per side)  
4 specially formulated soft rubber feet  
**INCLUDES** Tuning key

# WOODCRAFT CAJONS



8

DETAILED WITH SILK SCREEN PRINTED LOGO



Mahogany  
**WCP100MH**



Makah-Burl  
**WCP100MB**

9

ROUNDED CORNERS FOR ADDED COMFORT



Baltic Birch  
**WC100B**



Espresso Burst  
**WC100EB**

## 5 BULERÍA LINE

- SIZE** 11 1/4" W x 19" H x 11 3/4" D
- MATERIALS** Resonating body: 9-Ply (12 mm) Baltic Birch (*Betula Pendula*)  
**AEBLLB** Frontplate: Lava-Burl  
**AEBLMY** Frontplate: Mongoy
- FEATURES** Two sets of 5 adjustable strings (Separately per side)  
Tuning screw to adjust string tension  
Pop filter on soundhole  
Bass reflex system  
4 specially formulated soft rubber feet
- INCLUDES** Tuning key

## 6 SOLEÁ LINE

- SIZE** 11 1/4" W x 19" H x 11 3/4" D
- MATERIALS** Resonating body: 9-Ply (12 mm) Baltic Birch (*Betula Pendula*)  
**AESLEB** Frontplate: Espresso Burst  
**AESLEYB** Frontplate: Ebony Burst  
**AESLRB** Frontplate: Dark Red Burst
- FEATURES** Two sets of 4 pre-tuned strings  
Bass reflex system  
4 specially formulated soft rubber feet

## 7 TANGO LINE

- SIZE** 11 1/4" W x 19" H x 11 3/4" D
- MATERIALS** Resonating body: 7-Ply (9 mm) Baltic Birch (*Betula Pendula*)  
**AETLLE** Frontplate: Light Eucalyptus  
**AETLLI** Frontplate: Limba
- FEATURES** Two sets of 3 pre-tuned strings  
4 specially formulated soft rubber feet

## WOODCRAFT CAJONS 8 9

- SIZE** 11 3/4" W x 19 3/4" H x 12" D
- FEATURES** Custom micro-coiled steel cajon strings  
Baltic birch construction  
Rounded corners for added comfort  
Rubber feet and rear sound port

## 8 WOODCRAFT PROFESSIONAL CAJONS

- MATERIALS** Resonating body: 9-Ply (12 mm) Baltic Birch (*Betula pendula*)  
**WCP100MB** Frontplate: Makah-Burl  
**WCP100MH** Frontplate: Mahogany

## 9 WOODCRAFT CAJONS

- MATERIALS** Resonating body: 7-Ply (9 mm) Baltic Birch (*Betula pendula*)  
**WC100B** Frontplate: Baltic Birch (*Betula pendula*)  
**WC100EB** Frontplate: Espresso Burst

# SNARECRAFT CAJONS

**1** FOOT ACTIVATED SNARE SWITCH



American White Ash  
**SCP100AWA**

SNARE SWITCH KNOB



Walnut  
**SCP100WN**

**2**



Almond Birch  
**SC80AB**

Almond Birch  
**SC100AB**



Baltic Birch  
**SC80AB-B**

Baltic Birch  
**SC100AB-B**



Baltic Birch  
**SC80B**

Baltic Birch  
**SC100B**



Dark Eucalyptus  
**SC80DE**

Dark Eucalyptus  
**SC100DE**



SC80 HEIGHT 18"  
SC100 HEIGHT 19 3/4"



Heart Ash  
**SC80HA**

Heart Ash  
**SC100HA**

**1 SNARECRAFT PROFESSIONAL CAJONS**

**SIZE** 11 3/4" W x 19 3/4" H x 12" D

**MATERIALS** Resonating body: 9-Ply (12 mm)  
Baltic Birch (*Betula pendula*)  
**SCP100AWA**  
Frontplate: American White Ash (*Fraxinus Americana* L.)  
**SCP100WN**  
Frontplate: Walnut

**FEATURES** Adjustable snare for both Flamenco and Peruvian styles  
Baltic birch construction  
Rounded corners for added comfort  
Rubber feet and rear sound port  
**SCP100AWA**  
Equipped with a foot activated snare switch  
**SCP100WN**  
Equipped with a snare switch knob on the side of the cajon

**2 SNARECRAFT CAJONS**

**SIZES** **SC80:** 11 3/4" W x 18" H x 11 3/4" D  
**SC100:** 11 3/4" W x 19 3/4" H x 11 3/4" D

**MATERIALS** **SC80AB, SC100AB**  
Resonating body: 7-Ply (9 mm)  
Baltic Birch (*Betula pendula*)  
Frontplate: Almond Birch (*Betula pendula*)  
**SC80AB-B, SC100AB-B**  
Resonating body: 7-Ply (9 mm)  
Almond Birch (*Betula pendula*)  
Frontplate: Baltic Birch (*Betula pendula*)  
**SC80B, SC100B**  
Resonating body: 7-Ply (9 mm)  
Baltic Birch (*Betula pendula*)  
Frontplate: Baltic Birch (*Betula pendula*)  
**SC80DE, SC100DE**  
Resonating body: 7-Ply (9 mm)  
Baltic Birch (*Betula pendula*)  
Frontplate: Dark Eucalyptus

**SC80HA, SC100HA**  
Resonating body: 7-Ply (9 mm)  
Baltic Birch (*Betula pendula*)  
Frontplate: Heart Ash  
**FEATURES** Dual internal fixed snare wires  
Baltic birch construction  
Rounded corners for added comfort  
Rubber feet and rear sound port

# JAM & MINI CAJONS



SNARE CAJONS

1



Almond Birch  
**JC50AB**



Baltic Birch  
**JC50AB-B**



Baltic Birch  
**JC50B**



Dark Eucalyptus  
**JC50DE**

JC50 HEIGHT 15"



Heart Ash  
**JC50HA**

2



Almond Birch  
**MC1AB**



Baltic Birch  
**MC1AB-B**



Baltic Birch  
**MC1B**



Dark Eucalyptus  
**MC1DE**

MC1 HEIGHT 8 3/4"



Heart Ash  
**MC1HA**

## 1 JAM CAJONS

**SIZE** 10 1/2" W x 15" H x 10 1/4" D

**MATERIALS** **JC50AB**

Resonating body: 7-Ply (9 mm)

Baltic Birch (*Betula pendula*)

Frontplate: Almond Birch

(*Betula pendula*)

**JC50AB-B**

Resonating body: 7-Ply (9 mm)

Almond Birch (*Betula pendula*)

Frontplate: Baltic Birch (*Betula pendula*)

**JC50B**

Resonating body: 7-Ply (9 mm)

Baltic Birch (*Betula pendula*)

Frontplate: Baltic Birch (*Betula pendula*)

**JC50DE**

Resonating body: 7-Ply (9 mm)

Baltic Birch (*Betula pendula*)

Frontplate: Dark Eucalyptus

## JC50HA

Resonating body: 7-Ply (9 mm)

Baltic Birch (*Betula pendula*)

Frontplate: Heart Ash

### FEATURES

Compact size

Baltic birch construction

Dual internal fixed snare wires

Rubber feet and rear sound port

## 2 MINI CAJONS

**SIZE** 5 3/4" W x 8 3/4" H x 5 3/4" D

**MATERIALS** **MC1AB**

Resonating body: 5-Ply (6 mm)

Baltic Birch (*Betula pendula*)

Frontplate: Almond Birch

(*Betula pendula*)

**MC1AB-B**

Resonating body: 5-Ply (6 mm)

Almond Birch (*Betula pendula*)

Frontplate: Baltic Birch (*Betula pendula*)

## MC1B

Resonating body: 5-Ply (6 mm)

Baltic Birch (*Betula pendula*)

Frontplate: Baltic Birch (*Betula pendula*)

### MC1DE

Resonating body: 5-Ply (6 mm)

Baltic Birch (*Betula pendula*)

Frontplate: Dark Eucalyptus

### MC1HA

Resonating body: 5-Ply (6 mm)

Baltic Birch (*Betula pendula*)

Frontplate: Heart Ash

### FEATURES

Internal fixed snare wires

Miniature size

Birch construction

Great gift idea

# SLAPTOP, BONGO & TRAVEL CAJONS

1 NEW

VIDALITA LINE



Palo Santo, satin  
**AEVLPS**

2

COMFORTABLE DESIGN FOR A MORE UPRIGHT PLAYING STYLE (PATENTED)



Makah-Burl, matte  
**TOPCAJ1MB**



Espresso Burst, matte  
**TOPCAJ1EB**

3

CONTRASTING PLAYING SURFACES ON OPPOSITE SIDES



Baltic Birch, matte  
**HTOPCAJ3NT**



2

THE TURBO SLAPTOP CAJONS ARE BIGGER FOR MORE VOLUME



Walnut, matte  
**TOPCAJ2WN**



Mahogany, matte  
**TOPCAJ2MH**

4

INTERNAL SNARE WIRES



Natural/Ebony Black, matte  
**BCA2NT/EBK-M**

TWO DIFFERENT SIZED CHAMBERS ENABLE AN AUTHENTIC BONGO EFFECT



Super Natural, matte  
**BCA1SNT-M**

5

BACK

SOUND PORT FOR CLEAR PROJECTION



Black, matte  
**TCAJ1BK**

## 1 ARTISAN EDITION SLAPTOP CAJON, VIDALITA LINE

- SIZE** 17 3/4" W x 10" H x 12 1/2" D
- MATERIALS** Resonating body: 6 mm birch plywood; Playing surface: Palo Santo (*Bursera graveolens*)
- FEATURES** Enlarged Baltic Birch body with upward facing front port for deep bass; Eight pre-tuned custom micro-coiled steel cajon strings; Palo Santo playing surface with sensitive snare effect; Made in Spain

## 2 SLAPTOP CAJONS (PATENTED)

- SIZES** **TOPCAJ1**  
14 1/2" W x 8 3/4" H x 5 3/4" D  
**TOPCAJ2** (Turbo Slaptop)  
14 1/2" W x 10" H x 5 3/4" D

## MATERIALS TOPCAJ1EB

Resonating body: Baltic Birch (*Betula pendula*); Playing surface: Espresso Burst

## TOPCAJ1MB

Resonating body: Eco-friendly medium density fiberboard;

Playing surface: Makah-Burl

**TOPCAJ2MH** (Turbo Slaptop)  
Resonating body: Baltic Birch (*Betula pendula*); Playing surface: Mahogany

**TOPCAJ2WN** (Turbo Slaptop)  
Resonating body: Eco-friendly medium density fiberboard;

Playing surface: Walnut (*Juglans regia* L.)

## FEATURES

- Comfortable upright playing style;
- Forward facing sound ports;
- Dual internal fixed snare wires;
- Deep bass and cutting slap tones
- TOPCAJ2** (Turbo Slaptop)  
Snares on both sides

## 3 HYBRID SLAPTOP CAJON

- SIZE** 14 1/2" W x 10" H x 5 3/4" D
- MATERIAL** Baltic Birch (*Betula pendula*)
- FEATURES** Comfortable and unique X-design; Forward sound projection; Dual internal fixed snare wires for a snare cajon sound on one side; Bongo cajon sound on the opposite side

## 4 BONGO CAJONS

- SIZE** 15 3/4" W x 6 3/4" H x 7 1/4" D
- MATERIAL** Siam Oak (*Hevea brasiliensis* Muell.-Arg.)
- FEATURES** High and low pitch playing surface; Compact size and light weight  
**BCA2NT/EBK-M**: Dual internal fixed snare wires

## 5 TRAVEL CAJON

- SIZE** 11 3/4"
- MATERIAL** Siam Oak (*Hevea brasiliensis* Muell.-Arg.)
- FEATURES** Internal snare wires; Compact design

# BASS CAJONS



CAJONS

## 1 JUMBO ARCH BASS CAJON

**SIZE** 16" W x 19 3/4" H x 13 1/2" D  
**MATERIALS** Resonating body: Siam Oak (*Hevea brasiliensis* Muell.-Arg.); Frontplate: Maple  
**FEATURES** Arched sides and back for low note development; Extra wide dimensions; Dual internal fixed snare wires; Enhanced boomy and punchy bass sounds

## 2 ARCH BASS CAJON

**SIZE** 15 1/4" W x 18" H x 12" D  
**MATERIALS** Resonating body: Siam Oak (*Hevea brasiliensis* Muell.-Arg.); Frontplate: Maple  
**FEATURES** Arched sides for low note development; Extra wide dimensions; Dual internal fixed snare wires

## 3 EBONY BASS FOOT SWITCH CAJON

**SIZE** 13 1/4" W x 19 3/4" H x 13 1/2" D  
**MATERIALS** Resonating body: Baltic Birch (*Betula pendula*); Frontplate: Ebony  
**FEATURES** Foot activated snare switch; Extra wide body for deep bass

## 4 MAPLE BASS CAJON

**SIZE** 13 1/2" W x 19 1/4" H x 14" D  
**MATERIALS** Resonating body: Eco-friendly medium density fiberboard; Frontplate: Maple  
**FEATURES** Jumbo bass size for optimal low notes; Dual internal fixed sets of snare wires

## 5 VERTICAL SUBWOOFER CAJON

**SIZE** 15 1/2" W x 19 1/4" H x 11 3/4" D  
**MATERIALS** Resonating body: Eco-friendly medium density fiberboard; Frontplate: Makah-Burl

**FEATURES** Vertical forward facing sound ports; Dual internal fixed snare wires and bass reflex channel; Responsive Makah-Burl frontplate; Enhanced bass notes

## 6 SUBWOOFER CAJONS

**SIZES** **SUBCAJ1AWA** 11 3/4" W x 19 3/4" H x 12 1/4" D  
**SUBCAJ5WN** 13 1/2" W x 19 3/4" H x 13 3/4" D  
**MATERIALS** Resonating body: Eco-friendly medium density fiberboard  
**SUBCAJ1AWA** Frontplate: American White Ash (*Fraxinus Americana* L.)  
**SUBCAJ5WN** Frontplate: Walnut (*Juglans regia* L.)  
**FEATURES** Super low frequency; Forward projecting sound port; Dual internal fixed snare wires; Adjustable top corners

# HEADLINER® SERIES & MAKE YOUR OWN CAJONS

**1** **ANTI-SLIP SITTING SURFACE**



Siam Oak  
**HCAJ1NT**

**ADJUSTABLE SIZZLE EFFECT**



Stained American White Ash  
**HCAJ1AWA**

**ECO-FRIENDLY MEDIUM DENSITY FIBERBOARD**

**2**



Maple  
**MCAJ100BK-MA**



**3** **ALL NEEDED TOOLS INCLUDED**



Burl Wood  
**DMYO-CAJ-BU**

**DELUXE MODEL FEATURES LARGER SIZE**

**4**



Baltic Birch  
**MYO-CAJ**

**5**



Baltic Birch  
**MYO-BCAJ**

**6**



**MYO-TOOLS**

**4**



Ovangkol  
**MYO-CAJ-OV**

**ASSEMBLY INSTRUCTION COMES IN DIFFERENT LANGUAGES**

## 1 HEADLINER® SERIES STRING CAJONS

**SIZE** 11 3/4" W x 18" H x 12 1/4" D

**MATERIALS** **HCAJ1AWA**

Resonating body: Eco-friendly medium density fiberboard  
Frontplate: Stained American White Ash (*Fraxinus Americana* L.)

**HCAJ1NT**

Resonating body: Siam Oak (*Hevea brasiliensis* Muell.-Arg.)  
Frontplate: Siam Oak (*Hevea brasiliensis* Muell.-Arg.)

**FEATURES** Adjustable top corners; Adjustable sizzle effect; Anti-slip sitting surface; Wide sound options

**INCLUDES** Hex key

**FINISH** Matte

**MATERIALS** Resonating body: Eco-friendly medium density fiberboard  
Frontplate: Maple

**FEATURES** Dual internal fixed snare wires; Adjustable top corner; Wide sound options

**FINISH** Matte

## MAKE YOUR OWN 3 4 5

**CONTAINS** All of the materials and assembly instructions for completing the cajon

## 3 DELUXE MAKE YOUR OWN CAJON

**SIZE** 12" W x 19 1/4" H x 12" D

**MATERIALS** Resonating body: Baltic Birch (*Betula pendula*)

Frontplate: Burl Wood

**INCLUDES** All of the tools for completing the cajon

**MATERIALS** Resonating body: Baltic Birch (*Betula pendula*)

**MYO-CAJ**

Frontplate: Baltic Birch (*Betula pendula*)

**MYO-CAJ-OV**

Frontplate: Ovangkol (*Guibourtia ehie*)

Steel snare wires

**COLOUR** Natural

## 5 MAKE YOUR OWN BONGO CAJON

**SIZE** 15 3/4" W x 6 3/4" H x 7 1/4" D

**MATERIAL** Baltic Birch (*Betula pendula*)

**COLOUR** Natural

## 6 MAKE YOUR OWN CAJON TOOL BOX

**FEATURE** One-stop shop for all necessary tools to complete the MEINL Make Your Own Cajons and Bongo Cajon

**CONTAINS** 1 x screwdriver; 1 x wood glue; 2 x tension straps; 2 x sanding pads (coarse and fine)



# CAJON PEDALS



CAJONS & CAJON PEDALS

**1**

EASILY PLAY DOUBLE BASS PATTERNS ON YOUR CAJON



**TMDCP**

**2**

SPECIALLY POSITIONED CURVED STEEL BAR WITH DIRECT DRIVE



**TMSTCP**

**3**

ADJUSTABLE SPRING TENSION ON BOTH THE PEDAL AND THE MOUNT



**TMCP**

**4**

CAN BE PLAYED WITH YOUR HEEL OR TOES

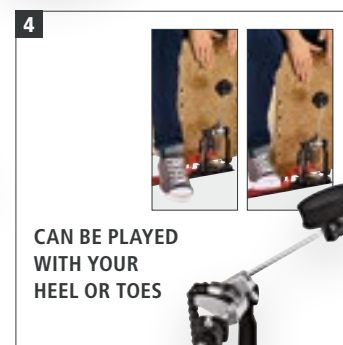

**TMSTCP-2**

BASSBOX/ SNAREBOX PEDAL (SEE PAGE 19)

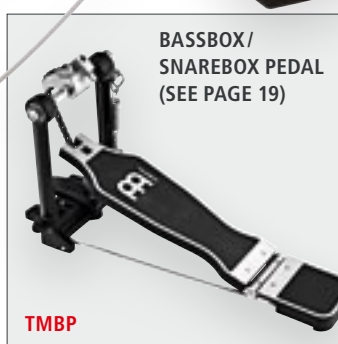

**TMBP**

**5**

FOR PRONOUNCED KICK SOUND

Foam rubber



**CPB1**

**6**

ADJUSTABLE BRASS JINGLES



Soft foam

**CPB2**

**7**

DELIVERS HEAVY, FULL STROKES



Polymer bristles

**CPB3**

**8**

FOR DEEP AND PUNCHY NOTES



Soft foam

**CPB4**

**9**

GREAT FOR LOW VOLUME SETTINGS



Artificial fur

**CPB5**

**1 DOUBLE BASS DIRECT DRIVE CAJON PEDAL**

**MATERIAL** Steel

**FEATURES** Easily play double bass patterns on your cajon; Two pedals connected into one unit; Direct drive system provides a smooth, responsive feel; Adjustable spring tension; Cradle-like mount fits any common cajon and keeps the pedals secure

**INCLUDES** Drum key

**2 DIRECT DRIVE CAJON PEDAL**

**MATERIAL** Steel

**FEATURES** Cradle-like mount fits all common cajons; Adjustable spring tension; Natural foot position for ease of use

**3 CAJON PEDAL**

**MATERIALS** Steel; Plastic

**FEATURES** Cradle-like mount fits all common cajons; Ultra-smooth and durable cable; Position anywhere for optimal playability

**INCLUDES** Drum key; Soft foam beater

**4 DIRECT DRIVE HEEL ACTIVATED CAJON PEDAL**

**MATERIAL** Steel

**FEATURES** Simple design for steady bass drum rhythms; Cradle-like mount fits most cajons

**INCLUDES** Drum key

**5 HAMMER HEAD CAJON & BASS DRUM BEATER**

**MATERIAL** Foam rubber

**FEATURES** Soft foam rubber draws a deep bass sound from cajons; Dual playing surfaces for a variety of boom and punch

**6 JINGLE CONTACT CAJON & BASS DRUM BEATER**

**MATERIALS** Soft foam rubber; Brass jingles

**FEATURES** Easily turn the jingles on or off as desired throughout your set

**7 BRUSH CAJON & BASS DRUM BEATER**

**MATERIAL** Rippled polymer bristles

**FEATURES** Extra thick set of wavy polymer bristles; Two adjustable control rings; Warm, slightly mellow attack

**8 STANDARD CAJON & BASS DRUM BEATER**

**MATERIAL** Soft foam rubber

**9 BLACK SHEEP CAJON BEATER**

**MATERIALS** Artificial fur; Soft foam

# CAJON DRUM SET STANDS & CAJON TAPS

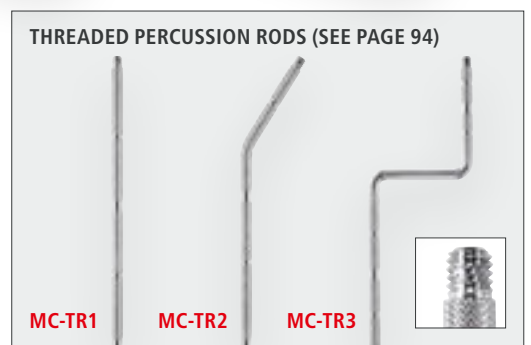
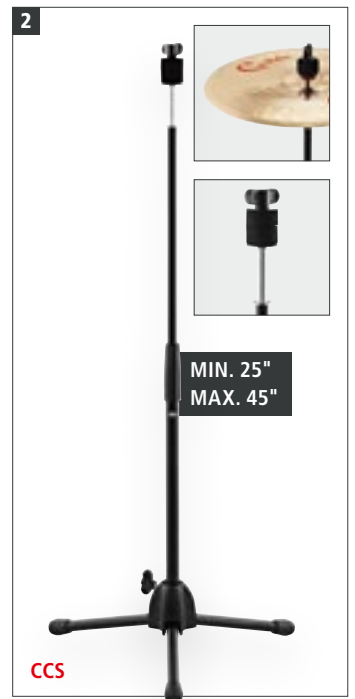
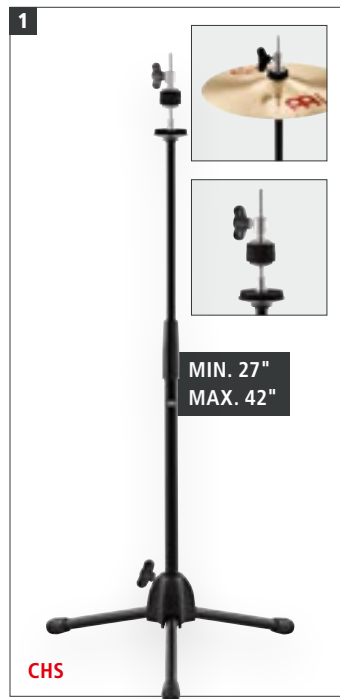

## CAJON DRUM SET STANDS 1 2 3

**MATERIAL** Black powder coated aluminum  
**FEATURE** Foldable legs, height adjustable

### 1 CAJON HIHAT STAND

**FEATURES** Standard hihat clutch and padded seat  
Fixed internal rod for closed hihat sound

### 2 CAJON CYMBAL STAND

**FEATURES** Standard cymbal stand top  
Use with any cymbal type

### 3 CAJON ADD-ON STAND

**FEATURES** 3/8" threaded connector top  
Perfect for the MEINL Cajon Taps or Mountable Cajon Snare

## CAJON TAPS 4 5 6

**SIZE** 5 3/4"  
**MATERIAL** Siam Oak (*Hevea brasiliensis* Muell.-Arg.)  
**FEATURES** Threaded 3/8" connection underneath  
Mountable on the MEINL Cajon Add-On Stand  
**FINISH** Black

### 4 CAJON JINGLE TAP

**FEATURE** Stainless steel jingles for bright accents

### 5 CAJON SNARE TAP

**FEATURE** Internal snares for high pitched snare cajon sound

### 6 CAJON TOM TAP

**FEATURE** Hollow inside for a high pitched "tom" sound

## 7 MOUNTABLE CAJON SNARE WITH THREADED 3/8" CONNECTION

**SIZE** 7 1/2"  
**MATERIAL** Siam Oak (*Hevea brasiliensis* Muell.-Arg.)  
**FEATURES** Internal Snare Wires  
Threaded 3/8" connection to mount on the MEINL Cajon Add-On Stand  
Great auxiliary snare option for cajon players who want to expand their grooves  
**INCLUDES** Silicone Protection Cover  
**COLOUR** BK: Black

# CAJON DRUM SETS

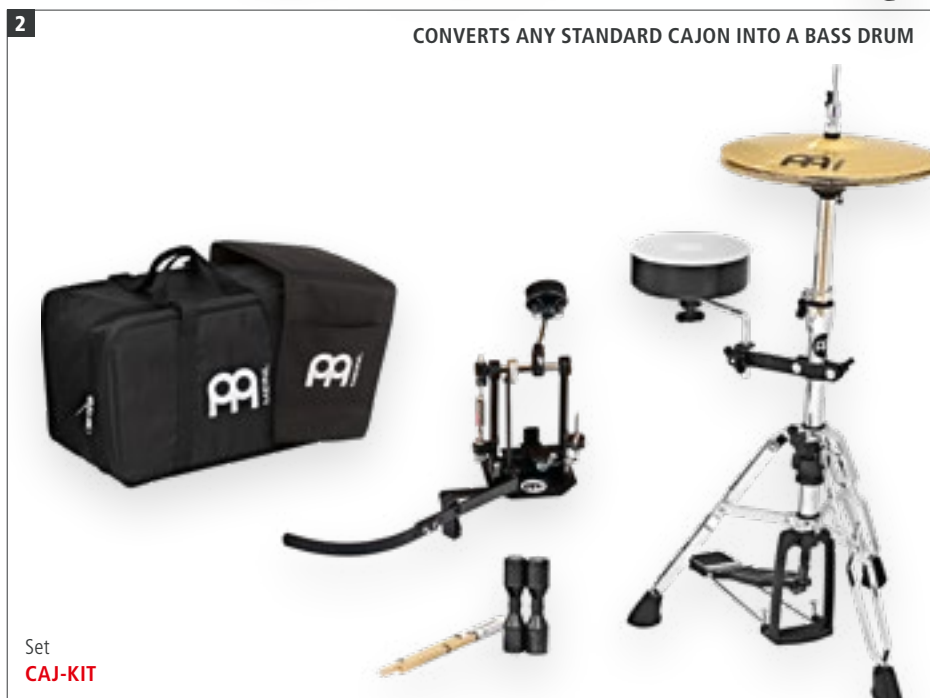
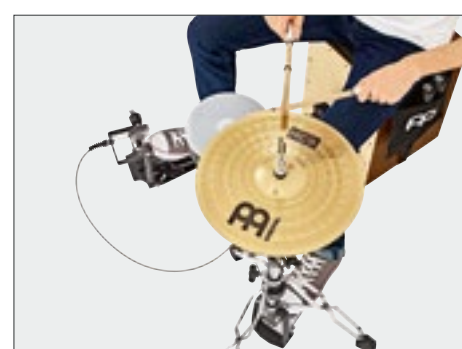
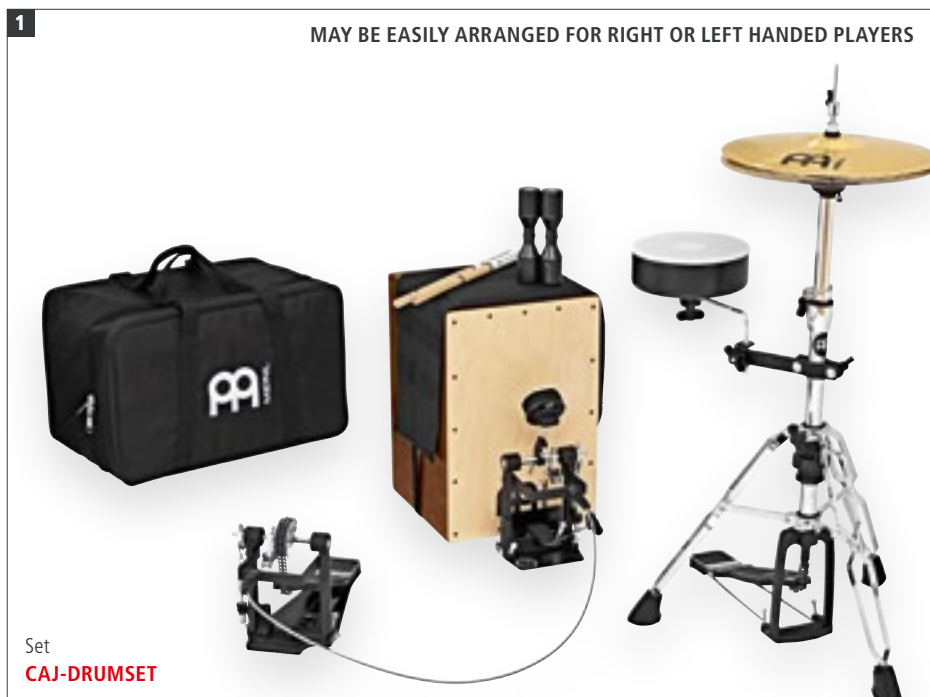

**1 CAJON DRUM SET**

**CONTAINS** Birch wood cajon without snares for enhanced bass  
Cajon Pedal  
Mountable Cajon Snare including silicone protection cover  
Multi-Clamp  
HCS 13" hihat cymbal pair with Low Hat  
Bamboo Flex Multi-Rods for Cajon  
Cajon Blanket with pockets for accessories  
Luis Conte Live Shaker  
Cajon Gig Bag

**FEATURES** May be easily arranged for right or left handed players  
This set includes everything needed for players looking to perform their normal drum set rhythms in smaller, intimate acoustic settings  
The elements of this set give you the same feeling as sitting down at a drum kit

**2 CAJON DRUM SET CONVERSION KIT**

**CONTAINS** Direct Drive Cajon Pedal  
Mountable Cajon Snare including silicone protection cover  
Multi-Clamp  
HCS 13" hihat cymbal pair with Low Hat  
Bamboo Flex Multi-Rods for Cajon  
Cajon Blanket with pockets for accessories  
Luis Conte Live Shaker  
Cajon Gig Bag

**FEATURES** Converts any standard cajon into a bass drum (cajon not included)  
Expand your cajon into a small, reduced volume drum set  
Low-key stage footprint  
Perfect for acoustic shows, jam sessions, or street performances

**3 MOUNTABLE CAJON SNARE**

**SIZE** 7 1/2"

**MATERIAL** Siam Oak (*Hevea brasiliensis* Muell.-Arg.)

**FEATURES** Internal Snare Wires  
Standard 3/8" rod mounting bracket  
L-shaped rod with knurled surface

**INCLUDES**

**COLOUR** **BK:** Black

**4 SILICONE PROTECTION COVER**

**SIZE** 7 1/2"

**MATERIAL** Silicone

**FEATURES** Shields your snare cajon from stick marks or scratches; Removable at any time

# CAJON ADD-ONS

ADD NEW SOUNDS  
TO YOUR CAJON



1



WC1-M

2

STAINLESS STEEL JINGLES



WJC1-M

3

STAINLESS STEEL JINGLES



JT-S-BK

4

EXTRA POCKET FOR  
SMALL PERCUSSION



CAJ-BLK

5

INTERNAL SNARE EFFECT



WSS1BK

6

DESIGNED TO HOLD OUR  
CAJON ADD-ONS CLOSE  
TO THE PLAYING SURFACE



Medium  
CSM-M

Large  
CSM-L

## 1 CAJON CASTANET

**SIZE** M: Medium  
**MATERIAL** Siam Oak (*Hevea brasiliensis* Muell.-Arg.)  
**FEATURES** Spring-opened; Hook and loop fastener goes on any surface  
**COLOUR** Black  
**FINISH** Matte

## 2 CAJON JINGLE CASTANET

**SIZE** M: Medium  
**MATERIAL** Siam Oak (*Hevea brasiliensis* Muell.-Arg.)  
**FEATURES** Spring-opened; Hook and loop fastener goes on any surface; Stainless steel jingles  
**COLOUR** Black  
**FINISH** Matte

## 3 JINGLE TAP

**SIZE** Medium  
**MATERIAL** Siam Oak (*Hevea brasiliensis* Muell.-Arg.)  
**FEATURES** Stainless steel jingles; Hook and loop fastener goes on any surface  
**COLOUR** BK: Black

## 4 CAJON BLANKET

**MATERIAL** Heavy-duty nylon  
**FEATURES** Fits on any cajon; Hook and loop fastener to mount additional add-ons  
**COLOUR** Black

## 5 WOOD SIDE SNARE

**MATERIAL** Siam Oak (*Hevea brasiliensis* Muell.-Arg.)  
**FEATURES** Internal snare effect; Hook and loop fastener attaches to Cajon body; Ergonomic shape; Unobtrusive low profile  
**COLOUR** BK: Black  
**FINISH** Matte

## 6 CAJON SIDE MOUNTS

**SIZES** M: Medium; L: Large  
**MATERIAL** Siam Oak (*Hevea brasiliensis* Muell.-Arg.)  
**FEATURES** Easy handling; Hook and loop fastener goes on any surface; Offers better cajon accessory placement  
**COLOUR** Black

## 7 KNEE PAD JINGLE / SNARE TAP

**MATERIAL** Siam Oak (*Hevea brasiliensis* Muell.-Arg.)  
**FEATURES** Strap with hook and loop fastener to mount on your leg  
**KP-JT-BK:** Stainless steel jingles  
**KP-ST-BK:** Snare effect  
**COLOUR** BK: Black



**8 MOTION SHAKERS**

**MATERIAL** Plastic  
**FEATURES** Comfortable to wear on your fingers  
**MS-BK:** Cutting shaker sound  
**MS-GR:** Crisp sound with more volume  
**COLOURS** **BK:** Black  
**GR:** Grey

**9 CAJON RING CASTANETS**

**SIZE** Large  
**MATERIALS** **CRC1BK:** Siam Oak (*Hevea brasiliensis* Muell.-Arg.)  
**PCRC1BK:** Plastic  
**COLOUR** **BK:** Black

**10 FINGER JINGLES**

**MATERIALS** Siam Oak (*Hevea brasiliensis* Muell.-Arg.)  
**FJS1A:** Aluminum jingles  
**FJS1S:** Stainless steel jingles

**11 CAJON SPINNER**

**SIZE** 13 3/4" W x 1 1/2" H x 13 3/4" D  
**MATERIAL** Baltic Birch (*Betula pendula*)  
**FEATURES** Durable turntable; Easy rotatable; Fits any common cajon  
**COLOUR** Black  
**FINISH** Matte

**12 SYNTHETIC LEATHER CAJON SEATS**

**MATERIAL** Sleek faux leather  
**FEATURES** Sleek faux leather cajon seat lets you play in comfort and style; The cushion provides lower body support for long sets on a cajon; Fits all common cajons  
**FINISHES** **GR:** Grey  
**VBR:** Vintage Brown  
**VR:** Vintage Red

**13 DELUXE CAJON SEAT**

**SIZE** 9 3/4" x 9 1/2"  
**MATERIALS** Inner material foam  
 Outer material leatherette  
**FEATURES** Thick padding with black leather finish; Embroidered with sleek red stitching and topped with a stamped MEINL logo; Elegant design and ultra-comfortable feel

**14 CAJON PAD**

**SIZE** 10" x 10"  
**MATERIAL** Soft foam

**15 CAJON PERC PACK**

**CONTAINS** Cajon Pad; Compact Foot Tambourine; Motion Shaker; Cajon Castanet, large; Luis Conte Live Shaker

# FOOT PERCUSSION

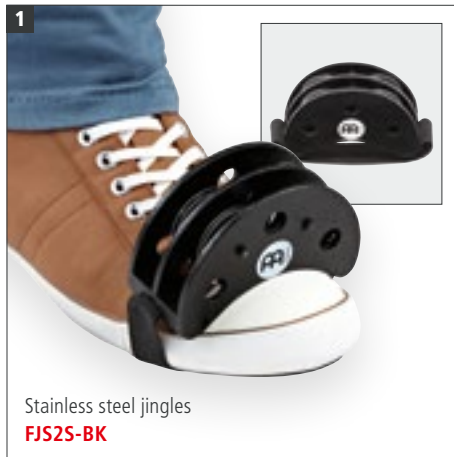

Stainless steel jingles  
**FJS2S-BK**



Stainless steel jingles  
**CFJS2S-BK**



Stainless steel jingles  
**CFT5-BK**



Black  
**FS-BK**



Black  
**CFC-BK**



**FR1NT**



**HTA**



**PHTA**



**HSH**

## 1 FOOT TAMBOURINE

**MATERIAL** Siam Oak (*Hevea brasiliensis* Muell.-Arg.)  
**FEATURES** Hassle-free mounting; Stainless steel jingles  
**COLOUR** **BK**: Black

## 2 COMPACT FOOT TAMBOURINE

**MATERIAL** Plastic  
**FEATURE** Attaches quickly and easily to foot via elastic strap  
**COLOUR** **BK**: Black

## 3 CAJON FOOT TAMBOURINE

**MATERIAL** Siam Oak (*Hevea brasiliensis* Muell.-Arg.)  
**FEATURES** 5 pairs of stainless steel jingles; Easily mountable  
**COLOUR** **BK**: Black

## 4 FOOT SHAKER

**MATERIAL** Plastic

**FEATURES** Easy mountable; Shaker mounted at a special angle for precise control  
**COLOUR** **BK**: Black

## 5 CAJON FOOT CASTANET

**MATERIALS** Siam Oak (*Hevea brasiliensis* Muell.-Arg.); Plastic  
**FEATURES** Traditional castanet sound; Easily mountable; Pair of plastic castanets  
**COLOUR** **BK**: Black

## 6 FOOT RATTLE

**MATERIAL** Siam Oak (*Hevea brasiliensis* Muell.-Arg.)  
**FEATURE** Hook and loop fastener  
**COLOUR** **NT**: Natural

## 7 HEEL TAMBOURINE

**MATERIALS** Siam Oak (*Hevea brasiliensis* Muell.-Arg.); Plastic; Stainless steel

**FEATURES** Stainless steel jingles for a bright full sound; Shoehorn design fits comfortably against your heel; Great accessory for hands free playing  
**COLOUR** Black

## 8 PROFESSIONAL HEEL TAMBOURINE

**MATERIALS** Siam Oak (*Hevea brasiliensis* Muell.-Arg.); Plastic; Stainless steel  
**FEATURES** Stainless steel jingles for a bright, full sound; Adjustable mounting system fits perfectly against your heel; Great accessory for hands-free playing

## 9 HEEL SHAKER

**MATERIAL** Plastic  
**FEATURES** Great accessory for hands-free playing; Shoehorn design fits comfortably against your heel  
**COLOUR** Black

# BASSBOX, SNAREBOX & FOOT CABASA



FOOT PERCUSSION

**1** ALUMINUM RAIL TO MOUNT ANY COMMON FOOT PEDAL



L-SHAPED SOFT FOAM BEATER INCLUDED

Baltic Birch  
**BASSBOX**

**2** TWO INTERNAL SNARE WIRES



L-SHAPED FELT BEATER INCLUDED

Baltic Birch  
**SNAREBOX**

**3**



Soft foam  
**BBB2**

**4**



Felt  
**SBB1**

**5** ADJUSTABLE BRASS JINGLES



Brass jingles  
**BBB1**

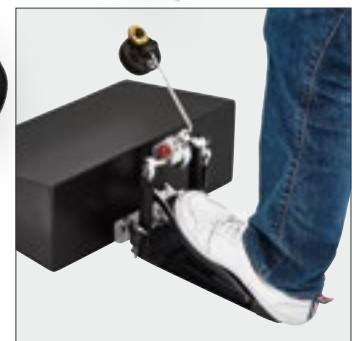

**6** PERFECT FOR THE MEINL BASSBOX AND SNAREBOX



**TMBP**

**7**



Additional springs with more tension  
**SPARE-20**

**FCA5-L**

## 1 BASSBOX

**SIZE** 17 1/2" W x 6 3/4" H x 11 3/4" D  
**MATERIAL** Resonating body: Baltic Birch (*Betula pendula*)  
**FEATURES** Immense bass sound; Perfect for guitarists and singers; Forward projection sound port; Playable with our BassBox/SnareBox Pedal or any common foot pedal  
**INCLUDES** L-shaped soft foam beater  
**COLOUR** Black  
**FINISH** Matte

## 2 SNAREBOX

**SIZE** 7 1/2" W x 7 1/2" H x 13" D  
**MATERIAL** Baltic Birch (*Betula pendula*)  
**FEATURES** Dual internal fixed snare wires; Perfect for guitarists and singers; Forward projection sound port; Playable with our

SnareBox/SnareBox Pedal or any other common foot pedal; Aluminum rail to mount any common foot pedal

**INCLUDES** L-shaped felt beater  
**COLOUR** Black  
**FINISH** Matte

## 3 BASSBOX BEATER

**MATERIAL** Soft foam rubber  
**FEATURES** Designed for the MEINL BassBox; L-shape for flush contact; Punchy response

## 4 SNAREBOX BEATER

**MATERIAL** Felt  
**FEATURES** Designed for the MEINL SnareBox; L-shape for flush contact; Crisp snare response

## 5 JINGLE CONTACT BASSBOX/SNAREBOX BEATER

**MATERIALS** Soft foam rubber; Brass jingles

**FEATURES** Soft L-shaped foam rubber beater with adjustable brass jingles; Easily turn the jingles on or off as desired throughout your set; Fits the MEINL BassBox/SnareBox

## 6 BASSBOX/SNAREBOX PEDAL

**MATERIAL** Steel  
**FEATURES** Adjustable spring tension to dial in your comfort zone; Perfect for the MEINL BassBox and SnareBox; Equipped to hold the MEINL L-shaped Beaters; Chain drive

## 7 FOOT CABASA (PATENTED)

**SIZE** Large  
**MATERIALS** Steel chain and stainless steel cylinder; Wooden body; Black powder coated pedal  
**FEATURES** Optional single or double-stroke setting; 5 sound ports on each side for more volume (CN, DE, US patent)  
**INCLUDES** Drum key; Foot pedal

# JR. & ROPE TUNED TRAVEL SERIES DJEMBES

1



Black, 7"  
JRD-BK



Blue, 7"  
JRD-B



Green, 7"  
JRD-G



Yellow, 7"  
JRD-Y



Orange, 7"  
JRD-O



Red, 7"  
JRD-R



Silver, 7"  
JRD-S



Twisted Amber, 7"  
JRD-TA



Pharaoh's Script, 7"  
JRD-PS



Kenyan Quilt, 7"  
JRD-KQ



2

DAY OF THE DEAD

12"  
PADJ7-L-F

10"  
PADJ7-M-F

NEW

SYNTHETIC HEAD

3



12"  
PADJ4-L-G

10"  
PADJ4-M-G

BLACK COLOURED HAND SELECTED GOATSKIN HEAD



KANGA SARONG

12"  
PADJ6-L-F

10"  
PADJ6-M-F

SYNTHETIC HEAD



SIMBRA

12"  
PADJ5-L-F

10"  
PADJ5-M-F

SYNTHETIC HEAD

## 1 JR. DJEMBES

**SIZE** 7" diameter, 12 1/2" tall  
**ROPE** 14 runners  
**MATERIALS** Synthetic shell; Synthetic head  
**FEATURES** Grab-and-go for any occasion, indoors or outside; Compact size and lightweight shell; Pre-stretched ropes; Produces sharp slaps and deep bass tones; 100% synthetic head and shell are perfect for outdoor playing  
**COLOURS** **B:** Blue  
**BK:** Black  
**G:** Green  
**O:** Orange  
**R:** Red  
**S:** Silver  
**Y:** Yellow  
**FINISHES** **KQ:** Kenyan Quilt  
**PS:** Pharaoh's Script  
**TA:** Twisted Amber

## 2 ROPE TUNED TRAVEL SERIES DJEMBES, SYNTHETIC HEAD (PATENTED)

**SIZES** **M:** 10" diameter, 20" tall  
**L:** 12" diameter, 24" tall  
**HTP ROPES** **M:** 4 mm thickness, 25 runners  
**L:** 4 mm thickness, 30 runners  
**MATERIALS** Synthetic shell; Synthetic head  
**FEATURES** 100% synthetic heads and shells are perfect for outdoor playing; Ultra light weight makes them easy to carry; Pre-stretched HTP nylon ropes; Produces sharp slaps and deep bass tones; Non-slip rubber bottom to protect the drum from scratches  
**FINISHES** **PADJ5:** Simbra  
**PADJ6:** Kanga Sarong  
**PADJ7:** Day of the Dead

## 3 ROPE TUNED TRAVEL SERIES DJEMBES, GOATSKIN HEAD (PATENTED)

**SIZES** **M:** 10" diameter, 20" tall  
**L:** 12" diameter, 24" tall  
**HTP ROPES** **M:** 4 mm thickness, 25 runners  
**L:** 4 mm thickness, 30 runners  
**MATERIALS** Synthetic shell; Black coloured hand selected goatskin head  
**FEATURES** Goatskin heads give you authentic sound and feel; Synthetic shells are perfect for outdoor playing; Ultra light weight makes them easy to carry; Pre-stretched HTP nylon ropes; Produces sharp slaps and deep bass tones; Non-slip rubber bottom to protect the drum from scratches  
**FINISH** **PADJ4:** Phantom Black





PHARAOH'S SCRIPT

KENYAN QUILT

14" PADJ1-XL-F    12" PADJ1-L-F    10" PADJ1-M-F    8" PADJ1-S-F    14" PADJ2-XL-F    12" PADJ2-L-F    10" PADJ2-M-F    8" PADJ2-S-F



PHARAOH'S SCRIPT

KENYAN QUILT

14" PADJ1-XL-G    12" PADJ1-L-G    10" PADJ1-M-G    8" PADJ1-S-G    14" PADJ2-XL-G    12" PADJ2-L-G    10" PADJ2-M-G    8" PADJ2-S-G

**4 ROPE TUNED TRAVEL SERIES DJEMBES, SYNTHETIC HEAD (PATENTED)**

- SIZES**    **S:** 8" diameter, 16" tall  
**M:** 10" diameter, 20" tall  
**L:** 12" diameter, 24" tall  
**XL:** 14" diameter, 26" tall
- HTP ROPES**    **S:** 4 mm thickness, 20 runners  
**M:** 4 mm thickness, 25 runners  
**L:** 4 mm thickness, 30 runners  
**XL:** 5 mm thickness, 35 runners

**MATERIALS** Synthetic shell; Synthetic head

**FEATURES** 100% synthetic heads and shells are perfect for outdoor playing; Ultra light weight makes them easy to carry; Pre-stretched HTP nylon ropes; Produces sharp slaps and deep bass tones; Non-slip rubber bottom to protect the drum from scratches

**FINISHES**    **PADJ1:** Pharaoh's Script  
**PADJ2:** Kenyan Quilt

**5 ROPE TUNED TRAVEL SERIES DJEMBES, GOATSKIN HEAD (PATENTED)**

- SIZES**    **S:** 8" diameter, 16" tall  
**M:** 10" diameter, 20" tall  
**L:** 12" diameter, 24" tall  
**XL:** 14" diameter, 26" tall
- HTP ROPES**    **S:** 4 mm thickness, 20 runners  
**M:** 4 mm thickness, 25 runners  
**L:** 4 mm thickness, 30 runners  
**XL:** 5 mm thickness, 35 runners

**MATERIALS** Synthetic shell; Hand selected goatskin head

**FEATURES** Goatskin heads give you authentic sound and feel; Synthetic shells are perfect for outdoor playing; Ultra light weight makes them easy to carry; Pre-stretched HTP nylon ropes; Produces sharp slaps and deep bass tones; Non-slip rubber bottom to protect the drum from scratches

**FINISHES**    **PADJ1:** Pharaoh's Script  
**PADJ2:** Kenyan Quilt

# MECHANICAL TUNED TRAVEL SERIES DJEMBES

**1**

**SYNTHETIC HEAD**



**SYNTHETIC HEAD**



**PHARAOH'S SCRIPT**



14"  
**PMDJ1-XL-F**
12"  
**PMDJ1-L-F**
10"  
**PMDJ1-M-F**
8"  
**PMDJ1-S-F**

**KENYAN QUILT**



14"  
**PMDJ2-XL-F**
12"  
**PMDJ2-L-F**
10"  
**PMDJ2-M-F**
8"  
**PMDJ2-S-F**

**2**

**HAND SELECTED GOATSKIN HEAD**



**HAND SELECTED GOATSKIN HEAD**



**PHARAOH'S SCRIPT**



14"  
**PMDJ1-XL-G**
12"  
**PMDJ1-L-G**
10"  
**PMDJ1-M-G**
8"  
**PMDJ1-S-G**

**KENYAN QUILT**



14"  
**PMDJ2-XL-G**
12"  
**PMDJ2-L-G**
10"  
**PMDJ2-M-G**
8"  
**PMDJ2-S-G**

**1 MECHANICAL TUNED TRAVEL SERIES DJEMBES, SYNTHETIC HEAD (PATENTED)**

- SIZES** **S:** 8" diameter, 16" tall  
**M:** 10" diameter, 20" tall  
**L:** 12" diameter, 24" tall  
**XL:** 14" diameter, 26" tall
- MATERIALS** Synthetic shell  
Synthetic head
- FEATURES** 100% synthetic heads and shells are perfect for outdoor playing  
Ultra light weight makes them easy to carry  
Quick and easy mechanical tuning system  
Produces sharp slaps and deep bass tones  
Non-slip rubber bottom to protect the drum from scratches
- FINISHES** **PMDJ1:** Pharaoh's Script  
**PMDJ2:** Kenyan Quilt

**2 MECHANICAL TUNED TRAVEL SERIES DJEMBES, GOATSKIN HEAD (PATENTED)**

- SIZES** **S:** 8" diameter, 16" tall  
**M:** 10" diameter, 20" tall  
**L:** 12" diameter, 24" tall  
**XL:** 14" diameter, 26" tall
- MATERIALS** Synthetic shell  
Hand selected goatskin head
- FEATURES** Goatskin heads give you authentic sound and feel  
Synthetic shells are perfect for outdoor playing  
Ultra light weight makes them easy to carry  
Quick and easy mechanical tuning system  
Produces sharp slaps and deep bass tones  
Non-slip rubber bottom to protect the drum from scratches
- FINISHES** **PMDJ1:** Pharaoh's Script  
**PMDJ2:** Kenyan Quilt

# ALPINE SERIES DJEMBES



**3** NEW

DAY OF THE DEAD



10"  
ADJ10-DA

SYNTHETIC HEAD



BARNWOOD



10"  
ADJ10-BW



SYNTHETIC DJEMBES

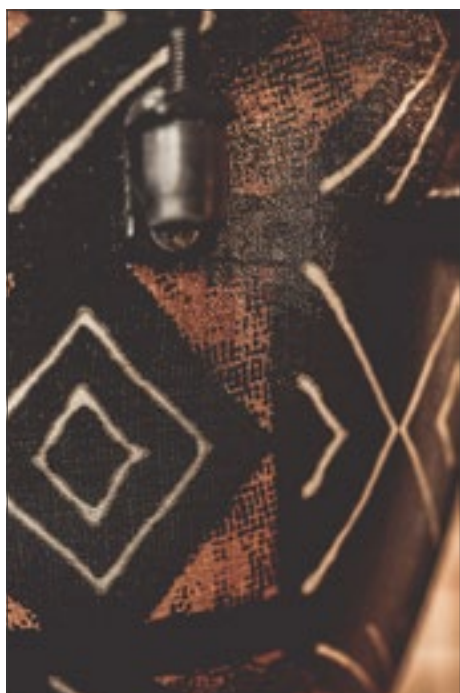

KANGA SARONG



10"  
ADJ10-KA

SIMBRA



10"  
ADJ10-SI

## 3 ALPINE SERIES DJEMBES

- SIZES 10" diameter, 20" tall
- MATERIALS Synthetic shell  
Synthetic head
- FEATURES Durable, synthetic head and shell  
Ultra light weight  
Mechanical tuning system  
Perfect for travel and outdoor performance
- FINISHES **BW:** Barnwood  
**DA:** Day of the Dead  
**KA:** Kanga Sarong  
**SI:** Simbra



# ROPE TUNED HEADLINER® SERIES WOOD DJEMBES



## ROPE TUNED HEADLINER® SERIES WOOD DJEMBES **1 2 3 4**

**SIZES**

- S:** 8" diameter, 15 3/4" tall
- M:** 10" diameter, 20" tall
- L:** 12" diameter, 24" tall
- XL:** 13" diameter, 25" tall

**PP ROPES**

- S:** 4 mm thickness, 16 runners
- M:** 4 mm thickness, 18 runners
- L:** 5 mm thickness, 20 runners
- XL:** 6 mm thickness, 24 runners

### **1 NILE SERIES**

**MATERIALS** Mahogany Wood (*Swietenia macrophylla*)  
Hand selected goatskin heads

**FEATURES** Carved from one solid piece of plantation grown Mahogany Wood  
Pre-stretched PP nylon ropes  
Hand carved shells

**COLOUR** Brown

### **2 BLACK RIVER SERIES**

**MATERIALS** Mahogany Wood (*Swietenia macrophylla*)  
Hand selected goatskin heads

**FEATURES** Carved from one solid piece of plantation grown Mahogany Wood  
Pre-stretched PP nylon ropes  
Hand carved shells

**COLOUR** Black

### **3 ARTIFACT SERIES**

**MATERIALS** Mahogany Wood (*Swietenia macrophylla*)  
Hand selected goatskin heads

**FEATURES** Carved from one solid piece of plantation grown Mahogany Wood  
Pre-stretched PP nylon ropes  
Hand carved shells

**COLOUR** Brown

### **4 CONGO SERIES**

**MATERIALS** Mahogany Wood (*Swietenia macrophylla*)  
Hand selected goatskin heads

**FEATURES** Carved from one solid piece of plantation grown Mahogany Wood  
Pre-stretched PP nylon ropes  
Hand carved shells  
Ornamental carving

**COLOUR** Dark Brown

# MINI & ROPE TUNED WOOD DJEMBES



**1**

Python Design, 4 1/2"  
**HDJ5-XXS**

Dark Serpent Design, 4 1/2"  
**HDJ6-XXS**

Gecko Design, 4 1/2"  
**HDJ7-XXS**

Flower Design, 4 1/2"  
**HDJ8-XXS**

**2**

BLACK COLOURED HAND SELECTED GOATSKIN HEADS

**FIRE RHYTHM SERIES**

13"  
**ADJ7-XL**

12"  
**ADJ7-L**

10"  
**ADJ7-M**

**EARTH RHYTHM SERIES**

13", bundle with bag  
**ADJ3-XL+BAG**

12", bundle with bag  
**ADJ3-L+BAG**

10", bundle with bag  
**ADJ3-M+BAG**

**WATER RHYTHM SERIES**

13", bundle with bag  
**ADJ2-XL+BAG**

12", bundle with bag  
**ADJ2-L+BAG**

10", bundle with bag  
**ADJ2-M+BAG**

WOOD DJEMBES

**1 AFRICAN STYLE MINI DJEMBES**

**SIZE** 4 1/2" (4 1/4" - 4 3/4") diameter, 8" tall

**PP ROPE** 3 mm thickness, 10 runners

**MATERIALS** Mahogany Wood (*Swietenia macrophylla*)  
Hand selected goatskin head

**FEATURES** Carved from one solid piece of plantation grown Mahogany Wood  
High quality PP nylon rope  
Hand painted shell

**FINISHES** **HDJ5:** Python Design  
**HDJ6:** Dark Serpent Design  
**HDJ7:** Gecko Design  
**HDJ8:** Flower Design

**2 ORIGINAL AFRICAN STYLE ROPE TUNED WOOD DJEMBES**

**SIZES** **M:** 10" (9 1/4" - 10 1/4") diameter, 20" tall  
**L:** 12" (10 3/4" - 12 1/4") diameter, 24" tall  
**XL:** 13" (12 3/4" - 13 3/4") diameter, 25" tall

**HTP ROPES** **M:** 4 mm thickness, 25 runners  
**L:** 4 mm thickness, 35 runners  
**XL:** 5 mm thickness, 35 runners

**MATERIALS** Mahogany Wood (*Swietenia macrophylla*)  
Hand selected goatskin heads

**FEATURES** Carved from one solid piece of plantation grown Mahogany Wood  
Pre-stretched HTP nylon ropes  
Hand carved shells  
Ornamental carving



**ADJ7**  
Black coloured hand selected goatskin heads  
Coloured rope wrapping

**INCLUDES** **ADJ2, ADJ3**  
Professional Djembe Bag made out of heavy-duty padded nylon

**COLOURS** **ADJ2:** Brown  
**ADJ3:** Brown/Black  
**ADJ7:** Black

# PROFESSIONAL, TONGO CARVED & ARTISAN DJEMBES



**1** SPECIAL "AFRICAN QUEEN" CARVING

12" **PROADJ4-L**

10" **PROADJ4-M**



**1** SPECIAL "VILLAGE" CARVING

12" **PROADJ2-L**

10" **PROADJ2-M**

**2** RUBBER PROTECTED BOTTOM

12" **DJTC1-L**

10" **DJTC1-M**

**3** COLOURED ROPE WRAPPING





12" **AE-DJTC1-L**

12" **AE-DJTC2-L**

**3** COLOURED ORNAMENTAL CARVING



**4** DELUXE CARVING



14" **PROADJ3-XXL**

**5**



**KES-01**



## 1 PROFESSIONAL AFRICAN STYLE DJEMBES

**SIZES** **M:** 10" (9 1/4" - 10 1/4") diameter, 20" tall  
**L:** 12" (10 3/4" - 12 1/4") diameter, 24" tall

**HTP ROPES** **M:** 4 mm thickness, 25 runners  
**L:** 4 mm thickness, 35 runners

**MATERIALS** Mahogany Wood (*Swietenia macrophylla*)  
 Hand selected goatskin heads

**FEATURES** Carved from one solid piece of plantation grown Mahogany Wood;  
 Pre-stretched HTP nylon ropes  
**PROADJ2:** "Village" carving  
**PROADJ4:** "African Queen" carving

**COLOUR** Brown

## 2 TONGO CARVED DJEMBES

**SIZES** **M:** 10" (9 1/4" - 10 1/4") diameter, 20" tall  
**L:** 12" (10 3/4" - 12 1/4") diameter, 24" tall

**HTP ROPES** **M:** 4 mm thickness, 30 runners  
**L:** 5 mm thickness, 30 runners

**MATERIALS** Mahogany Wood (*Swietenia macrophylla*)

**FEATURES** Hand selected cow heads  
 Carved from one solid piece of plantation grown Mahogany Wood;  
 Rubber protected bottom;  
 Carved out on the inside for better sound;  
 Pre-stretched HTP nylon ropes

**COLOUR** Brown

## 3 ARTISAN EDITION TONGO CARVED DJEMBES

**SIZES** 12" (10 3/4" - 12 1/4") diameter, 24" tall

**HTP ROPE** 5 mm thickness, 30 runners

**MATERIALS** Mahogany Wood (*Swietenia macrophylla*)  
 Hand selected goatskin heads

**FEATURES** Carved from one solid piece of plantation grown Mahogany Wood; Pre-stretched HTP nylon ropes; Hand carved shells  
**AE-DJTC1-L**  
 Coloured rope wrapping;  
 Ornamental carving

**AE-DJTC2-L**  
 Coloured ornamental carving  
 Brown

**COLOUR**

## 4 ARTISAN EDITION DJEMBE

**SIZE** 14" (13 3/4" - 15 1/4") diameter, 26" tall

**HTP ROPE** 5 mm thickness, 40 runners

**MATERIALS** Mahogany Wood (*Swietenia macrophylla*)  
 Hand selected goatskin head

**FEATURES** Carved from one solid piece of plantation grown Mahogany Wood; Pre-stretched HTP nylon rope; Deluxe carving

**COLOUR** Brown

## 5 KESSING

**SIZE** Medium

**MATERIAL** Aluminum

**FEATURES** Provides a dry rattling accompaniment to the drum; Slides securely into the webbing and is removable

# HEADLINER® & FLOATUNE SERIES WOOD DJEMBES



**1 ORIGINAL MEINL STYLE TUNING BRACKETS**

Vintage Wine Barrel, 12 1/2"  
**HDJ500VWB-M**

Natural, 12 1/2"  
**HDJ500NT**

**PROFESSIONAL DJEMBE STAND (SEE PAGE 88)**

**TMD**

**SAMBA BELT (SEE PAGE 62)**

**SB-R**

WOOD DJEMBES

**2 FLOATUNE TUNING SYSTEM**

Zebra Finished Ash, 12"  
**DJW3ZFA-M**

**3 FLOATUNE TUNING AVOIDS THE NEED TO DRILL THROUGH THE SHELL**

Gold Amber Sunburst, 12"  
**DJW3GAB-M**

Natural, 12"  
**DJW3NT**

**4 PROFESSIONAL SHOULDER STRAP**

**MDJS2**

**1 HEADLINER® SERIES WOOD DJEMBES**

**SIZE** 12 1/2" diameter, 25 1/4" tall  
**MATERIALS** Siam Oak (*Hevea brasiliensis* Muell.-Arg.)  
 Hand selected goatskin head  
**FEATURES** 8 mm strong tuning lugs  
 2.6 mm rounded rims  
 Original MEINL style tuning brackets  
 Black powder coated hardware  
 Sleek Hourglass shape for more comfort  
**INCLUDES** Tuning key  
**COLOURS** **NT:** Natural, high gloss  
**VWB-M:** Vintage Wine Barrel, matte

Easy tuning and comfortable change of heads  
 Rubber pads and lug placement offer perfect playing comfort  
 Floatune Tuning System  
 Chrome plated hardware  
**INCLUDES** Accessory pouch  
 L-shaped tuning key  
 Tune Up Oil  
**COLOUR** Zebra Finished Ash, matte

Rubber pads and lug placement offer perfect playing comfort  
 Floatune Tuning System  
 Chrome plated hardware  
**INCLUDES** Accessory pouch  
 L-shaped tuning key  
 Tune Up Oil  
**COLOURS** **GAB-M:** Gold Amber Sunburst, matte  
**NT:** Natural, high gloss

**2 FLOATUNE SERIES WOODCRAFT DJEMBE**

**SIZE** 12" diameter, 24 1/4" tall  
**MATERIALS** American White Ash (*Fraxinus americana* L.)  
 True Skin Goat Head  
**FEATURES** 8 mm strong tuning lugs  
 3 mm rounded SSR-Rims

**3 FLOATUNE SERIES WOOD DJEMBES**

**SIZE** 12" diameter, 24 1/4" tall  
**MATERIALS** Siam Oak (*Hevea brasiliensis* Muell.-Arg.)  
 True Skin Goat Head  
**FEATURES** 8 mm strong tuning lugs  
 3 mm rounded SSR-Rims  
 Easy tuning and comfortable change of heads

**4 PROFESSIONAL SHOULDER STRAP**

**MATERIAL** Heavy-duty nylon  
**FEATURES** Holds any djembe or other drums in perfect playing position  
 Length adjustable  
 Adjustable shoulder padding  
 Quick change hook  
**COLOUR** Black

# CONGA HEADS & MINI CONGAS

1



The REMO® Symmetry Conga Heads add more volume and resonance to your Conga. These are available for congas with this sign.



Black Calfskin Skyndeep® **RHEAD-11BK**    Black Calfskin Skyndeep® **RHEAD-1134BK**    Black Calfskin Skyndeep® **RHEAD-1212BK**



Black Calfskin Skyndeep® **RTHEAD-11BK**    Black Calfskin Skyndeep® **RTHEAD-1134BK**    Black Calfskin Skyndeep® **RTHEAD-1212BK**



Fiberskyn® **RHEAD-11NT**    Fiberskyn® **RHEAD-1134NT**    Fiberskyn® **RHEAD-1212NT**



Nuskyn® **RTHEAD-11NS**    Nuskyn® **RTHEAD-1134NS**    Nuskyn® **RTHEAD-1212NS**

2



Natural, 4 1/2" **MC100NT**

Vintage Wine Barrel, 4 1/2" **MC100VWB**

Wine Red, 4 1/2" **MC100WR**

3



**CONGA-SAVER8**    **CONGA-SAVER10**

4



COMES IN A SET OF 4

Set **MCR-BK**

5

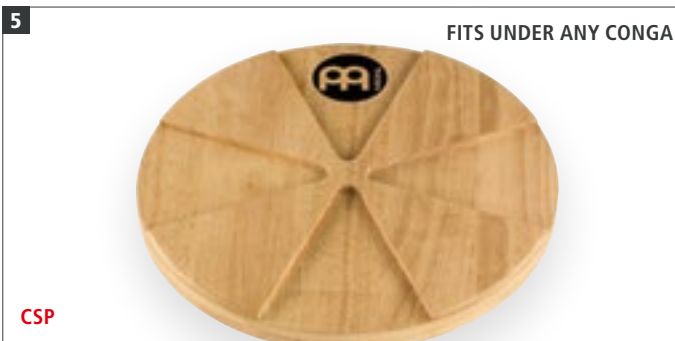

FITS UNDER ANY CONGA

**CSP**

## 1 REMO® SYMMETRY CONGA HEADS

**SIZES** **RHEAD-11:** 11" Quinto; SSR-Rim  
**RHEAD-1134:** 11 3/4" Conga; SSR-Rim  
**RHEAD-1212:** 12 1/2" Tumba; SSR-Rim  
**RTHEAD-11:** 11" Quinto; TTR-Rim  
**RTHEAD-1134:** 11 3/4" Conga; TTR-Rim  
**RTHEAD-1212:** 12 1/2" Tumba; TTR-Rim  
**FIT FOR** **RHEAD:** MCC, MEC, MP, FC, MSA, WKT, WCO, BWC  
**RTHEAD:** LC  
**FINISHES** **BK:** Black Calfskin Skyndeep®  
**NS:** Nuskyn®  
**NT:** Fiberskyn®

## 2 MINI CONGAS

**SIZE** 4 1/2" wide, 11" tall  
**MATERIALS** Siam Oak (*Hevea brasiliensis* Muell.-Arg.) Buffalo skin heads  
**FEATURES** Contains every feature of a regular MEINL conga, at 2/5 the size Tunable buffalo skin head with 4 chrome lugs and rounded rim Great for spontaneous jam sessions or drum circles  
**COLOURS** **NT:** Natural  
**VWB:** Vintage Wine Barrel  
**WR:** Wine Red

## 3 CONGA SAVERS

**SIZES** **CONGA-SAVER8:** for 8 mm tuning lugs  
**CONGA-SAVER10:** for 10 mm tuning lugs  
**FEATURES** Placed over the conga lugs to prevent them from damaging and scratching the shell Conga remains fully tunable

**PATENT** MEINL Conga Saver (TH, US patent)

## 4 CONGA RISERS

**MATERIAL** Sturdy rubber  
**FEATURES** Raise your drums off the floor to allow maximum sound projection Provide a stable base on any surface Come in a set of four Flexible construction  
**COLOUR** **BK:** Black

## 5 CONGA SOUND PLATE

**SIZE** 13 1/4"  
**MATERIAL** Siam Oak (*Hevea brasiliensis* Muell.-Arg.)  
**FEATURE** Provides a hard sound reflective surface under your conga



# WOODCRAFT SERIES CONGAS



1



VINTAGE BLACK

VINTAGE BROWN



11"  
**WCO11VBK-M**

11 3/4"  
**WCO1134VBK-M**

12 1/2"  
**WCO1212VBK-M**

11"  
**WCO11VBR-M**

11 3/4"  
**WCO1134VBR-M**

12 1/2"  
**WCO1212VBR-M**

VINTAGE RED

EUROPEAN BIRCH



11"  
**WCO11VR-M**

11 3/4"  
**WCO1134VR-M**

12 1/2"  
**WCO1212VR-M**

11"  
**BWC11**

11 3/4"  
**BWC1134**

12 1/2"  
**BWC1212**

2



## 1 WOODCRAFT SERIES WCO CONGAS

**SIZES** **WCO11:** 11" Quinto, 30" tall  
**WCO1134:** 11 3/4" Conga, 30" tall  
**WCO1212:** 12 1/2" Tumba, 30" tall

**MATERIALS** Three ply American White Ash  
(*Fraxinus americana* L.)

**FEATURES** True Skin Buffalo Heads  
10 mm strong tuning lugs  
4 mm rounded SSR-Rims  
Chrome plated hardware

**INCLUDES** MEINL Conga Saver (TH, US patent)  
MEINL Conga Handle  
MEINL Soundpads  
Accessory pouch  
L-shaped tuning key  
Tune Up Oil

**COLOURS** **VBK-M:** Vintage Black  
**VBR-M:** Vintage Brown  
**VR-M:** Vintage Red

**FINISH** Matte

## 2 WOODCRAFT SERIES BWC CONGAS

**SIZES** **BWC11:** 11" Quinto, 30" tall  
**BWC1134:** 11 3/4" Conga, 30" tall  
**BWC1212:** 12 1/2" Tumba, 30" tall

**MATERIALS** European Birch (*Betula pendula*)  
Hand selected Mule heads

**FEATURES** Natural finish European Birch shells  
Focused sounds without obtrusive overtones  
4 mm rounded SSR-Rims  
Chrome plated hardware

**INCLUDES** MEINL Conga Saver (TH, US patent)  
MEINL Conga Handle  
MEINL Soundpads  
Accessory pouch  
L-shaped tuning key  
Tune Up Oil

**COLOUR** Natural  
**FINISH** High gloss



**NENÉ VÁSQUEZ, GERMANY**

CONGAS

# WOODCRAFT TRADITIONAL, FLOATUNE SERIES CONGAS

1

ZEBRA FINISHED ASH



11"  
WC11ZFA-M

11 3/4"  
WC1134ZFA-M

12 1/2"  
WC1212ZFA-M



DAVID MARCANO, PUERTO RICO

2

NATURAL



10"  
FL10NT

11"  
FL11NT

12"  
FL12NT

13"  
FL13NT

THE FLOATUNE TUNING SYSTEM  
ALLOWS THE SHELL TO  
VIBRATE FREELY



## 1 WOODCRAFT TRADITIONAL SERIES CONGAS

**SIZES** WC11: 11" Quinto, 30" tall  
WC1134: 11 3/4" Conga, 30" tall  
WC1212: 12 1/2" Tumba, 30" tall

**MATERIALS** Three ply American White Ash (*Fraxinus americana* L.)  
True Skin Buffalo Heads

**FEATURES** 10 mm strong tuning lugs  
5 mm traditional TTR-Rims  
Chrome plated hardware

**INCLUDES** MEINL Conga Saver (TH, US patent)  
MEINL Conga Handle  
MEINL Soundpads  
Accessory pouch  
L-shaped tuning key  
Tune Up Oil

**COLOUR** Zebra Finished Ash  
**FINISH** Matte

## 2 FLOATUNE SERIES CONGAS

**SIZES** FL10: 10" Nino, 30" tall  
FL11: 11" Quinto, 30" tall  
FL12: 12" Conga, 30" tall  
FL13: 13" Tumba, 30" tall

**MATERIALS** Two ply Siam Oak (*Hevea brasiliensis* Muell.-Arg.)  
True Skin Buffalo Heads

**FEATURES** Floatune Tuning System  
10 mm strong tuning lugs  
4 mm rounded SSR-Rims  
Chrome plated hardware

**INCLUDES** MEINL Conga Saver (TH, US patent)  
MEINL Conga Handle  
MEINL Soundpads  
Accessory pouch  
L-shaped tuning key  
Tune Up Oil

**COLOUR** Natural  
**FINISH** High gloss

# PROFESSIONAL & FIBERCRAFT SERIES CONGAS



**1**

REMO HEADS AVAILABLE

11" **MP11NT**

11 3/4" **MP1134NT**

12 1/2" **MP1212NT**

NATURAL

BROWN BURL

11" **MP11BB**

11 3/4" **MP1134BB**

12 1/2" **MP1212BB**

**2**

REMO HEADS AVAILABLE

TRUE SKIN BUFFALO HEADS

11" **FC11BK**

11 3/4" **FC1134BK**

12 1/2" **FC1212BK**

REMO® BLACK CALFSKIN SKYNDDEEP® HEADS

11" **FCR11BK**

11 3/4" **FCR1134BK**

12 1/2" **FCR1212BK**

## 1 PROFESSIONAL SERIES CONGAS

- SIZES** **MP11:** 11" Quinto, 30" tall  
**MP1134:** 11 3/4" Conga, 30" tall  
**MP1212:** 12 1/2" Tumba, 30" tall
- MATERIALS** Two ply Siam Oak  
*(Hevea brasiliensis Muell.-Arg.)*  
 True Skin Buffalo Heads
- FEATURES** 10 mm strong tuning lugs  
 4 mm rounded SSR-Rims  
 Chrome plated hardware
- INCLUDES** MEINL Conga Saver (TH, US patent)  
 MEINL Conga Handle  
 MEINL Soundpads  
 Accessory pouch  
 L-shaped tuning key  
 Tune Up Oil
- COLOURS** **BB:** Brown Burl  
**NT:** Natural
- FINISH** High gloss

## 2 FIBERCRAFT SERIES CONGAS

- SIZES** **FC(R)11:** 11" Quinto, 30" tall  
**FC(R)1134:** 11 3/4" Conga, 30" tall  
**FC(R)1212:** 12 1/2" Tumba, 30" tall
- MATERIALS** Premium fiberglass  
**FC:** True Skin Buffalo Heads  
**FCR:** REMO® Black Calfskin Skynddeep® Heads (For more volume and resonance)
- FEATURES** 10 mm strong tuning lugs  
 4 mm rounded SSR-Rims  
 Chrome plated hardware
- INCLUDES** MEINL Conga Saver (TH, US patent)  
 MEINL Conga Handle  
 MEINL Soundpads  
 Accessory pouch  
 L-shaped tuning key  
 Tune Up Oil
- COLOUR** **BK:** Black

## REMO® SYMMETRY CONGA HEADS (SEE PAGE 28)



The REMO® Symmetry Conga Heads add more volume and resonance to your Conga. These are available for congas with this sign.



# ARTIST SERIES CONGAS

**1**

REMO HEADS AVAILABLE

REMO® NUSKYN® HEADS

LC11NT-M      LC1134NT-M      LC1212NT-M      LCR11NT-M      LCR1134NT-M      LCR1212NT-M

**2**

REMO HEADS AVAILABLE

MSA11AWA      MSA1134AWA      MSA1212AWA

## 1 ARTIST SERIES CONGAS LUIS CONTE

**SIZES** **LC(R)11:** 11" Quinto, 30" tall  
**LC(R)1134:** 11 3/4" Conga, 30" tall  
**LC(R)1212:** 12 1/2" Tumba, 30" tall

**MATERIALS** Two ply Siam Oak  
 (Hevea brasiliensis Muell.-Arg.)  
**LC:** True Skin Buffalo Heads  
**LCR:** REMO® Nuskyn® Heads  
 (For more volume and resonance)

**FEATURES** 8 mm strong tuning lugs  
 5 mm traditional TTR-Rims  
 Black powder coated hardware

**INCLUDES** MEINL Conga Saver (TH, US patent)  
 MEINL Soundpads  
 Accessory pouch  
 L-shaped tuning key  
 Tune Up Oil

**COLOUR** **NT:** Natural

**FINISH** Matte

## 2 ARTIST SERIES CONGAS

**RAMON "MONGO" SANTAMARIA**

**SIZES** **MSA11:** 11" Quinto, 30" tall  
**MSA1134:** 11 3/4" Conga, 30" tall  
**MSA1212:** 12 1/2" Tumba, 30" tall

**MATERIALS** Two ply American White Ash  
 (Fraxinus americana L.)  
 True Skin Buffalo Heads

**FEATURES** 10 mm strong tuning lugs  
 4 mm rounded SSR-Rims  
 Gold tone hardware

**INCLUDES** MEINL Conga Saver (TH, US patent)  
 MEINL Soundpads  
 Accessory pouch  
 L-shaped tuning key  
 Tune Up Oil

**COLOUR** **AWA:** American White Ash

**FINISH** High gloss



3

REMO HEADS AVAILABLE

HAND SELECTED MULESKIN HEADS



11" WKTR11NT

11 3/4" WKTR1134NT

12 1/2" WKTR1212NT

CONGAS

REMO® BLACK CALFSKIN SKYNDEEP® HEADS



INCLUDES CONGA HANDLE

*Kehiro Thompson*

11" WKTR11NT

11 3/4" WKTR1134NT

12 1/2" WKTR1212NT

3 ARTIST SERIES CONGAS

WILLIAM "KACHIRO" THOMPSON

SIZES **WKTR(R)11:** 11" Quinto, 30" tall  
**WKTR(R)1134:** 11 3/4" Conga, 30" tall  
**WKTR(R)1212:** 12 1/2" Tumba, 30" tall

MATERIALS Three ply Siam Oak  
(*Hevea brasiliensis* Muell.-Arg.)  
**WKT:** Hand selected muleskin heads  
**WKTR:** REMO® Black Calfskin Skyndeep® Heads (For more volume and resonance)

FEATURES 10 mm strong tuning lugs  
4 mm rounded SSR-Rims  
Gold tone hardware

INCLUDES MEINL Conga Saver (TH, US patent)  
MEINL Conga Handle  
MEINL Soundpads  
Accessory pouch

L-shaped tuning key; Tune Up Oil

COLOUR **NT:** Natural  
FINISH High gloss

REMO® SYMMETRY CONGA HEADS  
(SEE PAGE 28)



The REMO® Symmetry Conga Heads add more volume and resonance to your Conga. These are available for congas with this sign.



# MARATHON® EXCLUSIVE & DESIGNER SERIES CONGAS



11"  
MEC11NT-CH

11 3/4"  
MEC1134NT-CH

12 1/2"  
MEC1212NT-CH

11"  
MECR11NT-CH

11 3/4"  
MECR1134NT-CH

12 1/2"  
MECR1212NT-CH



11"  
MEC11NT-G

11 3/4"  
MEC1134NT-G

12 1/2"  
MEC1212NT-G

11"  
MCC11LB

11 3/4"  
MCC1134LB

12 1/2"  
MCC1212LB

## 1 MARATHON® EXCLUSIVE SERIES CONGAS

**SIZES** **MEC(R)11:** 11" Quinto, 30" tall  
**MEC(R)1134:** 11 3/4" Conga, 30" tall  
**MEC(R)1212:** 12 1/2" Tumba, 30" tall

**MATERIALS** Two ply Siam Oak  
(*Hevea brasiliensis* Muell.-Arg.)

**MEC:** True Skin Buffalo Heads

**MECR:** REMO® Fiberskyn® Heads  
(For more volume and resonance)

**FEATURES** 8 mm strong tuning lugs  
2.6 mm rounded SSR-Rims

**CH:** Chrome plated hardware

**G:** Gold tone hardware

**INCLUDES** Steely II Conga Stand (patented)  
MEINL Conga Saver (TH, US patent)  
MEINL Conga Handle  
MEINL Sound Pads  
Accessory pouch  
L-shaped tuning key  
Tune Up Oil

**COLOUR** **NT:** Natural  
**FINISH** High gloss  
**PATENTS** Steely-II patents:  
L-shaped leg and metal spike attachment  
(DE, TH, US patent)  
U-shaped notch (US patent)  
Ergonomic arched rubber bracing  
(CN, DE, TH, US patent)  
Notches for quick height adjustability  
(DE patent)

## 2 MARATHON® DESIGNER SERIES CONGAS

**SIZES** **MCC11:** 11" Quinto, 30" tall  
**MCC1134:** 11 3/4" Conga, 30" tall  
**MCC1212:** 12 1/2" Tumba, 30" tall

**MATERIALS** Two ply Siam Oak  
(*Hevea brasiliensis* Muell.-Arg.)  
True Skin Buffalo Heads

**FEATURES** 8 mm strong tuning lugs  
2.6 mm rounded SSR-Rims  
Black powder coated hardware  
**INCLUDES** Steely II Conga Stand (patented)  
MEINL Conga Saver (TH, US patent)  
Accessory pouch  
L-shaped tuning key  
Tune Up Oil

**COLOUR** **LB:** Leopard Burl  
**FINISH** High gloss  
**PATENTS** Steely-II patents:  
L-shaped leg and metal spike attachment  
(DE, TH, US patent)  
U-shaped notch (US patent)  
Ergonomic arched rubber bracing  
(CN, DE, TH, US patent)  
Notches for quick height adjustability  
(DE patent)

# MARATHON® CLASSIC SERIES CONGAS



3

REMO HEADS AVAILABLE



NATURAL

11"  
MCC11NT

11 3/4"  
MCC1134NT

12 1/2"  
MCC1212NT

ERGONOMIC ARCHED RUBBER BRACING

U-SHAPED NOTCH

NOTCHES FOR QUICK HEIGHT ADJUSTABILITY

L-SHAPED LEG

METAL SPIKE ATTACHMENT

STEELY II CONGA STAND



CONGAS



SUPER NATURAL

11"  
MCC11SNT-M

11 3/4"  
MCC1134SNT-M

12 1/2"  
MCC1212SNT-M



COFFEE BURST

11"  
MCC11CB

11 3/4"  
MCC1134CB

12 1/2"  
MCC1212CB

## 3 MARATHON® CLASSIC SERIES CONGAS

**SIZES** **MCC11:** 11" Quinto, 30" tall  
**MCC1134:** 11 3/4" Conga, 30" tall  
**MCC1212:** 12 1/2" Tumba, 30" tall

**MATERIALS** Two ply Siam Oak  
(*Hevea brasiliensis* Muell.-Arg.)  
True Skin Buffalo Heads

**FEATURES** 8 mm strong tuning lugs  
2.6 mm rounded SSR-Rims  
Black powder coated hardware

**INCLUDES** Steely II Conga Stand (patented)  
MEINL Conga Saver (TH, US patent)  
Accessory pouch  
L-shaped tuning key  
Tune Up Oil

**COLOURS** **CB:** Coffee Burst, high gloss  
**NT:** Natural, high gloss  
**SNT-M:** Super Natural, matte

## PATENTS

Steely-II patents:  
L-shaped leg and metal spike attachment (DE, TH, US patent)  
U-shaped notch (US patent)  
Ergonomic arched rubber bracing (CN, DE, TH, US patent)  
Notches for quick height adjustability (DE patent)

## REMO® SYMMETRY CONGA HEADS (SEE PAGE 28)



The REMO® Symmetry Conga Heads add more volume and resonance to your Conga. These are available for congas with this sign.

Fiberskyn®

Nuskyn®

Black Calfskin  
Skyndee®



# HEADLINER® SERIES CONGAS

1



PHANTOM BLACK

ERGONOMIC ARCHED RUBBER BRACING

U-SHAPED NOTCH

L-SHAPED LEG

BASKET STAND



10"  
HC10PBK-M

11"  
HC11PBK-M

12"  
HC12PBK-M



VINTAGE WINE BARREL



SUPER NATURAL

10"  
HC10VWB-M

11"  
HC11VWB-M

12"  
HC12VWB-M

10"  
HC10SNT-M

11"  
HC11SNT-M

12"  
HC12SNT-M

## 1 HEADLINER® SERIES CONGAS

- SIZES**  
**HC10:** 10" Nino, 28" tall  
**HC11:** 11" Quinto, 28" tall  
**HC12:** 12" Conga, 28" tall
- MATERIALS**  
 Siam Oak (*Hevea brasiliensis* Muell.-Arg.)  
 Hand selected buffalo heads
- FEATURES**  
 8 mm strong tuning lugs  
 Original MEINL style tuning brackets  
 2 mm rounded rims  
 Black powder coated hardware
- INCLUDES**  
 Height adjustable basket stands (patented) with quick set up system  
 Tuning key
- COLOURS**  
**PBK-M:** Phantom Black  
**SNT-M:** Super Natural  
**VWB-M:** Vintage Wine Barrel
- FINISH**  
 Matte

### PATENTS

Basket stand patents:  
 Ergo arched rubber bracing (CN, DE, TH, US patent)  
 U-shaped notch (US patent)  
 L-shaped leg (DE patent)



KEITA OGAWA, USA



# HEADLINER® TRADITIONAL SERIES CONGAS



CUBANO RETRO

CONGAS



10"  
**HTC10WB-M**

11"  
**HTC11WB-M**

12"  
**HTC12WB-M**

## 2 HEADLINER® TRADITIONAL SERIES CONGAS

- SIZES** **HTC10:** 10" Nino, 28" tall  
**HTC11:** 11" Quinto, 28" tall  
**HTC12:** 12" Conga, 28" tall
- MATERIALS** Siam Oak (*Hevea brasiliensis* Muell.-Arg.)  
Hand selected buffalo heads
- FEATURES** 8 mm strong tuning lugs  
Original MEINL style tuning brackets  
5 mm traditional TTR-Rims  
Black powder coated hardware
- INCLUDES** Height adjustable basket stands  
(patented) with quick set up system  
Tuning key
- COLOUR** **WB-M:** Walnut Brown
- FINISH** Matte
- PATENTS** Basket stand patents:  
Ergo arched rubber bracing  
(CN, DE, TH, US patent)  
U-shaped notch (US patent)  
L-shaped leg (DE patent)

# HEADLINER® SERIES CONGA SETS

NATURAL



Set, 10" & 11"  
**HC555NT**



Set, 11" & 12"  
**HC512NT**



Set, 10" & 11"  
**HC888NT**



Set, 11" & 12"  
**HC812NT**

## HEADLINER® SERIES CONGA SETS

**SIZES** **HC555, HC888:**  
10" Nino & 11" Quinto, 28" tall  
**HC512, HC812:**  
11" Quinto & 12" Conga, 28" tall

**MATERIALS** Siam Oak (*Hevea brasiliensis* Muell.-Arg.)  
Hand selected buffalo heads

**FEATURES** 8 mm strong tuning lugs  
Original MEINL style tuning brackets  
2 mm rounded rims  
Black powder coated hardware

**INCLUDES** Tuning key  
**HC555, HC512:** Height adjustable  
basket stands (patented) with quick  
set up system  
**HC888, HC812:** Height adjustable  
double braced tripod stand

**COLOURS** **NT:** Natural  
**VSB:** Vintage Sunburst

**FINISH** High gloss

## PATENTS

Basket stand patents:  
Ergo arched rubber bracing  
(CN, DE, TH, US patent)  
U-shaped notch (US patent)  
L-shaped leg (DE patent)



VINTAGE SUNBURST

CONGAS



Set, 10" & 11"  
**HC555VSB**



Set, 11" & 12"  
**HC512VSB**



Set, 10" & 11"  
**HC888VSB**



Set, 11" & 12"  
**HC812VSB**



CARLOS MALDONADO, USA

THE BONGO MOUNT IS EASY MOUNTABLE ON OUR CONGA DOUBLE STANDS (SEE PAGE 86)



THBM

# BONGO HEADS & WOODCRAFT SERIES WOOD BONGOS

1



The REMO® R-Series Bongo Heads add more volume and resonance to your Bongo. These are available for bongos with this sign.



Fiberskyn®  
**RHEAD-7NT**



Fiberskyn®  
**RHEAD-812NT**



Nuskyn®  
**RHEAD-7NS**



Nuskyn®  
**RHEAD-812NS**



Black Calfskin Skyndeeep®  
**RHEAD-7BK**



Black Calfskin Skyndeeep®  
**RHEAD-812BK**



2



Vintage Black, 7" & 8 1/2"  
**WB400VBK-M**



Vintage Brown, 7" & 8 1/2"  
**WB400VBR-M**



Vintage Red, 7" & 8 1/2"  
**WB400VR-M**

3



European Birch, 7" & 8 1/2"  
**BWB400**

4

CHROME PLATED 5 MM TRADITIONAL TTR RIM



Antique Mahogany Burst, 7" & 9"  
**WB500AMB**



Zebra Finished Ash, 7" & 9"  
**WB500ZFA-M**

## 1 REMO® R-SERIES BONGO HEADS

**SIZES** **RHEAD-7:** 7" Macho  
**RHEAD-812:** 8 1/2" Hembra  
**FIT FOR** LC300, FFB400, FWB400, CS400, WB400, BWB400  
**FINISHES** **BK:** Black Calfskin Skyndeeep®  
**NS:** Nuskyn®  
**NT:** Fiberskyn®

## WOODCRAFT SERIES WOOD BONGOS

**2 3 4**  
**FEATURES** MEINL Free Ride Suspension System  
Chrome plated hardware  
Resonance Shaping Area  
**INCLUDES** Accessory pouch  
L-shaped tuning key  
Tune Up Oil

## 2 WOODCRAFT SERIES WB400 WOOD BONGOS

**SIZES** 7" Macho & 8 1/2" Hembra  
**MATERIALS** American White Ash (*Fraxinus americana* L.)  
True Skin Cow Heads  
**FEATURES** 8 mm strong tuning lugs  
3 mm rounded SSR-Rims  
**COLOURS** **VBK-M:** Vintage Black  
**VBR-M:** Vintage Brown  
**VR-M:** Vintage Red  
**FINISH** Matte

## 3 WOODCRAFT SERIES BWB400 WOOD BONGO

**SIZES** 7" Macho & 8 1/2" Hembra  
**MATERIALS** European Birch (*Betula pendula*)  
Hand selected calf heads  
**FEATURES** Natural finish European Birch shells  
8 mm strong tuning lugs  
3 mm rounded SSR-Rims  
**COLOUR** Natural

## 4 WOODCRAFT SERIES WB500 WOOD BONGOS

**SIZES** 7" Macho & 9" Hembra  
**MATERIALS** American White Ash (*Fraxinus americana* L.)  
True Skin Cow Heads  
**FEATURES** 8 mm strong tuning lugs  
5 mm traditional TTR-Rims  
**COLOURS** **AMB:** Antique Mahogany Burst, high gloss  
**ZFA-M:** Zebra Finished Ash, matte



MEINL'S RAPC (RADIAL PLY CONSTRUCTION) FEATURES 5 LAYERS THAT CREATE SUPER STRONG BUT LIGHTWEIGHT BONGO SHELLS WITH ENHANCED RESONANCE



1

RAPC TECHNOLOGY



Desert Burl, 6 3/4" & 8"  
**MB400DB-M**

2



American White Ash, 7" & 8 1/2"  
**CS400AWA-M**



Cherry, 6 3/4" & 8"  
**MB400CHE**



Ebony Black, 6 3/4" & 8"  
**MB400EBP**

3



Natural, 7" & 8 1/2"  
**FWB400NT**



Brown Burl, 7" & 8 1/2"  
**FWB400BB**



Cherry Red, 7" & 8 1/2"  
**FWB400CR**



Gold Amber Sunburst, 7" & 8 1/2"  
**FWB400GAB**

4



PREMIUM FIBERGLASS



Black, 7" & 8 1/2"  
**FFB400BK**

REMO® BLACK CALFSKIN SKYNDDEEP® HEADS



Black, 7" & 8 1/2"  
**FFBR400BK**

## 1 RAPC (RADIAL PLY CONSTRUCTION) BONGOS

- SIZES** 6 3/4" Macho & 8" Hembra
- MATERIALS** 5 layers of plywood; True Skin Cow Heads
- FEATURES** MEINL Free Ride Suspension System; Chrome plated hardware; RAPC Technology; 8 mm strong tuning lugs; 2 mm rounded SSR-Rims; Resonance Shaping Area
- INCLUDES** Accessory pouch; L-shaped tuning key; Tune Up Oil
- COLOURS** **CHE**: Cherry, high gloss  
**DB-M**: Desert Burl, matte  
**EBP**: Ebony Black, high gloss

## 2 COLLECTION SERIES CS400 WOOD BONGO

- SIZES** 7" Macho & 8 1/2" Hembra
- MATERIALS** American White Ash (*Fraxinus americana* L.) True Skin Cow Heads

- FEATURES** MEINL Free Ride Suspension System; Chrome plated hardware; 8 mm strong tuning lugs; 3 mm rounded SSR-Rims; Resonance Shaping Area
- INCLUDES** Accessory pouch; L-shaped tuning key; Tune Up Oil
- COLOUR** **AWA-M**: American White Ash, matte

## 3 PROFESSIONAL SERIES FWB400 WOOD BONGOS

- SIZES** 7" Macho & 8 1/2" Hembra
- MATERIALS** Siam Oak (*Hevea brasiliensis* Muell.-Arg.) True Skin Cow Heads
- FEATURES** MEINL Free Ride Suspension System; Chrome plated hardware; 8 mm strong tuning lugs; 3 mm rounded SSR-Rims; Resonance Shaping Area
- INCLUDES** Accessory pouch; L-shaped tuning key; Tune Up Oil

- COLOURS** **BB**: Brown Burl, high gloss  
**CR**: Cherry Red, high gloss  
**GAB**: Gold Amber Sunburst, high gloss  
**NT**: Natural, high gloss

## 4 FIBERCRAFT SERIES FIBERGLASS BONGOS

- SIZES** 7" Macho & 8 1/2" Hembra
- MATERIALS** Premium fiberglass  
**FFB400BK**: True Skin Cow Heads  
**FFBR400BK**: REMO® Black Calfskin Skynddeep® Heads (For more volume and resonance)
- FEATURES** MEINL Free Ride Suspension System; Chrome plated hardware; 8 mm strong tuning lugs; 3 mm rounded SSR-Rims; Resonance Shaping Area
- INCLUDES** Accessory pouch; L-shaped tuning key; Tune Up Oil
- COLOUR** **BK**: Black

# WOOD, ARTIST & MARATHON® SERIES BONGOS

**1** **TRADITIONAL TTR-RIM**

REMO HEADS AVAILABLE



Natural, 6 3/4" & 8"  
**LC300NT-M**

TRADITIONAL SOLID WOODBLOCK CONSTRUCTION

*LC300*

**2** **CHROME PLATED ROUNDED SSR RIM**



Natural, 6 3/4" & 8"  
**WB200NT-CH**

**GOLD TONE ROUNDED SSR RIM**



Natural, 6 3/4" & 8"  
**WB200NT-G**

**3** **CHROME PLATED ROUNDED SSR RIM**



Natural, 6 3/4" & 8"  
**FWB200NT**

**CHROME PLATED ROUNDED SSR RIM**



Super Natural, 6 3/4" & 8"  
**WB200SNT-M**

**4**



Leopard Burl, 6 3/4" & 8"  
**FWB190LB**



Amber Flame, 6 3/4" & 8"  
**FWB190AF**



Gold Amber Sunburst, 6 3/4" & 8"  
**FWB200GAB**

**5**



Natural, 6 3/4" & 8"  
**FWB190NT**



Super Natural, 6 3/4" & 8"  
**FWB190SNT-M**



Antique Tobacco Burst, 6 3/4" & 8"  
**FWB190ATB-M**

**1 ARTIST SERIES LC300 WOOD BONGO LUIS CONTE**  
**SIZES** 6 3/4" Macho & 8" Hembra  
**MATERIALS** Siam Oak (*Hevea brasiliensis* Muell.-Arg.) True Skin Cow Heads  
**FEATURES** Solid woodblock connection; Black powder coated hardware; 8 mm strong tuning lugs; 5 mm traditional TTR-Rims  
**INCLUDES** Accessory pouch; L-shaped tuning key; Tune Up Oil  
**COLOUR** **NT-M:** Natural, matte

**2 WB200 WOOD BONGOS**  
**SIZES** 6 3/4" Macho & 8" Hembra  
**MATERIALS** Siam Oak (*Hevea brasiliensis* Muell.-Arg.) Hand selected buffalo heads  
**FEATURES** Solid woodblock connection; 8 mm strong tuning lugs; 2 mm rounded SSR-Rim;  
**WB200NT-CH:** Chrome plated hardware

**WB200NT-G:** Gold tone hardware  
**WB200SNT-M:** Chrome plated hardware  
**INCLUDES** Accessory pouch; L-shaped tuning key; Tune Up Oil  
**COLOURS** **NT:** Natural, high gloss  
**SNT-M:** Super Natural, matte

**MARATHON® SERIES WOOD BONGOS**  
**3 4 5**  
**SIZES** 6 3/4" Macho & 8" Hembra  
**MATERIALS** Siam Oak (*Hevea brasiliensis* Muell.-Arg.) Hand selected buffalo heads  
**FEATURES** MEINL Free Ride Suspension System; 8 mm strong tuning lugs  
**INCLUDES** Accessory pouch; L-shaped tuning key; Tune Up Oil

**3 MARATHON® EXCLUSIVE SERIES FWB200 WOOD BONGOS**  
**FEATURES** Chrome plated hardware;

**COLOURS** 2 mm rounded SSR-Rims  
**GAB:** Gold Amber Sunburst, high gloss  
**NT:** Natural, high gloss

**4 MARATHON® DESIGNER SERIES FWB190 WOOD BONGOS**  
**FEATURES** Unique designs; Black powder coated hardware; 2.5 mm rounded SSR-Rims  
**COLOURS** **AF:** Amber Flame, high gloss  
**LB:** Leopard Burl, high gloss

**5 MARATHON® SERIES FWB190 WOOD BONGOS**  
**FEATURES** Black powder coated hardware; 2 mm rounded SSR-Rims  
**COLOURS** **ATB-M:** Antique Tobacco Burst, matte  
**NT:** Natural, high gloss  
**SNT-M:** Super Natural, matte

# HEADLINER®, JOURNEY & MINI WOOD BONGOS



BONGOS

**1**

Natural, 6 3/4" & 8"  
**HB100NT**

Vintage Sunburst, 6 3/4" & 8"  
**HB100VSB**

Wine Red Burst, 6 3/4" & 8"  
**HB100WRB**

**2**

TRADITIONAL TTR-RIM

Vintage Wine Barrel, 6 3/4" & 8"  
**HB100VWB-M**

Walnut Brown, 6 3/4" & 8"  
**HTB100WB-M**

PREMIUM FIBERGLASS

Black, 6 3/4" & 8"  
**HFB100BK**

**3**

STURDY ABS PLASTIC

Black, 6 1/2" & 7 1/2"  
**HB50BK**

**4**

BONGO & PERCUSSION PACK

Set, 4 pcs.  
**BPP-1**

**5**

MINI!

Super Natural, 3 1/2" & 4 1/4"  
**FWB100SNT-M**

**1 HEADLINER® SERIES HB100 / HTB100 WOOD BONGOS**

**SIZES** 6 3/4" Macho & 8" Hembra

**MATERIALS** Siam Oak (*Hevea brasiliensis* Muell.-Arg.)  
Hand selected buffalo heads

**FEATURES** Black powder coated hardware  
8 mm strong tuning lugs  
Interior backing plates

**HB100**  
2 mm rounded rims for playing comfort

**HTB100WB-M**  
5 mm strong TTR-rims

**INCLUDES** Tuning key

**COLOURS** **NT:** Natural, high gloss  
**VSB:** Vintage Sunburst, high gloss  
**VWB-M:** Vintage Wine Barrel, matte  
**WB-M:** Walnut Brown, matte  
**WRB:** Wine Red Burst, high gloss

**2 HEADLINER® SERIES HFB100 FIBERGLASS BONGO**

**SIZES** 6 3/4" Macho & 8" Hembra

**MATERIALS** Premium fiberglass  
Hand selected buffalo heads

**FEATURES** Black powder coated hardware  
8 mm strong tuning lugs  
2.6 mm rounded rims

**INCLUDES** Tuning key

**COLOUR** **BK:** Black

**3 JOURNEY SERIES HB50 BONGO**

**SIZES** 6 1/2" Macho & 7 1/2" Hembra

**MATERIALS** ABS plastic  
Hand selected buffalo heads

**FEATURES** Black powder coated hardware  
Rounded rims for playing comfort

**INCLUDES** Tuning key

**COLOUR** **BK:** Black

**4 BONGO & PERCUSSION PACK**

**CONTAINS** Journey Series HB50 Bongo  
Compact Foot Tambourine  
Luis Conte Live Shaker  
Classic Wood Claves

**5 FWB100 MINI WOOD BONGO**

**SIZES** 3 1/2" Macho & 4 1/4" Hembra

**MATERIALS** Siam Oak (*Hevea brasiliensis* Muell.-Arg.)  
True Skin Buffalo Heads

**FEATURES** MEINL Free Ride Suspension System  
Chrome plated hardware  
2 mm rounded SSR-Rims

**INCLUDES** Tuning key

**COLOUR** **SNT-M:** Super Natural, matte

# HEADLINER®, MARATHON® SERIES & HYBRID TIMBALES

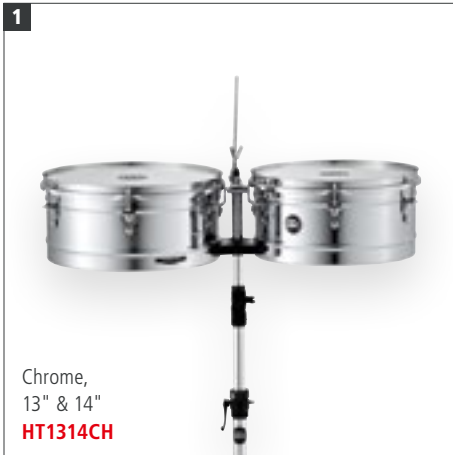

Chrome,  
13" & 14"  
**HT1314CH**



Chrome,  
14" & 15"  
**MT1415CH**

Brass,  
14" & 15"  
**MT1415B**



Black powder coated  
steel, 14" & 15"  
**MTT1415BK**



Black nickel,  
14" & 15"  
**MT1415BN**

Antique Finish,  
14" & 15"  
**MT1415RR-M**

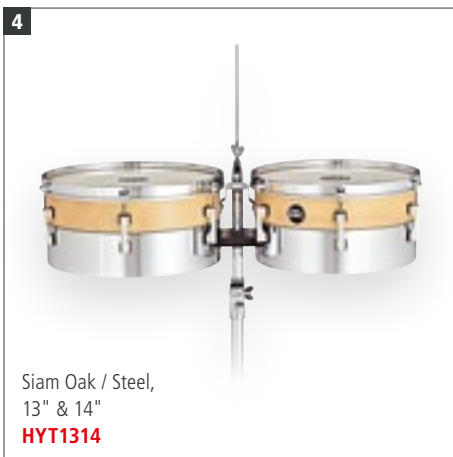

Siam Oak / Steel,  
13" & 14"  
**HYT1314**



MANOLITO RODRIGUEZ, PUERTO RICO



THOUGHTFULLY ARRANGED  
LUGS ENABLE AN EASY  
WAY TO PLAY THE CASCARA

## 1 HEADLINER® SERIES TIMBALES (PATENTED)

**SIZES** 13" & 14"  
**MATERIAL** Steel  
**FEATURES** Logo applied from underneath the head (CN, TH, US patent); Two worked-in flanges  
**INCLUDES** Height adjustable tilting double braced tripod stand; Tuning key; Wrench; Cowbell holder  
**FINISH** Chrome

## 2 MARATHON® SERIES TIMBALES (PATENTED)

**SIZES** 14" & 15"  
**MATERIAL** Steel  
**FEATURES** Two worked-in flanges; Heavy-duty style brackets; Logo applied from underneath the head (CN, TH, US patent)  
**INCLUDES** Adjustable cowbell holder; Height adjustable tilting double braced tripod stand; Accessory pouch; L-shaped tuning key; Tune Up Oil

**FINISHES** **B:** Brass  
**BN:** Black nickel  
**CH:** Chrome  
**RR-M:** Antique Finish, matte

## 3 MARATHON® SERIES TURBO TIMBALES (PATENTED)

**SIZES** 14" & 15", 10" deep  
**MATERIAL** Black powder coated steel  
**FEATURES** Three worked-in flanges; Heavy-duty style brackets; Logo applied from underneath the head (CN, TH, US patent)  
**INCLUDES** Adjustable cowbell holder; Height adjustable tilting double braced tripod stand; Accessory pouch; L-shaped tuning key; Tune Up oil  
**COLOUR** **BK:** Black

## 4 HYBRID TIMBALES (PATENTED)

**SIZES** 13" & 14"

**MATERIALS** Siam Oak (*Hevea brasiliensis* Muell.-Arg.) Steel

**FEATURES** Special designed aluminum brackets; Logo applied from underneath the head (CN, TH, US patent)

**INCLUDES** Adjustable cowbell holder; Height adjustable tilting double braced tripod stand; Accessory pouch; L-shaped tuning key; Tune Up Oil

## ARTIST SERIES TIMBALES (PATENTED)

**5 6 7 8**  
**SIZES** 14" & 15"  
**FEATURE** Logo applied from underneath the head (CN, TH, US patent)  
**INCLUDES** Adjustable cowbell holder; Accessory pouch; L-shaped tuning key; Tune Up Oil

## 5 ARTIST SERIES TIMBALES DIEGO GALÉ

**MATERIAL** Solid brass



**5**

Diego Gale

Solid brass,  
14" & 15"  
**DG1415**

**6**

Luis Conte

Solid brass,  
14" & 15"  
**LC1BRASS**

Stainless steel,  
14" & 15"  
**LC1STS**

**7**

Amadito Valdés

**NEW**

Antique bronze,  
14" & 15"  
**AV1ABR**

**8**

Professional Series

German B8 cymbal  
bronze, 14" & 15"  
**BT1415**

**9**

Taku Hirano

**SPECIAL DESIGNED RIM**

Black powder coated steel, 13"  
**MHT13BK**

**10**

**SNARE WIRES ARE ABSOLUTELY QUIET AND CHATTER-FREE IN THE "OFF" POSITION**

Black powder coated steel, 8"  
**MDST8BK**

Black powder coated steel, 10"  
**MDST10BK**

**11**

Chrome, 8" & 10"  
**MIT810CH**

Chrome, 13"  
**MDT13CH**

**FEATURES** Classic Timbales shape and look; Cascara sound that has the right amount of projection that works in the studio and live situations

**INCLUDES** Professional Timbale Stand

**6 ARTIST SERIES TIMBALES LUIS CONTE**

**MATERIALS** **LC1BRASS:** Solid brass  
**LC1STS:** Stainless steel

**FEATURES** Extensively hammered shells; Two worked-in flanges; Cuban style flared out bottom edge; Brackets cast from special brass alloy

**INCLUDES** Height adjustable tilting double braced tripod stand

**7 ARTIST SERIES TIMBALES AMADITO VALDÉS**

**MATERIAL** Steel

**FEATURES** Two worked-in flanges; Floatune Tuning System

**INCLUDES** Height adjustable tilting double braced tripod stand

**COLOUR** Antique bronze

**8 PROFESSIONAL SERIES TIMBALES**

**MATERIAL** German B8 cymbal bronze

**FEATURES** Two worked-in flanges; Brackets cast from special brass alloy

**INCLUDES** Height adjustable tilting double braced tripod stand

**9 ARTIST SERIES HAND-BALE TAKU HIRANO (PATENTED)**

**SIZE** 13"

**MATERIAL** Black powder coated steel

**FEATURES** Special designed rim; Strong mounting clamp; Logo applied from underneath the head (CN, TH, US patent)

**INCLUDES** L-shaped tuning key; Tune Up Oil

**COLOUR** **BK:** Black, high gloss

**10 DRUMMER SNARE TIMBALES (PATENTED)**

**SIZES** 8", 10"

**MATERIAL** Black powder coated steel

**FEATURES** Strong mounting clamp; Quick snare on/off system; Chatter-free "off" position; Logo applied from underneath the head (CN, US patent)

**INCLUDES** L-shaped tuning key; Tune Up Oil

**COLOUR** **BK:** Black

**11 DRUMMER TIMBALE & MINI TIMBALES (PATENTED)**

**SIZES** **MDT13CH:** 13" (Drummer Timbale)  
**MIT810CH:** 8" & 10" (Mini Timbales)

**MATERIAL** Steel

**FEATURES** Strong mounting clamp; Logo applied from underneath the head (CN, TH, US patent)

**INCLUDES** L-shaped tuning key; Tune Up Oil

**FINISH** Chrome

# COWBELLS & PERCUSSION BLOCKS

**1** BLACK POWDER COATED STEEL

8" **HCO2BK**      5" **HCO4BK**

**2** BLACK POWDER COATED STEEL

8 1/2" **SL850-BK**      6 3/4" **SL675-BK**      5 1/4" **SL525-BK**      4 3/4" **SL475-BK**

**3** EASY MOUNTABLE

2 1/2", 3 1/2", 5" **SLTRI-BK**

**4** CLASSIC ROCK COWBELLS

7" big mouth, low pitch **SCL70B-BK**      4 3/4" high pitch **SCL475-BK**

**TIMBALERO COWBELLS**

8 1/2" low pitch **SCL850-BK**      7" high pitch **SCL70-BK**

**5** HIGH POLISHED CHROME

8" big mouth **STB80B-CH**      8" small mouth **STB80S-CH**      6 1/4" **STB625-CH**      5 1/2" **STB55-CH**      4 1/2" low pitch **STB45L-CH**

**HANDMATE (SEE PAGE 85)**

**HAM1BK**

**HAND BRUSHED STEEL**

8" big mouth **STB80B**      8" small mouth **STB80S**      6 1/4" **STB625**      5 1/2" **STB55**      4 1/2" low pitch **STB45L**      4 1/2" medium pitch **STB45M**      4 1/2" high pitch **STB45H**

## 1 HEADLINER® SERIES COWBELLS

**SIZES** **HCO2BK**: 8" (Timbales Cowbell)  
**HCO4BK**: 5" (Cha Cha Cowbell)

**MATERIAL** Special steel alloy

**FEATURE** Muffled sound

**FINISH** **BK**: Black powder coated

## 2 BLACK FINISH COWBELLS

**SIZES** **SL850-BK**: 8 1/2" (Timbales Cowbell)  
**SL675-BK**: 6 3/4" (Medium Timbales Cowbell)  
**SL525-BK**: 5 1/4" (Cha Cha Cowbell)  
**SL475-BK**: 4 3/4" (Mini Cha Cha Cowbell)

**MATERIAL** Special steel alloy

**FEATURE** Muffled sound

**FINISH** **BK**: Black powder coated

## 3 TRIPLE BELL

**SIZES** 2 1/2", 3 1/2", 5"

**MATERIAL** Special steel alloy

**FEATURE** Muffled sound

**FINISH** **BK**: Black powder coated

## 4 STEEL CRAFT LINE COWBELLS

**SIZES** **SCL70B-BK**: 7" (Classic Rock Cowbell Big Mouth)  
**SCL475-BK**: 4 3/4" (Classic Rock Cowbell)  
**SCL850-BK**: 8 1/2" (Timbalero Cowbell)  
**SCL70-BK**: 7" (Timbalero Cowbell)

**MATERIAL** Special steel alloy

**FEATURES** Steel alloy controls overtones and resonance  
Classic cowbell sound for any setting

**FINISH** **BK**: Black powder coated

## 5 CHROME & STEEL FINISH COWBELLS

**SIZES** **STB80B**: 8" (Timbales Cowbell Big Mouth)  
**STB80S**: 8" (Timbales Cowbell Small Mouth)  
**STB625**: 6 1/4" (Medium Timbales Cowbell)  
**STB55**: 5 1/2" (Cha Cha Cowbell)  
**STB45L**: 4 1/2" (Low Cha Cha Cowbell)  
**STB45M**: 4 1/2" (Medium Cha Cha Cowbell)  
**STB45H**: 4 1/2" (High Cha Cha Cowbell)

**MATERIAL** Special steel alloy

**FEATURE** Tonally matched

**FINISHES** Hand brushed steel  
**CH**: High polished chrome



**6** **HAND BRUSHED GOLD**

8" big mouth **STB80BHH-G**  
6 1/4" **STB625HH-G**

**HAND BRUSHED STEEL**

8" big mouth **STB80BHH-S**  
6 1/4" **STB625HH-S**

**HAND BRUSHED COPPER**

8" big mouth **STB80BHH-C**  
6 1/4" **STB625HH-C**

**7 NEW**

**DEMO VIDEO**

**GROOVE BELL DESIGNED WITH MIKE JOHNSTON**

7 3/4" **MJ-GB**

**8**

**BLACK POWDER COATED STEEL**

8" **BCOB**

**9** **SPECIAL STEEL ALLOY**

8 1/4" **STB815H**  
7 3/4" **STB785H**  
6 1/2" **STB65H**

**10**

**DEMO VIDEO**

**LOOPER BELL DESIGNED WITH YOUNGR**

6 1/2" **YACB**

**11** **COMFORTABLE HOLDER**

6 1/4" **STB625HA-CB**  
4 1/2" **STB45HA-CB**

**DRUM HONEY (SEE PAGE 83)**

**MDH**

**MAGNETIC SUSTAIN CONTROL (SEE PAGE 83)**

**MCT**

**12 NEW**

High pitch **MPE3BK**  
Low pitch **MPE4R**

**6 HAMMERED COWBELLS**

**SIZES** **STB80BHH:** 8" (Timbales Cowbell Big Mouth)  
**STB625HH:** 6 1/4" (Medium Timbales Cowbell)

**MATERIAL** Special steel alloy

**FEATURE** Hammered

**FINISHES** **C:** Hand brushed copper  
**G:** Hand brushed gold  
**S:** Hand brushed steel

**7 ARTIST SERIES COWBELL MIKE JOHNSTON**

**SIZE** 7 3/4"

**MATERIAL** Special steel alloy

**FEATURES** Specifically made for drum set use

**INCLUDES** Two magnets (one small and one large, based on Benny Greb's Magnetic Sustain Control idea)

**FINISH** Vintage Steel

**8 BONGO COWBELL**

**SIZE** 8" (Medium Handheld Cowbell)

**MATERIAL** Special steel alloy

**FEATURES** Muffled sound  
For low volume playing

**FINISH** Black powder coated

**9 HAND COWBELLS**

**SIZES** **STB815H:** 8 1/4" (High Handheld Cowbell)  
**STB785H:** 7 3/4" (Low Handheld Cowbell)  
**STB65H:** 6 1/2" (Mini Handheld Cowbell)

**MATERIAL** Special steel alloy

**FINISH** Hand brushed steel

**10 ARTIST SERIES COWBELL YOUNGR**

**SIZE** 6 1/2"

**MATERIAL** Special steel alloy

**FEATURES** Adjust tone and sustain with hands or included Magnetic Sustain Control  
Unique art and white finish

**INCLUDES** Two magnets (two large, based on Benny Greb's Magnetic Sustain Control idea)

**11 HANDHELD COWBELLS**

**SIZES** **STB625HA-CB:** 6 1/4"  
**STB45HA-CB:** 4 1/2"

**MATERIAL** Special steel alloy

**FEATURE** Comfortable holder

**FINISH** Hand brushed steel

**12 PERCUSSION BLOCKS**









**MATERIAL** PE

**FEATURES** Ultra-durable plastic  
**MPE3BK:** High pitched sound  
**MPE4R:** Low pitched sound

**INCLUDES** Mounting Clamp

**COLOURS** **BK:** Black  
**R:** Red

# PANDEIROS

<p><b>1</b></p> <p>CHROME PLATED STEEL JINGLES</p>  <p>Clear Mylar head, 10" <b>PA10ABS-BK</b></p> <p>Napa head, 10" <b>PA10ABS-BK-NH</b></p>	<p><b>2</b></p> <p>CHROME PLATED STEEL JINGLES</p>  <p>Goatskin head, 10" <b>PA10CN-M</b></p> <p>Goatskin head, 12" <b>PA12CN-M</b></p>	
<p><b>3</b> <b>NEW</b></p> <p>CHROME PLATED STEEL JINGLES</p>  <p>Goatskin head, 10" <b>PA10PW-M</b></p>	<p><b>4</b></p> <p>HAND-HAMMERED BRASS JINGLES</p>  <p>Goatskin head, 10" <b>PA10AB-M</b></p>	<p><b>5</b></p> <p>PERFORATED HAND-HAMMERED BRASS JINGLES</p>  <p>True Feel synthetic head, 10" <b>PAV10AB-M-TF</b></p>
<p><b>6</b> <b>NEW</b></p> <p>UNIQUE SHAKER PODS</p>  <p>Napa head, 10" <b>PAS10PW-NH</b></p>	<p><b>7</b></p> <p>EASY MOUNTABLE</p>  <p>Napa head, 10" <b>PA10A-BK-NH-H</b></p>	<p><b>8</b></p> <p>EASY MOUNTABLE</p>  <p>True Feel synthetic head, 12" <b>PA12CN-M-TF-H</b></p>

## 1 TRADITIONAL ABS PANDEIROS

**SIZE** 10"

**MATERIALS** ABS plastic  
Chrome plated steel jingles  
**PA10ABS-BK**  
Replaceable synthetic head  
**PA10ABS-BK-NH**  
Replaceable Napa head

**FEATURES** Countersunk bolt lugs  
**PA10ABS-BK**: Logo applied from underneath the head (CN, TH, US patent)  
**PA10ABS-BK-NH**: Reduced overtones

**INCLUDES** Tuning key

**COLOUR** **BK**: Black

## 2 TRADITIONAL WOOD PANDEIROS, SIAM OAK

**SIZES** **PA10**: 10"  
**PA12**: 12"

**MATERIALS** Siam Oak (*Hevea brasiliensis* Muell.-Arg.)  
Replaceable hand selected goatskin head  
Chrome plated steel jingles

**FEATURE** Countersunk bolt lugs

**INCLUDES** Tuning key

**COLOUR** **CN-M**: Chestnut, matte

## 3 TRADITIONAL WOOD PANDEIRO, POPLAR WOOD

**SIZE** 10"

**MATERIALS** Poplar Wood (*Populus*)  
Replaceable hand selected goatskin head  
Chrome plated steel jingles

**FEATURE** Countersunk bolt lugs

**INCLUDES** Tuning key

## 4 SHELL-TUNED GOATSKIN PANDEIRO

**SIZE** 10"

**MATERIALS** Siam Oak (*Hevea brasiliensis* Muell.-Arg.)  
Hand selected goatskin head  
Hand-hammered brass jingles

**FEATURES** Internal lug tuning system; Light weight

**INCLUDES** Hex key

**COLOUR** **AB-M**: African Brown, matte

## 5 SHELL-TUNED SYNTHETIC HEAD PANDEIRO

**SIZE** 10"

**MATERIALS** Siam Oak (*Hevea brasiliensis* Muell.-Arg.)  
True Feel synthetic head  
Perforated hand-hammered brass jingles for extra dry sound

**FEATURES** Internal lug tuning system; Light weight

**INCLUDES** Hex key

**COLOUR** **AB-M**: African Brown, matte

# COMPACT WOOD TAMBOURINES

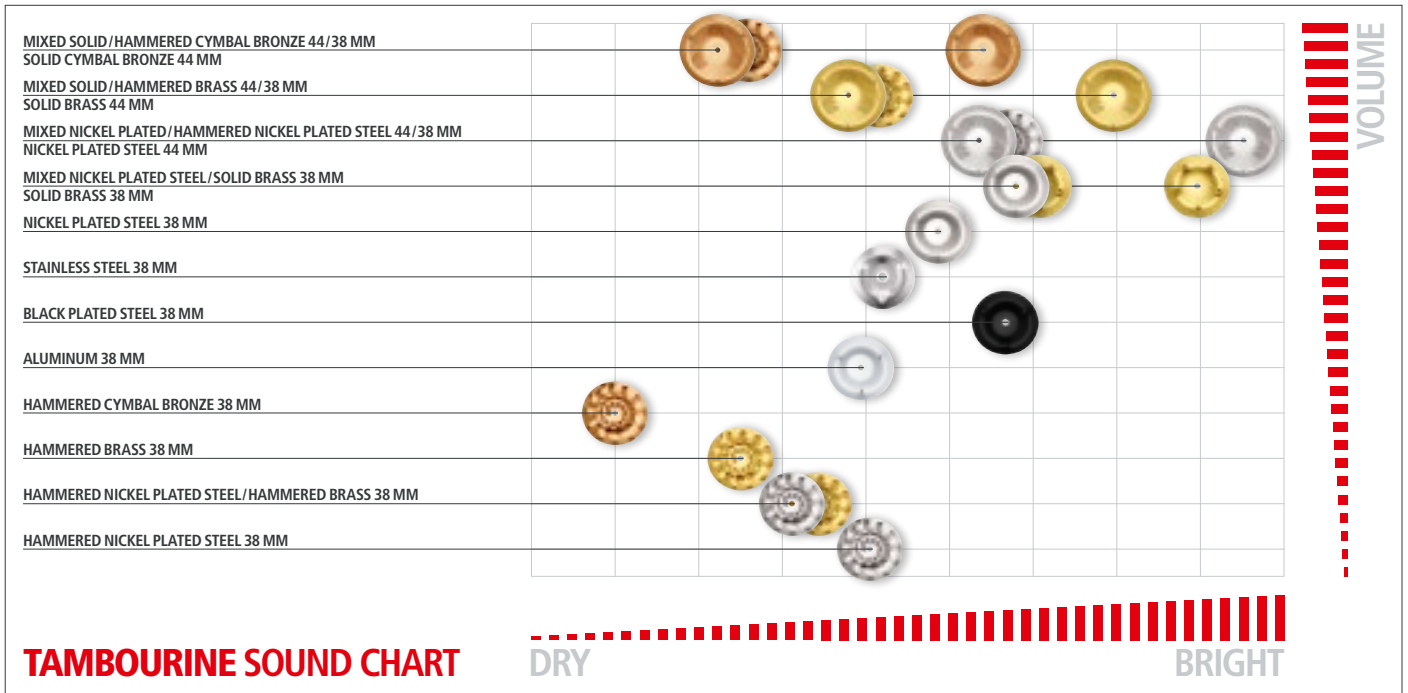

<p><b>9</b></p>  <p><b>HAMMERED BRASS</b></p> <p>3 rows <b>AE-CMTA3B</b></p>	<p><b>10</b></p>  <p><b>NICKEL PLATED STEEL</b></p> <p>2 rows <b>CTA2S-BK</b></p>	 <p><b>MIXED NICKEL PLATED STEEL / SOLID BRASS</b></p> <p>2 rows <b>CTA2M-BK</b></p>	 <p><b>SOLID BRASS</b></p> <p>2 rows <b>CTA2B-BK</b></p>
 <p><b>HAMMERED CYMBAL BRONZE</b></p> <p>3 rows <b>AE-CMTA3BO</b></p>	 <p><b>HAMMERED NICKEL PLATED STEEL</b></p> <p>3 rows <b>AE-CATA3S</b></p>	 <p><b>STAINLESS STEEL</b></p> <p>2 rows <b>CTA2WB</b></p>	 <p><b>MIXED HAMMERED NICKEL PLATED STEEL / BRASS</b></p> <p>2 rows <b>CTA2VM-WB</b></p>

## 6 SHAKER PANDEIRO

**SIZE** 10"  
**MATERIALS** Poplar Wood (*Populus*)  
 Replaceable Napa head  
 Aluminum shaker pods  
**FEATURE** Countersunk bolt lugs  
**INCLUDES** Tuning key

## 7 TRADITIONAL ABS PANDEIRO WITH HOLDER

**SIZE** 10"  
**MATERIALS** ABS plastic  
 Replaceable Napa head  
 Chrome plated steel jingles  
**FEATURES** Countersunk bolt lugs;  
 Reduced overtones; Easy mountable  
**INCLUDES** Tuning key  
**COLOUR** **BK:** Black

## 8 TRADITIONAL WOOD PANDEIRO WITH HOLDER

**SIZE** 12"  
**MATERIALS** Siam Oak (*Hevea brasiliensis* Muell.-Arg.)  
 Replaceable True Feel synthetic head  
 Chrome plated steel jingles  
**FEATURES** Countersunk bolt lugs;  
 Reduced overtones; Easy mountable  
**INCLUDES** Tuning key  
**COLOUR** **CN-M:** Chestnut, matte

## 9 ARTISAN EDITION COMPACT TAMBOURINES

**SIZE** 8"  
**MATERIALS** **AE-CATA3:** American White Ash (*Fraxinus americana* L.)  
**AE-CMTA3:** Maple (*Acer sp.*)  
**B:** Hammered brass jingles  
**BO:** Hammered cymbal bronze jingles  
**S:** Hammered nickel plated steel jingles

**FEATURES** Total unique tambourine sounds;  
 Resounding jingle accents; Special profile jingles;  
 Ergonomic hand grip; Detailed with ornamental heat-branded logo;  
 3 rows of hammered jingles; Extra narrow jingle slots for precise playing

## 10 COMPACT WOOD TAMBOURINES

**SIZE** 8"  
**MATERIALS** Wooden frame  
**CTA2B-BK:** Solid brass jingles  
**CTA2M-BK:** Nickel plated steel / solid brass jingles  
**CTA2S-BK:** Nickel plated steel jingles  
**CTA2VM-WB:** Hammered nickel plated steel / hammered brass jingles  
**CTA2WB:** Stainless steel jingles  
**FEATURES** Compact size; 2 row version  
**COLOURS** **BK:** Black  
**WB:** Walnut Brown

# WOOD TAMBOURINES



## 1 ARTISAN EDITION TAMBOURINES

**SIZE** 10"

**MATERIALS** **AE-ATA:** American White Ash (*Fraxinus americana* L.)  
**AE-MTA:** Maple (*Adcer sp.*)  
**B:** Solid brass jingles  
**BO:** Solid cymbal bronze jingles  
**S:** Nickel plated steel jingles

**FEATURES** Total unique tambourine sounds  
 Resounding tambourine accents  
 Special profile jingles  
 Ergonomic hand grip  
 Detailed with ornamental heat-branded logo  
 1 row and 2 row version

## 2 VINTAGE WOOD TAMBOURINES

**SIZE** 10"

**MATERIALS** Wooden frame  
**TA1V:** Hammered brass jingles

**TA1VM:** Hammered nickel plated steel / hammered brass jingles

**FEATURES** Legendary tambourine sound  
 Special profile jingles  
 Detailed with heat-branded logo  
 1 row and 2 row version

**COLOUR** **WB:** Walnut Brown

## 3 TRADITIONAL WOOD TAMBOURINES

**SIZE** 10"

**MATERIALS** Wooden frame  
**TA1A-AB, TA2A-AB:** Aluminum jingles  
**TA1B-AB, TA2B-AB:** Solid brass jingles  
**TA1AB, TA2AB:** Nickel plated steel jingles  
**TA1WB, TA2WB:** Stainless steel jingles

**FEATURES** 1 row and 2 row version  
**TA1WB, TA2WB:** Detailed with heat-branded logo

**COLOURS** **AB:** African Brown  
**WB:** Walnut Brown

## 4 RECORDING-COMBO WOOD TAMBOURINES

**SIZE** 10"

**MATERIALS** Wooden frame  
 Nickel plated steel / solid brass jingles

**FEATURES** Dual-alloy jingles  
 1 row and 2 row version

**COLOUR** **SNT:** Super Natural

## 5 HEADED ARTISAN EDITION TAMBOURINES

**SIZE** 10"

**MATERIALS** Hand selected calfskin heads  
**AE-ATAH:** American White Ash (*Fraxinus americana* L.)  
**AE-MTAH:** Maple (*Adcer sp.*)  
**B:** Solid / hammered brass jingles  
**BO:** Solid / hammered cymbal bronze jingles  
**S:** Nickel plated / hammered nickel plated steel jingles

**4**

MIXED NICKEL PLATED STEEL / SOLID BRASS

1 row **TA1M-SNT**      2 rows **TA2M-SNT**

**5**

MIXED SOLID / HAMMERED BRASS

MIXED SOLID / HAMMERED CYMBAL BRONZE

MIXED NICKEL PLATED / HAMMERED NICKEL PLATED STEEL

2 rows **AE-MTAH2B**      2 rows **AE-MTAH2BO**      2 rows **AE-ATAH2S**



**6**

HAMMERED BRASS

1 row **TAH1V-WB**      2 rows **TAH2V-WB**

**7**

BLACK PLATED STEEL

1 row **TAH1BK-R-TF**      2 rows **TAH2BK-R-TF**

**8**

MIXED NICKEL PLATED STEEL / SOLID BRASS

1 row **TAH1M-SNT**      2 rows **TAH2M-SNT**

**9**

ALUMINUM

1 row **TAH1A-AB**      2 rows **TAH2A-AB**

SOLID BRASS

1 row **TAH1B-AB**      2 rows **TAH2B-AB**

NICKEL PLATED STEEL

1 row **TAH1AB**      2 rows **TAH2AB**

STAINLESS STEEL

1 row **TAH1WB**      2 rows **TAH2WB**

**FEATURES** Total unique tambourine sounds  
Resounding jingle accents  
Two different profile jingles  
Ergonomic hand grip  
Detailed with ornamental heat-branded logo  
Prepared with Resin

**6 VINTAGE GOATSKIN WOOD TAMBOURINES**

**SIZE** 10"  
**MATERIALS** Wooden frame  
Hand selected goatskin heads  
Hammered brass jingles  
**FEATURES** 1 row and 2 row version  
Legendary tambourine sound  
Special profile jingles  
Detailed with heat-branded logo  
**COLOUR** **WB:** Walnut Brown

**7 TOURING SYNTHETIC HEAD WOOD TAMBOURINES**

**SIZE** 10"  
**MATERIALS** Wooden frame  
True Feel synthetic heads  
Black plated steel jingles  
**FEATURE** 1 row and 2 row version  
**COLOUR** **R:** Red

**8 RECORDING-COMBO GOATSKIN WOOD TAMBOURINES**

**SIZE** 10"  
**MATERIALS** Wooden frame  
Hand selected goatskin heads  
Nickel plated steel / solid brass jingles  
**FEATURES** Dual-alloy jingles  
1 row and 2 row version  
**COLOUR** **SNT:** Super Natural

**9 TRADITIONAL GOATSKIN WOOD TAMBOURINES**

**SIZE** 10"  
**MATERIALS** Wooden frame  
Hand selected goatskin heads  
**TAH1A-AB, TAH2A-AB:** Aluminum jingles  
**TAH1B-AB, TAH2B-AB:** Solid brass jingles  
**TAH1AB, TAH2AB:** Nickel plated steel jingles  
**TAH1WB, TAH2WB:** Stainless steel jingles  
**FEATURES** 1 row and 2 row version  
**TAH1WB, TAH2WB:** Detailed with heat-branded logo  
**COLOURS** **AB:** African Brown  
**WB:** Walnut Brown

# JINGLE STICKS & ABS TAMBOURINES



## 1 HEADLINER® SERIES JINGLE STICKS

**MATERIALS** ABS plastic  
Stainless steel jingles

**COLOURS** **BK:** Black  
**R:** Red

## 2 PROFESSIONAL SERIES JINGLE STICKS

**MATERIALS** ABS plastic  
**JG1:** Nickel plated steel jingles  
**JG1A:** Aluminum jingles  
**JG1B:** Solid brass jingles  
**JG1M:** Nickel plated steel / solid brass jingles

**FEATURES** Padded grip  
Güiro style playing surface

## 3 MULTI-JINGLE STICK

**MATERIALS** ABS plastic  
Nickel plated steel / solid brass jingles

**FEATURES** Jingles mounted on two intersecting planes  
Padded grip  
Special playing techniques

## 4 HEADLINER® SERIES TOUR TAMBOURINES

**SIZES** **HTT8:** 8"  
**HTT10:** 10"

**MATERIALS** ABS plastic  
Stainless steel jingles

**FEATURES** Handheld  
Extra wide grip  
Bright, cutting sound  
Durable frame  
**HTT8:** 1 row version; Compact size  
**HTT10:** 2 row version

**COLOURS** **BK:** Black  
**R:** Red  
**WH:** White

## 5 HEADLINER® SERIES HAND HELD ABS TAMBOURINES

**MATERIALS** ABS plastic  
Stainless steel jingles

**FEATURES** Ergonomic hand grip for more playing comfort  
Güiro style playing surface  
Penetrating jingle sound  
**HTR, HTBK:** 1 row version  
**HTMT1BK:** 2 row version

**COLOURS** **BK:** Black  
**R:** Red



# ABS AND PRAISE & WORSHIP TAMBOURINES



TAMBOURINES



STAINLESS STEEL



NICKEL PLATED STEEL



NICKEL PLATED STEEL



NICKEL PLATED STEEL



ALUMINUM



SOLID BRASS

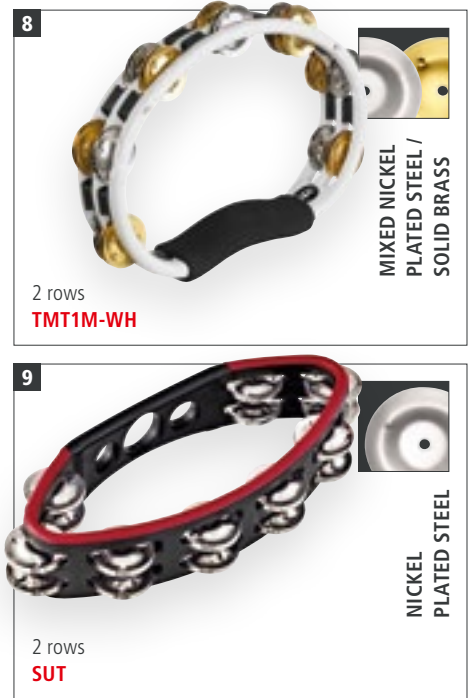

MIXED NICKEL PLATED STEEL / SOLID BRASS

## 6 GOSPEL PRAISE & WORSHIP CHURCH TAMBOURINES

- SIZE 10"
- MATERIALS Durable frame  
Pre-tuned synthetic head  
Nickel plated steel jingles
- FEATURES Perfect for worship settings with a chorus or live band  
1 row and 2 row version
- FINISHES C: Religious Cross  
D: Dove Visual

- FEATURES Padded soft grip for more playing comfort  
Ergonomic design  
Güiro style playing surface  
"Sandwich" construction

- COLOURS B: Blue  
BK: Black  
R: Red

## 8 RECORDING-COMBO HAND HELD ABS TAMBOURINE

- MATERIALS ABS plastic  
Nickel plated steel / solid brass jingles
- FEATURES Padded soft grip for more playing comfort  
Ergonomic design  
Güiro style playing surface  
"Sandwich" construction
- COLOUR WH: White

## 9 SPEED UP TAMBOURINE

- MATERIALS ABS plastic  
Nickel plated steel jingles
- FEATURES Narrow elliptical shape enables fast grooves  
Ideal for fast and energetic styles  
Soft touch edge for comfortable playing feel  
Slender grip area  
Added finger and thumb holes allow you to twirl the tambourine
- COLOUR Black

## 7 TRADITIONAL HAND HELD ABS TAMBOURINES

- MATERIALS ABS plastic  
TMT1A-B: Aluminum jingles  
TMT1B-BK: Solid brass jingles  
TMT1BK, TMT1R: Nickel plated steel jingles

# ABS TAMBOURINES, CHING RINGS & CRASHERS

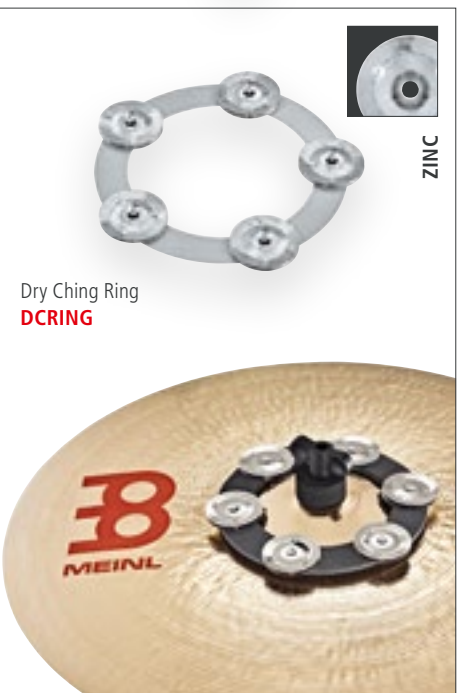
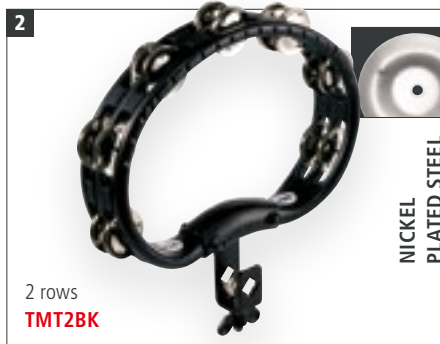

## 1 HEADLINER® SERIES MOUNTABLE ABS TAMBOURINE

**MATERIALS** ABS plastic  
Stainless steel jingles

**FEATURES** Easy mountable  
Güiro style playing surface  
Penetrating jingle sound

**COLOUR** **BK**: Black

## 2 TRADITIONAL MOUNTABLE ABS TAMBOURINES

**MATERIALS** ABS plastic  
**TMT2A-B**: Aluminum jingles  
**TMT2B-BK**: Solid brass jingles  
**TMT2BK, TMT2R**: Nickel plated steel jingles

**FEATURES** Easily mountable  
Ergonomic design  
Güiro style playing surface  
"Sandwich" construction

**COLOURS** **B**: Blue  
**BK**: Black  
**R**: Red

## 3 RECORDING-COMBO MOUNTABLE ABS TAMBOURINE

**MATERIALS** ABS plastic  
Nickel plated steel / solid brass jingles

**FEATURES** Easily mountable  
Ergonomic design  
Güiro style playing surface  
"Sandwich" construction

**COLOUR** **WH**: White

## 4 TURBO CRASHERS

**SIZES** **CRASHER-M**: Medium  
**CRASHER**: Large

**MATERIAL** Steel

**FEATURES** Güiro style playing surface  
Cutting sound  
Easy mountable

## 5 CHING RINGS

**SIZE** 6"

**MATERIALS** **CRING**  
Steel ring  
5 pairs of stainless steel jingles  
**DCRING**  
Steel ring  
5 pairs of zinc jingles  
**SCRING**  
Foam ring  
6 pairs of stainless steel jingles

**FEATURES** Fits on most cymbals  
Quick setup

# HIHAT & BACKBEAT TAMBOURINES



**6** **NEW**



1 row  
**HTHH1BK**

SAND HIHAT TAMBOURINE  
DESIGNED WITH BENNY GREB



**7**



1 row  
**HTHH1BK**

STAINLESS STEEL



2 rows  
**HTHH2BK**

STAINLESS STEEL



1 row  
**HTHH1B-BK**

HAMMERED BRASS



2 rows  
**HTHH2B-BK**

HAMMERED BRASS

**8**



1 row  
**THH1BK**

STAINLESS STEEL



1 row  
**THH1B-BK**

SOLID BRASS

**9**



10" - 12"  
**BBTA1-BK**

STAINLESS STEEL



13" - 14"  
**BBTA2-BK**

**10**



13"  
**BBP13**

SOLID BRASS



14"  
**BBP14**

## 6 BENNY GREB SAND HIHAT TAMBOURINE

- SIZE 5"  
MATERIAL Sand blasted brass jingles  
FEATURES Benny Greb signature hihat tambourine  
Eight pairs of sand blasted brass jingles  
Dry, vintage sound with unique matte appearance  
Blends easily into your natural drum set or percussion mix  
Wing nut design fits on any hihat rod

## 7 HEADLINER® SERIES HIHAT TAMBOURINES

- SIZE 5"  
MATERIALS **HTHH1BK, HTHH2BK:** Stainless steel jingles  
**HTHH1B-BK, HTHH2B-BK:** Hammered brass jingles  
FEATURES 1 row and 2 row version

## 8 PROFESSIONAL SERIES HIHAT TAMBOURINES

- SIZE 5"  
MATERIALS **THH1BK:** Stainless steel jingles  
**THH1B-BK:** Solid brass jingles  
FEATURES Rubber padded surface

## 9 BACKBEAT TAMBOURINES

- SIZES **BBTA1-BK:** For 10" and 12" drums  
**BBTA2-BK:** For 13" and 14" drums  
MATERIALS Eco-friendly medium density fiberboard  
Stainless steel jingles  
FEATURES Fits on any standard drum  
Adds a tambourine sound to the groove  
Hook and loop fastener  
COLOUR **BK:** Black

## 10 BACKBEAT PRO TAMBOURINES

- SIZES **BBP13:** 13"  
**BBP14:** 14"  
MATERIALS Cymbal brass alloy ring  
Solid brass jingles  
FEATURES Blackened brass ring made from MEINL Cymbal Alloy  
Eight pairs of solid brass jingles

# FACE SHAKERS, KEY RING SHAKERS & TAMBOURINES

**1** NEW



Happy Face  
**FACE-H**



Face Shaker Assortment  
**FSA1**



Laughing Face  
**FACE-L**



Poop Face  
**FACE-P**



Sad Face  
**FACE-S**



**2**



Key Ring Tambourine, red  
**KRT-R**



Key Ring Shaker and  
Tambourine Assortment  
**KRA1**



Key Ring Shaker, grey  
**KRS-GR**



Key Ring Tambourine, black  
**KRT-BK**



Key Ring Shaker, black  
**KRS-BK**

## 1 FACE SHAKERS

**MATERIAL** ABS plastic  
**CONTAINS** **FSA1**  
6 x Happy Face  
6 x Laughing Face  
6 x Poop Face  
6 x Sad Face  
**FEATURES** Made of durable ABS plastic  
Loud filling projects clearly  
Great accent for live and studio applications  
**INCLUDES** **FSA1**: Fishbowl  
**GRAPHICS** **FACE-H**: Happy Face  
**FACE-L**: Laughing Face  
**FACE-P**: Poop Face  
**FACE-S**: Sad Face

## 2 KEY RING SHAKERS & TAMBOURINES

**MATERIALS** ABS plastic  
**KRT**: Nickel plated steel  
**CONTAINS** **KRA1**  
10 x Key Ring Shaker  
8 x Key Ring Tambourine  
**FEATURES** Easily detach when it's time to play  
Perfect for acoustic shows or jam sessions  
**INCLUDES** **KRA1**: Fishbowl  
**FINISHES** **BK**: Black  
**GR**: Grey  
**R**: Red

## 3 ORIGINAL SPARK SHAKER

**SIZE** Medium  
**MATERIALS** Shaker: Coated steel  
Pellets: Coated steel  
**FEATURES** Circular motion enables a unique rattling  
Spark Shakers may be played in pairs  
**FINISH** Black nickel

## 4 SPIN SPARK SHAKER

**SIZE** Medium  
**MATERIALS** Shaker: Coated steel  
Pellets: Coated steel  
**FEATURE** Screw-mounted disc enables a tunable pitch  
**FINISH** Black nickel

## 5 CLAMSHELL SPARK SHAKERS

**MATERIAL** Steel  
**FEATURES** Comes in a set of two  
Wildly variable pitch response  
**FINISH** Black nickel

# SPARK, ALUMINUM & FIBERGLASS SHAKERS



SHAKERS

**3** CIRCULAR MOTION ENABLES A UNIQUE RATTLING



Spark shaker  
**SH16**

**4** SCREW-MOUNTED DISC ENABLES A TUNABLE PITCH



Spin spark  
**SH17**

SENSATIONAL EFFECTS ARE PRODUCED WHEN COMBINED WITH ANOTHER SPARK SHAKER



**5** HIGH PITCH & LOW PITCH



Clamshell spark, set of two  
**SH22**

**6**



Headed spark  
**SH18**

**7**



Small  
**SH8BK**

Medium  
**SH88BK**

Large  
**SH888BK**

**8**



**SH7-L-BK**

**9** BY TILTING THE SHAKER 90° TO THE FRONT THE JINGLES START TO CLICK ON THE BEAT



**JS88BK**

**10**



**SH9-L-S**

**11**



**SH25-L-S**

**12** DESIGNED FOR PLAYING PRECISE BEATS AND PATTERNS



**SH23**

## 6 HEADED SPARK SHAKER

**SIZE** Medium  
**MATERIALS** Shaker: Coated steel  
Pellets: Coated steel  
Goatskin head  
**FEATURES** Premium goatskin and a steel shell provide a rattling combination  
Swirling effect  
Variable pitch  
**FINISH** Black nickel

## 7 ALUMINUM SHAKERS, OCTAGONAL

**SIZES** **SH8BK**: Small  
**SH88BK**: Medium  
**SH888BK**: Large  
**MATERIAL** Aluminum  
**FEATURE** Provides a broad dynamic range with lots of volume  
**COLOUR** **BK**: Black

## 8 FIBERGLASS SHAKER

**SIZE** Large  
**MATERIAL** Premium fiberglass  
**FEATURE** Made from premium fiberglass for more durability and better sound quality  
**COLOUR** **BK**: Black

## 9 ALUMINUM JINGLE SHAKER

**SIZE** Medium  
**MATERIALS** Shaker: Aluminum  
Jingles: Steel  
**FEATURE** Two pairs of steel jingles are attached in one row to an octagonal aluminum shaker  
**COLOUR** **BK**: Black

## 10 ALUMINUM SHAKER, ROUND

**SIZE** Large  
**MATERIAL** Anodized aluminum  
**FEATURE** Designed to cut through loud live music  
**COLOUR** **S**: Silver

## 11 PROJECTION SHAKER

**SIZE** Large  
**MATERIAL** Anodized aluminum  
**FEATURES** Designed for comfort and volume  
Shimmering, cutting pitch  
Exceptional for live playing  
**COLOUR** **S**: Silver

## 12 PROTON SHAKER

**MATERIAL** Aluminum  
**FEATURES** Compact size  
Easy to control  
Made for precise playing techniques

# PLASTIC SHAKERS & PERC PACK

**1** **SOFT: STUDIO**



Studio shaker  
**SH5R**



72 - 76 DB

**MEDIUM: LIVE**



Live shaker  
**SH4BK**



79 - 81 DB

**LOUD: STADIUM**



Stadium shaker  
**SH45GR**



88 - 93 DB

**2**



Set, 3 pcs.  
**PP-1**

**3**



SOFT: STUDIO  
Studio shaker  
**SH26-L-S**



LOUD: LIVE  
Live shaker  
**SH26-L-L**

**4**



Medium  
**SH10-M-BK**



Large  
**SH10-L-BK**

**5**



Medium  
**SH12-M-BK**



Large  
**SH12-L-BK**

**6**



Medium  
**SH20BK**

**BY COVERING AND UNCOVERING THE SOUND HOLE, A "WAH-WAH" EFFECT CAN BE ACHIEVED**

**7** **LOUD AND PENETRATING SOUND DUE TO THE MANY HOLES**



**SH3BK**

**8**



Black  
**SH21BK**



Grey  
**SH21GR**

**1 ARTIST SERIES SHAKERS LUIS CONTE**

SIZE Medium  
MATERIAL Plastic  
FEATURES Two individual shakers connected as one instrument  
**SH4BK**: Perfect for live playing  
**SH45GR**: Perfect for stadium situations  
**SH5R**: Perfect for studio recordings  
COLOURS **BK**: Black  
**GR**: Grey  
**R**: Red

**2 PERC PACK**

CONTAINS Compact Foot Tambourine  
Luis Conte Live Shaker  
Classic Wood Claves  
FEATURES Compact Foot Tambourine for hands free use  
Luis Conte Live Shaker for smooth sound  
Classic Wood Claves for traditional rhythms

**3 CRYSTAL SHAKERS**

SIZE Large  
MATERIALS Plastic  
Acrylic  
FEATURES Shapes any groove with clarity and feel  
**SH26-L-L**: Perfect for live playing  
**SH26-L-S**: Perfect for studio recordings

**4 STUDIO SHAKERS**

SIZES **SH10-M-BK**: Medium  
**SH10-L-BK**: Large  
MATERIAL Plastic  
FEATURE Deliver a very tasteful and delicate shaker sound with a warm tone and well balanced frequency spectrum  
COLOUR **BK**: Black

**5 STUDIOMIX SHAKERS**

SIZES **SH12-M-BK**: Medium  
**SH12-L-BK**: Large  
MATERIAL Plastic  
FEATURE Textured surface for special sound and positive grip  
COLOUR **BK**: Black

**6 WAKAH SHAKER**

SIZE Medium  
MATERIALS Wooden body and plastic chamber  
FEATURE By covering and uncovering the sound hole, a "wah-wah" effect can be achieved  
COLOUR **BK**: Black

# EGG SHAKERS



**9**

COMES IN A SET OF TWO

Black  
**ES2-BK**

Red  
**ES2-R**

Blue  
**ES2-B**

Yellow  
**ES2-Y**

Green  
**ES2-GREEN**

**10**

RANGE OF VOLUME FROM SOFT TO EXTRA LOUD

SOFT

LOUD

MEDIUM

EXTRA LOUD

Set, 4 pcs.  
**ES-SET**

**11**

EGG SHAKER ASSORTMENT

Set, 60 pcs.  
**ES-BOX**



MOTION SHAKERS (SEE PAGE 17)

**MS-BK**

**MS-GR**

FOOT SHAKER (SEE PAGE 18)

**FS-BK**

HEEL SHAKER (SEE PAGE 18)

**HSH**

**7 LOOP SHAKER**

SIZE Medium  
 MATERIAL Plastic  
 FEATURE Loud and penetrating sound due to the many holes  
 COLOUR **BK:** Black

**8 U.F.O. SHAKERS**

SIZE Medium  
 MATERIAL Plastic  
 COLOURS **BK:** Black  
**GR:** Grey

**9 EGG SHAKER PAIRS**

MATERIAL Plastic  
 FEATURE Comes in a set of two  
 COLOURS **B:** Blue  
**BK:** Black  
**GREEN:** Green  
**R:** Red  
**Y:** Yellow

**10 EGG SHAKER SET**

MATERIAL Plastic  
 FEATURE Range of volume from soft to extra loud

**11 EGG SHAKER BOX**

CONTAINS Holds 60 Egg Shakers:  
 20 x Egg Shaker, Blue (B)  
 10 x Egg Shaker, Black (BK)  
 10 x Egg Shaker, Green (GREEN)  
 10 x Egg Shaker, Red (R)  
 10 x Egg Shaker, Yellow (Y)

# WOOD SHAKERS, DOUBLE SHAKER/GANZA & CAXIXIS

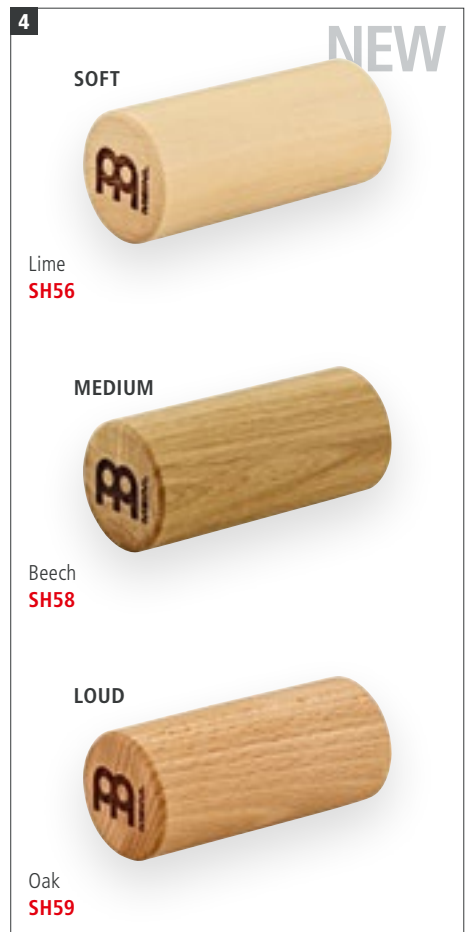

## 1 MINI CAJON SHAKERS

**SIZE** 2" W x 2 3/4" H x 2" D

**MATERIALS** Resonating body: Baltic Birch (*Betula pendula*)  
**SH50**  
Frontplate: Baltic Birch (*Betula pendula*)  
**SH51**  
Frontplate: Ovangkol (*Guibourtia ehie*)

**FEATURES** Compact size  
Cutting shaker sound  
Miniature size of a MEINL cajon

## 2 MINI CAJON SHAKER SET

**MATERIALS** Resonating body: Baltic Birch (*Betula pendula*)  
Frontplates: Exotic Zebrawood, Burl Wood, Baltic Birch (*Betula pendula*)

**FEATURES** Three unique timbres for multiple sound options  
Various frontplates for easy identification

## 3 WOOD SHAKERS, RECTANGLE

**SIZES** **S:** Small  
**M:** Medium

**MATERIALS** Baltic Birch (*Betula pendula*)  
Top and Bottom: Exotic Zebrawood

**FEATURES** Wide sound options  
Rectangle shaped

## 4 WOOD SHAKERS, ROUND

**SIZE** 4" length, 1 3/4" diameter

**MATERIALS** **SH56:** Lime  
**SH58:** Beech  
**SH59:** Oak

**FEATURES** Made from three wood species for different volume  
Fits comfortably in your hand  
**SH56:** Soft  
**SH58:** Medium  
**SH59:** Loud

## 5 DOUBLE SHAKER/GANZA

**MATERIALS** Rattan with coconut bottom

**FEATURES** **D01:** Offers two different sounds in one instrument  
**GA2:** Crystal clear sound, high pitched with a great projection

## 6 CAXIXIS

**SIZES** **CAX1:** Small  
**CAX2:** Medium  
**CAX3:** Large

**MATERIALS** Rattan with coconut bottom

**FEATURES** Crystal clear sound, high pitched with a great projection  
Woven by hand with a coconut bottom



# MARACAS

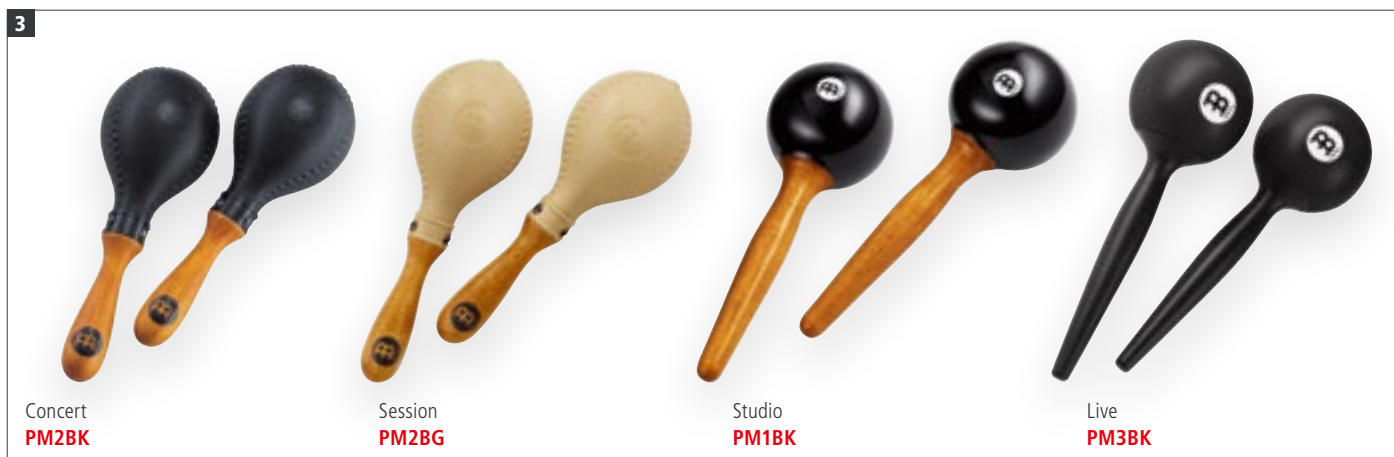

## 1 RAWHIDE MARACAS

**SIZES** **MSM2:** Mini  
**MSM3:** Traditional  
**MSM4:** Jumbo

**MATERIALS** Natural rawhide and wooden handle

**FEATURES** Entirely made by hand  
Offers a wide sonic range  
Durable construction

## 2 PLASTIC EGG MARACAS

**SIZE** 6"

**MATERIAL** Plastic

**FEATURE** Ergonomically shaped handle

## 3 STUDIO, CONCERT, LIVE, SESSION MARACAS

**MATERIAL** Plastic heads

**FEATURE** Ergonomically shaped handle

**COLOURS** **BG:** Beige  
**BK:** Black

## 4 WOOD MARACAS

**MATERIAL** Wood

**FEATURES** Produces a traditional warm and rich sound  
Available in both round and oval models

## 5 MARACLAVES

**MATERIALS** American Ash wood (*Fraxinus americana* L.)  
Plastic shaker head

**FEATURES** Can be played like maracas and claves at the same time  
Precise and cutting sounds  
Durable construction  
Detailed with logo heat-branded on handle

**COLOUR** **BG:** Beige



NATE WERTH, USA

# ALUMINUM SURDOS

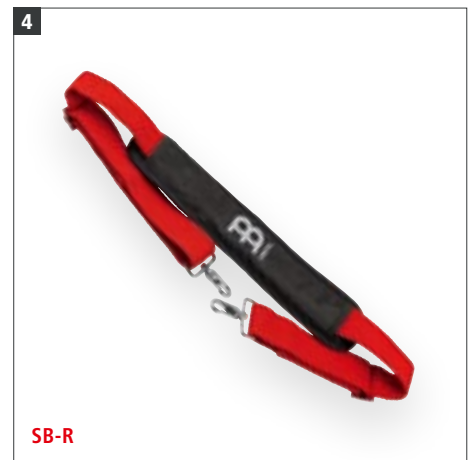

## 1 CLASSIC SERIES SURDOS (PATENTED)

**SIZES** **SUC16:** 16" diameter, 20" tall  
**SUC18:** 18" diameter, 22" tall  
**SUC20:** 20" diameter, 24" tall

**MATERIAL** Aluminum

**FEATURES** Countersunk bolt heads  
Traditional rim  
Chrome plated hardware  
Traditional plain shell  
8 tuning lugs (16" & 18" models)  
10 tuning lugs (20" model)  
Logo applied from underneath the head  
(CN, TH, US patent)

**INCLUDES** Tuning key

## 2 BAHIA ALUMINUM SURDOS (PATENTED)

**SIZES** **SUB18:** 18" diameter, 16" tall  
**SUB20:** 20" diameter, 16" tall  
**SUB22:** 22" diameter, 18" tall

**MATERIAL** Aluminum

**FEATURES** Countersunk bolt heads  
Chrome plated hardware  
Two head options  
8 tuning lugs (18" model)  
10 tuning lugs (20" & 22" models)  
Logo applied from underneath the head  
(CN, TH, US patent)

**INCLUDES** Tuning key

## 3 TRADITIONAL ALUMINUM SURDOS (PATENTED)

**SIZES** **SU16:** 16" diameter, 20" tall  
**SU18:** 18" diameter, 22" tall  
**SU20:** 20" diameter, 24" tall  
**SU22:** 22" diameter, 24" tall

**MATERIAL** Aluminum

**FEATURES** Countersunk bolt heads  
Chrome plated hardware  
Two head options  
8 tuning lugs (16" & 18" models)  
10 tuning lugs (20" & 22" models)  
Logo applied from underneath the head  
(CN, TH, US patent)  
**SU22-L, SU20-L, SU18-L, SU16-L:**  
Height adjustable legs

**INCLUDES** Tuning key



22" **HEAD-69**      20" **HEAD-68**      18" **HEAD-67**      16" **HEAD-66**



SHORTER SHELLS ENABLE TO WEAR IN MUCH LOWER POSITION

22" **SUB22AB-M**      20" **SUB20AB-M**      18" **SUB18AB-M**



22" **SU22AB-M**      20" **SU20AB-M**      18" **SU18AB-M**      16" **SU16AB-M**

SIX-PLY HARDWOOD SHELLS FOR A FULL AND WARM SOUND



22" **SU22-L-AB-M**      20" **SU20-L-AB-M**      18" **SU18-L-AB-M**      16" **SU16-L-AB-M**

HEIGHT ADJUSTABLE LEGS

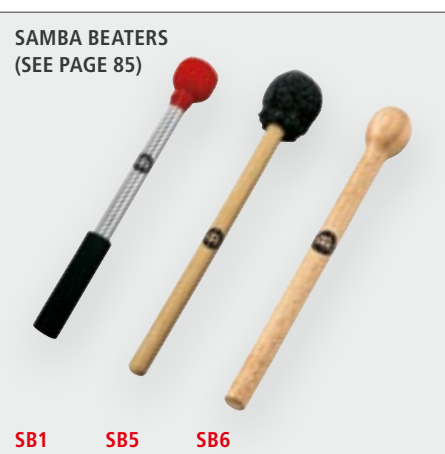

SAMBA BEATERS (SEE PAGE 85)

**SB1**      **SB5**      **SB6**



RITMO FACTORY, CZECH REPUBLIC

#### 4 SAMBA BELT

**MATERIAL** Cotton  
**FEATURES** Length adjustable  
 Adjustable shoulder padding  
 Strong attachment hooks  
**COLOUR** **R:** Red

#### 5 SURDO NAPA HEADS

**SIZES** **HEAD-66:** 16"  
**HEAD-67:** 18"  
**HEAD-68:** 20"  
**HEAD-69:** 22"  
**MATERIALS** Nylon and leather cloth  
**FEATURE** Bonded in a hoop  
**COLOUR** Black

#### 6 BAHIA WOOD SURDOS (PATENTED)

**SIZES** **SUB18:** 18" diameter, 16" tall  
**SUB20:** 20" diameter, 16" tall  
**SUB22:** 22" diameter, 18" tall  
**MATERIAL** Six-ply hardwood shells  
**FEATURES** Countersunk bolt heads  
 Chrome plated hardware  
 Two head options  
 8 tuning lugs (18" model)  
 10 tuning lugs (20" & 22" models)  
 Logo applied from underneath the head (CN, TH, US patent)  
**INCLUDES** Tuning key  
**COLOUR** **AB:** African Brown  
**FINISH** Matte

#### 7 TRADITIONAL WOOD SURDOS (PATENTED)

**SIZES** **SU16:** 16" diameter, 20" tall  
**SU18:** 18" diameter, 22" tall  
**SU20:** 20" diameter, 24" tall  
**SU22:** 22" diameter, 24" tall  
**MATERIAL** Six-ply hardwood shells  
**FEATURES** Countersunk bolt heads  
 Chrome plated hardware  
 Two head options  
 8 tuning lugs (16" & 18" models)  
 10 tuning lugs (20" & 22" models)  
 Logo applied from underneath the head (CN, TH, US patent)  
**SU22-L, SU20-L, SU18-L, SU16-L:** Height adjustable legs  
**INCLUDES** Tuning key  
**COLOUR** **AB:** African Brown  
**FINISH** Matte

# TIMBAS, TANTAM, REBOLO, REPINIQUES & CUICAS

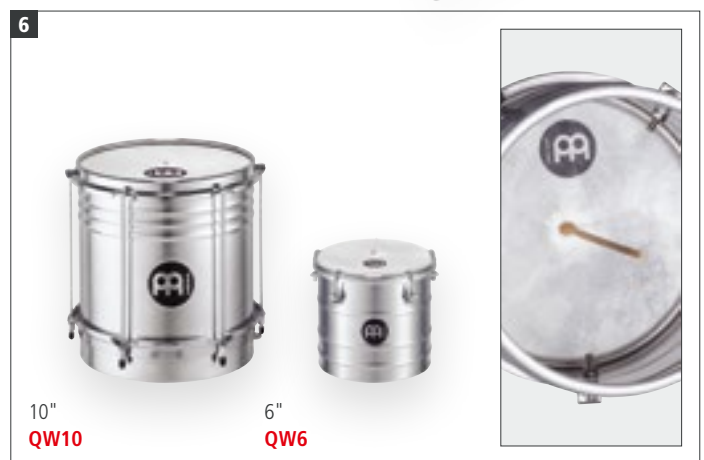
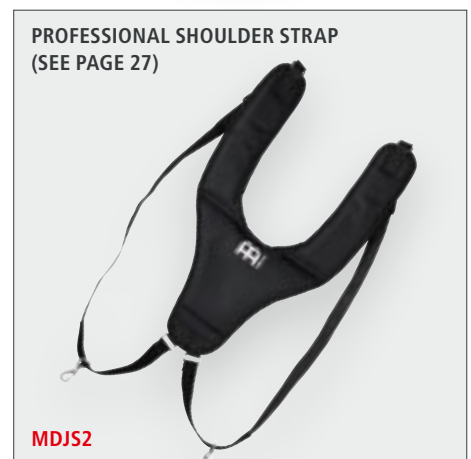
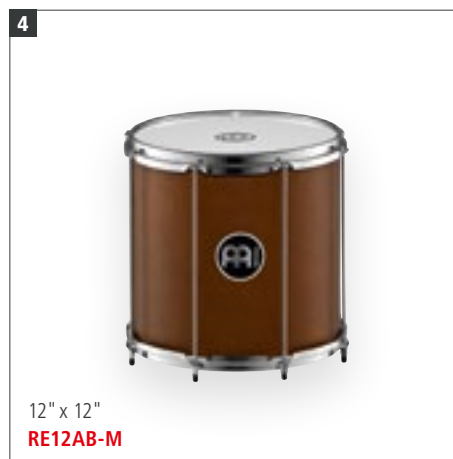
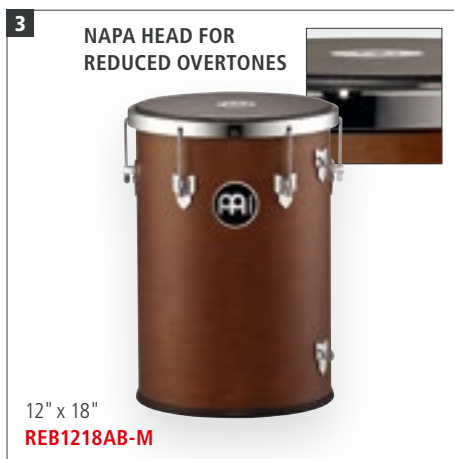
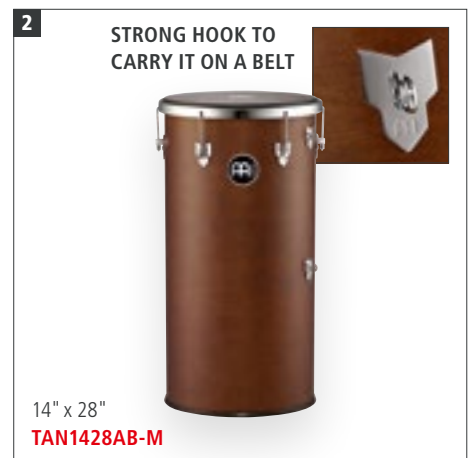

## 1 TIMBAS (PATENTED)

**SIZES** **TIM1428:** 14" diameter, 28" tall  
**TIM1435:** 14" diameter, 35" tall

**MATERIALS** Poplar Wood (*Populus*)

Replaceable synthetic head

**FEATURES** Lightweight shell; Chrome plated hardware; Comfortable rounded rim; Strong hook to carry it on a belt; Logo applied from underneath the head (CN, TH, US patent)

**INCLUDES** Tuning key

**COLOURS** **AB:** African Brown, matte  
**NT:** Natural, high gloss

## 2 TANTAM

**SIZE** 14" diameter, 28" tall

**MATERIALS** Poplar Wood (*Populus*)

Replaceable synthetic Napa head

**FEATURES** Lightweight shell; Chrome plated hardware; Strong hooks to carry it on a belt

**INCLUDES** Tuning key

**COLOUR** **AB:** African Brown, matte

## 3 REBOLO

**SIZE** 12" diameter, 18" tall

**MATERIALS** Poplar Wood (*Populus*)

Replaceable synthetic Napa head

**FEATURES** Lightweight shell; Chrome plated hardware; Mechanical lug tuning; Strong hooks to carry it on a belt

**INCLUDES** Tuning key

**COLOUR** **AB:** African Brown, matte

## REPINIQUES 4 5

**FEATURES** Countersunk bolt heads; Chrome plated hardware; 6 tuning lugs (10" model); 8 tuning lugs (12" model); Logo applied from underneath the head (CN, TH, US patent)

**INCLUDES** Tuning key

## 4 WOOD REPINIQUE (PATENTED)

**SIZE** 12" diameter, 12" tall

**MATERIALS** Siam Oak (*Hevea brasiliensis* Muell.-Arg.)

Replaceable synthetic heads

**COLOUR** **AB:** African Brown, matte

## 5 ALUMINUM REPINIQUES (PATENTED)

**SIZES** **RE10:** 10" diameter, 10" tall

**RE12:** 12" diameter, 12" tall

**MATERIALS** Aluminum

Replaceable synthetic heads

## 6 ALUMINUM CUICAS

**SIZES** **QW6:** 6" diameter

**QW10:** 10" diameter

**MATERIALS** Aluminum

Hand selected goatskin heads

**FEATURE** **QW10:** Countersunk bolt heads

**INCLUDES** Tuning key

# CAIXAS, TAMBORIMS & TAMPEIRO



SAMBA

**7** **PROFESSIONAL SNARE THROW-OFF MECHANISM**



14" x 4"  
**CA14**

12" x 4 1/2"  
**CA12**

**8** **TRADITIONAL STYLE WITH GUITAR STRINGS**



12" x 6"  
**CA12T**

**9** **MESH HEAD FOR SUPER LOW VOLUME PRACTICE**



ABS, Black  
**STBR06ABS-BK**

**10**



ABS, Black  
**TBR06ABS-BK**



ABS, Green  
**TBR06ABS-GR**

**TAMBORIM STICKS (SEE PAGE 84)**



**TBRs-BK**      **TBRs-R**



ABS, Red  
**TBR06ABS-R**



ABS, Yellow  
**TBR06ABS-Y**

**PROFESSIONAL TAMBORIM BAG (SEE PAGE 98)**



**MTAB-06**



Aluminum  
**TBR06ALU**

**11**



Siam Oak, African Brown  
**TP06AB-M**

**7 ALUMINUM CAIXAS (PATENTED)**

**SIZES** **CA12:** 12" diameter, 4 1/2" tall  
**CA14:** 14" diameter, 4" tall

**MATERIALS** Aluminum; Replaceable synthetic heads

**FEATURES** Countersunk bolt heads; Steel snare wires; Professional snare throw-off mechanism; Logo applied from underneath the head (CN, TH, US patent)

**INCLUDES** Tuning key

**8 TRADITIONAL ALUMINUM CAIXA (PATENTED)**

**SIZE** 12" diameter, 6" tall

**MATERIALS** Aluminum; Replaceable synthetic heads

**FEATURES** Traditional style snares made from guitar strings; Extra deep body; Countersunk bolt heads; Logo applied from underneath the head (CN, TH, US patent)

**INCLUDES** Tuning key

**9 SILENT TAMBORIM**

**SIZE** 6" diameter

**MATERIALS** ABS plastic

**FEATURE** Replaceable mesh head

**FEATURE** Floatune Tuning System; Countersunk bolt lugs; Mesh head for super low volume practice

**INCLUDES** Washer as tuning key

**COLOUR** **BK:** Black

**10 FLOATUNE TAMBORIMS (PATENTED)**

**SIZE** 6" diameter

**MATERIALS** Replaceable synthetic heads  
**ABS:** ABS  
**ALU:** Aluminum

**FEATURES** Floatune Tuning System; Countersunk bolt lugs; Logo applied from underneath the head (CN, TH, US patent)

**INCLUDES** Washer as tuning key

**COLOURS** **BK:** Black  
**GR:** Green  
**R:** Red  
**Y:** Yellow

**11 TAMPEIRO (PATENTED)**

**SIZE** 6" diameter

**MATERIALS** Siam Oak (*Hevea brasiliensis* Muell.-Arg.)

**FEATURES** Replaceable synthetic head; Three pairs of steel jingles; Floatune Tuning System; Countersunk bolt lugs; Logo applied from underneath the head (CN, TH, US patent)

**INCLUDES** Washer as tuning key

**COLOUR** **AB:** African Brown

# WHISTLE, TRIANGLE, ROCARS, SHAKERS & A-GO-GOS

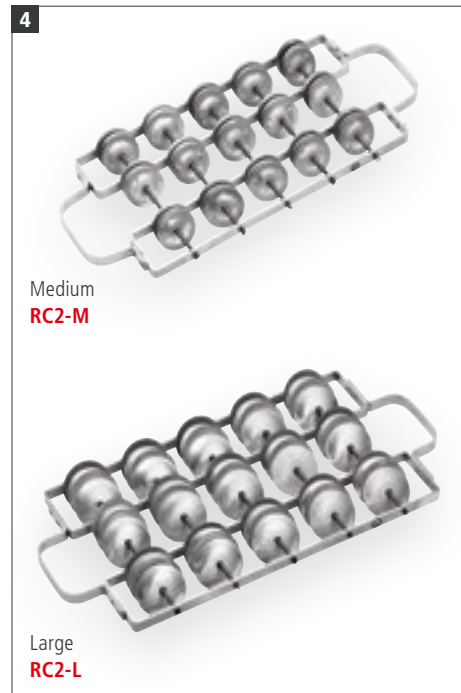
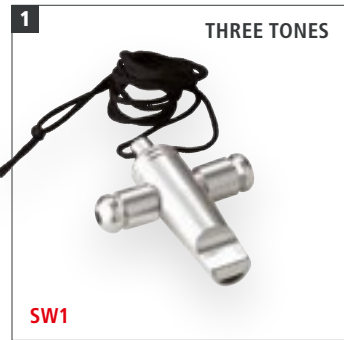

## 1 SAMBA WHISTLE

**MATERIAL** Aluminum  
**INCLUDES** Neck lanyard

## 2 SAMBA TRIANGLE

**SIZE** 15 3/4"  
**MATERIAL** Steel  
**FEATURE** Thick steel for extra volume  
**INCLUDES** Extra large Triangle Beater

## 3 MODERN STYLE ROCAR

**MATERIAL** Siam Oak (*Hevea brasiliensis* Muell.-Arg.)  
**FEATURE** 20 pairs of solid jingles  
**COLOUR** **BK:** Black

## 4 ALUMINUM ROCARS

**SIZES** **RC2-M:** Medium  
**RC2-L:** Large  
**MATERIAL** Aluminum frame and jingles  
**FEATURES** Light weight frame; Loud projection

## 5 ALUMINUM SAMBA SHAKERS

**SIZES** **S:** Small  
**M:** Medium  
**L:** Large

**MATERIAL** Aluminum  
**FEATURE** Produces warm and cutting shaker sound

## 6 MODERN STYLE A-GO-GO STEEL FINISH MODELS

**SIZES** **STBAG1, STBAG5:** Small  
**STBAG2:** Large  
**MATERIAL** Special steel alloy  
**FEATURE** Tonally matched  
**INCLUDES** **STBAG1:** Mounting clamp  
**FINISHES** **STBAG1, STBAG2:** Hand brushed steel  
**STBAG5:** Black powder coating

## 7 MODERN STYLE A-GO-GO CHROME FINISH MODELS

**SIZES** **STBAG4:** Small  
**STBAG2:** Large  
**MATERIAL** Special steel alloy  
**FEATURES** Flexible connection; Bright sound  
**FINISH** High polished chrome

## 8 TRADITIONAL STYLE A-GO-GO BELL

**SIZE** Medium  
**MATERIAL** Special steel alloy  
**FEATURES** Traditional shape; Flexible connection  
**FINISH** High polished chrome

## 9 TRIPLE A-GO-GO BELL

**SIZE** Medium  
**MATERIAL** Chrome plated steel  
**FEATURES** Traditional Shape; Three tonally matched bells in equal intervals; Spring handle enables counterpoint rhythms

# GÜIRAS, GÜIROS & WOOD BLOCKS



SAMBA & HAND PERCUSSION



X-Small  
**MGU4**

Small  
**MGU3**

Medium  
**MGU2**

Large  
**MGU1**

**MGU51**

COME WITH SCRAPER



High strength plastic  
**GU9**

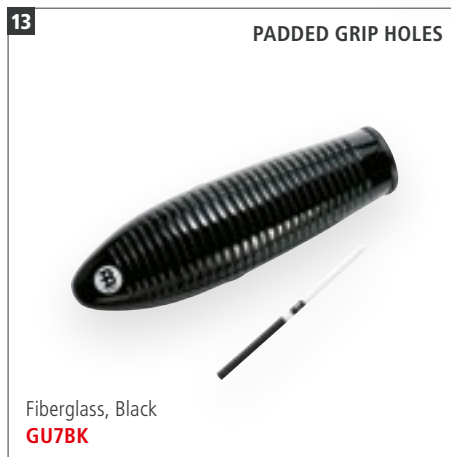

Fiberglass, Black  
**GU7BK**



Wood, Amber  
**GU1AM**



Large  
**PMWB1-L**

Medium  
**PMWB1-M**



Medium  
**MWB1BK**

Large  
**MWB2BK**

## 10 MERENGUE GÜIRAS

**SIZES** **MGU4**: X-Small  
**MGU3**: Small  
**MGU2**: Medium  
**MGU1**: Large

**MATERIAL** Brushed steel

**FEATURES** Scraping surface with uniform raised bumps  
One-piece metal grip with welded flanges

**INCLUDES** ABS scraper MGS2

## 11 MERENGUE GÜIRA SHAKER

**MATERIAL** Brushed steel

**FEATURES** Filling inside to produce a cutting shaker effect  
Scraping surface with uniform raised bumps  
One-piece metal grip with welded flanges

**INCLUDES** ABS scraper MGS2

## 12 TURBO GÜIRO

**MATERIAL** High strength plastic

**FEATURES** Three striking surfaces  
Rubber ringed grip holes

**INCLUDES** Plastic Scraper

## 13 FIBERGLASS GÜIRO

**MATERIAL** Premium fiberglass

**FEATURES** Three striking surfaces  
Padded grip holes

**INCLUDES** Plastic Scraper

**COLOUR** **BK**: Black

## 14 WOOD GÜIRO

**MATERIAL** Wood

**FEATURE** Grip holes

**INCLUDES** Wooden scraper

**COLOUR** **AM**: Amber

## 15 PROFESSIONAL WOOD BLOCKS

**SIZES** **M**: Medium

**L**: Large

**MATERIALS** Select Hardwood top

Siam Oak body

(*Hevea brasiliensis* Muell.-Arg.)

**FEATURES** Well defined fundamental sound  
Detailed with heat-branded logo

## 16 WOOD BLOCKS

**SIZES** **MWB1BK**: Medium

**MWB2BK**: Large

**MATERIAL** Siam Oak (*Hevea brasiliensis* Muell.-Arg.)

**FEATURE** Rounded playing surface

**INCLUDES** Wooden beater

**COLOUR** **BK**: Black, matte

# CABASAS, SLEIGH BELLS & KALIMBAS

**1** ADJUSTABLE NET FOR VARIOUS TENSIONS AND SOUND OPTIONS



CA7BR

**2** PORTS FOR MORE VOLUME (PATENTED)



Large CA5BK-L Medium CA5BK Small CA5BK-S X-Small PCA5BK-XS

**3** STEEL BELLS



25 bells SLB25 12 bells SLB12 7 bells SLB7

**PICKUP KALIMBA (SEE PAGE 03)**



KA9P-AB

**4**



Small KA5-S Medium KA7-M-BK Medium KA9-M

**5** WIDE OPENING FOR GREAT WAH-WAH EFFECTS



Medium KA9WW-BK

## 1 CABASA, FIBERGLASS

**MATERIAL** Premium fiberglass  
**FEATURES** Adjustable net for various tensions and sound options  
 Equals a traditional gourd calabash  
**COLOUR** BR: Brown

## 2 TURBO CABASAS (PATENTED)

**SIZES** PCA5BK-XS: X-Small  
 CA5BK-S: Small  
 CA5BK: Medium  
 CA5BK-L: Large  
**MATERIALS** Steel chain and stainless steel cylinder  
 CA: Wooden handle with padded soft grip  
 PCA: Synthetic grip  
**FEATURE** 5 sound ports on each side for more volume (CN, DE, US patent)  
**COLOUR** BK: Black

## 3 SLEIGH BELLS

**SIZES** SLB7: 7 bells  
 SLB12: 12 bells  
 SLB25: 25 bells  
**MATERIALS** Steel bells  
 Wooden handle  
**FEATURES** Ergonomic grip  
 True sleigh bell sound

## 4 SOLID KALIMBAS

**SIZES** KA5-S: Small  
 KA7-M-BK: Medium  
 KA9-M: Medium  
**MATERIALS** Chrome plated steel  
 New Zealand Pine (*Pinus radiata*)  
**TUNING** KA5-S: g#'' c'' f'' f'' c''  
 KA7-M-BK: e' g d'' e' c' a'  
 KA9-M: a' c'' c' a' A' f' e'' b'

**FEATURES** Ergonomic shape  
 KA5-S, KA9-M: Detailed with heat-branded logo  
 KA7-M-BK: Extra wide tongues for comfort

## 5 WAH-WAH KALIMBA

**SIZE** Medium  
**MATERIALS** Chrome plated steel  
 New Zealand Pine (*Pinus radiata*)  
**TUNING** a' c'' c' a' A' f' e'' b'  
**FEATURE** Wah-wah effect  
**COLOUR** BK: Black



# CASTANETS & CLAVES



HAND PERCUSSION

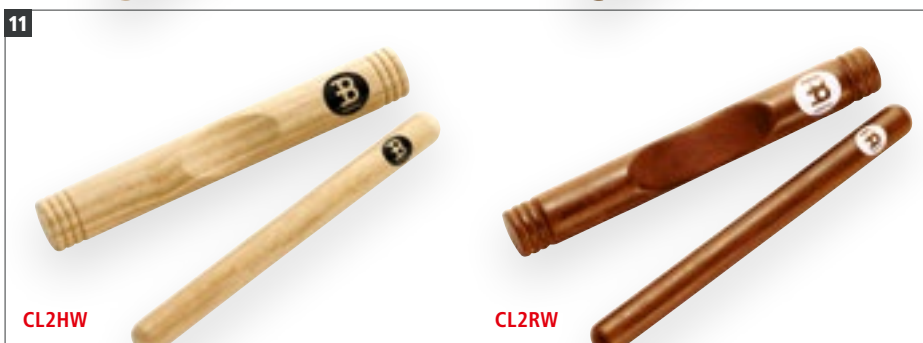
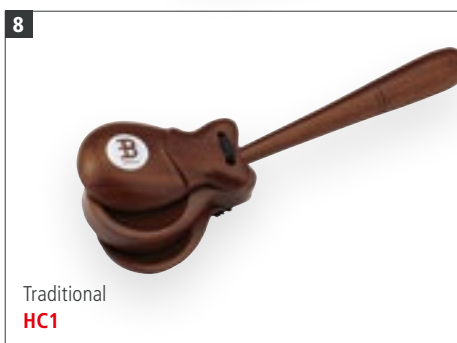

## 6 CASTANET MACHINE

SIZE 7 1/2" x 5"  
 MATERIAL Indian Rosewood  
 FEATURES Separately adjustable  
 Full and cutting resonance

## 7 FINGER CASTANETS

SIZES **FC1**: Traditional  
**FC2**: Concert  
 MATERIAL Indian Rosewood  
 FEATURE Full and cutting resonance

## 8 TRADITIONAL HAND CASTANET

SIZE Traditional  
 MATERIAL Indian Rosewood  
 FEATURES Balanced handle  
 Precisely formed contours for clear, distinct sound

## 9 WOOD CLAVES, CLASSIC

MATERIALS **HW**: Hardwood  
**RW**: Select Hardwood  
 FEATURE Solid body

## 10 CLAVES DE LUXE

SIZE 6 3/4" long  
 MATERIAL Dense hardwood  
 FEATURES Cutting sound  
 Convenient carrying

## 11 WOOD CLAVES, AFRICAN

MATERIALS **HW**: Hardwood  
**RW**: Select Hardwood  
 FEATURES **CL2**: Solid body  
**CL3**: Hollowed out body

# SOUND EFFECTS

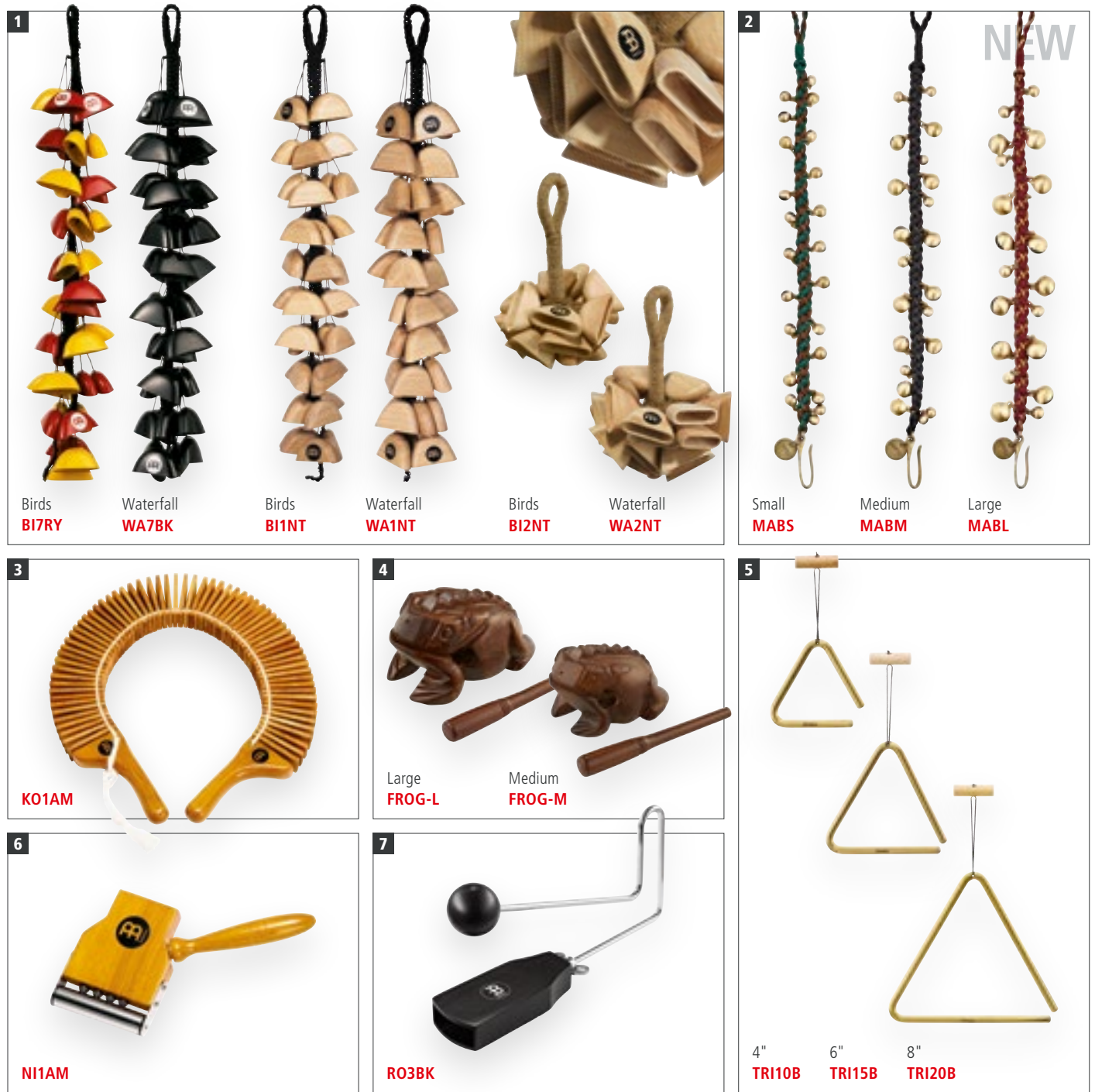

## 1 BIRDS & WATERFALLS

**MATERIALS** **B17RY, WA7BK:** Premium fiberglass  
**B11NT, WA1NT, B12NT, WA2NT:** Siam Oak (*Hevea brasiliensis* Muell.-Arg.)

**FEATURES** Durable cord  
**BI:** Realistically imitate the sound of a flock of birds; Bright sound with big dynamic range  
**WA:** Realistically imitate the sound of a rippling waterfall

**COLOURS** **BK:** Black  
**NT:** Natural  
**RY:** Red/Yellow

## 2 AJUCH BELLS

**SIZES** 30" long  
**MABS:** Small bells  
**MABM:** Medium bells  
**MABL:** Large bells

**MATERIAL** Brass and synthetic wax

**FEATURES** Cast bells; Solid hook for easy attachment; Synthetic wax rope

**INCLUDES** Canvas pouch for safe and simple storage

**COLOURS** **MABS:** Brown and Turquoise  
**MABM:** Black  
**MABL:** Dark Red and Gold

## 3 KOKIRIKO

**MATERIAL** Wood

**FEATURES** Ergonomically shaped handle; Durable cord

**COLOUR** **AM:** Amber

## 4 WOODEN FROGS

**SIZES** **M:** Medium; **L:** Large

**FEATURE** Authentic "ribbit" sound

## 5 TRIANGLES

**SIZES** **TRI10B:** 4"  
**TRI15B:** 6"  
**TRI20B:** 8"

**MATERIAL** Solid brass

**INCLUDES** Wooden holder with braided nylon cord  
 Metal beater

## 6 THE NIGHT

**MATERIALS** Solid steel balls and cylinder  
 Wooden body

**FEATURES** Unique sound of crickets;  
 Ergonomically shaped handle

**COLOUR** **AM:** Amber

## 7 THE ROAR

**MATERIAL** Wood

**FEATURE** Rattling sustain

## 8 STAND ALONE BELL TREE

**MATERIAL** Solid brass bells

**FEATURE** Adjustable metal stand

**INCLUDES** Striker

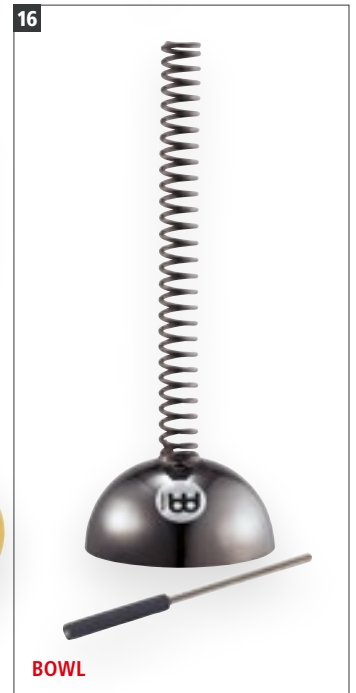
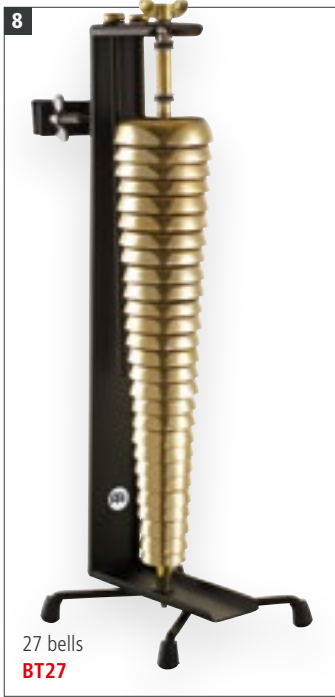

**9 HAND HELD BELL TREE**

**MATERIAL** Solid brass bells  
**INCLUDES** Striker

**10 HANGING FINGER CYMBALS**

**SIZES** 2 3/8" diameter  
**MATERIAL** Special bronze alloy  
**FEATURES** Shimmering sound; Durable cord

**11 PROFESSIONAL FINGER CYMBALS**

**SIZE** 2 5/8" diameter  
**MATERIAL** Special bronze alloy  
**FEATURES** Identical, high pitched sound; Durable cord

**12 ORIENTAL FINGER CYMBALS**

**SIZE** 2 3/8" diameter  
**MATERIAL** Special bronze alloy  
**FEATURES** Identical in pitch; Durable rubber band connection

**BILL SARAGOSA LINE 13 14 15 16**

**MATERIAL** Special steel alloy  
**FEATURE** Wide sound spectrum  
**FINISH** Black nickel

**13 LIQUID TRIANGLE**

**FEATURES** The triangle portion may be played in the classical manner, while the chamber creates eerie resonant overtones; Special steel alloy, filled with water  
**INCLUDES** Metal beater

**14 CONE-STACK**

**FEATURES** Fourchambered shaker with some wild characteristics; Get a kind of multi-chambered stereo effect; A set of two

**15 GALAXY**

**FEATURES** Two resonant liquid chambers are connected by a long steel spiral liquid inside

**INCLUDES** the two chambers exerts variable dampening on the thin steel resonator plates  
Metal beater

**16 HELIX BOWL**

**FEATURES** Wonderful instrument consisting of a steel helix welded to a resonating chamber; Deep resonating wah-wah effect  
**INCLUDES** Metal beater

**17 WAH-WAH TUBES**

**SIZE** Large (low pitch)  
**MATERIAL** Aluminum  
**INCLUDES** Rubber mallet  
**COLOUR** **BK:** Black

**18 RHYTHM BELL**

**SIZE** 8 1/2"  
**MATERIAL** Special cast alloy  
**FEATURES** Cutting bell sound; Very long sustain

# CHIMES

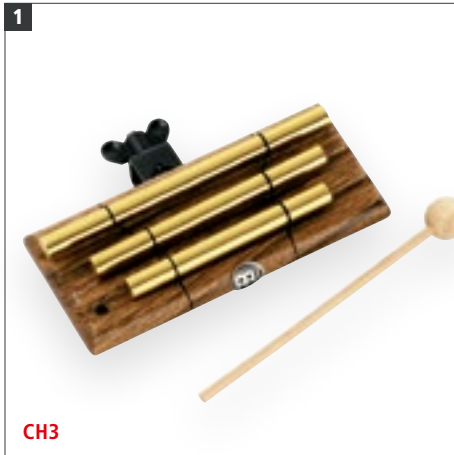

CH3



12 bars  
CH-H12

18 bars  
CH-H18

24 bars  
CH-H24



12 pegs  
CH-HPEG



27 bars, single row  
HCH1R



33 bars, single row  
HCH2BK



27 bars, single row  
CH27VWB



33 bars, single row  
CH33VWB

## 1 TRI TONE CHIMES

**MATERIAL** Gold anodized aluminum alloy  
**FEATURES** Three free-floating bars create a very long sustain  
 Tonally matched bars  
 Mountable on all common L-rods  
**INCLUDES** Wooden beater and holder

## 2 HAND CHIMES

**SIZES** **CH-H12:** 12 bars  
**CH-H18:** 18 bars  
**CH-H24:** 24 bars  
**MATERIAL** Gold anodized aluminum alloy  
**FEATURES** Can easily be played by hand  
 Produce a full and rich sound

## 3 PEG CHIMES

**SIZE** 12 pegs  
**MATERIAL** Gold plated steel  
**FEATURE** Perfect for special accents

## 4 HEADLINER® SERIES CHIMES, 27 BARS

**SIZE** 27 bars, single row  
**MATERIAL** Silver anodized aluminum alloy  
**FEATURES** Great and affordable addition to any percussion set-up  
 Produce a full and warm chime sound  
**COLOUR** **R:** Red

## 5 HEADLINER® SERIES CHIMES, 33 BARS

**SIZE** 33 bars, single row  
**MATERIAL** Silver anodized aluminum alloy  
**FEATURE** Generate a full sound spectrum  
**COLOUR** **BK:** Black

## 6 VINTAGE CHIMES, 27 BARS

**SIZE** 27 bars, single row  
**MATERIAL** Silver anodized aluminum alloy  
**FEATURE** Excellent addition to any drum or percussion arrangement  
**COLOUR** **VWB:** Vintage Wine Barrel

## 7 VINTAGE CHIMES, 33 BARS

**SIZE** 33 bars, single row  
**MATERIAL** Silver anodized aluminum alloy  
**FEATURES** Can be used in a wide range of musical styles  
 Producing a sweet sparkling sound  
**INCLUDES** Holder; Striker  
**COLOUR** **VWB:** Vintage Wine Barrel

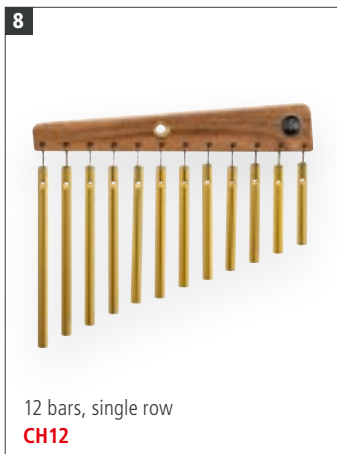

12 bars, single row  
**CH12**

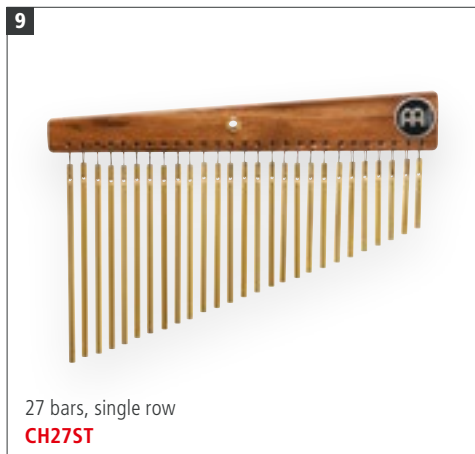

27 bars, single row  
**CH27ST**



27 bars, single row  
**CH27**



33 bars, single row  
**CH33HF**



66 bars, double row  
**CH66HF**

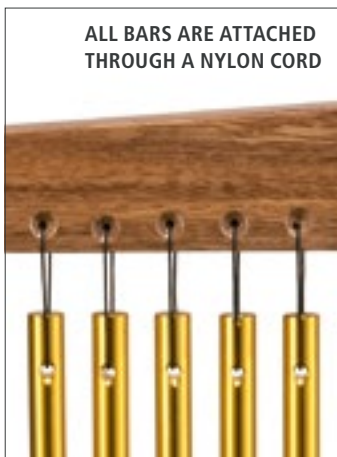

**ALL BARS ARE ATTACHED THROUGH A NYLON CORD**



60 bars, double row  
**LC60HF**



**EDWIN CLEMENTE, PUERTO RICO**

**8 CHIMES, 12 BARS**  
**SIZE** 12 bars, single row  
**MATERIAL** Gold anodized aluminum alloy  
**FEATURES** Produce a beautiful, high pitched sound  
 Ideal for tasteful chime accents

**9 STUDIO CHIMES, 27 BARS**  
**SIZE** 27 bars, single row  
**MATERIAL** Gold anodized aluminum alloy  
**FEATURE** Slightly thinner bars for a full, rich and delicate sound

**10 CHIMES, 27 BARS**  
**SIZE** 27 bars, single row  
**MATERIAL** Gold anodized aluminum alloy  
**FEATURES** Produce a full sound with a wide tonal spectrum  
 Ideal for smaller stages and club scenes

**11 CHIMES, 33 BARS**  
**SIZE** 33 bars, single row  
**MATERIAL** Gold anodized aluminum alloy  
**FEATURES** Produce a very bright sound with a pronounced upper overtone spectrum  
 Perfect for all live situations  
**INCLUDES** Holder; Striker

**12 CHIMES, 66 BARS**  
**SIZE** 66 bars, double row  
**MATERIAL** Gold anodized aluminum alloy  
**FEATURES** Produces a rich and full sound  
 Cut through any band setting  
**INCLUDES** Holder; Striker

**13 ARTIST SERIES CHIMES LUIS CONTE**  
**SIZE** 60 bars, double row  
**MATERIAL** Silver anodized aluminum alloy  
**FEATURES** Produces a bright sound from the medium and low pitched bars  
 Perfect for all studio situations  
**INCLUDES** Holder; Striker  
**COLOUR** Green

# FRAME DRUMS



## 1 HAND DRUMS

**SIZES** **HD10:** 10"; **HD12:** 12"; **HD14:** 14"; **HD16:** 16"; **HD18:** 18"; **HD20:** 20"; **HD22:** 22"

**MATERIALS** Siam Oak (*Hevea brasiliensis* Muell.-Arg.)  
**AB:** Hand selected goatskin head  
**AB-TF:** True Feel synthetic head

**COLOUR** African Brown

## 2 TARS

**SIZES** **FD16:** 16", 2 1/2" deep  
**FD18:** 18", 2 1/2" deep  
**FD20:** 20", 2 1/2" deep  
**FD22:** 22", 2 1/2" deep

**MATERIALS** Siam Oak (*Hevea brasiliensis* Muell.-Arg.)  
**T:** Hand selected goatskin head  
**T-TF:** True Feel synthetic head

**FEATURE** Internal tuning system

**INCLUDES** Hex key

**COLOUR** African Brown, matte

## 3 ARTISAN EDITION TARS (PATENTED)

**SIZES** **AE-FD14:** 14", 2 1/2" deep  
**AE-FD18:** 18", 2 1/2" deep  
**AE-FD22:** 22", 2 1/2" deep

**MATERIALS** Siam Oak (*Hevea brasiliensis* Muell.-Arg.)  
Hand selected goatskin head

**FEATURES** Special designed bearing edge (DE, US patent); Internal tuning system

**INCLUDES** Hex key

**COLOUR** Walnut Brown, matte

## 4 SEA DRUMS

**SIZES** **FD16:** 16", 2 3/4" deep  
**FD18:** 18", 2 3/4" deep  
**FD20:** 20", 2 3/4" deep  
**FD22:** 22", 2 3/4" deep

**MATERIALS** Siam Oak (*Hevea brasiliensis* Muell.-Arg.)  
Transparent synthetic head and  
**SD:** Hand selected goatskin head  
**SD-TF:** True Feel synthetic head

**FEATURES** Steel balls inside; Sealable filling port

**COLOUR** African Brown, matte

## 5 MIZHARS

**SIZES** **FD12:** 12", 4" deep; **FD14:** 14", 4" deep; **FD18:** 18", 4" deep

**MATERIALS** Siam Oak (*Hevea brasiliensis* Muell.-Arg.)  
**T-D:** Hand selected goatskin head  
**T-D-TF:** True Feel synthetic head

**FEATURES** Deep shell construction for full sound development; Internal tuning system

**INCLUDES** Hex key

**COLOUR** Brown Burl, matte

## 6 ARTISAN EDITION MIZHARS (PATENTED)

**SIZES** **AE-FD14:** 14", 4" deep  
**AE-FD18:** 18", 4" deep  
**AE-FD22:** 22", 4" deep

**MATERIALS** Siam Oak (*Hevea brasiliensis* Muell.-Arg.)  
Hand selected goatskin head

**5** **HAND SELECTED GOATSKIN HEAD**

18" x 4" **FD18T-D**  
14" x 4" **FD14T-D**  
12" x 4" **FD12T-D**

**TRUE FEEL SYNTHETIC HEADS**

18" x 4" **FD18T-D-TF**  
14" x 4" **FD14T-D-TF**  
12" x 4" **FD12T-D-TF**

**6**

22" x 4" **AE-FD22T-D**  
18" x 4" **AE-FD18T-D**  
14" x 4" **AE-FD14T-D**

**7** **HAND SELECTED GOATSKIN HEAD**

16" x 2 1/2" **FD16BE**  
14" x 4" **FD14BE**  
12" x 4" **FD12BE**

**TRUE FEEL SYNTHETIC HEADS**

16" x 2 1/2" **FD16BE-TF**  
14" x 4" **FD14BE-TF**  
12" x 4" **FD12BE-TF**

**8** **METAL RINGS FOR SPECIAL EFFECTS**

20" x 2 1/2" **FD20D-TF**  
20" x 2 1/2" **FD20D-WH**

**9** **CROSS BAR**

18" x 4" **FD18BO**

**10** **DAMPENING LAYER FOR LESS OVERTONES**

14" x 6" **FD14IBO**

**11**

7 1/2" **FD7KA**

**13**

Set, 4 pcs. **PL-SET**

**12**

15" **HOD15**  
12 1/2" **HOD125**

**FEATURES** Special designed bearing edge (DE, US patent); Internal tuning system  
**INCLUDES** Hex key  
**COLOUR** Walnut Brown, matte

**7 BENDIRS**

**SIZES** **FD12:** 12", 4" deep; **FD14:** 14", 4" deep; **FD18:** 16", 2 1/2" deep  
**MATERIALS** Siam Oak (*Hevea brasiliensis* Muell.-Arg.)  
**BE:** Hand selected goatskin head  
**BE-TF:** True Feel synthetic head  
**FEATURES** Internal tuning system; Buzzing effect  
**INCLUDES** Hex key  
**COLOUR** African Brown, matte

**8 DAFS**

**SIZE** 20", 2 1/2" deep  
**MATERIALS** Siam Oak (*Hevea brasiliensis* Muell.-Arg.)  
**FD20D-TF:** True Feel synthetic head  
**FD20D-WH:** Woven synthetic head

**FEATURE** Metal rings for special effects  
**COLOUR** African Brown, matte

**BODHRANS 9 10**

**MATERIALS** Siam Oak (*Hevea brasiliensis* Muell.-Arg.)  
Hand selected goatskin head  
**INCLUDES** Hex key

**9 CELTIC BODHRAN**

**SIZE** 18", 4" deep  
**FEATURES** Cross bar; Internal tuning system  
**COLOUR** African Brown, matte

**10 IRISH BODHRAN**

**SIZE** 14", 6" deep  
**FEATURES** Extra deep shell for full sound development; Dampening layer around rim for reduced overtones  
**COLOUR** Brown Burl, matte

**11 KANJIRA**

**SIZE** 7 1/2", 2 1/4" deep  
**MATERIALS** Siam Oak (*Hevea brasiliensis* Muell.-Arg.)  
Hand selected goatskin head  
**FEATURES** Many sound options; Set of 3 jingles  
**INCLUDES** Hex key  
**COLOUR** African Brown, matte

**12 NATIVE AMERICAN-STYLE HOOP DRUMS**

**SIZES** **HOD125:** 12 1/2"; **HOD15:** 15"  
**MATERIALS** Hand selected buffalo head  
Nylon lacing and grip  
**FEATURE** Warm and powerful sound  
**INCLUDES** Leather padded wooden beater

**13 PLENERA SET**

**SIZES** 8" Quinto; 10" Seguidor; 12" Tumbador  
**MATERIALS** ABS Plastic frames; Goatskin heads  
**FEATURE** External mechanical lug tuning  
**INCLUDES** Nylon Bag; Tuning Key

# MINI & STANDARD DARBUKAS



## 1 MINI DARBUKAS

**SIZE** 4 1/4" diameter, 7 3/4" tall  
**MATERIALS** Aluminum shell  
 All-weather synthetic head  
**FEATURES** Fun to play and easy to carry  
 Great gift idea  
**HE-050:** Plain shell  
**HE-051:** Hand hammered shell  
**HE-052:** Hand engraved shell  
**HE-053:** Lacquered shell  
**INCLUDES** Tuning key

## 2 COPPER DARBUKAS, HAND ENGRAVED

**SIZES** **HE-204:** 7 1/2" diameter, 14 3/4" tall  
**HE-205:** 7 7/8" diameter, 15 1/2" tall  
**MATERIALS** Copper shell  
 Natural rawhide  
**FEATURE** Hand engraved shell  
**INCLUDES** Tuning key

## 3 COPPER DARBUKAS, BRASS PLATED, HAND HAMMERED

**SIZES** **HE-214:** 7 1/2" diameter, 14 3/4" tall  
**HE-215:** 7 7/8" diameter, 15 1/2" tall  
**MATERIALS** Copper shell  
 Synthetic head  
**FEATURE** Hand hammered shell  
**INCLUDES** Tuning key

## 4 ALUMINUM DARBUKAS, HAND ENGRAVED

**SIZES** **HE-122:** 6 1/2" diameter, 12 3/4" tall  
**HE-124:** 8" diameter, 14 1/2" tall  
**MATERIALS** Aluminum shell  
 Synthetic head  
**FEATURE** Hand engraved shell  
**INCLUDES** Tuning key

## 5 ALUMINUM JINGLE DARBUKAS, HAND HAMMERED

**SIZES** **HE-314:** 8" diameter, 14 1/2" tall  
**HE-315:** 8 1/4" diameter, 16" tall  
**MATERIALS** Aluminum shell  
 Synthetic head  
**FEATURES** Built-in jingles  
 Hand hammered shell  
**INCLUDES** Tuning key

## 6 ALUMINUM DARBUKAS, HAND HAMMERED

**SIZES** **HE-110:** 5 1/3" diameter, 9 1/4" tall  
**HE-111:** 5 7/8" diameter, 11" tall  
**HE-112:** 6 1/2" diameter, 12 3/4" tall  
**HE-113:** 7 1/4" diameter, 13 1/3" tall  
**HE-114:** 8" diameter, 14 1/2" tall  
**MATERIALS** Aluminum shell  
 Synthetic head  
**FEATURE** Hand hammered shell  
**INCLUDES** Tuning key



# MINI & STANDARD DOUMBEKS



DARBUKAS & DOUMBEKS



## 7 ALUMINUM DARBUKAS, PLAIN

**SIZES** HE-100: 5 1/3" diameter, 9 1/4" tall  
 HE-101: 5 7/8" diameter, 11" tall  
 HE-102: 6 1/2" diameter, 12 3/4" tall  
 HE-103: 7 1/4" diameter, 13 1/3" tall  
 HE-104: 8" diameter, 14 1/2" tall

**MATERIALS** Aluminum shell  
 Synthetic head

**INCLUDES** Tuning key

## 8 MINI DOUMBEKS

**SIZE** 4" diameter, 7 1/2" tall

**MATERIALS** Aluminum shell  
 Synthetic head

**FEATURES** Deep lows with snappy, ringing highs  
 HE-1018: Hand engraved shell  
 HE-1030: Hand hammered shell

**INCLUDES** Tuning key

## 9 COPPER DOUMBEK, HAND ENGRAVED

**SIZE** 8 1/2" diameter, 17 1/8" tall

**MATERIALS** Copper shell  
 Synthetic head

**FEATURE** Hand engraved shell

**INCLUDES** Tuning key

## 10 ALUMINUM DOUMBEKS, HAND ENGRAVED

**SIZES** HE-2018: 6" diameter, 12" tall (Soprano)  
 HE-3018, HE-3039: 8 1/2" diameter, 17 1/8" tall  
 HE-3218: 10" diameter, 18 1/4" tall (Bass)

**MATERIALS** Aluminum shell  
 Synthetic head

**FEATURES** Hand engraved shell  
 HE-2018: High pitched articulate sounds  
 HE-3039: Painted floral design  
 HE-3218: Super deep tones

**INCLUDES** Tuning key

## 11 ALUMINUM DOUMBEK, HAND HAMMERED

**SIZE** 8 1/2" diameter, 17 1/8" tall

**MATERIALS** Aluminum shell  
 Synthetic head

**FEATURE** Hand hammered shell

**INCLUDES** Tuning key

## 12 ALUMINUM DOUMBEKS

**SIZES** HE-2000: 6" diameter, 12" tall (Soprano)  
 HE-3000: 8 1/2" diameter, 17 1/8" tall  
 HE-3200: 10" diameter, 18 1/4" tall (Bass)

**MATERIALS** Aluminum shell (leatherette covered)  
 Synthetic head

**FEATURES** HE-2000: High pitched articulate sounds  
 HE-3200: Super deep tones

**INCLUDES** Tuning key

**COLOUR** Black

# RITUAL DRUMS

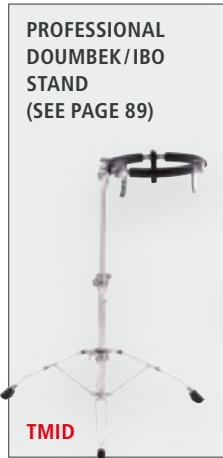
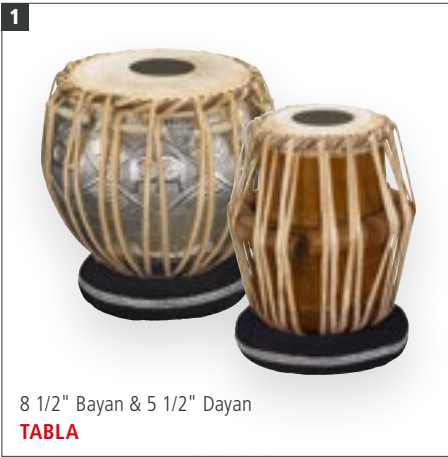

## 1 TABLA SET

- SIZES** 5 1/2" Dayan  
8 1/2" Bayan
- MATERIALS** Chrome plated copper with goatskin head  
Mahogany with goatskin head
- FEATURES** Authentic tabla heads  
Nylon straps for longer durability
- INCLUDES** Padded support rings; Tuning hammer

## 2 ARTISAN EDITION TABLA SET

- SIZES** 5 1/2" Dayan  
9" Bayan
- MATERIALS** Copper with goatskin head  
Mahogany with goatskin head
- FEATURES** Top quality goatskin tabla heads  
Traditional tuning system with rawhide thongs
- INCLUDES** Tuning hammer and wooden tuning dowel; Ring pads; Protective head covers

## 3 QUINTO IBO DRUM

- SIZE** Small
- MATERIAL** Ceramic
- FEATURES** Full and rich sounds  
Built-in microphone hole
- COLOUR** **WH:** White

## 4 FIBREGLASS TRI SOUND IBO DRUMS

- SIZE** Large
- MATERIAL** Premium fibreglass
- FEATURES** Built-in microphone hole  
Resistant shell construction  
**ID3GO:** Rawhide playing surface  
**ID4BKO:** Extra fibreglass playing surface
- INCLUDES** Foam padded base
- COLOUR** **BKO:** Black Ornament  
**GO:** Gold Ornament

## 5 CERAMIC IBO DRUM

- SIZE** Large
- MATERIAL** Ceramic
- FEATURES** Full and rich sounds  
Built-in microphone hole
- INCLUDES** Foam padded base
- COLOUR** **RB:** Red/Brown

## 6 FIBREGLASS LIQUID IBO DRUM

- SIZE** Large
- MATERIAL** Premium fibreglass
- FEATURES** Special bottom, filled with water  
Built-in microphone hole  
Resistant shell construction
- INCLUDES** Foam padded base
- COLOUR** **BK/WH:** Black/White



6 3/4" & 12" lya **BA3BK**    5 3/4" & 8 3/4" ltotele **BA2BK**    5 1/4" & 8" Okonkolo **BA1BK**



8" x 16" **ATD-L**    7" x 12" **ATD-M**

COMES WITH A CURVED WOODEN BEATER



ALEX PERTOUT, AUSTRALIA



**9** TRUE SKIN BUFFALO HEADS  
11" **MTA1SNT-M**



**10** HEAVY-DUTY STAND CAN BE TILTED  
8" & 9" **HCG89NT**



**11** **SH-R**    **SHR-BR**



**12** **BE1R**

NEARLY UNBREAKABLE

**7** **BATAS**

**SIZES** **BA1:** 5 1/4" & 8" Okonkolo  
**BA2:** 5 3/4" & 8 3/4" ltotele  
**BA3:** 6 3/4" & 12" lya  
**MATERIALS** Premium fiberglass  
Hand selected buffalo heads  
**FEATURE** Traditional TTR-Rims  
**INCLUDES** Nylon strap; Tuning key  
**COLOUR** **BK:** Black

**8** **AFRICAN WOOD TALKING DRUMS**

**SIZES** **M:** 7" diameter, 12" tall  
**L:** 8" diameter, 16" tall  
**PP ROPES** **M:** 3 mm thickness, 23 runners  
**L:** 3 mm thickness, 28 runners  
**MATERIALS** Mahogany Wood (*Swietenia macrophylla*)  
Hand selected goatskin heads  
**FEATURE** Nylon tuning strap  
**INCLUDES** Curved wooden beater  
**FINISH** Brown/Black

**9** **TAMBORA**

**SIZE** 11"  
**MATERIALS** Siam Oak (*Hevea brasiliensis* Muell.-Arg.)  
True Skin Buffalo Heads  
**FEATURE** Black powder coated hardware  
**INCLUDES** Nylon strap; Wooden beaters; Tuning key  
**COLOUR** **SNT-M:** Super Natural  
**FINISH** Matte

**10** **WOOD CONGUITAS**

**SIZES** 8" & 9"  
**MATERIALS** Siam Oak (*Hevea brasiliensis* Muell.-Arg.)  
Hand selected buffalo heads  
**FEATURES** 8 mm strong tuning lugs; Original MEINL style tuning brackets; Traditional rims; Black powder coated hardware  
**INCLUDES** Height adjustable tilting double braced tripod stand; Tuning key; Wrench  
**COLOUR** **NT:** Natural  
**FINISH** High gloss

**11** **SHEKERES**

**SIZES** **SH-R:** Medium  
**SHR-BR:** Medium  
**MATERIAL** Premium fiberglass  
**COLOURS** **BR:** Brown  
**R:** Red

**12** **BERIMBAU**

**MATERIAL** Premium fiberglass  
**INCLUDES** Small Caxixi; Metal plate; Wooden stick; Carrying bag  
**COLOUR** **R:** Red

# DIDGERIDOOS

**1** COLOURFUL HAND-PAINTED ACCENTS HARKEN TO TRADITIONAL NATIVE AUSTRALIAN DESIGNS



47" **DDG1-BK**      47" **DDG1-BR**      47" **DDG1-R**

**2** **NEW**



51" **SDDG1-BA**      51" **SDDG1-BK**      S-Shape, 51" **SDDG2-BK**

**3** TWO TELESCOPING SECTIONS



36"-62" **TSDDG1-BK**

## 1 WOOD DIDGERIDOOS

**SIZE** 47" long  
**MATERIAL** Bamboo  
**TUNING** **DDG1-BK:** E  
**DDG1-BR:** D#  
**DDG1-R:** E  
**COLOURS** **BK:** Black  
**BR:** Brown  
**R:** Red

## 2 SYNTHETIC DIDGERIDOOS

**SIZE** 51" long  
**MATERIAL** Lightweight synthetic  
**TUNING** **SDDG1-BA:** D  
**SDDG1-BK:** D  
**SDDG2-BK:** C#  
**FEATURES** **SDDG2-BK**  
 "S" shaped body for bigger sounds  
 Distinctive, full drone and harmonic overtones  
**COLOURS** **BA:** Bamboo  
**BK:** Black

## 3 TROMBONE DIDGERIDOO

**SIZE** 36"-62" long  
**MATERIAL** Premium fiberglass  
**TUNING** from: G# G F# F E D# D C# C  
**FEATURE** Two telescoping sections for variable pitch  
**COLOUR** **BK:** Black



60"  
**TSDDG2-BK**



57"  
**PROFDDG1-BK**



57"  
**PROSDDG1-BK**



61"  
**SDDG1-SI**



8 1/2" x 5"  
**DDG-BOX**

SMALL IN SIZE BUT BIG IN SOUND



**DDG-MP**



**4 SYNTHETIC SLIDE TRAVEL DIDGERIDOO**

**SIZE** Portable: 24" long; playable: 60" long  
**MATERIAL** Lightweight synthetic  
**TUNING** D  
**FEATURES** Contractible body for easy travel  
 Distinctive, full drone and harmonic overtones  
**INCLUDES** Bag  
**COLOUR** **BK:** Black

**5 PRO FIBERGLASS DIDGERIDOO**

**SIZE** 57" long  
**MATERIAL** Premium fiberglass  
**TUNING** D  
**COLOUR** **BK:** Black

**6 PRO SYNTHETIC DIDGERIDOO**

**SIZE** 57" long  
**MATERIAL** Lightweight synthetic  
**TUNING** D  
**COLOUR** **BK:** Black

**7 ARTIST SERIES DIDGERIDOO  
SIMON "SI" MULLUMBY**

**SIZE** 61" long  
**MATERIAL** Premium fiberglass  
**TUNING** F  
**COLOUR** Grey

**8 TRAVEL DIDGERIDOO (US PATENT)**

**SIZE** 8 1/2" x 5"  
**MATERIAL** Mahogany Wood (*Swietenia macrophylla*)  
**TUNING** C  
**FEATURES** Heat-branded logo  
 Compact size

**9 DIDGERIDOO MOUTHPIECE**

**SIZE** Inner diameter: 30 mm  
 Outer diameter: 60 mm  
**MATERIAL** Antiseptic beeswax  
**FEATURES** Easy mountable  
 100% pure beeswax  
 Fits perfect on our didgeridoos

# RAINMAKER & RAINSTICKS



**1 PRO RAINMAKER**  
 SIZE 3 3/4" W x 25 1/4" H x 3 3/4" D  
 MATERIAL Baltic Birch (*Betula pendula*)  
 FEATURES Ultra long sustain  
 Authentic rain sound  
 Natural birch wood construction  
 COLOUR **NT**: Natural

**2 WOOD RAINSTICKS**  
 SIZES **S**: 16"  
**M**: 24"  
**M/L**: 31 1/2"  
**L**: 39"  
**XL**: 47"  
**XXL**: 60"  
 MATERIAL Bamboo  
 COLOURS **BK**: Black  
**R**: Red

**3 SYNTHETIC RAINSTICKS**  
 SIZE **L**: 39"  
 MATERIAL Lightweight synthetic  
 COLOURS **BA**: Bamboo  
**R**: Red

**4 PRO RAINSTICK**  
 SIZE **XL**: 47"  
 MATERIAL Rattan wrapped Bamboo  
 FEATURES Long susurraton  
 Authentic rain sounds

# PERCUSSION CYMBALS



RAINSTICKS & CYMBALS

**1**



10" Splash  
**CA10S**

**2**



10" Hi-hat  
**CA10PH**

**3**



14" Crash  
**CA14C**

**4**



18" Timbales Crash-Ride  
**CA18CR**

**5** BUILT-IN JINGLES



14" Jingle Bell  
**CA14PJB**

**6**



16" Crash  
**CA16C**

**6**



Magnetic Sustain Control  
**MCT**

BASED ON BENNY GREB'S IDEA

**7**



Drum Honey  
**MDH**

Drum Honey Fishbowl  
**VE16-MDH**

Drum Honey Refill Pack  
**VE6-MDH**

**1 PERCUSSION SPLASH**

**SIZE** 10"  
**MATERIAL** B20 Bronze  
**FEATURES** Hand-hammered  
Brilliant finish  
Fast response and attack  
Quick decay

**2 PERCUSSION HIHAT**

**SIZE** 10"  
**MATERIAL** B20 Bronze  
**FEATURES** Can be played by hand or with lighter sticks  
Recommended for use with the MEINL Low Hat

**3 PERCUSSION CRASHES**

**SIZES** **CA14C:** 14"  
**CA16C:** 16"  
**MATERIAL** B20 Bronze

**FEATURES** Hand-hammered  
Brilliant finish  
Fast response and attack  
Quick decay

**4 TIMBALES CRASH-RIDE**

**SIZE** 18"  
**MATERIAL** B20 Bronze  
**FEATURES** Hand-hammered  
Brilliant finish  
Cutting bell sound  
Great crash sound

**5 PERCUSSION JINGLE BELL**

**SIZE** 14"  
**MATERIAL** B8 Bronze  
**FEATURES** Precisely hammered  
Built-in jingles

**6 MAGNETIC SUSTAIN CONTROL**

**CONTAINS** 2 x Light dampening magnets (16 x 4 mm)  
2 x Heavy dampening magnets (16 x 9 mm)  
**FEATURES** Easily control the sustain and dampen the tone of your cymbals, cowbell, or other instruments  
Simply adjust the effect by positioning the magnets on your instrument  
**INCLUDES** Storage container

**7 DRUM HONEY**

**CONTAINS** **MDH:** 1 pack of Drum Honey (6 pcs.)  
**VE16-MDH:** 16 packs of Drum Honey  
**VE6-MDH:** 6 packs of Drum Honey  
**FEATURES** Transforms your drum sound into a warm and sweet tone with no effort  
The gels can be removed and reused as needed  
Washable and non-toxic  
**INCLUDES** **VE16-MDH:** Fishbowl

# STICKS, BEATERS, BRUSHES, MALLETS & SCRAPERS

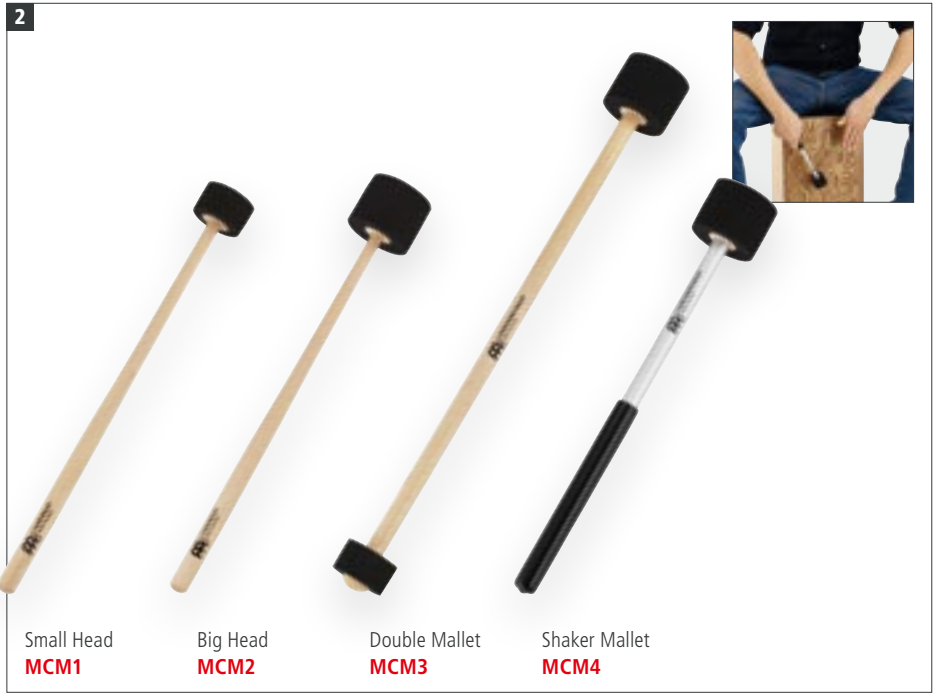

## 1 BASS BEAT CAJON BRUSH

**SIZE** 13" long  
**MATERIALS** Polymer bristles  
Foam rubber  
**FEATURES** Straight polymer bristles for ultra-smooth precision; Soft foam rubber for full-bodied low notes; Two adjustable control rings; Flexible handle

## 2 CAJON MALLET COLLECTION

**SIZES** **MCM1, MCM4:** 11 3/4" long  
**MCM2:** 12 1/4" long  
**MCM3:** 15 1/2" long  
**MATERIALS** Foam rubber  
**MCM1, MCM2, MCM3:** Hard maple  
**MCM4:** Aluminum  
**FEATURES** Made in Germany  
**MCM1:** Made out of the finest hand-selected maple; Small foam rubber head; Designed for softer playing  
**MCM2:** Made out of the finest hand-selected maple; Extra thick foam rubber head  
**MCM3:** Made out of the finest hand-selected maple; Foam rubber padding; Two different ends for contrasting sounds  
**MCM4:** Integrated shaker effect in handle; Soft foam rubber head; Lightweight aluminum handle

## 3 TAMBORIM STICKS

**MATERIAL** Plastic  
**COLOURS** **BK:** Black  
**R:** Red

## 4 BODHRAN TIPPERS

**MATERIAL** Ash Wood  
**COLOUR** African Brown

## 5 SAMBA STICKS

**SIZES** **SST1-S:** Stick, short version  
**SST1-R:** Stick, medium version  
**SST1-L:** Stick, long version  
**SST3-S:** Triple stick, short version  
**SST3:** Triple stick  
**SST7:** Sevenfold stick  
**MATERIAL** Plastic



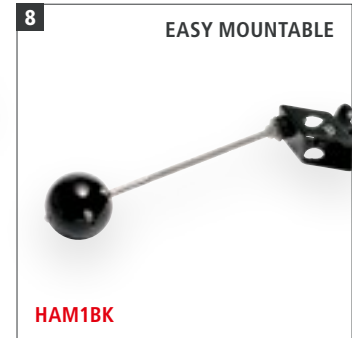
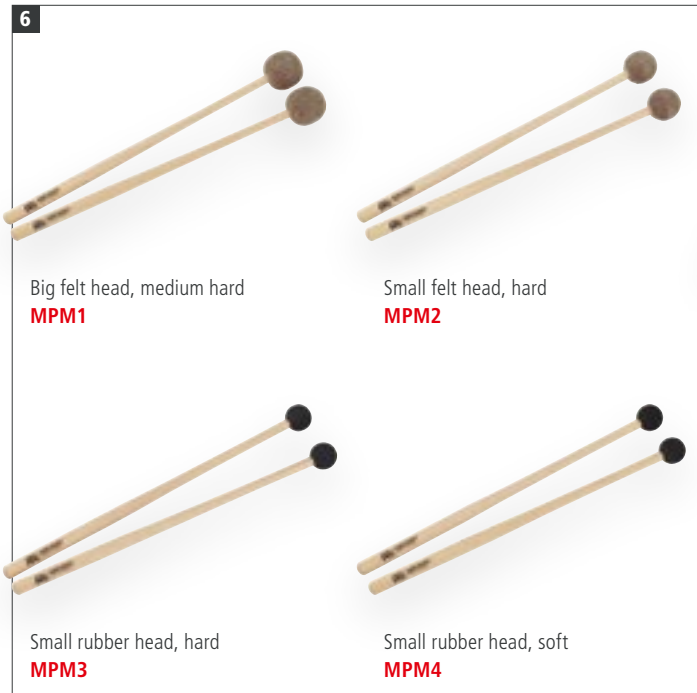

**6 PERCUSSION MALLETS**  
 SIZE 12 1/2" long  
 MATERIALS Hard maple  
**MPM1:** Big felt head, medium hard  
**MPM2:** Small felt head, hard  
**MPM3:** Small rubber head, hard  
**MPM4:** Small rubber head, soft  
 FEATURES Made out of the finest hand-selected maple; Great for woodblocks and plastic percussion blocks; Made in Germany

**7 COWBELL BEATERS**  
 MATERIALS **COW1, COW2:** Siam Oak (*Hevea brasiliensis* Muell.-Arg.)  
**COW3:** ABS plastic  
 FEATURES Ribbed grip; Durable construction

**8 HANDMATE**  
 MATERIAL Steel construction with a wooden ball  
 FEATURE Fully adjustable

**9 SURDO BEATER HOLDER**  
 MATERIAL Leather  
 COLOUR Black

**10 SAMBA BEATERS**  
 SIZES **SB1:** 15" long  
**SB2, SB3, SB4, SB5, SB6:** 16" long  
 MATERIALS **SB1:** Aluminum stick with 2" felt beater  
**SB2:** Wood stick with 2" felt beater  
**SB3:** Wood stick with 2 1/2" felt beater  
**SB4:** Wood stick with 2" leather beater  
**SB5:** Wood stick with 3" bushy felt beater  
**SB6:** Wood stick

**11 TALKING DRUM BEATER**  
 MATERIAL Mahogany Wood

**12 GÜIRA SCRAPERS**  
 MATERIALS Steel rods  
**MGS1:** Ergonomic wooden grip  
**MGS2:** Sanded ABS grip

# STANDS

1



Black powder coated



Chrome plated



Gold tone

## Black powder coated

For Marathon® Classic Series  
For Marathon® Designer Series  
For Luis Conte Artist Series

**ST-MCC11BK:** 11"  
**ST-MCC1134BK:** 11 3/4"  
**ST-MCC1212BK:** 12 1/2"

## Chrome plated

For Marathon® Exclusive Series  
**ST-MEC11CH:** 11"  
**ST-MEC1134CH:** 11 3/4"  
**ST-MEC1212CH:** 12 1/2"

For Professional Series  
For Fibercraft Series  
**ST-MP11CH:** 11"  
**ST-MP1134CH:** 11 3/4"  
**ST-MP1212CH:** 12 1/2"

For Floatune Series  
**ST-FL10CH:** 10"  
**ST-FL11CH:** 11"  
**ST-FL12CH:** 12"  
**ST-FL13CH:** 13"

For Woodcraft Series  
**ST-WC11CH:** 11"  
**ST-WC1134CH:** 11 3/4"  
**ST-WC1212CH:** 12 1/2"

## Gold tone

For Marathon® Exclusive Series  
**ST-MEC11G:** 11"  
**ST-MEC1134G:** 11 3/4"  
**ST-MEC1212G:** 12 1/2"

For Mongo Santamaria Artist Series  
**ST-MSA11G:** 11"  
**ST-MSA1134G:** 11 3/4"  
**ST-MSA1212G:** 12 1/2"

**QUICK AND EASY HEIGHT  
ADJUSTABILITY (DE PATENT)**

2

## EASY HEIGHT EXTENSION

Black powder coated  
**ST-HEBK**

Chrome plated  
**ST-HECH**

Gold tone  
**ST-HEG**



3



MIN. 43"  
MAX. 52 3/4"

For Headliner® congas  
**HDSTAND**

For MCC congas  
**TMDS**

4



For HDSTAND and TMDS  
**THBM**

**EASY  
MOUNTABLE**

6



Chrome plated  
**MCH-CH**

Gold tone  
**MCH-G**

**FOR ANY CONGA**

5



Chrome plated  
**TMPDS**

## 1 STEELY II CONGA STANDS (PATENTED)

**MATERIAL** Steel  
**FEATURES** Metal spike attachment on each leg  
L-shaped legs (DE, TH, US patent)  
U-shaped notch for quick set up and breakdown (US patent)  
Ergonomic arched rubber bracing for more stability (CN, DE, TH, US patent)  
Notches for quick height adjustability (DE patent)  
**INCLUDES** Hex key

## 2 STEELY II CONGA STAND HEIGHT EXPANDER SETS (DE PATENT)

**MATERIAL** Steel  
**FEATURE** Easy and effective height extension  
**INCLUDES** Mounting screws; Hex key  
**FINISHES** **BK:** Black powder coated  
**CH:** Chrome plated  
**G:** Gold tone

## 3 CONGA DOUBLE STANDS

**MATERIAL** Steel  
**FEATURES** Height adjustable  
Double braced tripod legs  
**INCLUDES** Hex key  
Memory locks  
Brackets  
Set of screws, nuts, and washers  
Mounting instructions

## 4 BONGO MOUNT

**MATERIAL** Chrome plated steel  
**FEATURES** Easy mountable on our conga double stands HDSTAND and TMDS  
Holds your bongo in place  
Adjustable angle

## 5 PROFESSIONAL CONGA DOUBLE STAND WITH WHEELS

**MATERIAL** Chrome plated steel  
**FEATURES** Height adjustable  
Heavy construction  
Double braced tripod legs  
Lockable high-quality wheels  
Padded separators for adjustable angle  
Mounting instructions  
**INCLUDES** Two mounting brackets

## 6 CONGA HANDLES

**MATERIAL** Steel  
**FEATURES** Simple and safe add-on to help transport congas  
Easily mountable with instructional guide  
Fits any common conga  
Leaves sound unaffected  
**INCLUDES** Mounting screws and washers  
Mounting instructions

**7** **STURDY LOCKABLE WHEELS MAKE IT EASY TO MOVE THE STAND INTO POSITION**

Chrome plated  
**TMPC**

**8** **THE LIGHTWEIGHT STAND CAN BE FOLDED TO A COMPACT UNIT WHICH REQUIRES LITTLE SPACE**

Chrome plated  
**TMC-CH**

**COMPATIBLE FOR ALL SIZES!**

**9**

MIN. 34 1/2"  
MAX. 50"

Black powder coated  
**THBS-BK**

Chrome plated  
**THBS**

**AN INNOVATIVE BRACKET DESIGN ENABLES QUICK SET UP (PATENTED)**

**10** **PADDED T-SHAPED TUBE FOR MORE STABILITY**

MIN. 31 1/2"  
MAX. 52 3/4"

Chrome plated  
**TMB**

**11** **A STABLE METAL CLAMP HOLDS THE ENTIRE UNIT IN PLACE**

MIN. 12 1/4"  
MAX. 20"

Chrome plated  
**TMB-S**

**LOW HEIGHT FOR SEATED PLAYERS**

**12** **PERFECT HEIGHT FOR CAJON PLAYERS**

MIN. 22 3/4"  
MAX. 29 1/2"

Black powder coated  
**THBS-S-BK**

**FINISHES** **CH:** Chrome plated  
**G:** Gold tone

**7 PROFESSIONAL CONGA STAND WITH WHEELS**  
**MATERIAL** Chrome plated steel  
**FEATURES** Adjustable padded stops fit any conga size  
 Height adjustable legs  
 Lockable wheels

**8 PROFESSIONAL CONGA STAND**  
**MATERIAL** Chrome plated steel  
**FEATURES** Unique design (DE patent)  
 Rubber padded crossbeams  
 Fully height adjustable  
 Folds up to a compact unit  
**INCLUDES** Hex key  
 Memory locks

**9 HEADLINER® SERIES BONGO STANDS (CN, DE, US PATENT)**  
**MATERIAL** Steel  
**FEATURES** Quick set up  
 Easy handling  
 Reliable placement  
 Double braced tripod stand  
 Fits all common bongos  
**INCLUDES** Wrench  
**FINISHES** **THBS:** Chrome plated  
**THBS-BK:** Black powder coated

**10 PROFESSIONAL BONGO STAND**  
**MATERIAL** Chrome plated steel  
**FEATURES** Padded T-shaped tube  
 Fully height and angle adjustable  
 Double braced tripod legs  
 Fits all common bongos  
**INCLUDES** Hex key  
 Memory locks

**11 PROFESSIONAL BONGO STAND FOR SEATED PLAYERS**  
**MATERIAL** Chrome plated steel  
**FEATURES** Seated playing position possible  
 Padded T-shaped tube  
 Fully height and angle adjustable  
 Double braced tripod legs  
 Fits all common bongos  
**INCLUDES** Hex key  
 Memory lock

**12 CAJON HEIGHT BONGO STAND**  
**MATERIAL** Black powder coated steel  
**FEATURES** Quick set up  
 Easy handling  
 Perfect height for cajon players  
 Fits all common bongos

# STANDS

## 1 COLLAPSIBLE DESIGN



Black powder coated  
**STDJST-BK**

## 2 QUICK AND EASY HEIGHT ADJUSTABILITY (DE PATENT)



Chrome plated  
**ST-DJEMBE**

## 3 LENGTH ADJUSTABLE FOR VARIOUS DJEMBE SIZES



MIN. 23 1/2"  
MAX. 37 3/4"

Chrome plated  
**TMD**

## 4 FITS ALL CAJON SIZES



MIN. 26"  
MAX. 40 1/2"

Black powder coated  
**TMCAJ**

## CAJON MICROPHONE STAND (SEE PAGE 05)



**CMS**

## CAJON DRUM SET STANDS (SEE PAGE 14)



MIN. 27"  
MAX. 42"

**CHS**

MIN. 25"  
MAX. 45"

**CCS**

MIN. 22"  
MAX. 37"

**CAS**

## 5 NEW



MIN. 22"  
MAX. 37"

Black powder coated  
**CPTS**

### 1 TRAVEL DJEMBE STAND

**MATERIAL** Black powder coated steel  
**FEATURES** Collapsible design  
Lightweight construction

### 2 STEELY II DJEMBE STAND (PATENTED)

**MATERIAL** Chrome plated steel  
**FEATURES** Metal spike attached to each leg  
L-shaped legs (DE, TH, US patent)  
U-shaped notch for quick set up and breakdown (US patent)  
Ergonomic arched rubber bracing for more stability (CN, DE, US patent)  
Notches for quick height adjustability (DE patent)  
Adapts to different djembe sizes

**INCLUDES** Hex key, 3 spacers

### 3 PROFESSIONAL DJEMBE STAND

**MATERIAL** Chrome plated steel  
**FEATURES** Rubber padded hooks  
Fully height and angle adjustable  
Double braced tripod legs

**INCLUDES** Hex key  
Memory lock

### 4 PROFESSIONAL CAJON STAND

**MATERIAL** Steel  
**FEATURES** Quick set up  
Fully height and angle adjustable  
Double braced tripod stand  
Fits all cajon sizes

### 5 CAJON PICKUP TAPS STAND

**MATERIAL** Black powder coated aluminum  
**FEATURES** Designed to mount the MEINL Cajon Pickup Tom and Snare Taps  
Low-key stage footprint  
L-Shaped 3/8" rod  
Foldable legs, height adjustable

### 6 LOW HAT

**MATERIAL** Chrome plated steel  
**FEATURES** Special low height  
Made just for cajon players

**6 SPECIAL LOW HEIGHT**



MIN. 29 1/2"  
MAX. 38"

Chrome plated  
**MLH**

**7**



MIN. 34"  
MAX. 57"

Chrome plated  
**TMT**

**8**



MIN. 34"  
MAX. 57"

Chrome plated  
**TMPT**

**9 THREE-ARM BASKET HOLDS THE HAND-BALE SECURELY**



Chrome plated  
**TMTS**

**10** **NEW**



Black powder coated  
**DDG-STAND**

**11**



MIN. 30 3/4"  
MAX. 67"

Chrome plated  
**TMCH**

**12**



MIN. 31 3/4"  
MAX. 50 3/4"

Chrome plated  
**TMID**

**13** **DIFFERENT RODS FOR ALL NEEDS**



MIN. 31 1/2"  
MAX. 52 1/2"

Chrome plated  
**TMPS**

**7 TIMBALE STAND**

- MATERIAL** Chrome plated steel
- FEATURES** Double braced tripod base  
Height and angle adjustable  
Standard mounting rod for auxiliary percussion
- INCLUDES** Accessory pouch  
L-shaped tuning key  
Tune Up Oil

**8 PROFESSIONAL TIMBALE STAND**

- MATERIAL** Chrome plated steel
- FEATURES** Heavy-duty double braced tripod base  
Height and angle adjustable  
Standard mounting rod for auxiliary percussion
- INCLUDES** Accessory pouch  
L-shaped tuning key  
Tune Up Oil

**9 HAND-BALE STAND**

- MATERIAL** Chrome plated steel
- FEATURES** Quick set up  
Rubber-tipped three arm basket  
Easy handling  
Double braced tripod stand

**10 DIDGERIDOO STAND**

- MATERIAL** Black powder coated aluminum
- FEATURES** Steady support for your didgeridoo  
Stable tripod base  
Soft padding  
Rubber yoke for added protection
- FINISH** Black

**11 CHIMES STAND**

- MATERIAL** Chrome plated steel
- FEATURES** Full angle and height adjustability  
Secure angle clamps  
Telescoping stem

**12 PROFESSIONAL DOUMBЕК/IBO STAND**

- MATERIAL** Chrome plated steel
- FEATURES** Foam padded ring  
Fully height and angle adjustable  
Double braced tripod legs
- INCLUDES** Hex key  
Memory lock

**13 PERCUSSION STAND**

- MATERIAL** Chrome plated steel
- FEATURES** Height adjustable  
Double braced tripod legs
- INCLUDES** Hex key  
Memory locks  
2 straight rods  
2 angled rods  
2 Z-shaped rods

# TABLES & CAJON RACK

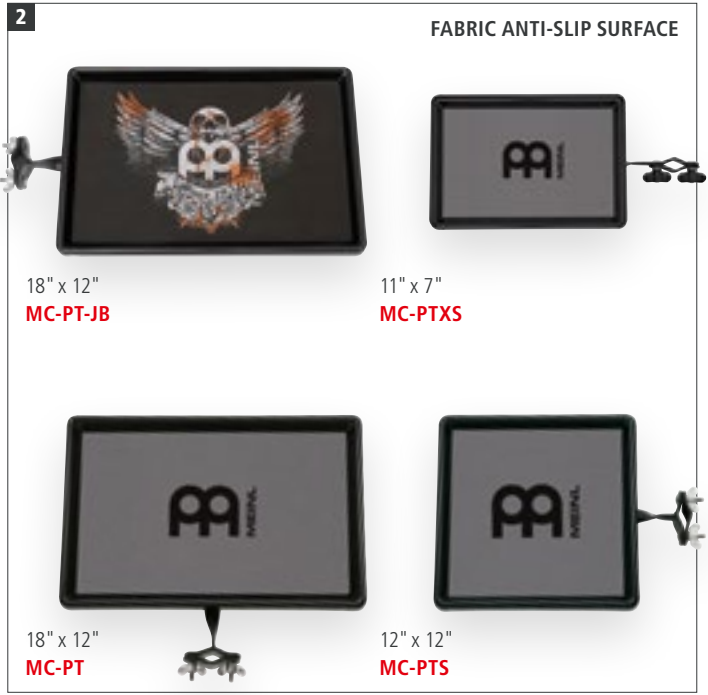

## 1 LAPTOP TABLE STAND

**SIZE** 20" x 12 1/2"  
**MATERIAL** Perforated metal plate  
**FEATURES** Holds laptops up to 17"  
Stoppers and hook and loop fastener to secure the laptop  
Holder for headphones  
Cord strain relief

## 2 PERCUSSION TABLES

**SIZES** **MC-PT:** 18" x 12"  
**MC-PT-JB:** 18" x 12"  
**MC-PTS:** 12" x 12"  
**MC-PTXS:** 11" x 7"  
**MATERIALS** **MC-PT, MC-PT-JB, MC-PTS:** Premium fiberglass  
**MC-PTXS:** Plastic  
**FEATURES** Fabric anti-slip surface; Adjustable angle; Strong mounting clamp  
**MC-PT-JB:** Jawbreaker motif

## 3 PERCUSSION WORKSTATION

**MATERIAL** Black powder coated steel  
**FEATURES** Fully height adjustable  
Angle adjustable top bar  
Heavy-duty construction  
Infinitely expandable  
Fabric anti-slip surfaces  
Colour doesn't interfere with stage lighting

**INCLUDES** 1 x Padded fiberglass percussion table, 22" x 24"  
2 x Padded fiberglass percussion tables, 18" x 12" (attachable)  
1 x Vertical bar, 30"  
2 x Vertical bars, 15" (attachable)  
4 x Straight rods with hook  
3 x Angled rods with hook  
1 x Z-shaped rod with hook

## 4 PERCUSSION TABLE STAND

**SIZE** 16" x 22"  
**MATERIALS** Table: Premium fiberglass  
Stand: Chrome plated steel  
**FEATURES** Fabric anti-slip surface  
Fully height adjustable  
Double braced tripod legs  
**INCLUDES** Hex key; Memory lock

## 5 ERGO TABLE

**SIZE** 20" x 34"  
**MATERIALS** Table: Premium fiberglass  
Stand: Chrome plated steel  
**FEATURES** Fabric anti-slip surface  
Padded edge  
Fully height adjustable  
Ergonomic shape for more efficiency  
Double braced tripod legs  
**INCLUDES** Hex key; Memory lock

**4** ALL MEINL TRIPOD STANDS ARE EQUIPPED WITH MEMORY AND QUICK LOCKS

16" x 22"  
**TMPTS**

MIN. 30"  
MAX. 46 3/4"

**5** ERGONOMIC SHAPE FOR MORE EFFICIENCY

20" x 34"  
**TMPETS**

MIN. 30"  
MAX. 46 3/4"

**6**

CLAMP WITH STRAIGHT ROD

CLAMP WITH Z-SHAPED ROD

10" x 16"  
PADDED TABLE

Black powder coated  
**TMCR**

**7**

**CR-CLAMP1**      **CR-CLAMP2**      **CR-CLAMP3**

**8**

**CR-BAR**      T-CONNECTOR FOR VARIABLE MOUNTING POSSIBILITIES

**9**

**MC-R1-H**    **MC-R2-H**    **MC-R3-H**

**6 CAJON RACK**  
**SIZE** 28 1/2" W x 46" H x 25 1/4" D  
**MATERIAL** Black powder coated aluminum  
**FEATURES** Perfect height for seated cajon players  
 Keep necessary percussion accessories close by  
 Mount tambourines and other small drums  
 Percussion table for shakers and other small instruments  
**INCLUDES** Padded table, 10" x 16"  
 Clamp with straight rod  
 Clamp with z-shaped rod

**7 CAJON RACK MOUNTING CLAMPS**  
**MATERIALS** Chrome plated steel  
 Black powder coated die cast steel  
**FEATURES** Clamp and rod for added accessories to the MEINL Cajon Rack  
 Rod fits any common tambourine, block or cowbell  
 Strong mounting clamp  
**INCLUDES** Mounting bracket  
 Z-shaped rod (CR-CLAMP1)  
 Straight rod (CR-CLAMP2)  
 L-shaped rod (CR-CLAMP3)

**8 BAR FOR CAJON RACK**  
**SIZE** 11" long  
**MATERIAL** Black powder coated aluminum  
**FEATURES** T-connector for variable mounting possibilities  
 Place anywhere on the MEINL Cajon Rack  
 Great for expanding your percussion assortment  
**INCLUDES** Mounting bracket

**9 RODS WITH HOOK**  
**SHAPES** **MC-R1-H:** Straight rod  
**MC-R2-H:** Angled rod  
**MC-R3-H:** Z-shaped rod  
**MATERIAL** Chrome plated steel  
**FEATURES** Knurled surface  
 Hook

# HARDWARE

**1** **HOLDS TAMBOURINES AND SHAKERS**



Mini Percussion Rack  
**MC-SHTA**

**2** **PADDED SURFACE**



Tambourine Holder  
**MC-TH**

**3**



Wood Block Holder  
**MWBH1**

**4**



Güiro Holder  
**MC-GU**

MIN. 2 1/2"  
MAX. 3 3/4"

**5** **FOR TURBO CABASA, MEDIUM**



Cabasa Holder  
**MC-CA**

**6** **ENABLES YOU TO PLAY THE IBO WITH BOTH HANDS ON A TABLE**



Ibo Holder  
**TMIH**

**7**



Drumstick Holders  
**MEINL MC-DSH**

Jawbreaker  
**MC-DSH-JB**

**8**



Shaker Holder  
**MC-SH**

MIN. 1"  
MAX. 6"

**9** **NEW**



Frame Drum Holder  
**MC-FDH**

**10**

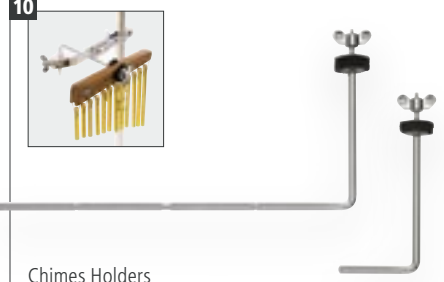

Chimes Holders  
**MC-CHL**

**MC-CH**

**11**



Triangle Holder  
**MC-TRI**

**12**



Triangle Clamp  
**CLAMP-TRI**

## 1 MINI PERCUSSION RACK

**MATERIALS** Black powder coated steel  
Foam rubber

**FEATURES** Holds tambourines and shakers; Clamps on any common mic or percussion stand; Perfect solution for keeping percussion pieces close by

**COLOUR** Black

## 2 TAMBOURINE HOLDER

**MATERIAL** Chrome plated steel

**FEATURES** Rubber pads; Padded surface

## 3 WOOD BLOCK HOLDER

**MATERIAL** Chrome plated steel

## 4 GÜIRO HOLDER

**MATERIAL** Chrome plated steel

**FEATURE** Rubber pads

## 5 CABASA HOLDER

**MATERIAL** Chrome plated steel

**FEATURES** Strong mounting clamp; Padded surface

## 6 IBO HOLDER

**MATERIAL** Black powder coated steel

**FEATURE** Foam padded base

**INCLUDES** Hex key

## 7 DRUMSTICK HOLDERS

**MATERIAL** Chrome plated steel  
Black textile pouch

**FEATURE** Strong mounting clamp

**FINISHES** **MC-DSH:** MEINL  
**MC-DSH-JB:** Jawbreaker motif

## 8 SHAKER HOLDER

**MATERIAL** Chrome plated steel

**FEATURES** Rubber pads; Length adjustable

## 9 FRAME DRUM HOLDER

**MATERIALS** Chrome plated steel  
Anodized aluminum

**FEATURE** Fully adjustable for any frame drum size

## 10 CHIMES HOLDERS

**SIZES** **MC-CH:** Regular  
**MC-CHL:** Large

**MATERIAL** Chrome plated steel

**FEATURES** Knurled surface; Foam washer

## 11 TRIANGLE HOLDER

**MATERIAL** Chrome plated steel

**FEATURES** Knurled surface; Nylon cord

## 12 TRIANGLE CLAMP

**MATERIAL** Chrome plated steel

**FEATURES** Holds any triangle in place; Easy mountable



**13**

Bass Drum Cowbell Holders  
**MC-STBD**      **MC-BD**

**14**

FITS ON ALL COMMON BASS DRUM PEDALS AND FIRMLY HOLDS COWBELLS, BLOCKS, OR TAMBOURINES

Pedal Mount  
**PM-1**

**15**

Pedal Mount for Cymbals  
**PM-2**

**16**

**NEW**

**MC-CY1**

**NEW**

**MC-CY2**

**MC-CY**

Cymbal Holder Attachments

**17**

Cymbal Stackers  
**MC-CYS**      **MC-CYS8**      **MC-CYS8-S**

**18**

Cymbal Attachment  
**MCA**

**19**

X-Hat Auxiliary HiHat Arm  
**MXH**

**13 BASS DRUM COWBELL HOLDERS**

**MATERIALS** **MC-BD:** Chrome plated steel  
**MC-STBD:** Black powder coated steel

**FEATURES** Rubber pads  
**MC-BD:** Fully adjustable

**INCLUDES** **MC-BD:** L-shaped rod

**14 PEDAL MOUNT**

**MATERIAL** Black powder coated steel

**FEATURES** Height adjustable legs; Metal spikes

**INCLUDES** 2 differently sized L-rods

**15 PEDAL MOUNT FOR CYMBALS**

**MATERIAL** Black powder coated steel

**FEATURES** For foot activated cymbal crashes; Fits any common bass drum pedal; Holds cymbals ranging from 16" to 22"

**INCLUDES** Cymbal arm

**16 CYMBAL HOLDER ATTACHMENTS**

**MATERIAL** Chrome plated steel

**FEATURES** Knurled surface; Felt washers; For splashes or small crashes; Easy placement on a drumkit, cajon set or percussion rig

**MC-CY:** Z-shaped 3/8" rod  
**MC-CY1:** S-shaped 3/8" rod  
**MC-CY2:** Z-shaped 3/8" rod with extra-long knurled end

**17 CYMBAL STACKERS**

**SIZES** **MC-CYS:** Ø 6 mm, long  
**MC-CYS8:** Ø 8 mm, long  
**MC-CYS8-S:** Ø 8 mm, short

**MATERIAL** Chrome plated steel

**FEATURE** Felt washers

**18 CYMBAL ATTACHMENT**

**MATERIAL** Chrome plated steel

**FEATURES** Multi-clamp; Cymbal boom arm

**19 X-HAT AUXILIARY HIHAT ARM**

**MATERIAL** Chrome plated steel

**FEATURES** Easy to attach and position at any height or angle; Finely adjust the degree of tension on the cymbals

# HARDWARE

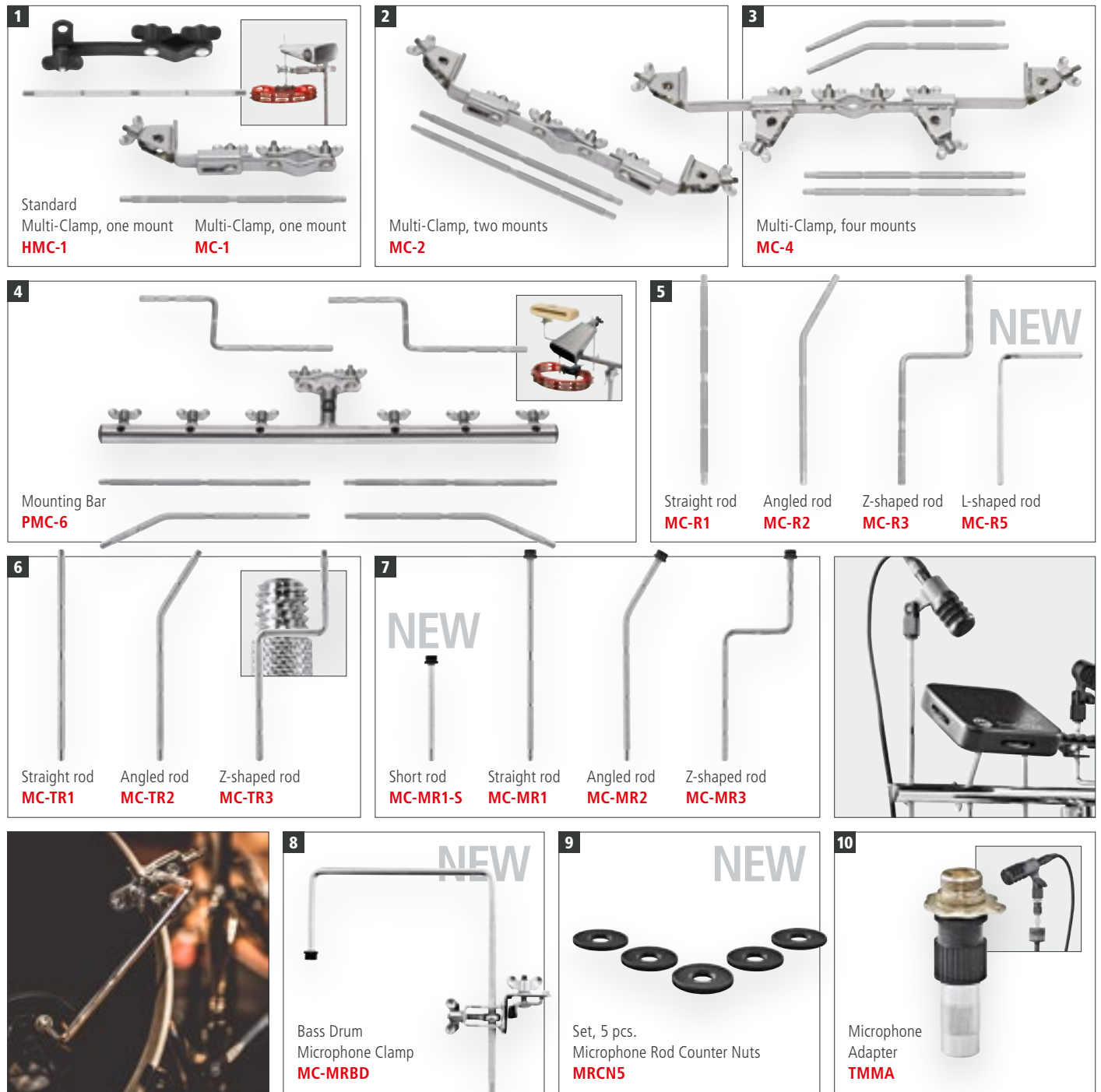

## 1 MULTI-CLAMPS, ONE MOUNT

**MATERIALS** **HMC-1:** Black powder coated steel  
**MC-1:** Chrome plated steel  
**FEATURES** Strong mounting clamp  
**MC-1:** Length adjustable  
**INCLUDES** Straight rod

## 2 MULTI-CLAMP, TWO MOUNTS

**MATERIAL** Chrome plated steel  
**FEATURES** Length adjustable; Strong mounting clamp  
**INCLUDES** 2 straight rods

## 3 MULTI-CLAMP, FOUR MOUNTS

**MATERIAL** Chrome plated steel  
**FEATURES** Length adjustable; Strong mounting clamp  
**INCLUDES** 2 straight and 2 angled rods

## 4 MOUNTING BAR

**MATERIAL** Chrome plated steel  
**INCLUDES** 2 straight, 2 angled and 2 z-shaped rods

## 5 RODS

**MATERIAL** Chrome plated steel  
**FEATURES** Knurled surface; Available as a straight, angled, z-shaped, or l-shaped rod

## 6 THREADED PERCUSSION RODS

**MATERIAL** Chrome plated steel  
**FEATURES** Threaded tip to mount any standard 3/8" threaded percussion instrument; Available as a straight, angled, or z-shaped rod; Expand your sound options

## 7 RODS WITH THREADED MICROPHONE CONNECTOR

**MATERIAL** Chrome plated steel  
**FEATURES** 3/8" diameter rod with threaded end; Designed to attach microphones; Use with the MEINL Rim Clamp; Available as a short, straight, angled, or z-shaped rod

**MC-MR1-S:** Perfect for micing toms, snares or congas

**INCLUDES** Microphone screw adapter

## 8 BASS DRUM MICROPHONE CLAMP

**MATERIAL** Chrome plated steel  
**FEATURES** U-shape 3/8" diameter rod with threaded end to attach a microphone; Standard bass drum hoop clamp; Easily adjust the distance between your mic and kick drum; Eliminates the need for an additional microphone stand

## 9 MICROPHONE ROD COUNTER NUTS

**MATERIAL** Black powder coated steel  
**FEATURES** Set of 5 counter nuts; Securely lock your microphone attachments; Use with MEINL Microphone rods with threaded connection (sold separately)

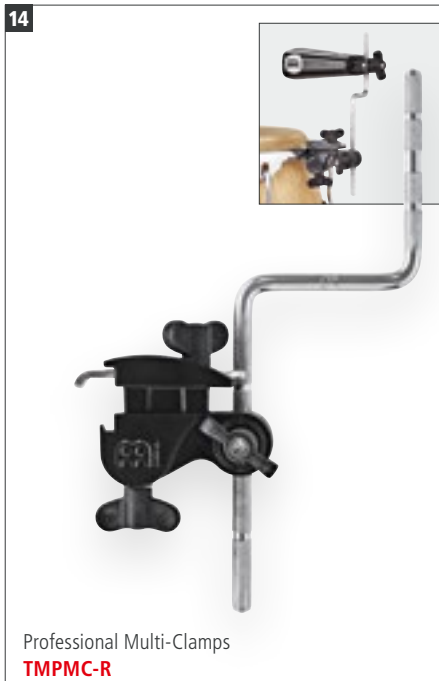
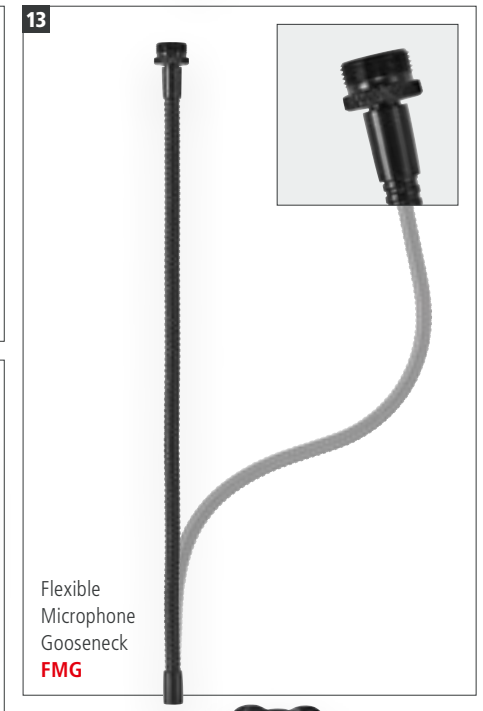

**10 MICROPHONE ADAPTER**

**MATERIAL** Chrome plated steel  
**FEATURES** Turns your cymbal stand into a microphone stand; 8 mm threaded attachment  
**INCLUDES** 5/8" male to 3/8" mic screw adapter

**11 RIM CLAMPS**

**MATERIALS** Black powder coated steel  
**RIMCLAMP:** Chrome plated steel (L-shaped rod)  
**RIMCLAMP-M:** Metal (Gooseneck)  
**FEATURES** Fully height and angle adjustable; Fits to any common drum rim  
**RIMCLAMP, RIMCLAMP-2:** Holds percussion accessories right where you need them; Great for percussion rigs, drum kit setups, and marching drums; Also works with most small cymbal attachment arms

**INCLUDES**

**RIMCLAMP-M:** Get perfect mic placement in tight spaces; Works with all 3/8" or 5/8" mic clips (Mic clip not included)  
**RIMCLAMP:** L-shaped rod  
**RIMCLAMP-M:** Flexible Microphone Gooseneck

**12 CLAMP**

**MATERIAL** Chrome plated steel  
**FEATURE** Compact and solid design

**13 FLEXIBLE MICROPHONE GOOSENECK**

**SIZE** 32.5 cm / 12.8"  
**MATERIAL** Metal  
**FEATURES** Optimal microphone placement; No additional stand required; Fits in the MEINL Rim Clamp; 3/8" and 5/8" threads

**14 PROFESSIONAL MULTI-CLAMPS**

**MATERIALS** Black powder coated die cast steel  
**TMPMC-G:** Metal (Gooseneck)  
**TMPMC-R:** Chrome plated steel (Z-shaped rod)  
**FEATURES** 360-degree adjustable 3/8" rod eye bolt mount  
**TMPMC:** Strong clamp secures to any drum set or percussion rim; Fine tune the placement of your percussion gear  
**TMPMC-G:** Removable flexible microphone gooseneck; Strong clamp secures to any drum set or percussion rim; Get optimal placement of your microphone  
**TMPMC-R:** Removable Z-shaped 3/8" rod to mount percussion instruments; Strong clamp secures to any drum set or percussion rim; Get optimal placement of your gear

# BAGS



## BAGS

**MATERIALS** Heavy-duty nylon  
(unless noted otherwise)

### 1 CAJON GIG BAG

**MEASURES** 20 1/2" W x 12" H x 12" D

**FEATURES** Carrying grip

### 2 PROFESSIONAL CAJON BAGS

**MEASURES** **MCJB, MCJB-CG:**

20 1/2" W x 12" H x 12" D

**MCJB-L:** 23 1/2" W x 17" H x 15" D

**MATERIAL** **MCJB-CG:** Ripstop Fabric

**FEATURES** Padded shoulder strap; External pocket;  
Carrying grip

**MCJB-L:** Fits bigger sized cajons

**FINISH** **MCJB-CG:** Carbon Grey

### 3 DELUXE CAJON BAG

**MEASURES** 20 1/2" W x 12" H x 12" D

**FEATURES** Synthetic fur; Padded shoulder strap;  
External pocket; Carrying grip

### 4 DELUXE BASS PEDAL CAJON BAG

**MEASURES** 21 1/2" W x 17" H x 14 1/2" D

**FEATURES** Synthetic fur; Padded shoulder strap;  
External pocket; Carrying grip

### 5 PROTECTION COVER FOR HEADLINER® CAJONS

**FEATURE** Fits all HCAJ1 models

### 6 CAJON BACKPACK

**MEASURES** 13 1/2" W x 19 3/4" H x 14" D

**FEATURES** Backpack; Carrying grip

### 7 CAJON BACKPACK PRO

**MEASURES** 12" W x 20 1/2" H x 12" D

**MATERIAL** Ripstop Fabric

**FEATURES** Padded backpack shoulder straps;  
External pocket; Carrying grip

**FINISH**

Carbon Grey

### 8 JAM CAJON GIG BAG

**MEASURES** 12" W x 16" H x 12" D

**FEATURES** Fits all Jam Cajon models;  
Strong carrying grip; Two-way zipper

### 9 PROFESSIONAL SLAPTOP CAJON BAG

**MEASURES** 23" W x 15" H x 13" D

**FEATURES** Padded shoulder strap; External pocket;  
Carrying grip

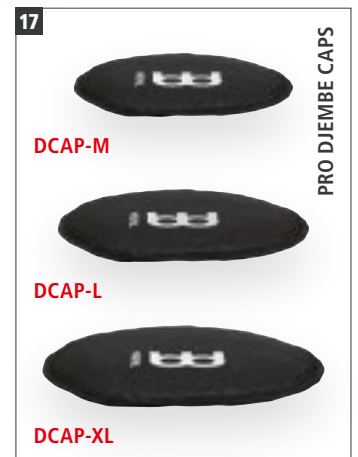

**10 PROFESSIONAL HYBRID SLAPTOP CAJON BAG**  
**MEASURES** 17 1/2" W x 13" H x 8" D  
**FEATURES** Padded shoulder strap; Carrying grip

**11 TRAVEL CAJON GIG BAG**  
**SIZE** 12"  
**FEATURES** Double-slide zipper; Carrying grip

**12 PROFESSIONAL CAJON PEDAL BAG**  
**MEASURES** 21" W x 12" H x 15" D  
**FEATURES** Padded shoulder strap; External pocket; Carrying grip; Padded dividers

**13 DELUXE DJEMBE BAGS**  
**SIZES** **M:** Medium (up to 12")  
**L:** Large (up to 13 1/2")  
**FEATURES** Synthetic fur; External pocket; Padded backpack straps; Carrying grip

**14 STANDARD DJEMBE BAGS**  
**SIZES** **MSTDJB10:** Medium (10")  
**MSTDJB12:** Large (12")  
**FEATURES** External pocket; Shoulder strap; Carrying grip

**15 PROFESSIONAL DJEMBE BAGS**  
**SIZES** **S:** Small (up to 10")  
**M:** Medium (up to 12")  
**L:** Large (up to 13 1/2")  
**FEATURES** External pocket; Carrying grip  
**MDJB-M, MDJB-L:** Padded backpack straps

**16 DJEMBE GIG BAG**  
**FEATURES** Carrying grip; Shoulder strap; Outer pocket

**17 PROFESSIONAL DJEMBE CAPS**  
**SIZES** **M:** 10"; **L:** 12"; **XL:** 13"

**18 CONGA GIG BAG**  
**FEATURES** Carrying grip; Shoulder strap; Outer pocket

**19 PROFESSIONAL CONGA BAGS**  
**SIZES** **MCOB-11:** 11"  
**MCOB-1134:** 11 3/4"  
**MCOB-1212:** 12 1/2"  
**FEATURES** Additional upright zipper; External pocket; Padded backpack straps; Carrying grip

**20 PROFESSIONAL PANDEIRO BAGS**  
**SIZES** **MPAB-10:** 10"; **MPAB-12:** 12"  
**FEATURES** Double-slide zipper; Shoulder strap; External pocket  
**MPAB-12:** Also fits for our 10" Tambourines

**21 TAMBOURINE GIG BAG**  
**SIZE** 10"  
**FEATURES** Sturdy zipper; Carrying grip

# BAGS



## BAGS

**MATERIALS** Heavy-duty nylon  
(unless noted otherwise)

### 1 BONGO GIG BAG

**SIZE** Bongos up to 7 1/2" Macho & 8 1/2" Hembra  
**FEATURE** Carrying grip

### 2 PROFESSIONAL BONGO BAG

**FEATURES** Additional room for accessories; Padded shoulder strap; Carrying grip; Padded separator

### 3 PROFESSIONAL TIMBALES BAG

**SIZE** 14" & 15"  
**FEATURES** External pocket for stand and cowbell; Padded shoulder strap; Carrying grip; Padded separator

### 4 PROFESSIONAL SURDO BAGS

**SIZES** **MSUB-16:** 16" x 20"  
**MSUB-18:** 18" x 22"  
**MSUB-20:** 20" x 24"  
**MSUB-22:** 22" x 24"

**FEATURES** Double-slide zipper; Padded backpack straps; Carrying grip; External pocket

### 5 PROFESSIONAL TIMBA BAGS

**SIZES** **MTIMB-1428:** 14" x 28"  
**MTIMB-1435:** 14" x 35"

**FEATURES** Double-slide zipper; Padded backpack straps; Carrying grip; External pocket

### 6 PROFESSIONAL TANTAM BAG

**SIZE** 14" x 28"  
**FEATURES** Double-slide zipper; Padded backpack straps; Carrying grip; External pocket

### 7 PROFESSIONAL REBOLO BAG

**SIZE** 12" x 18"  
**FEATURES** Double-slide zipper; Padded shoulder strap; Carrying grip; External pocket

### 8 PROFESSIONAL REPINIQUE BAGS

**SIZES** **MREB-10:** 10" x 10"  
**MREB-12:** 12" x 12"  
**FEATURES** Double-slide zipper; Shoulder strap; Carrying grip; External pocket

### 9 PROFESSIONAL TAMBORIM BAG

**SIZE** 6"  
**FEATURES** Double-slide zipper; Shoulder strap; External pocket



**MQW-6**      **MQW-7**      **MQW-10**

PRO CUIXA BAGS



**MCA-12**      **MCA-12T**      **MCA-14**

PRO CAIXA BAGS



**MCHB**

PRO CHIMES BAG



**MFDB-14**      **MFDB-16**      **MFDB-18**      **MFDB-20**      **MFDB-22**

PRO FRAME DRUM BAGS



**MFDB-12BE**      **MFDB-14BE**      **MFDB-14IBO**      **MFDB-18BO**      **MFDB-22-D**

PRO DEEP SHELL FRAME DRUM BAGS



**MFDB-7KA**

PRO KANJIRA BAG

### 10 PROFESSIONAL CUIXA BAGS

- SIZES**      **MQW-6:** 6"  
**MQW-7:** 8"  
**MQW-10:** 10"
- FEATURES**      Padded shoulder strap; Carrying grip;  
 External pocket

### 11 PROFESSIONAL CAIXA BAGS

- SIZES**      **MCA-12:** 12" x 4 1/2"  
**MCA-12T:** 12" x 6"  
**MCA-14:** 14" x 4"
- FEATURES**      Double-slide zipper; Shoulder strap;  
 Extra pocket for spare heads;  
 Carrying grip; External pocket

### 12 PROFESSIONAL CHIMES BAG

- FEATURES**      Stores up to 2 chimes; Carrying grip;  
 Inner hook and loop fastener straps;  
 2 internal pockets

### 13 PROFESSIONAL FRAME DRUM BAGS

- SIZES**      **MFDB-14:** 14", 2 1/2" deep  
**MFDB-16:** 16", 2 1/2" deep  
**MFDB-18:** 18", 2 1/2" deep  
**MFDB-20:** 20", 2 1/2" deep  
**MFDB-22:** 22", 2 1/2" deep
- FEATURES**      Double-slide zipper; Shoulder strap;  
 Carrying grip

### 14 PROFESSIONAL DEEP SHELL FRAME DRUM BAGS

- SIZES**      **MFDB-12BE:** 12" x 4"  
**MFDB-14BE:** 14" x 4"  
**MFDB-14IBO:** 14" x 6"  
**MFDB-18BO:** 18" x 4"  
**MFDB-22-D:** 22" x 4"
- FEATURES**      Double-slide zipper; Shoulder strap;  
 Carrying grip

### 15 PROFESSIONAL KANJIRA BAG

- SIZE**      8 1/2" x 2 1/2"
- FEATURES**      Double-slide zipper; Shoulder strap;  
 External pocket

# BAGS



## BAGS

**MATERIALS** Heavy-duty nylon  
(unless noted otherwise)

### 1 STANDARD DARBUKA BAG

**SIZE** Medium  
**FEATURES** Carrying grip; Shoulder strap; Outer pocket

### 2 PROFESSIONAL DARBUKA BAG

**FEATURES** Double-slide zipper; Additional upright zipper; Padded shoulder strap; Carrying grip; External pocket

### 3 PROFESSIONAL IBO BAGS

**SIZES** **S:** Small (9 3/4" W x 13 1/3" H x 9 3/4" D)  
**M:** Medium (11" W x 14 1/2" H x 11" D)  
**L:** Large (11 3/4" W x 15" H x 11 3/4" D)  
**FEATURES** Padded shoulder strap; Carrying grip; External pocket

### 4 STANDARD DOUMBЕК BAG

**SIZE** Medium  
**FEATURES** Carrying grip; Shoulder strap; Outer pocket

### 5 PROFESSIONAL DOUMBЕК BAGS

**SIZES** **MDOB:** Medium  
**MDOB-L:** Large  
**FEATURES** Double-slide zipper; Additional upright zipper; Padded shoulder strap; Carrying grip; External pocket

### 6 STRAIGHT DIDGERIDOO BAG

**SIZE** 53"  
**FEATURES** Padded shoulder strap; External pocket

### 7 PRO DIDGERIDOO BAG

**SIZE** 58"  
**FEATURES** Padded shoulder strap; External pocket

### 8 PERCUSSION BACKPACK

**MATERIAL** Ripstop Fabric  
**FEATURES** Travel backpack for small percussion instruments; Numerous pockets on the inside and outside; Padded backpack shoulder straps; Carrying grip  
**FINISH** Carbon Grey

### 9 HAND PERCUSSION BAGS

**SIZES** **M:** Medium  
**L:** Large  
**FEATURES** Great for cowbells, blocks or small hand percussion; Drawstring top; Durable nylon prevents scuffs and scratches; No hassle storage or travel

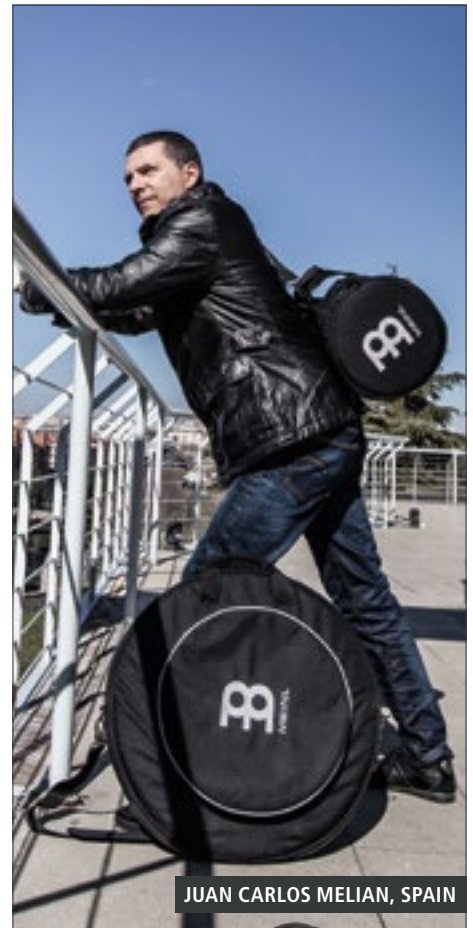

**10 CYMBAL GIG BAG**

SIZE 22"  
 FEATURES Shoulder strap; Carrying grip

**11 PROFESSIONAL CYMBAL BAG**

SIZE 22"  
 FEATURES Padded dividers; Padded shoulder strap

**12 PROFESSIONAL CYMBAL BACKPACK**

SIZE 22"  
 FEATURES External hihat / splash compartment; Glow-in-the-dark MEINL logo; Two backpack straps on the backside

**13 RIPSTOP CYMBAL BACKPACK**

SIZE 22"  
 MATERIAL Ripstop Fabric  
 FEATURES Constructed of durable, lightweight ripstop material; 15" external hihat pocket; Accessories pocket on back side; Three thick cymbal dividers sewn into bag; Equipped with both heavy-duty backpack shoulder straps

**14 COMPACT STICK BAG**

FEATURE Carrying grip

**15 PROFESSIONAL STICK BAGS**

FEATURES External pockets; Shoulder straps; Extension straps

COLOURS **MSB-1:** Black  
**MSB-1-C1:** Original Camouflage  
**MSB-2:** The Horns

**16 DELUXE STICK BAG**

MATERIAL Padded synthetic leather  
 FEATURES External pockets; Shoulder straps; Elastic cord attachments



# MEIN VIVA RHYTHM



Sometimes a Drum Circle is a big party, sometimes it's more like a ceremony, and other times it's orientated to a specific goal or message. The Drum Circle is a very adaptable technology to meet a broad spectrum of social purpose. For many people it is an initiation into a new level of self and group awareness. It definitely gets us moving!

No matter who we are, the call of the drum has the potential to elevate our human experience and people's lives become better because of that. Facilitating Rhythm Circles is an honor, a privilege, and also a responsibility. It is a fascinating and rewarding commitment.

**Rhythm is a way of Life.** [Bill Saragosa]

Djembes	02
Congas	04
Bass Drums	06
Stack Drum Sets	08
Timbas	08
Cajons	09
Hand Percussion	10
Bags	11

# DJEMBES

1

## BOOM SERIES

CUTTING SOUNDS WITH SHARP ATTACK



14" x 26 1/4"  
VR-SDJ14-SH

12" x 23"  
VR-SDJ12-SH

10" x 19 1/2"  
VR-SDJ10-SH

9" x 16 1/2"  
VR-SDJ9-SH

8" x 16 1/4"  
VR-SDJ8-SH

2



THE POP OFF DJEMBE HEADS MAY BE ALSO PLAYED BY THEMSELVES AS A SMALL HAND DRUM

Set  
VR-SDJSET-SH

## SOFT SOUND SERIES

SOFTER SOUNDS WITH GREAT LOW END TONES



14" x 26 1/4"  
VR-SDJ14-NH

12" x 23"  
VR-SDJ12-NH

10" x 19 1/2"  
VR-SDJ10-NH

9" x 16 1/2"  
VR-SDJ9-NH

8" x 16 1/4"  
VR-SDJ8-NH



STACKABLE FOR EASY STORAGE AND TRANSPORTATION

Set  
VR-SDJSET-NH

### 1 COMMUNITY DJEMBES

**SIZES**  
**VR-SDJ8**  
 8" head diameter, 16 1/4" height  
**VR-SDJ9**  
 9" head diameter, 16 1/2" height  
**VR-SDJ10**  
 10" head diameter, 19 1/2" height  
**VR-SDJ12**  
 12" head diameter, 23" height  
**VR-SDJ14**  
 14" head diameter, 26 1/4" height

**MATERIALS**  
 Synthetic shell  
**SH:** Synthetic head  
**NH:** Napa head

**FEATURES**  
 Synthetic shell is perfect for outdoor playing  
 Non-slip rubber bottom  
 Great for any skill level or style  
**SH:** Pre-tuned synthetic head for cutting sounds with sharp attack  
**NH:** Pre-tuned Napa head creates softer, warmer sound

### 2 3-IN-1 DJEMBES

**SIZES**  
 8" head diameter, 16 1/4" height  
 10" head diameter, 19 1/2" height  
 12" head diameter, 23" height

**MATERIALS**  
 Synthetic shell  
**SH:** Synthetic head  
**NH:** Napa head

**FEATURES**  
 Synthetic shell is perfect for outdoor playing  
 Non-slip rubber bottom  
 Great for any skill level or style  
 Stackable for easy storage and transportation  
**SH:** Pre-tuned synthetic head for cutting sounds with sharp attack  
**NH:** Pre-tuned Napa head creates softer, warmer sound

**3**

**BOOM SERIES**  
CUTTING SOUNDS WITH SHARP ATTACK

**CAN BE TAKEN OFF THE DRUM INSTANTLY WITHOUT ANY TUNING**



14" x 26 1/4" **VR-SDJPO14-SH**    12" x 23" **VR-SDJPO12-SH**    10" x 19 1/2" **VR-SDJPO10-SH**    9" x 16 1/2" **VR-SDJPO9-SH**    8" x 16 1/4" **VR-SDJPO8-SH**

**SOFT SOUND SERIES**  
SOFTER SOUNDS WITH GREAT LOW END TONES



14" x 26 1/4" **VR-SDJPO14-NH**    12" x 23" **VR-SDJPO12-NH**    10" x 19 1/2" **VR-SDJPO10-NH**    9" x 16 1/2" **VR-SDJPO9-NH**    8" x 16 1/4" **VR-SDJPO8-NH**

**4**

14" **VR-POH14-SH**  
12" **VR-POH12-SH**  
10" **VR-POH10-SH**  
9" **VR-POH9-SH**  
8" **VR-POH8-SH**



14" **VR-POH14-NH**  
12" **VR-POH12-NH**  
10" **VR-POH10-NH**  
9" **VR-POH9-NH**  
8" **VR-POH8-NH**



**MAY BE PLAYED BY THEMSELVES AS A SMALL HAND DRUM**

**DJEMBES**

**3 POP OFF DJEMBES**

- SIZES**
- VR-SDJPO8**  
8" head diameter, 16 1/4" height
  - VR-SDJPO9**  
9" head diameter, 16 1/2" height
  - VR-SDJPO10**  
10" head diameter, 19 1/2" height
  - VR-SDJPO12**  
12" head diameter, 23" height
  - VR-SDJPO14**  
14" head diameter, 26 1/4" height

- MATERIALS**
- Synthetic shell
  - SH:** Synthetic head
  - NH:** Napa head

- FEATURES**
- Synthetic shell is perfect for outdoor playing
  - Non-slip rubber bottom
  - Great for any skill level or style
  - SH:** Removable, pre-tuned synthetic head for cutting sounds with sharp attack
  - NH:** Removable, pre-tuned Napa head creates softer, warmer sound

**4 POP OFF HEADS**

- SIZES**
- VR-POH8:** 8" head diameter
  - VR-POH9:** 9" head diameter
  - VR-POH10:** 10" head diameter
  - VR-POH12:** 12" head diameter
  - VR-POH14:** 14" head diameter

- MATERIALS**
- SH:** Synthetic head
  - NH:** Napa head
- FEATURES**
- Available as Napa style (soft sound) or standard synthetic (sharp sounds)
  - Instantly take on or off your MEINL VivaRhythm® Pop Off Djembe
  - May be played by themselves as a small hand drum
  - Nylon-loop for easy removal
  - Pre-tuned

# CONGAS

1

## BOOM SERIES

CUTTING SOUNDS WITH SHARP ATTACK



STACKABLE FOR EASY STORAGE AND TRANSPORTATION



11 1/2" x 24 1/2"  
VR-C115-SH

9 1/2" x 23"  
VR-C95-SH

8" x 21"  
VR-C8-SH

Set  
VR-CSET-SH

## SOFT SOUND SERIES

SOFTER SOUNDS WITH GREAT LOW END TONES



SETS INCLUDE THREE WOODEN BEATERS



11 1/2" x 24 1/2"  
VR-C115-NH

9 1/2" x 23"  
VR-C95-NH

8" x 21"  
VR-C8-NH

Set  
VR-CSET-NH

### 1 COMMUNITY CONGAS

**SIZES**  
**VR-C8**  
 8" head diameter, 21" height  
**VR-C95**  
 9 1/2" head diameter, 23" height  
**VR-C115**  
 11 1/2" head diameter, 24 1/2" height  
**VR-CSET**  
 8" x 21"; 9 1/2" x 23"; 11 1/2" x 24 1/2"

**MATERIALS**  
 Synthetic shell  
**SH:** Synthetic head  
**NH:** Napa head

**FEATURES**  
 Synthetic shell is perfect for outdoor playing  
 Non-slip rubber bottom  
 Great for any skill level or style  
 Stackable for easy storage and transportation  
**SH:** Pre-tuned synthetic head for cutting sounds with sharp attack  
**NH:** Pre-tuned Napa head creates softer, warmer sound

**INCLUDES**  
**VR-CSET:** Three wooden beaters



2

**CAN BE TAKEN OFF THE DRUM INSTANTLY WITHOUT ANY TUNING**

**BOOM SERIES**  
CUTTING SOUNDS WITH SHARP ATTACK



11 1/2" x 24 1/2"  
**VR-CP0115-SH**

9 1/2" x 23"  
**VR-CP095-SH**

8" x 21"  
**VR-CP08-SH**

Set  
**VR-CPOSET-SH**

3



11 1/2"  
**VR-POH115-SH**



9 1/2"  
**VR-POH95-SH**



8"  
**VR-POH8-SH**

**STACKABLE FOR EASY STORAGE AND TRANSPORTATION**

**SOFT SOUND SERIES**  
SOFTER SOUNDS WITH GREAT LOW END TONES

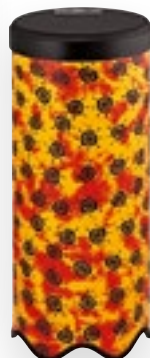

11 1/2" x 24 1/2"  
**VR-CP0115-NH**

9 1/2" x 23"  
**VR-CP095-NH**

8" x 21"  
**VR-CP08-NH**

Set  
**VR-CPOSET-NH**



11 1/2"  
**VR-POH115-NH**



9 1/2"  
**VR-POH95-NH**



8"  
**VR-POH8-NH**

**MAY BE PLAYED BY THEMSELVES AS A SMALL HAND DRUM**

CONGAS

**2 POP OFF CONGAS**

**SIZES**  
**VR-CP08**  
8" head diameter, 21" height  
**VR-CP095**  
9 1/2" head diameter, 23" height  
**VR-CP0115**  
11 1/2" head diameter, 24 1/2" height  
**VR-CPOSET**  
8" x 21"; 9 1/2" x 23"; 11 1/2" x 24 1/2"  
**MATERIALS**  
Synthetic shell  
**SH:** Synthetic head  
**NH:** Napa head

**FEATURES**  
Synthetic shell is perfect for outdoor playing  
Non-slip rubber bottom  
Great for any skill level or style  
Stackable for easy storage and transportation  
**SH:** Removable, pre-tuned synthetic head for cutting sounds with sharp attack  
**NH:** Removable, pre-tuned Napa head creates softer, warmer sound  
**INCLUDES**  
**VR-CPOSET:** Three wooden beaters

**3 POP OFF HEADS**

**SIZES**  
**VR-POH8:** 8" head diameter  
**VR-POH95:** 9 1/2" head diameter  
**VR-POH115:** 11 1/2" head diameter  
**MATERIALS**  
**SH:** Synthetic head  
**NH:** Napa head  
**FEATURES**  
Available as Napa style (soft sound) or standard synthetic (sharp sounds)  
Instantly take on or off your MEINL VivaRhythm® Pop Off Conga  
May be played by themselves as a small hand drum  
Nylon-loop for easy removal  
Pre-tuned

# BASS DRUMS

1

## BOOM SERIES

CUTTING SOUNDS WITH SHARP ATTACK



STACKABLE FOR EASY STORAGE AND TRANSPORTATION



14" x 23 1/2"  
VR-BD14-SH

12" x 19 1/2"  
VR-BD12-SH

10" x 18"  
VR-BD10-SH

Set  
VR-BDSET-SH

## SOFT SOUND SERIES

SOFTER SOUNDS WITH GREAT LOW END TONES



SETS INCLUDE THREE WOODEN BEATERS



14" x 23 1/2"  
VR-BD14-NH

12" x 19 1/2"  
VR-BD12-NH

10" x 18"  
VR-BD10-NH

Set  
VR-BDSET-NH

### 1 COMMUNITY BASS DRUMS

- SIZES**
- VR-BD10  
10" head diameter, 18" height
  - VR-BD12  
12" head diameter, 19 1/2" height
  - VR-BD14  
14" head diameter, 23 1/2" height
  - VR-BDSET  
10" x 18"; 12" x 19 1/2"; 14" x 23 1/2"

- MATERIALS**
- Synthetic shell
  - SH: Synthetic head
  - NH: Napa head

- FEATURES**
- Synthetic shell is perfect for outdoor playing
  - Non-slip rubber bottom
  - Great for any skill level or style
  - Lower tones with great resonance
  - Reverse Dot below the head for deeper sounds
  - Stackable for easy storage and transportation
  - SH: Pre-tuned synthetic head for cutting sounds with sharp attack
  - NH: Pre-tuned Napa head creates softer, warmer sound
- INCLUDES**
- VR-BDSET: Three wooden beaters

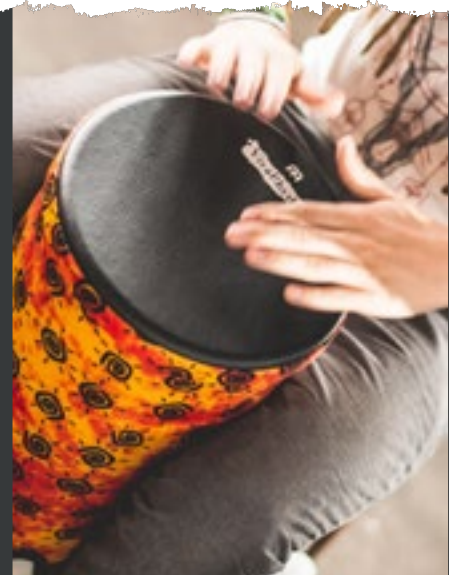



**2**

**CAN BE TAKEN OFF THE DRUM INSTANTLY WITHOUT ANY TUNING**

**BOOM SERIES**  
CUTTING SOUNDS WITH SHARP ATTACK



14" x 23 1/2"  
**VR-BDPO14-SH**

12" x 19 1/2"  
**VR-BDPO12-SH**

10" x 18"  
**VR-BDPO10-SH**

Set  
**VR-BDPOSET-SH**

**3**

14"  
**VR-POHBD14-SH**

12"  
**VR-POHBD12-SH**

10"  
**VR-POHBD10-SH**

**REVERSE-DOT FOR DEEPER SOUNDS**



**STACKABLE FOR EASY STORAGE AND TRANSPORTATION**

**SOFT SOUND SERIES**  
SOFTER SOUNDS WITH GREAT LOW END TONES



14" x 23 1/2"  
**VR-BDPO14-NH**

12" x 19 1/2"  
**VR-BDPO12-NH**

10" x 18"  
**VR-BDPO10-NH**

Set  
**VR-BDPOSET-NH**

14"  
**VR-POHBD14-NH**

12"  
**VR-POHBD12-NH**

10"  
**VR-POHBD10-NH**

**BASS DRUMS**

**2 POP OFF BASS DRUMS**

**SIZES** **VR-BDPO10**  
10" head diameter, 18" height  
**VR-BDPO12**  
12" head diameter, 19 1/2" height  
**VR-BDPO14**  
14" head diameter, 23 1/2" height  
**VR-BDPOSET**  
10" x 18"; 12" x 19 1/2"; 14" x 23 1/2"

**MATERIALS** Synthetic shell  
**SH:** Synthetic head  
**NH:** Napa head

**FEATURES** Synthetic shell is perfect for outdoor playing  
Non-slip rubber bottom  
Great for any skill level or style  
Lower tones with great resonance  
Reverse Dot below the head for deeper sounds  
Stackable for easy storage and transportation  
**SH:** Removable, pre-tuned synthetic head for cutting sounds with sharp attack  
**NH:** Removable, pre-tuned Napa head creates softer, warmer sound

**INCLUDES** **VR-BDPOSET:** Three wooden beaters

**3 POP OFF BASS DRUM HEADS**

**SIZES** **VR-POHBD10:** 10" head diameter  
**VR-POHBD12:** 12" head diameter  
**VR-POHBD14:** 14" head diameter

**MATERIALS** **SH:** Synthetic head  
**NH:** Napa head

**FEATURES** Available as Napa style (soft sound) or standard synthetic (sharp sounds)  
Instantly take on or off your MEINL VivaRhythm® Pop Off Bass Drum  
Reverse Dot below the head for deeper sounds  
May be played by themselves as a small hand drum  
Nylon-loop for easy removal  
Pre-tuned

# STACK DRUM SETS & TIMBAS

1

STACKABLE FOR EASY STORAGE AND TRANSPORTATION



BOOM SERIES  
CUTTING SOUNDS WITH SHARP ATTACK



Set  
VR-SDSET-SH

2

BASED ON THE SOUNDS OF TRADITIONAL SAMBA MUSIC



12" x 28"  
VR-T12-SH

CAN BE TAKEN OFF THE DRUM INSTANTLY WITHOUT ANY TUNING



SOFT SOUND SERIES  
SOFTER SOUNDS WITH GREAT LOW END TONES



Set  
VR-SDSET-NH



12" x 28"  
VR-T12-NH

## 1 STACK DRUM SETS

- SIZES** 9 1/2" head diameter, 17 1/4" height  
12" head diameter, 24" height
- MATERIALS** Synthetic shell  
**SH:** Synthetic head  
**NH:** Napa head
- FEATURES** Synthetic shell is perfect for outdoor playing  
Stackable for easy storage and transportation  
Non-slip rubber bottom  
Great for any skill level or style  
**SH:** Pre-tuned synthetic head for cutting sounds with sharp attack  
**NH:** Pre-tuned Napa head creates softer, warmer sound

## 2 TIMBAS

- SIZE** 12" head diameter, 28" height
- MATERIALS** Fiberglass shell  
**SH:** Synthetic head  
**NH:** Napa head
- FEATURES** Fiberglass shell is perfect for outdoor playing  
Based on the sounds of traditional Samba music  
Non-slip rubber bottom  
Great for any skill level or style  
**SH:** Pre-tuned synthetic head for cutting sounds with sharp attack  
**NH:** Pre-tuned Napa head creates softer, warmer sound



VR-CAJ-SO



VR-TRICAJ-SO

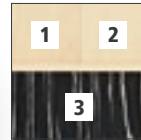

3 DIFFERENT SOUND OPTIONS



VR-CAJ2GO



POPS UP FROM A FLAT PIECE INTO A FULL SIZE CAJON



DEEP BASS TONES

caiXoN  
VR-CAIX

FORWARD FACING SOUND PORT



HIGHER TONES

caiXoNet  
VR-CAIXN



Set  
VR-CAIX/CAIXN



STACKABLE FOR EASY STORAGE AND TRANSPORTATION

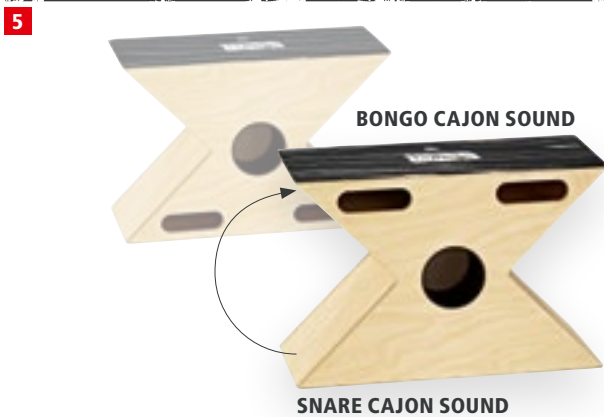

BONGO CAJON SOUND

SNARE CAJON SOUND

VR-XCAJ-SO



CONTRASTING PLAYING SURFACES ON OPPOSITE SIDES

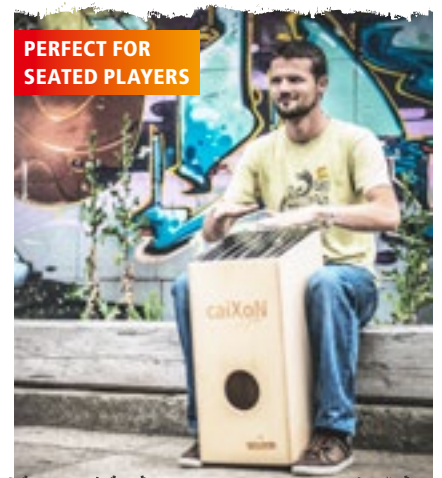

PERFECT FOR SEATED PLAYERS

## 1 SNARE CAJON

**SIZE** 11 3/4" W x 17 3/4" H x 12" D  
**MATERIALS** Resonating body: Baltic Birch (*Betula pendula*)  
Frontplate: Striped Onyx  
**FEATURES** Two internal snare wires  
Birch construction  
Four rubber feet  
Wide sound options

## 2 TRI TONE CAJON

**SIZE** 11 3/4" W x 19 1/2" H x 13" D  
**MATERIALS** Resonating body: Baltic Birch (*Betula pendula*)  
Playing surfaces: Striped Onyx  
**FEATURES** 3 different cajon sound options all in one unit: Bongo cajon (1); Snare cajon (2); Peruvian style cajon (3)  
Two internal snare wires for the snare section

## 3 CAJON2GO

**SIZE** 13 1/2" W x 18" H x 12 1/2" D  
**MATERIAL** Cardboard  
**FEATURES** Folds from a single flat piece into a full size cajon  
Internal fixed set of snare wires  
Comfortably holds up to 150 kg / 330 lbs  
Naturally deep bass and crisp snare sounds

## 4 CAIXON & CAIXONET

**SIZES** **VR-CAIX** (caiXoN)  
11 1/2" W x 26 1/4" H x 12" D  
**VR-CAIXN** (caiXoNet)  
10 1/2" W x 26 1/4" H x 9 1/2" D  
**MATERIALS** Resonating body: Baltic Birch (*Betula pendula*)  
Playing surface: Striped Onyx  
**FEATURES** Internal snare wires for cutting snare slaps

## 5 X-CAJON

**SIZE** 14 1/2" W x 10" H x 5 3/4" D  
**MATERIALS** Resonating body: Baltic Birch (*Betula pendula*)  
Playing surfaces: Striped Onyx  
**FEATURES** Comfortable and unique X-design  
Forward sound projection  
Internal snare wires for a snare cajon sound on one side  
Bongo cajon sound on the opposite side

# HAND PERCUSSION

1



VR-TA2-ROM

2



VR-ABS1



3



RICH TONES

VR-HCB-R

4



Set  
VR-ES2

5



VR-CSH

## 1 WOOD TAMBOURINE

**SIZE** 10" diameter  
**MATERIALS** Black plated steel jingles  
 Siam Oak (*Hevea brasiliensis* Muell.-Arg.)  
**FEATURES** Steel jingles create bright, high pitched sounds  
 Double row  
 Sturdy wooden frame in colourful finish  
 Ergonomic grip  
**FINISH** Red/orange marble

## 2 ABS PLASTIC TAMBOURINE

**SIZE** 8" diameter  
**MATERIALS** Black plated steel jingles  
 ABS plastic

**FEATURES** Steel jingles create bright, high pitched sounds  
 Single row  
 Sturdy ABS plastic frame in a colourful finish  
 Extra wide grip  
**FINISH** Red/orange

## 3 HAND COWBELL

**SIZE** 8" long  
**MATERIALS** Powder coated steel  
 ABS Plastic  
**FEATURES** Muffled, firm sound  
 Handheld  
 Rich tones  
**INCLUDES** Cowbell beater with ribbed grip  
**COLOUR** Red

## 4 EGG SHAKER PAIR

**MATERIAL** Plastic  
**FEATURES** Precise, cutting sound  
 Comes in a set of two  
**COLOUR** Red/orange

## 5 CRYSTAL SHAKER

**SIZE** 8 1/4" long  
**MATERIALS** Plastic  
 Acrylic glass  
**FEATURES** Shapes any groove with clarity and feel  
 Transparent body allows to follow the movement of the filling as an learning effect  
 Perfect for live playing  
**COLOUR** Red/orange

**1** **ADJUSTABLE BACKPACK STRAPS**



VR-DJB-14    VR-DJB-12    VR-DJB-10    VR-DJB-9

**2** **CARRY ALL THREE SIZES OF MEINL VIVARHYTHM® CONGAS**



VR-CSETB

**3** **CARRY ALL THREE SIZES OF MEINL VIVARHYTHM® BASS DRUMS**



VR-BDSETB

**4** **CARRY BOTH SIZES OF MEINL VIVARHYTHM® STACK DRUM SET**



VR-SDSETB

**5** **ADJUSTABLE BACKPACK STRAPS**



VR-TB

**6** **ADJUSTABLE SHOULDER STRAP**



VR-XCAJB

**7** **FITS MOST COMMON CAJON SIZES**



VR-CAJB

**8** **ADJUSTABLE SHOULDER STRAP**



VR-TRICAJB

**9** **FITS CAIXON AND CAIXONET STACKED OR INDIVIDUAL**



VR-CAIXB

HAND PERCUSSION & BAGS

**BAGS**

**MATERIAL** Heavy-duty padded nylon  
**FEATURES** Carrying handle with reinforced nylon stitching; Durable zipper  
**COLOUR** Black

**1 DJEMBE BAGS**

**SIZES** **VR-DJB-9:** 11 1/2" x 17 1/4"  
**VR-DJB-10:** 11 3/4" x 19 3/4"  
**VR-DJB-12:** 13 3/4" x 24 1/2"  
**VR-DJB-14:** 15 3/4" x 27 1/2"

**FEATURES** Adjustable backpack straps  
**VR-DJB-9** Holds 8" & 9" diameter djembes  
**VR-DJB-10** Holds 10" diameter djembes  
**VR-DJB-12** Holds 12" diameter djembes  
**VR-DJB-14** Holds 14" diameter djembes

**2 CONGA SET BAG**

**SIZE** 13" x 26"  
**FEATURES** Adjustable backpack straps  
 Carry all three sizes of MEINL VivaRhythm® Congas

**3 BASS DRUM SET BAG**

**SIZE** 16 1/4" x 25 1/4"  
**FEATURES** Adjustable backpack straps  
 Carry all three sizes of MEINL VivaRhythm® Bass Drums

**4 STACK DRUM SET BAG**

**SIZE** 13 1/2" x 24 1/2"  
**FEATURES** Adjustable backpack straps  
 Carry both sizes of MEINL VivaRhythm® Stack Drum Set

**5 TIMBA BAG**

**SIZE** 13 1/2" x 29"

**FEATURE** Adjustable backpack straps

**6 X-CAJON BAG**

**SIZE** 18 1/4" W x 13 1/2" H x 8" D  
**FEATURE** Adjustable shoulder strap

**7 CAJON BAG**

**SIZE** 20 1/2" W x 13 1/2" H x 12" D  
**FEATURE** Fits most common cajon sizes

**8 TRI TONE CAJON BAG**

**SIZE** 21" W x 13" H x 13 1/2" D  
**FEATURE** Adjustable shoulder strap

**9 CAIXON & CAIXONET BAG**

**SIZE** 31" W x 12 1/2" H x 13 1/2" D  
**FEATURES** Adjustable shoulder strap  
 Fits caiXoN and caiXoNet stacked or individual



**Learning to play an instrument and making music are life-changing things to do, especially for children.**

Starting this in early childhood nurtures many things including perception, motor skills and the ability to learn and retain information. Making music also promotes personal confidence and social skills. These are all beneficial well beyond one's childhood years.

NINO® Percussion offers an outstanding collection of musical instruments designed specifically for children. These more than meet the requirements of early childhood music education and are ideal for kindergarten and school programs, or for music therapy and other music-making activities.

It is important to know that NINO® Percussion instruments are not toys. These are the real thing, designed for safety, durability, attractiveness and playability. Most importantly, they are in tune and musical. In fact, the only difference between NINO® Percussion instruments and those created for adults is their size and colour.

These appealing and pleasing designs are of a very high quality and include a wide variety of sound choices, making them popular with young players, as well as teachers and parents. Whether played alone or with a group, the performance and sound quality of NINO® Percussion instruments make them the ideal choice for young musicians and those who teach them.



<b>Classroom Percussion</b>	<b>02-03</b>	Wood Frame Drums	<b>11</b>
<b>Cajons</b>	<b>04-05</b>	<b>Tambourines</b>	<b>12</b>
<b>Djembes</b>	<b>06-07</b>	<b>Rhythm Sets</b>	<b>13</b>
Synthetic & ABS Djembes	<b>06</b>	<b>Shakers</b>	<b>14-16</b>
Wood Djembes	<b>07</b>	Egg Shakers	<b>14</b>
<b>Bongos</b>	<b>08</b>	"Fruit & Vegetable" Shakers	<b>15</b>
<b>Congas</b>	<b>09</b>	<b>Maracas</b>	<b>17</b>
<b>Frame Drums</b>	<b>10-11</b>	<b>Hand Percussion</b>	<b>18-21</b>
ABS Frame Drums	<b>10</b>	<b>Cymbals</b>	<b>22</b>

# CLASSROOM PERCUSSION

1

3+



NINO954

2

3+



NINO954-2

3

3+



NINO957

4

3+

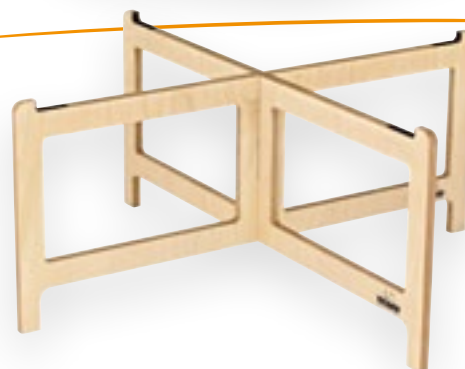

NINO958

5

3+



Set, 8 pcs.  
NINO959

## 1 CLASSROOM CAJON

**SIZE** 34" diameter  
**MATERIAL** Baltic Birch (*Betula*)  
**FEATURES** Eight individual cajons connected in one unit  
 Multi-coloured playing surfaces  
 Ultimate drum circle experience  
 Internal snare wires  
**COLOUR** Multi-colour

## 2 DELUXE CLASSROOM CAJON

**SIZE** 36" diameter  
**MATERIAL** Baltic Birch (*Betula*)  
**FEATURES** Eight separate cajons  
 Birch wood baseplate to hold the cajons together  
 Great for easy storage  
 Ultimate drum circle experience  
 Internal snare wires  
**COLOUR** Multi-colour

## 3 WOODEN CLASSROOM CAJON STAND

**SIZE** 34.5" diameter  
**MATERIAL** Baltic Birch (*Betula*)  
**FEATURES** Two piece assembly  
 Designed for the NINO® Classroom cajon (NINO954)  
 Protective corners to keep from scratching  
**COLOUR** Natural

## 4 WOODEN DELUXE CLASSROOM CAJON STAND

**SIZE** 36.5" diameter  
**MATERIAL** Baltic Birch (*Betula*)  
**FEATURES** Two piece assembly  
 Designed for the NINO® Deluxe Classroom cajon (NINO954-2)  
 Protective corners to keep from scratching  
**COLOUR** Natural



6 **NEW** 3+



NINO965

7 3+



**NEW**

NINO966



**5 CLASSROOM CAJON STOOLS**

**SIZE** 12.5" height  
**MATERIAL** Baltic Birch (*Betula*)  
**FEATURES** Eight stools for the NINO® Classroom Cajons and NINO® Classroom Hand Drum Set with Stand  
 Perfect height to play the NINO® Classroom cajon when it's placed on a stand  
**COLOUR** Multi-colour

**6 HAND DRUM PAIR WITH STAND**

**SIZE** 23 1/4" W x 12" H x 14" D  
**MATERIALS** Hand drums: ABS plastic  
 Stand: Baltic Birch (*Betula*)  
**FEATURES** Hand drum pair with wooden stand  
 Durable synthetic drums produce high and low notes  
 Perfect for encouraging growth in music  
 Easy to assemble and tear down for storage  
**INCLUDES** One pair of wooden beaters

**7 CLASSROOM HAND DRUM SET WITH STAND**

**SIZE** 36" diameter  
**MATERIALS** Hand drums: ABS plastic  
 Stand: Baltic Birch (*Betula*)  
**FEATURES** Four durable synthetic hand drum pairs that produce high and low notes  
 One large central drum for everyone to play at once  
 The ultimate drum circle experience for young musicians  
 Encourages group participation in classrooms  
 Easy to assemble and tear down for storage  
**INCLUDES** Wooden stand  
 Four pairs of wooden beaters

# CAJONS

1

4+



Blue  
NINO950B



Green  
NINO950GR



Yellow  
NINO950Y



Orange  
NINO950OR



Red  
NINO950R

10+

2  
NEW

10+



Natural  
NINO950

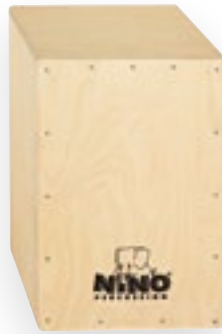

Natural  
NINO952

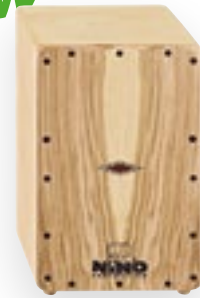

White Oak  
AE-NINO951

3

10+

4

3+



Grey  
NINO952GY



Salmon  
NINO952SA



Turquoise  
NINO952TU



Dark Green  
NINO951DG

## 1 CAJONS

**SIZE** NINO950  
9 3/4" W x 13" H x 9 1/2" D  
NINO952  
12" W x 17 3/4" H x 11 3/4" D

**MATERIALS** Frontplate: Baltic Birch (*Betula*)  
Resonating Body: Baltic Birch (*Betula*)

**FEATURES** Internal snare wires  
Adjustable top corners

**COLOURS** B: Blue  
GR: Green  
OR: Orange  
R: Red  
Y: Yellow

## 2 ARTISAN EDITION CAJON, NINO LINE

**SIZE** 9" W x 14 3/4" H x 9 1/2" D

**MATERIALS** Frontplate: White Oak  
Resonating Body: Baltic Birch (*Betula*)

**FEATURES** 8 pre-tuned internal metal strings for a sensitive snare effect  
Baltic Birch resonating body with rear port  
Made in Spain

## 3 BETTER LIFE SERIES CAJONS

**SIZE** 12" W x 17 3/4" H x 11 3/4" D

**MATERIALS** Frontplate: Baltic Birch (*Betula*)  
Resonating Body: Baltic Birch (*Betula*)

**FEATURES** Internal snare wires  
Adjustable top corners

**COLOURS** GY: Grey  
SA: Salmon  
TU: Turquoise

## 4 CHALKBOARD CAJON

**SIZE** 10 1/4" W x 15" H x 10 1/4" D

**MATERIAL** Baltic Birch (*Betula*)

**FEATURES** Internal snare wires  
Adjustable top corners  
Great to learn fundamentals of rhythm  
Customizable frontplate

**INCLUDES** Chalk pack, 7 different colours

**COLOUR** DG: Dark Green

## 5 BONGO CAJONS

**SIZE** 12" W x 5 1/2" H x 5" D

**MATERIAL** Baltic Birch (*Betula*)

**FEATURE** High and low pitch playing surface

**COLOURS** GR: Green  
R: Red

5

3+



Natural  
NINO931



Green  
NINO931GR



Red  
NINO931R

6

4+



Natural  
NINO953

7

5+



Natural  
NINO951-MYO

8

5+



Dark Green  
NINO951DG-MYO



CAJONS

**6 SLAPTOP CAJON**

**SIZE** 15" W x 8" H x 7.5" D  
**MATERIAL** Baltic Birch (*Betula*)  
**FEATURES** Low and high notes for various beat combinations  
 Internal snare wires  
 Forward facing sound ports  
 Sits comfortably in the lap  
**COLOUR** Natural

1 x rear panel  
 1 x playing surface (with NINO® logo)  
 2 x side battens  
 1 x base & 1 x top batten  
 1 x securing batten for the snare  
 1 x snare  
 4 x rubber feet  
 15 x screws, 3 x 20 mm (for playing surface)  
 4 x screws, 4 x 15 mm (for rubber feet)  
 2 x screws, 3 x 12 mm (for snare)

**CONTAINS** 1 x assembly instructions in nine languages  
 2 x side panels  
 1 x base panel  
 1 x top panel  
 1 x rear panel  
 1 x snare  
 2 x side battens  
 1 x base & 1 x top batten  
 1 x securing batten for the snare  
 1 x snare  
 4 x rubber feet

**7 MAKE YOUR OWN CAJON**

**SIZE** 10.25" W x 15" H x 10.25" D  
**MATERIALS** Resonating Body: Baltic Birch (*Betula*)  
 Frontplate: Baltic Birch (*Betula*)  
**FEATURES** Internal snare wires  
 Includes stencil designs  
**CONTAINS** 1 x assembly instructions in nine languages  
 2 x side panels  
 1 x base panel  
 1 x top panel

**COLOUR** Natural

**8 MAKE YOUR OWN CHALKBOARD CAJON**

**SIZE** 10.25" W x 15" H x 10.25" D  
**MATERIALS** Resonating Body: Baltic Birch (*Betula*)  
 Frontplate: Baltic Birch (*Betula*)  
**FEATURES** Internal snare wires  
 Includes stencil designs

**CONTAINS** 1 x assembly instructions in nine languages  
 4 x screws, 4 x 15 mm (for rubber feet)  
 2 x screws, 3 x 12 mm (for snare)  
**NINO951DG-MYO**  
 1 x customizable face with NINO® logo  
 1 x pack of chalk, 7 different colours  
**COLOUR** **DG:** Dark Green

# SYNTHETIC & ABS DJEMBEES

1



3+



2

5+



Red/Black  
NINO18R/BK

Green/Yellow  
NINO18G/Y

3

5+



Sunshine, 10"  
NINO-PDJ1-M-F

Sunshine, 10"  
NINO-PDJ1-M-G

4+



Sunshine, 8"  
NINO-PDJ1-S-F

Sunshine, 8"  
NINO-PDJ1-S-G

## 1 ELEMENTS MINI DJEMBEES

**SIZE** 6" diameter, 10 1/2" tall  
**MATERIALS** Synthetic shell  
 Plastic head  
**FEATURES** 100% plastic head and shell is perfect for outdoor playing  
 Ultra light weight makes them easy to carry  
 Compact size  
**COLOURS** **BB:** Blueberry  
**BG:** Bubble Gum  
**CM:** Copper Metallic  
**FB:** Flat Black  
**FE:** Fire Engine  
**GA:** Green Apple  
**GM:** Gold Metallic  
**GP:** Grape  
**KQ:** Kenyan Quilt  
**LE:** Lemon  
**PS:** Pharaoh's Script  
**SF:** Sea Foam

**SM:** Silver Metallic  
**SN:** Snow  
**SU:** Sunshine  
**T:** Tangerine  
**TA:** Twisted Amber

## 2 ABS DJEMBEES

**SIZE** 8" diameter, 13 3/4" tall  
**MATERIALS** ABS plastic  
 Synthetic heads  
**INCLUDES** Nylon strap  
**COLOURS** **G/Y:** Green/Yellow  
**R/BK:** Red/Black

## 3 ROPE TUNED SYNTHETIC DJEMBEES

**SIZES** **S:** 8" diameter, 16" tall  
**M:** 10" diameter, 21" tall  
**MATERIALS** Synthetic shell  
**F:** Synthetic head  
**G:** Hand selected goatskin head  
**PP ROPE** 4 mm thickness, 30 runners  
**FEATURES** 100% synthetic shell are perfect for outdoor playing  
 Ultra light weight makes them easy to carry  
 High quality PP nylon ropes  
 Produces sharp slaps and deep bass tones  
 Non-slip rubber bottom  
**FINISH** Sunshine

# WOOD DJEMBES



1 **4+** **3+** **4+** **3+**

EARTH RHYTHM SERIES



8" NINO-ADJ3-S      7" NINO-ADJ3-XS      4 1/2" NINO-ADJ3-XXS

WATER RHYTHM SERIES



8" NINO-ADJ2-S      7" NINO-ADJ2-XS      4 1/2" NINO-ADJ2-XXS

MOON RHYTHM SERIES



8" NINO-ADJ4-S      7" NINO-ADJ4-XS      4 1/2" NINO-ADJ4-XXS

2 **5+**



10" NINO48NT

DJEMBES

## 1 ORIGINAL AFRICAN STYLE ROPE TUNED WOOD DJEMBES

- SIZES** **XXS:** 4 1/2" diameter, 8" tall  
**XS:** 7" diameter, 11 3/4" tall  
**S:** 8" diameter, 15 3/4" tall
- MATERIALS** Mahogany Wood  
Hand selected goatskin heads
- PP ROPES** **XXS:** 3 mm thickness, 10 runners  
**XS:** 3 mm thickness, 20 runners  
**S:** 4 mm thickness, 20 runners
- FEATURES** Carved from one solid piece of plantation grown Mahogany Wood  
High quality PP nylon ropes  
Hand carved shells
- COLOURS** **ADJ2:** Brown (Water Rhythm Series)  
**ADJ3:** Brown/Black (Earth Rhythm Series)  
**ADJ4:** Black (Moon Rhythm Series)

## 2 WOOD DJEMBE

- SIZE** 10" diameter, 21" tall
- MATERIALS** Siam Oak (*Hevea brasiliensis* Muell.-Arg.)  
Hand selected goatskin head
- FEATURES** Rounded rim for playing comfort  
Black powder coated hardware
- INCLUDES** Tuning key
- COLOUR** **N:** Natural



# BONGOS

1 4+



Green/Yellow  
NINO19G/Y

2 5+



Blue  
NINO17B-BK



Yellow  
NINO17Y-BK



Red  
NINO19R



Red  
NINO17R-BK

3 5+



Natural/Black  
NINO3NT-BK



4 5+



Natural/Harlekin  
NINO3NT-HK



NINO20

## 1 ABS BONGOS

**SIZES** 6 1/2" Macho & 7 1/2" Hembra  
**MATERIALS** ABS plastic  
Synthetic heads  
**COLOURS** **G/Y:** Green/Yellow  
**R:** Red

## 2 ABS BONGOS PLUS

**SIZES** 6 1/2" Macho & 7 1/2" Hembra  
**MATERIALS** ABS plastic  
Hand selected buffalo heads  
**FEATURES** Rounded rims for playing comfort  
Black powder coated hardware  
**INCLUDES** Tuning key  
**COLOURS** **B-BK:** Blue Shell / Black Hardware  
**R-BK:** Red Shell / Black Hardware  
**Y-BK:** Yellow Shell / Black Hardware

## 3 WOOD BONGOS

**SIZES** 6 1/2" Macho & 7 1/2" Hembra  
**MATERIALS** Siam Oak (*Hevea brasiliensis* Muell.-Arg.)  
Hand selected buffalo heads  
**FEATURES** Fully rounded rims for playing comfort  
**INCLUDES** Tuning key  
**COLOURS** **NT-BK:** Natural Shell / Black Hardware  
**NT-HK:** Natural Shell / Harlekin Hardware

## 4 BONGO STAND

**MATERIAL** Chrome plated steel  
**FEATURES** Fully height adjustable from 31" to 45"  
90° angle adjustable  
Tripod stand with rubber feet  
Suitable for other common bongo models



# CONGAS



1

5+

2

8+



8" & 9"  
NINO89NT

9" & 10"  
NINO910NT

## 1 NINO89 WOOD CONGA SET

- SIZES** 8" & 9" head diameter, 22" tall
- MATERIALS** Siam Oak (*Hevea brasiliensis* Muell.-Arg.)  
Hand selected buffalo heads
- FEATURES** Rounded rims for playing comfort  
Black powder coated hardware
- INCLUDES** Basket stands  
Tuning key
- COLOUR** **NT:** Natural

## 2 NINO910 WOOD CONGA SET

- SIZES** 9" & 10" head diameter, 28" tall
- MATERIALS** Siam Oak (*Hevea brasiliensis* Muell.-Arg.)  
Hand selected buffalo heads
- FEATURES** Rounded rims for playing comfort  
Black powder coated hardware
- INCLUDES** Height adjustable basket stands with  
quick set up system  
Tuning key
- COLOUR** **NT:** Natural



BONGOS & CONGAS

# ABS FRAME DRUMS

1



Sky Blue **NINO4SB** Grass Green **NINO4GG** Yellow **NINO4Y** Red **NINO4R** Strawberry Pink **NINO4SP**

3+



Sky Blue **NINO45SB** Grass Green **NINO45GG** Yellow **NINO45Y** Red **NINO45R** Strawberry Pink **NINO45SP**



Sky Blue **NINO5SB** Grass Green **NINO5GG** Yellow **NINO5Y** Red **NINO5R**

5+



Sky Blue **NINO6SB** Grass Green **NINO6GG** Yellow **NINO6Y** Red **NINO6R**

2



Set, 5 pcs. **NINOSET6**

3+

3



Yellow **NINO5OW** Red **NINO5FT**

5+

## 1 ABS HAND DRUMS

**SIZES** **NINO4:** 6" diameter  
**NINO45:** 8" diameter  
**NINO5:** 10" diameter  
**NINO6:** 12" diameter

**MATERIALS** ABS plastic frame  
Synthetic head

**INCLUDES** Wooden beater

**COLOURS** **GG:** Grass Green  
**R:** Red  
**SB:** Sky Blue  
**SP:** Strawberry Pink  
**Y:** Yellow

## 2 ABS HAND DRUM SET

**CONTAINS** 1 x ABS Hand Drum 6" (NINO4Y)  
1 x ABS Hand Drum 8" (NINO45SB)  
1 x ABS Hand Drum 10" (NINO5GG)  
1 x ABS Hand Drum 12" (NINO6R)

**INCLUDES** 4 x Wooden beater  
1 x Red nylon bag

## 3 CUSTOMIZABLE ABS HAND DRUMS

**SIZE** 10" diameter

**MATERIALS** ABS plastic frame  
Synthetic head

**INCLUDES** Wooden beater  
Pack of safe to use coloured markers

**COLOURS** **FT:** Red (Fire Truck Graphic)  
**OW:** Yellow (Owl Graphic)





# WOOD FRAME DRUMS



FRAME DRUMS

## 1 SEA DRUMS

**SIZES** NINO44: 8" diameter  
NINO34: 10" diameter  
NINO35: 12" diameter  
NINO30: 14" diameter

**MATERIALS** Siam Oak frame  
(*Hevea brasiliensis* Muell.-Arg.)  
Two clear synthetic heads

**FEATURE** Soothing sounds

## 2 WOOD HAND DRUMS

**SIZES** NINO43: 8" diameter  
NINO27: 10" diameter  
NINO28: 12" diameter

**MATERIALS** Wooden frame  
Synthetic head

## 3 HAND DRUMS WITH HANDLE

**SIZES** NINO42: 8" diameter  
NINO32: 10" diameter

**MATERIALS** Wooden frame and handle  
Synthetic head

**FEATURE** Ergonomically shaped wooden handle

## 4 TUNABLE HAND DRUMS WITH TRUE FEEL SYNTHETIC HEAD

**SIZES** NINO38: 10" diameter  
NINO39: 12" diameter

**MATERIALS** Wooden frame  
True Feel synthetic head

**FEATURES** Countersunk bolt lugs  
Chrome plated hardware  
Replaceable True Feel synthetic head

**INCLUDES** Tuning key

## 5 TUNABLE HAND DRUMS WITH GOATSKIN HEAD

**SIZES** NINO36: 10" diameter  
NINO37: 12" diameter

**MATERIALS** Wooden frame  
Hand selected goatskin head

**FEATURES** Countersunk bolt lugs  
Chrome plated hardware  
Replaceable hand selected goatskin head

**INCLUDES** Tuning key

# TAMBOURINES



Sky Blue **NINO51SB** Grass Green **NINO51GG** Yellow **NINO51Y** Red **NINO51R** Strawberry Pink **NINO51SP**



Sky Blue **NINO24SB** Grass Green **NINO24GG** Yellow **NINO24Y** Red **NINO24R**

5+



Sky Blue **NINO49SB** Grass Green **NINO49GG** Yellow **NINO49Y** Red **NINO49R** Strawberry Pink **NINO49SP**

3+



1 row, 10" **NINO25** 2 rows, 10" **NINO26** 1 row, 8" **NINO47**

5+

3+



1 row, 10" **NINO14** 2 rows, 10" **NINO15** 1 row, 8" **NINO46** 2 rows, 8" **NINO50**

5+

3+

## 1 ABS TAMBOURINES

**SIZES** **NINO51**: 8" diameter  
**NINO24**: 10" diameter  
**MATERIALS** ABS plastic frame  
Synthetic head  
Nickel Silver plated steel jingles  
**INCLUDES** Wooden beater  
**COLOURS** **GG**: Grass Green  
**R**: Red  
**SB**: Sky Blue  
**SP**: Strawberry Pink  
**Y**: Yellow

## 2 COMPACT ABS TAMBOURINES

**SIZE** 8" diameter  
**MATERIALS** ABS plastic frame  
Stainless steel jingles  
**FEATURES** Extra wide grip  
Bright, cutting sound  
Durable frame  
1 row version  
Compact size  
**COLOURS** **GG**: Grass Green  
**R**: Red  
**SB**: Sky Blue  
**SP**: Strawberry Pink  
**Y**: Yellow

## 3 HEADED WOOD TAMBOURINES

**SIZES** **NINO47**: 8" diameter  
**NINO25**, **NINO26**: 10" diameter  
**MATERIALS** Wooden frame  
Synthetic head  
Nickel Silver plated steel jingles  
**FEATURES** **NINO25**, **NINO47**: 1 row version  
**NINO26**: 2 row version  
**INCLUDES** Wooden beater

## 4 WOOD TAMBOURINES

**SIZES** **NINO46**, **NINO50**: 8" diameter  
**NINO14**, **NINO15**: 10" diameter  
**MATERIALS** Wooden frame  
Nickel Silver plated steel jingles  
**FEATURES** **NINO14**, **NINO46**: 1 row version  
**NINO15**, **NINO50**: 2 row version

# RHYTHM SETS



1



Set, 4 pcs.  
**NINOSET2**



3+

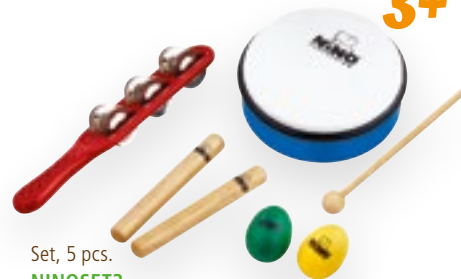

Set, 5 pcs.  
**NINOSET3**



Set, 5 pcs.  
**NINOSET1**



Set, 8 pcs.  
**NINOSET4**



2

3+

Set, 12 pcs.  
**NINOSET012**



Set, 12 pcs.  
**NINOSET012-WB**



3

3+

Set, 15 pcs.  
**NINOSET515**



Set, 15 pcs.  
**NINOSET515-WB**



TAMBOURINES & RHYTHM SETS

## 1 RHYTHM SETS

### CONTAINS **NINOSET1**

- 1 x ABS Hand Drum, 6" (NINO4R)
- 1 x Wood Shaker, large (NINO2)
- 2 x Skin Maraca, small (pair) (NINO10)
- 1 x Jingle Stick (NINO13R)

### **NINOSET2**

- 1 x Jingle Stick (NINO13R)
- 1 x Wood Claves pair, small (NINO502)
- 1 x Egg Shaker (NINO540LB)
- 1 x Egg Shaker (NINO540LY)

### **NINOSET3**

- 1 x ABS Hand Drum, 6" (NINO4B)
- 1 x Jingle Stick (NINO13R)
- 1 x Wood Claves pair, small (NINO502)
- 1 x Egg Shaker (NINO540LGR)
- 1 x Egg Shaker (NINO540LY)

### **NINOSET4**

- 1 x Wood Güiro (NINO555)
- 1 x Caxixi (NINO501)

- 1 x Wood Claves pair, small (NINO502)
- 1 x Triangle, 4" (NINO550)
- 1 x Egg Shaker (NINO540LB)
- 1 x Egg Shaker (NINO540LBK)
- 1 x "Banana" Shaker (NINO597)
- 1 x "Apple" Shaker (NINO596)

### INCLUDES **NINOSET1, NINOSET4:** Harlekin bag

## 2 RHYTHM ASSORTMENT 12 PCS.

### CONTAINS **NINOSET012, NINOSET012-WB**

- 1 x ABS Hand Drum, 12" (NINO65B)
- 1 x ABS Tambourine, 10" (NINO24R)
- 1 x ABS Hand Drum, 8" (NINO45GG)
- 1 x ABS Hand Drum, 6" (NINO4Y)
- 2 x Skin Maraca, small (pair) (NINO10)
- 1 x Wood Block, large (NINO22)
- 1 x Skin Egg Shaker (NINO11)
- 1 x Jingle Stick, yellow (NINO13Y)
- 1 x Jingle Stick, red (NINO13R)
- 1 x Wood Tambourine, 10" (NINO14)

### INCLUDES **NINOSET012-WB:** Wooden Box, big

## 3 RHYTHM ASSORTMENT 15 PCS.

### CONTAINS **NINOSET515, NINOSET515-WB**

- 1 x Wood Güiro (NINO555)
- 1 x Triangle, 6" (NINO551)
- 2 x Plastic Egg Maraca, red (NINO569R)
- 1 x Mini Güiro (NINO581R)
- 1 x Egg Shaker (NINO540LY)
- 1 x Racket Tambourine (NINO518)
- 1 x Wood Claves pair, small (NINO502)
- 1 x Energy Chimes, medium (NINO579M)
- 1 x Wood A-Go-Go, 2 rows (NINO560)
- 1 x Double Shaker (NINO503)
- 1 x Wood Shaker Assortment 3 pcs., triangular (NINO508)
- 1 x "Banana" Shaker (NINO597)

### INCLUDES **NINOSET515:** Basket **NINOSET515-WB:** Wooden Box, small

# EGG SHAKERS



NINO11

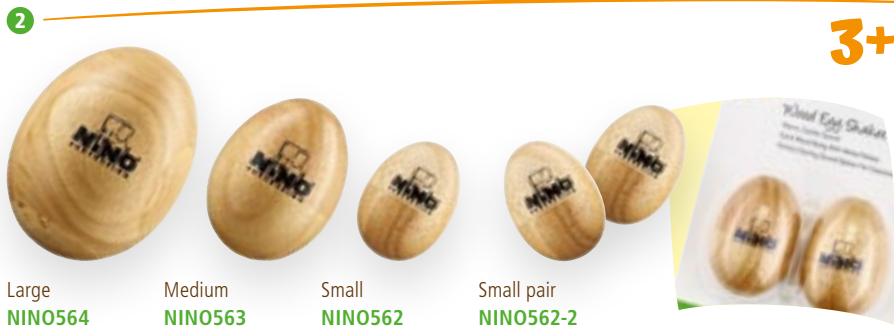

Large  
NINO564

Medium  
NINO563

Small  
NINO562

Small pair  
NINO562-2



Aubergine  
NINO540AU-2

Sky Blue  
NINO540SB-2

Grass Green  
NINO540GG-2

Yellow  
NINO540Y-2

Orange  
NINO540OR-2

Red  
NINO540R-2

Strawberry Pink  
NINO540SP-2

Black  
NINO540BK-2

Transparent  
NINO540T-2



Set, 4 pcs.  
NINOSET540



Set, 4 pcs.  
NINOSET540-2

Set, 80 pcs.  
VE80-NINO540

Set, 80 pcs.  
VE80-NI540-2

## 1 RAWHIDE EGG SHAKER

MATERIAL Natural rawhide

## 2 WOOD EGG SHAKERS

SIZES NINO562: Small  
NINO563: Medium  
NINO564: Large

MATERIAL Siam Oak (*Hevea brasiliensis* Muell.-Arg.)

FEATURE NINO562-2: Sold in pairs

## 3 EGG SHAKER PAIRS

MATERIAL Plastic

FEATURE Sold in pairs

COLOURS AU: Aubergine

BK: Black

GG: Grass Green

OR: Orange

R: Red

SB: Sky Blue

SP: Strawberry Pink

T: Transparent

Y: Yellow

## 4 EGG SHAKER ASSORTMENTS 4 PCS.

MATERIAL Plastic

CONTAINS NINOSET540

1 x Egg Shaker, Blue (B)

1 x Egg Shaker, Green (GR)

1 x Egg Shaker, Red (R)

1 x Egg Shaker, Yellow (Y)

NINOSET540-2

1 x Egg Shaker, Aubergine (AU)

1 x Egg Shaker, Grass Green (GG)

1 x Egg Shaker, Orange (OR)

1 x Egg Shaker, Sky Blue (SB)

## 5 EGG SHAKER ASSORTMENTS 80 PCS.

MATERIAL Plastic

CONTAINS VE80-NINO540

25 x Egg Shaker, Black (BK)

15 x Egg Shaker, Blue (B)

10 x Egg Shaker, Green (GR)

15 x Egg Shaker, Red (R)

15 x Egg Shaker, Yellow (Y)

VE80-NI540-2

10 x Egg Shaker, Aubergine (AU)

10 x Egg Shaker, Black (BK)

10 x Egg Shaker, Grass Green (GG)

10 x Egg Shaker, Orange (OR)

10 x Egg Shaker, Red (R)

10 x Egg Shaker, Sky Blue (SB)

10 x Egg Shaker, Strawberry Pink (SP)

10 x Egg Shaker, Yellow (Y)

INCLUDES 1 x Elephant shaped rattan basket

# "FRUIT & VEGETABLE" SHAKERS

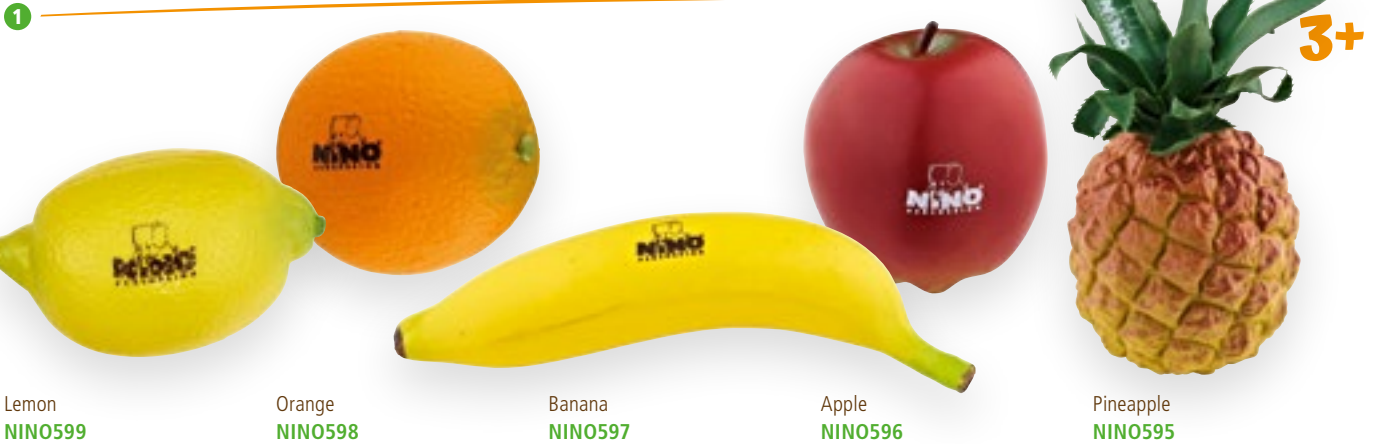

Lemon  
NINO599

Orange  
NINO598

Banana  
NINO597

Apple  
NINO596

Pineapple  
NINO595



Set, 4 pcs.  
NINOSET100



Set, 4 pcs.  
NINOSET101



Set, 36 pcs.  
VE36-NINO536

SHAKERS

## 1 "FRUIT" SHAKERS

**MATERIAL** Plastic  
**FRUITS** NINO595: Pineapple  
NINO596: Apple  
NINO597: Banana  
NINO598: Orange  
NINO599: Lemon

## 2 "FRUIT" SHAKER ASSORTMENT 4 PCS.

**MATERIAL** Plastic  
**CONTAINS** 1 x "Fruit" Shaker, Apple  
1 x "Fruit" Shaker, Banana  
1 x "Fruit" Shaker, Lemon  
1 x "Fruit" Shaker, Orange

## 3 "VEGETABLE" SHAKER ASSORTMENT 4 PCS.

**MATERIAL** Plastic  
**CONTAINS** 1 x "Vegetable" Shaker, Carrot  
1 x "Vegetable" Shaker, Cucumber  
1 x "Vegetable" Shaker, Eggplant  
1 x "Vegetable" Shaker, Pepper

## 4 "FRUIT & VEGETABLE" SHAKER ASSORTMENT 36 PCS.

**MATERIAL** Plastic  
**CONTAINS** Two sets, each 18 pcs.:  
10 x "Fruit" Shaker, Banana  
4 x "Fruit" Shaker, Apple  
4 x "Fruit" Shaker, Orange  
2 x "Fruit" Shaker, Lemon  
2 x "Fruit" Shaker, Mandarin  
2 x "Fruit" Shaker, Pear  
2 x "Fruit" Shaker, Pineapple  
2 x "Vegetable" Shaker, Cabbage  
2 x "Vegetable" Shaker, Carrot  
2 x "Vegetable" Shaker, Cucumber  
2 x "Vegetable" Shaker, Eggplant  
2 x "Vegetable" Shaker, Pepper  
**INCLUDES** 2 x Rattan basket

# SHAKERS

1



NINO526



Shake the pieces and find a pair that sounds the same!  
The photos on the bottom show you if they are correct.

3+

2



NINO956

3+

3



3+

4



NINO501

3+

5



3+

6



Set, 2 pcs.  
NINO578

3+

7



3+

8



3+

9



3+

NINO577

## 1 SHAKE 'N PLAY

**MATERIALS** Plastic shakers  
Siam Oak baseplate  
(*Hevea brasiliensis* Muell.-Arg.)  
**CONTAINS** 16 shakers (8 pairs)  
Wooden baseplate  
Game guide (in 8 languages)  
**COLOUR** Orange

**COLOURS** B: Blue  
GR: Green  
OR: Orange  
R: Red

## 2 SCHOOL BUS SHAKER

**SIZE** 5 1/2" long  
**MATERIAL** Baltic Birch (*Betula pendula*)  
**FEATURES** Comfortable to hold and easy to play  
Familiar and fun school bus design  
Powerful shaker sound

## 4 CAXIXI

**MATERIAL** Rattan with natural hide bottom

## 3 RATTLE STICKS

**SIZE** 7" tall  
**MATERIAL** Siam Oak (*Hevea brasiliensis* Muell.-Arg.)  
**FEATURE** Sold in pairs

## 5 WOOD SHAKERS

**SHAPES** NINO1: Cylindrical, small  
NINO2: Cylindrical, large  
NINO507: Square, 3 pcs. set  
NINO508: Triangular, 3 pcs. set  
**MATERIAL** Siam Oak (*Hevea brasiliensis* Muell.-Arg.)  
**FEATURE** Different sounding fillings

## 7 MINI CAJON SHAKERS

**MATERIAL** Baltic Birch (*Betula pendula*)  
**FEATURES** Compact size  
Cutting shaker sound  
Miniature size of a NINO® cajon  
**COLOURS** B: Blue  
GR: Green  
R: Red

## 8 BALL SHAKER

**MATERIAL** Plastic  
**FEATURE** Attractive Harlekin design

## 9 DOUBLE SHAKER

**SIZE** 6"  
**MATERIAL** Plastic  
**FEATURE** Ergonomically shaped handle  
One-handed playable

# MARACAS



Sky Blue  
NINO569SB

Grass Green  
NINO569GG



Orange  
NINO569OR



Red  
NINO569R



Set, 48 pcs.  
VE48-NINO569



NINO565



Green  
NINO582GR

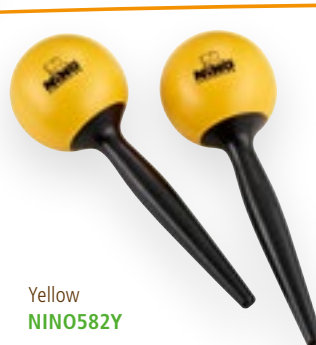

Yellow  
NINO582Y



Red  
NINO582R



Red  
NINO8PD-R

Blue  
NINO7PD-B



NINO8

NINO7



NINO10

## 1 PLASTIC EGG MARACAS

**SIZE** 6"  
**MATERIAL** Plastic  
**FEATURES** Ergonomically shaped handle  
Sold in pairs  
**COLOURS** **GG:** Grass Green  
**OR:** Orange  
**R:** Red  
**SB:** Sky Blue

## 2 PLASTIC EGG MARACAS ASSORTMENT 48 PCS.

**MATERIAL** Plastic  
**CONTAINS** 12 x Plastic Egg Maraca, Grass Green (GG)  
12 x Plastic Egg Maraca, Orange (OR)  
12 x Plastic Egg Maraca, Red (R)  
12 x Plastic Egg Maraca, Sky Blue (SB)  
**INCLUDES** 1 x Rattan basket

## 3 WOOD EGG MARACAS

**SIZE** Small  
**MATERIAL** Siam Oak (*Hevea brasiliensis* Muell.-Arg.)  
**FEATURES** Ergonomically shaped handle  
Sold in pairs

## 4 PLASTIC MARACAS

**MATERIAL** Plastic  
**FEATURES** Ergonomically shaped handle  
Sold in pairs  
**COLOURS** **GR:** Green  
**R:** Red  
**Y:** Yellow

## 5 WOOD MARACAS

**SIZES** **NINO7, NINO7PD-B:** Small  
**NINO8, NINO8PD-R:** Medium  
**MATERIAL** Siam Oak (*Hevea brasiliensis* Muell.-Arg.)  
**FEATURES** Ergonomically shaped handle  
Sold in pairs  
**COLOURS** **PD-B:** Blue with white polka dots  
**PD-R:** Red with white polka dots

## 6 RAWHIDE MARACAS

**SIZE** Small  
**MATERIAL** Natural rawhide  
**FEATURES** Mellow sound  
Ergonomically shaped wood handle  
Sold in pairs

# HAND PERCUSSION



## 1 SAND BLOCKS

**MATERIAL** Pine Wood (*Pinus Radiata*)  
**FEATURES** Sold in pairs  
 Unique sounds  
**COLOURS** B: Blue  
 GR: Green  
 R: Red

## 2 SYNTHETIC RAINSTICKS

**SIZES** NINO-SRS1-M: 18"  
 NINO-SRS1-L: 24"  
**MATERIAL** Lightweight synthetic  
**FINISH** Sunshine

## 3 WOOD RAINMAKER

**SIZE** 12" long  
**MATERIAL** Baltic Birch (*Betula Pendula*)  
**FEATURES** Birch wood construction with rounded corners  
 Authentic rain sounds with a long sustain

## 4 WOOD HAND CASTANET

**MATERIAL** Siam Oak (*Hevea brasiliensis* Muell.-Arg.)  
**FEATURE** Attractive shape

## 5 WOODPECKER

**MATERIAL** Siam Oak (*Hevea brasiliensis* Muell.-Arg.)

## 6 WOOD FROG GÜIROS

**SIZES** NIN0517: X-Small 2 1/4"  
 NIN0513GR: Small 4"  
 NIN0514GR: Medium 5"  
 NIN0515GR: Large 5 1/2"  
 NIN0516GR: X-Large 8 1/2"

**MATERIAL** Wood  
**FEATURE** Creates original "ribbit" sound  
**INCLUDES** Wooden scraper  
**COLOUR** GR: Green

## 7 MINI GÜIROS

**SIZE** Mini  
**INCLUDES** Wooden scraper  
**COLOUR** BK: Black  
 R: Red

## 8 WOOD GÜIRO

**MATERIAL** Siam Oak (*Hevea brasiliensis* Muell.-Arg.)  
**INCLUDES** Wooden scraper

## 9 WOOD GÜIRO SHAKER

**MATERIAL** Siam Oak (*Hevea brasiliensis* Muell.-Arg.)  
**FEATURE** Additional shaker sound  
**INCLUDES** Wooden scraper





NINO557



NINO556



Medium  
NINO21

Large  
NINO22



Large  
NINO571

Medium  
NINO570



2 rows  
NINO560

3 rows  
NINO561



NINO9



NINO970

NINO971

**10 WOOD BALL STIRRING DRUM**

**MATERIAL** Siam Oak (*Hevea brasiliensis* Muell.-Arg.)  
**FEATURE** Ergonomically shaped handle

**11 WOOD STIRRING DRUM**

**MATERIAL** Siam Oak (*Hevea brasiliensis* Muell.-Arg.)  
**FEATURE** Ergonomically shaped handle  
**INCLUDES** Wooden beater

**12 WOOD BLOCKS**

**SIZES** NINO21: Medium  
NINO22: Large  
**MATERIAL** Siam Oak (*Hevea brasiliensis* Muell.-Arg.)  
**INCLUDES** Wooden beater

**13 WOOD TONE BLOCKS**

**SIZES** NINO570: Medium  
NINO571: Large  
**MATERIAL** Siam Oak (*Hevea brasiliensis* Muell.-Arg.)  
**FEATURE** Tonally matched resonating bodies  
**INCLUDES** Wooden beater

**14 WOOD A-GO-GO'S**

**SIZES** NINO560: 2 rows  
NINO561: 3 rows  
**MATERIAL** Siam Oak (*Hevea brasiliensis* Muell.-Arg.)  
**FEATURES** Different playing options  
Ergonomically shaped handle  
**INCLUDES** Wooden beater

**15 WOOD BEATER**

**MATERIAL** Siam Oak (*Hevea brasiliensis* Muell.-Arg.)  
**FEATURE** Can be used for most percussion instruments

**16 PERCUSSION MALLETS**

**SIZE** 10" long  
**MATERIALS** White Beech  
NINO970: Natural felt  
NINO971: Rubber  
**FEATURES** Great to use with woodblocks, hand drums, and other commonly found percussion instruments  
Extremely versatile and durable  
Different options for sound and touch  
Made of white beech  
Made in Germany  
NINO970: Big felt head, medium hard  
NINO971: Small rubber head, medium hard

# HAND PERCUSSION



## 1 JINGLE STICKS

**MATERIALS** ABS plastic frame  
Nickel Silver plated steel jingles

**FEATURES** Ergonomically shaped handle  
New sound ideas

**COLOURS** **BK:** Black  
**R:** Red  
**Y:** Yellow

## 2 SLEIGH BELL

**SIZE** 4 bells

**MATERIALS** Wooden handle  
Steel bells

**FEATURES** Ergonomic grip  
True sleigh bell sound

## 3 BELL STICK

**SIZE** 5" long

**MATERIALS** Wooden handle  
Steel bell

**FEATURES** Ergonomically shaped handle  
Bell mounted on stick

## 4 DOUBLE BELL STICK

**SIZE** 6" long

**MATERIALS** Wooden handle  
Steel bells

**FEATURES** Ergonomically shaped handle  
Steel bells mounted on each end

## 5 WRIST BELLS

**SIZE** 3 bells  
9" strap

**MATERIALS** Nylon strap  
Steel bells

**FEATURE** Hook and loop fastener

**COLOURS** **B:** Blue  
**GR:** Green  
**R:** Red

## 6 WOOD CLAVES

**SIZES** **NINO502:** Small  
**NINO574:** Regular

**MATERIAL** Siam Oak (*Hevea brasiliensis* Muell.-Arg.)

**FEATURE** Sold in pairs

## 7 MULTI-COLOURLED CLAVE PACK

**SIZE** Small

**MATERIAL** Siam Oak (*Hevea brasiliensis* Muell.-Arg.)

**FEATURES** 6 multi-coloured pairs of small wood claves  
Classic clave sounds  
Blends well with other instruments

## 8 CABASAS

**SIZES** **NINO701:** Small  
**NINO702:** Medium

**MATERIALS** Beech Wood  
Steel chain and cylinder

**FEATURE** Ergonomically shaped wooden handle



3 rows  
NINO580



Large  
NINO579L



Medium  
NINO579M



Small  
NINO579S



NINO901



NINO902



NINO602R



g# c' f' f' c'''  
NINO963GR

c' c' a' a' f' e' e''  
NINO964R

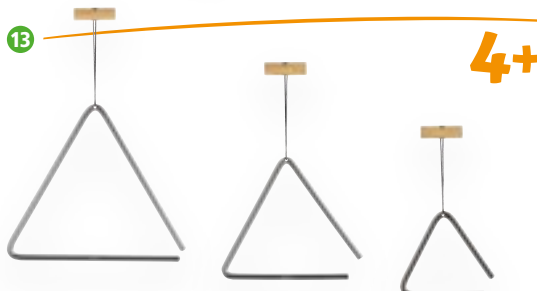

8"  
NINO552

6"  
NINO551

4"  
NINO550



NINO567



NINO505



NINO600

## 8 ENERGY CHIMES

**SIZES** NINO579S: Small  
NINO579M: Medium  
NINO579L: Large  
NINO580: 3 rows

**MATERIAL** Silver anodized aluminum alloy  
**INCLUDES** Wooden beater

## 9 GLOCKENSPIEL

**TONES** c, d, e, f, g, a, b, c  
**MATERIALS** Pine Wood body  
Removable colour-coded metal keys  
**INCLUDES** Two wooden mallets  
Songbook  
**FINISH** Matte

## 10 C MAJOR SCALE GLOCKENSPIEL

**TONES** c3, d3, e3, f-sharp3, g3. a3, b-flat3, b3, c4, d4, e4, f4

**MATERIALS** Wooden body  
Removable steel keys  
**INCLUDES** Two wooden mallets  
**FINISH** Matte

## 11 WAH-WAH TUBE

**MATERIAL** Anodized aluminum  
**INCLUDES** Wooden stick with rubber beater  
**COLOUR** R: Red

## 12 WOOD KALIMBAS

**SIZES** NINO963GR: Small – g# c' f' f' c'''  
NINO964R: Medium – c' c' a' a' f' e' e''  
**MATERIALS** Radiata Pine (*Pinups Radiata*)  
Chrome plated steel keys  
**FEATURES** Solid wood construction  
Light and pleasant sound  
**COLOURS** GR: Green  
R: Red

## 13 TRIANGLES

**SIZES** NINO550: 4"  
NINO551: 6"  
NINO552: 8"

**MATERIALS** Steel  
**INCLUDES** Wooden holder with braided nylon strap  
Metal beater with rubber padded grip

## 14 TRIANGLE BEATER

**MATERIAL** Steel

## 15 A-GO-GO BELL

**MATERIAL** Black powder coated steel  
**INCLUDES** Wooden beater

## 16 CHIMES

**SIZE** 12 bars  
**MATERIAL** Silver anodized aluminum alloy

# CYMBALS

1



Brass, 8"  
NINO-BR20



Bronze, 8"  
NINO-BO20



FX9, 8"  
NINO-NS20



FX9, 7"  
NINO-NS18

5+

2



FX9, 14"  
NINO-NS355



FX9, 12"  
NINO-NS305

5+

## 1 CYMBAL PAIRS

- SIZES** NINO-NS18: 7"  
NINO-BO20, NINO-BR20,  
NINO-NS20: 8"
- MATERIALS** NINO-BO20: B8 bronze alloy  
NINO-BR20: MS63 brass alloy  
NINO-NS18, NINO-NS20: FX9 alloy
- INCLUDES** Leather strap (BR4)

## 2 CYMBALS

- SIZES** NINO-NS305: 12"  
NINO-NS355: 14"
- MATERIAL** FX9 alloy
- INCLUDES** Leather strap (BR6)

## NINO® CYMBALS "MADE IN GERMANY"

The NINO® cymbals and cymbal pairs made out of valuable materials provide the best sound at an unbeatable price. The best possible sound and consistency is a result of our state-of-the-art cymbal manufacturing facility located in Germany.



# HOW TO PLAY

## CAJONS

1. Leaning over and hitting the cajon with your palm toward the middle of the front plate will produce a low end tone.
2. Slapping the cajon on the side or near the top will produce a high pitched tone.
3. Use your foot for a special playing technique.
4. Tilting the cajon makes it more comfortable on your back and wrists.



## DJEMBES

1. Place the djembe between your legs, crossing your ankles in front of you for support. Keeping your hands relaxed, strike the head of the drum near the edge for strong open and slap tones. Striking the drum in the middle will produce a powerful bass tone.
2. Alternating between your right and left hands, create your own patterns and rhythms.
3. Tune the djembe by using the provided tuning wrench to create a higher or lower sound.

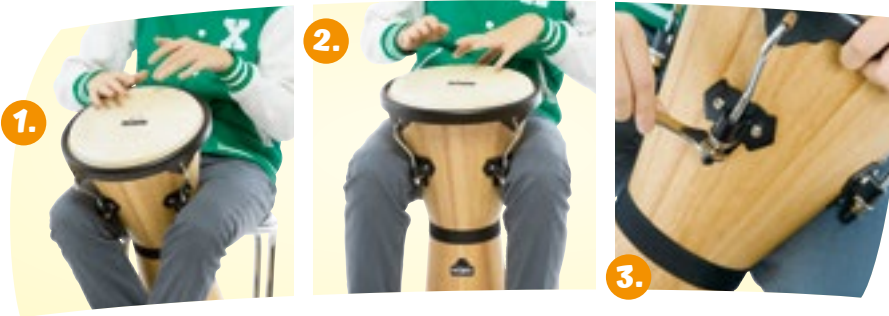

## BONGOS

1. Traditionally, you play the bongo between your legs with the smaller drum on your left. A slap tone is produced by cupping your fingers slightly as you strike the head of the bongo.
2. To create an open tone, strike near the edge of the bongo head with the length of your fingers in a loose slapping motion, letting your fingers bounce as you make contact with the drum.

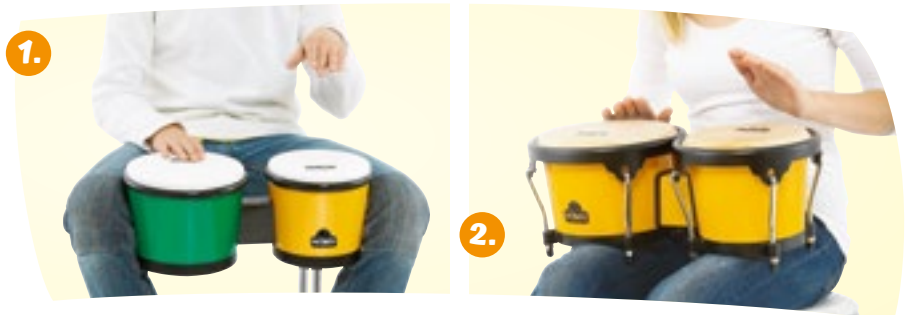

## CONGAS

1. Keeping your hands relaxed, strike the head of the conga near the edge for strong open and slap tones. Striking the drum in the middle will produce a powerful bass tone.
2. Use the two congas together to create fun rhythmic and melodic patterns.
3. Tune the conga by using the provided tuning wrench to create a higher or lower sound.

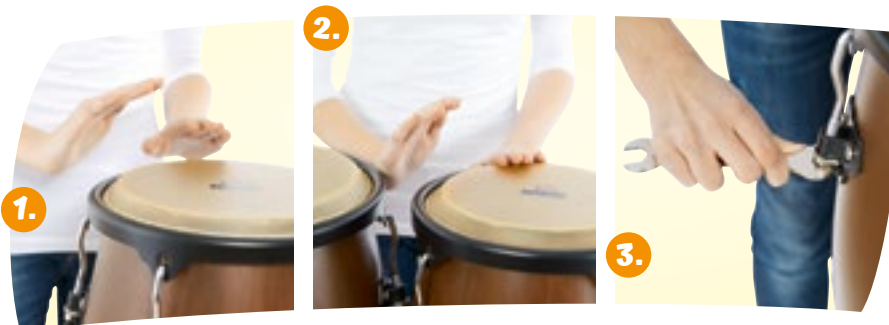

## SEA DRUMS

1. Hold the sea drum horizontally and turn the drum slowly to create the sound of waves flowing in the sea.
2. Striking the sea drum in a horizontal position will create a crashing waves sound.
3. Holding the drum vertical and striking the heads will create a more traditional drum sound with some added rattle for a variety of interesting effects.





MEINL Sonic Energy is a collection of instruments that supports our connection to experience the body, mind and energy, as One. Many practitioners and guides within the health and wellness industry use these instruments therapeutically for stress management, anxiety relief, insomnia, depression, addictive recovery, pain management, ect. They are unique expressions of the vibrations we encounter on a daily basis and when listened to closely, seem to have a language all their own. They invite us to appreciate the definition of all things we find harmonious in our life and through this support, our journey begins toward new peace and restoration. Our collection of beautifully crafted creations makes self-discovery through sound a simple, profound practice.

Singing Bowls	02
Singing Bowl Accessories	06
Gongs	08
Flower of Life Collection	08
Gong Stands	11
Gong Mallets & Beaters	12
Gong Accessories	13
Tuning Forks	14
Tuning Fork Accessories	15
Energy Chimes	16
Sound Effects	17
Harmonic Art Handpans	18
Handpan Accessories	20
Steel Tongue Drums	21
Frame Drums	22

# MEINL SONIC ENERGY



# SINGING BOWLS

## 1 NEW



SB-O-600



SB-O-700



SB-O-900

## 2 NEW



Set, 3 pcs.  
SB-O-2200

## 3



SB-U-400



SB-U-500



SB-U-600



SB-U-700



SB-U-750

SHAPE



## 4



Set, 2 pcs.  
SB-U-900



Set, 3 pcs.  
SB-U-1500



Set, 4 pcs.  
SB-U-1750



Set, 3 pcs.  
SB-U-1950



Set, 5 pcs.  
SB-U-2950

### 1 ORIGIN SERIES SINGING BOWLS

**DIMENSIONS** **SB-O-600:** ~5.1" diameter; ~600 g  
**SB-O-700:** ~5.7" diameter; ~700 g  
**SB-O-900:** ~6.7" diameter; ~900 g

**MATERIAL** Special bronze alloy

**FEATURES** Ideal for yoga and meditation  
Handcrafted masterpiece made in India  
Engraved logo on the bottom

**INCLUDES** Corresponding cover and felt ring

### 2 ORIGIN SERIES SINGING BOWL SET

**CONTAINS** SB-O-600, SB-O-700, SB-O-900

**INCLUDES** Corresponding covers and felt rings;  
Mallet SB-M-ST-L

### 3 UNIVERSAL SERIES SINGING BOWLS

**DIMENSIONS** **SB-U-400:** ~4.5" diameter; ~400 g  
**SB-U-500:** ~4.9" diameter; ~500 g  
**SB-U-600:** ~5.5" diameter; ~600 g  
**SB-U-700:** ~5.9" diameter; ~700 g  
**SB-U-750:** ~6.5" diameter; ~750 g

**MATERIAL** Special bronze alloy

**FEATURES** Ideal for yoga and meditation  
Handcrafted masterpiece made in India  
Engraved logo

**INCLUDES** Corresponding cover and felt ring

### 4 UNIVERSAL SERIES SINGING BOWL SETS

**CONTAINS** **SB-U-900:** SB-U-400, SB-U-500  
**SB-U-1500:** SB-U-400, SB-U-500,  
SB-U-600

**SB-U-1750:** SB-U-400, SB-U-500,  
SB-U-600, SB-C-250

**SB-U-1950:** SB-U-500, SB-U-700,  
SB-U-750

**SB-U-2950:** SB-U-400, SB-U-500,  
SB-U-600, SB-U-700, SB-U-750

**INCLUDES** Corresponding covers and felt rings;  
Resonant Mallet SB-RM-LE  
**SB-U-2950:** Mallet SB-M-LT-S



5

SHAPE



SB-E-700



SB-E-1000



SB-E-1400



SB-E-1800



SB-E-2200



SB-E-2500

6



Set, 3 pcs.  
SB-E-3100

Therapy  
Basis Set



Set, 3 pcs.  
SB-E-4600



Set, 3 pcs.  
SB-E-5400



### 5 ENERGY THERAPY SERIES SINGING BOWLS

**DIMENSIONS** SB-E-700: ~6.4" diameter; ~700 g  
SB-E-1000: ~7.8" diameter; ~1000 g  
SB-E-1400: ~9.0" diameter; ~1400 g  
SB-E-1800: ~10.2" diameter; ~1800 g  
SB-E-2200: ~11.4" diameter; ~2200 g  
SB-E-2500: ~12.2" diameter; ~2500 g

**MATERIAL** Special bronze alloy  
**FEATURES** Ideal for upper body sound massage  
Reinforcement rim that will produce a high tone at first followed afterwards by a deep tone  
Handcrafted masterpiece made in India  
Engraved logo

**INCLUDES** Corresponding cover and felt ring

### 6 ENERGY THERAPY SERIES SINGING BOWL SETS

**CONTAINS** SB-E-3100: SB-E-700, SB-E-1000, SB-E-1400  
SB-E-4600: SB-E-1000, SB-E-1400, SB-E-2200  
SB-E-5400: SB-E-1400, SB-E-1800, SB-E-2200

**INCLUDES** Corresponding covers and felt rings  
SB-E-3100: Resonant Mallet SB-RM-LE; Mallet SB-M-ST-L  
SB-E-4600: Professional Mallets SB-PM-MF-S, SB-PM-MF-L  
SB-E-5400: Resonant Mallet SB-RM-LE; Mallets SB-M-LT-L, SB-M-ST-L

# SINGING BOWLS

1



SHAPE



SB-C-250

SB-C-650

SB-C-800

SB-C-1000

SB-C-1500

2



SB-C-2000

SB-C-2500



Set, 4 pcs.  
SB-C-2700



Set, 4 pcs.  
SB-C-4750



Set, 3 pcs.  
SB-C-3800

3



Set, 7 pcs.  
SB-SET-CHA

## 1 COSMOS THERAPY SERIES SINGING BOWLS

**DIMENSIONS** SB-C-250: ~3.7" diameter; ~250 g  
SB-C-650: ~5.8" diameter; ~650 g  
SB-C-800: ~6.6" diameter; ~800 g  
SB-C-1000: ~7.6" diameter; ~1000 g  
SB-C-1500: ~9.0" diameter; ~1500 g  
SB-C-2000: ~10.3" diameter; ~2000 g  
SB-C-2500: ~11.5" diameter; ~2500 g

**MATERIAL** Special bronze alloy

**FEATURES** Ideal for yoga and meditation  
Generates a sustained deep tone that will fill a room with ambient sounds  
Handcrafted masterpiece made in India  
Engraved logo

**INCLUDES** Corresponding cover and felt ring

## 2 COSMOS THERAPY SERIES SINGING BOWL SETS

**CONTAINS** SB-C-2700: SB-C-250, SB-C-650, SB-C-800, SB-C-1000  
SB-C-3800: SB-C-800, SB-C-1000, SB-C-2000

**INCLUDES** Corresponding covers and felt rings;  
SB-C-2700: Resonant Mallet SB-RM-LE; Mallet SB-M-LT-S  
SB-C-3800: Professional Mallets SB-PM-MF-S, SB-PM-MF-L  
SB-C-4750: Resonant Mallet SB-RM-LE; Mallets SB-M-LT-L, SB-M-ST-L

## 3 CHAKRA SINGING BOWL SET

**CONTAINS** SB-C-250, SB-E-700, SB-E-1000, SB-E-1400, SB-C-1500, SB-E-1800, SB-E-2200,

**INCLUDES** Corresponding covers and felt rings; Mallets SB-M-LT-L, SB-M-ST-L, SB-M-ST-S, SB-M-LT-S; Professional Mallet SB-PDM-F-XL



Set, 3 pcs.  
SB-SE-2400



Flower of Life  
SB-S-FOL-1000

Venus Flower  
SB-S-VF-1000



SB-G-5000



SB-G-10000



SB-G-12000



SB-G-13000



SB-G-14000

#### 4 SPECIAL ENGRAVED SERIES SINGING BOWLS

**DIMENSIONS** SB-SE-600: ~5.35" diameter; ~600 g  
SB-SE-800: ~6.7" diameter; ~800 g  
SB-SE-1000: ~8.0" diameter; ~1000 g

**MATERIAL** Special bronze alloy  
**FEATURES** Perfect combination of a pleasing sound and look  
Handcrafted masterpiece made in India  
Brilliant finish  
Hand-engraved ornamental design  
Engraved logo  
**INCLUDES** Corresponding cover and felt ring

#### 5 SPECIAL ENGRAVED SERIES SINGING BOWL SET

**CONTAINS** SB-SE-600, SB-SE-800, SB-SE-1000  
**INCLUDES** Corresponding covers and felt rings;  
Resonant Mallet SB-RM-LE;  
Mallet SB-M-LT-S

#### 6 SYNTHESIS SERIES SINGING BOWLS

**DIMENSIONS** ~7.6" diameter; ~1000 g  
**MATERIAL** Special bronze alloy  
**FEATURES** Ideal for meditation, sound therapy, concerts and yoga  
Generates a sustained deep tone that will fill a room with ambient sounds  
Handcrafted masterpiece made in India  
Engraved logo  
**SYMBOLS** FOL: Flower of Life  
VF: Venus Flower  
**INCLUDES** Corresponding cover and felt ring

#### 7 GIANT SERIES

**DIMENSIONS** SB-G-5000: ~15.75" diameter; ~5000 g  
SB-G-10000: ~21.26" diameter; ~10000 g  
SB-G-12000: ~21.26" diameter; ~12000 g  
SB-G-13000: ~22.05" diameter; ~13000 g  
SB-G-14000: ~24.0" diameter; ~14000 g  
**MATERIAL** Special bronze alloy  
**FEATURES** Ideal for sound therapy and can also be used for a full body experience by standing in these bowls  
Handcrafted masterpiece made in India  
Engraved logo  
**INCLUDES** Corresponding buckwheat cushion  
SB-G-14000: Professional Mallet SB-PM-XXL

# SINGING BOWLS & ACCESSORIES

1



SB-OR-300-BK



SB-OR-300-R



SB-OR-400-BK



SB-OR-400-R

2



SB-OM-300

3



Small  
SB-ST-S

Large  
SB-ST-L

## 1 ORNAMENTAL SERIES SINGING BOWLS

**DIMENSIONS** **SB-OR-300:** ~3.74" diameter; ~300 g  
**SB-OR-400:** ~4.13" diameter; ~400 g

**MATERIAL** Special cast alloy  
**FEATURES** Brilliant finish  
Hand-painted ornamental design  
Great gift idea

**SB-OR-300:** Consistently warm, high pitched sound  
**SB-OR-400:** Consistently warm, low pitched sound

**INCLUDES** Corresponding mallet and coaster  
**BK:** Black gift box  
**R:** Red gift box

## 2 OM SERIES SINGING BOWL

**DIMENSIONS** ~4.33" diameter; ~300 g

**MATERIAL** Special cast alloy  
**FEATURES** Consistently warm, low pitched sound  
Brilliant finish  
Hand-painted OM design  
Great gift idea

**INCLUDES** Corresponding mallet and ring  
Gift box

## 3 SINGING BOWL STANDS

**SIZES** **S:** Small  
**L:** Large

**MATERIAL** Birch  
**FEATURES** Padded layer for stability  
Heat-branded logo

## 4 MALLETS

**DIMENSIONS** **SB-M-ST-S:** Small tip; Small (8.27")  
**SB-M-LT-S:** Large tip; Small (8.27")  
**SB-M-ST-L:** Small tip; Large (12.44")  
**SB-M-LT-L:** Large tip; Large (12.44")

**MATERIALS** Natural felt tip  
Wooden handle  
**FEATURE** Heat-branded logo

## 5 RESONANT MALLETS

**DIMENSIONS** **SB-RM:** Plain; 7.91"  
**SB-RM-LE:** Leather; 7.91"  
**SB-RM-LE-L:** Leather; 10.24"  
**SB-RM-LE-XL:** Leather; 10.63"

**MATERIAL** Wood  
**FEATURE** Heat-branded logo

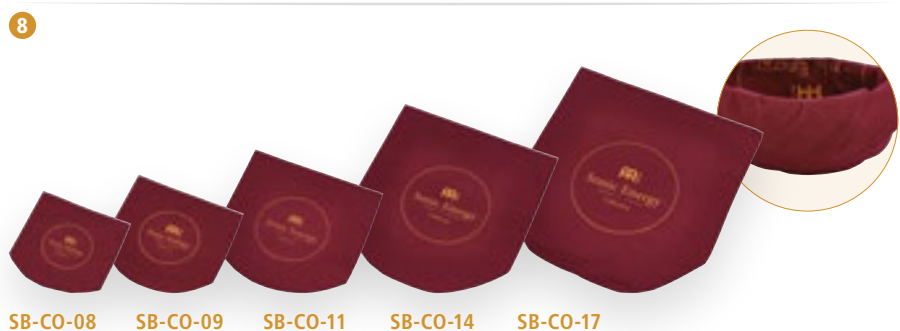
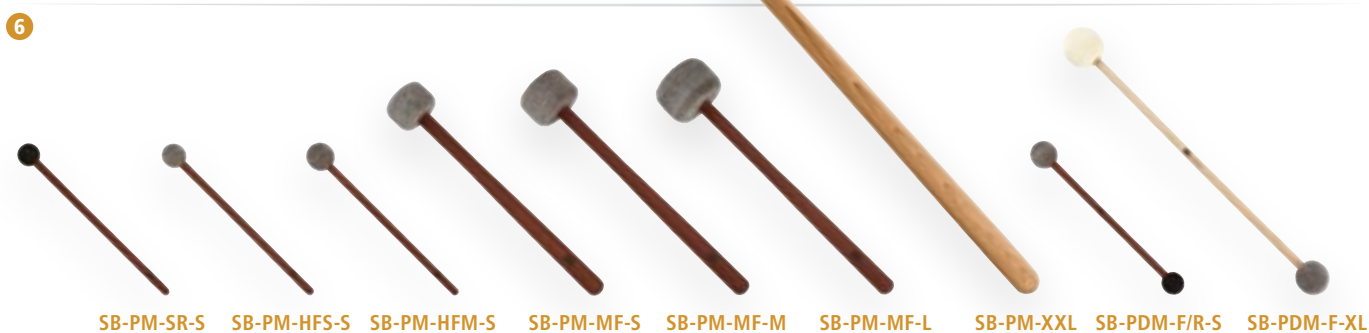

## 6 PROFESSIONAL MALLET

**DIMENSIONS** **SB-PM-SR-S:** Soft rubber tip; Small (8.86")  
**SB-PM-HFS-S:** Hard felt, small tip; Small (8.86")  
**SB-PM-HFM-S:** Hard felt, medium tip; Small (8.86")  
**SB-PM-MF-S:** Medium felt tip; Small (12.01")  
**SB-PM-MF-M:** Medium felt tip; Medium (12.99")  
**SB-PM-MF-L:** Medium felt tip; Large (13.78")  
**SB-PM-XXL:** Felt tip, XX-Large (27.56")  
**SB-PDM-F/R-S:** Double Mallet; Felt & rubber tip; Small (9.25")  
**SB-PDM-F-XL:** Double Mallet; Felt tips; X-Large (15.94")

**MATERIALS** Sapele wood handle except:  
**SB-PM-XXL:** Beech wood handle

**FEATURE** **SB-PDM-F-XL:** Hard maple handle  
 Printed logo

## 7 FELT RINGS

**SIZES** **SB-FR-08:** 3.15" diameter  
**SB-FR-10:** 3.94" diameter  
**SB-FR-13:** 5.12" diameter  
**SB-FR-16:** 6.3" diameter

**MATERIAL** Natural felt  
**FEATURE** Nonslip

## 8 COVERS

**SIZES** **SB-CO-08:** 8" x 8"  
**SB-CO-09:** 9.5" x 9.5"  
**SB-CO-11:** 11.5" x 11.5"  
**SB-CO-14:** 14" x 15.5"  
**SB-CO-17:** 17" x 19"

**MATERIAL** Synthetic  
**FEATURES** Prevents from dust and fingerprints  
 Printed logo

## 9 BUCKWHEAT CUSHIONS

**SIZES** **SB-BC-10:** 3.94" diameter  
**SB-BC-16:** 6.3" diameter  
**SB-BC-21:** 8.27" diameter  
**SB-BC-26:** 10.24" diameter

**FEATURES** Filled with buckwheat  
 Transferring vibrations while playing  
 Embroidered logo

## 10 COTTON BAGS

**SIZES** **SB-CB-20:** 7.87" x 7.87"  
**SB-CB-25:** 9.84" x 9.84"  
**SB-CB-30:** 11.81" x 11.81"  
**SB-CB-38:** 14.96" x 14.96"  
**SB-CB-50:** 19.69" x 19.69"

**MATERIALS** Natural cotton linen fabric  
 Synthetic fleece inlay

**FEATURES** Safe transport method  
 Prevents from scratches  
 Embroidered logo

# GONGS

1



DESIGNED  
IN COOPERATION  
WITH DON CONREUX

BACK



32" / 81 cm  
G32-DC-B

2

五 = WU 行 = XING



24" / 61 cm  
G24-WX

28" / 71 cm  
G28-WX

32" / 81 cm  
G32-WX

36" / 91 cm  
G36-WX

40" / 101 cm  
G40-WX

3



24" / 61 cm  
SY-TT24

28" / 71 cm  
SY-TT28

32" / 81 cm  
SY-TT32

36" / 91 cm  
SY-TT36

4



Tuning Fork  
TF-FOL

5



24" / 61 cm  
G24-FOL

36" / 91 cm  
G36-FOL

6



Energy Chime  
EC-FOL

## FLOWER OF LIFE COLLECTION

DESIGNED IN COOPERATION WITH JENS ZYGAR

### 1 DON CONREUX EIGHT CORNERS OF HEAVEN MIRROR GONG

**SIZE** 32"  
**MATERIAL** Nickelsilver  
**TUNING** D2 - D2#  
**FEATURES** Handcrafted masterpiece made in Germany  
Exact fine tuning through hand-hammering  
Printed ancient mysterious symbols on front and tuning info on the back  
The eight runic glyphs represent the cycle of life  
Mirror surface allows player to see himself, listeners or other gong players  
**INCLUDES** Cover and gloves

### 2 WU XING GONGS

**SIZES** G24-WX: 24"; G28-WX: 28";  
G32-WX: 32"; G36-WX: 36";  
G40-WX: 40"  
**MATERIAL** Nickelsilver

**TUNING** G24-WX: G2 - G2#  
G28-WX: E2 - F2  
G32-WX: C2# - D2  
G36-WX: A1# - B1 (H1)  
G40-WX: G1 - G1#

**FEATURES** Handcrafted masterpiece made in Germany  
Gentle frequency range  
Printed logo on front and tuning info on the back  
**INCLUDES** Gong handle, cover and gloves

### 3 SYMPHONIC TAM TAMS

**SIZES** SY-TT24: 24"; SY-TT28: 28";  
SY-TT32: 32"; SY-TT36: 36"  
**MATERIAL** Nickelsilver  
**TUNING** SY-TT24: G2 - G2#  
SY-TT28: E2 - F2  
SY-TT32: C2# - D2  
SY-TT36: A1# - B1 (H1)

**FEATURES** Handcrafted masterpiece made in Germany  
Printed logo on front and tuning info on the back  
**INCLUDES** Cover and gloves

### 4 FLOWER OF LIFE TUNING FORK

**SIZE** 8.3"  
**MATERIAL** Premium nickel plated steel  
**TUNING** 128 Hz  
**FEATURES** Handcrafted masterpiece made in Germany  
Ergonomic shaped cork handle  
Engraved logo and tuning info

### 5 FLOWER OF LIFE GONGS

**SIZES** G24-FOL: 24"; G36-FOL: 36"  
**MATERIAL** Nickelsilver  
**TUNING** G24-FOL: 128 Hz / C3  
(A4/a' 440 Hz » 430.54 Hz)  
G36-FOL: 64 Hz / C2  
(A4/a' 440 Hz » 430.54 Hz)

7

抄



22" / 56 cm  
CH-TT22

26" / 66 cm  
CH-TT26

30" / 76 cm  
CH-TT30

34" / 86 cm  
CH-TT34

38" / 96 cm  
CH-TT38

40" / 101 cm  
CH-TT40

8



20" / 50 cm  
WG-TT20

22" / 55 cm  
WG-TT22

24" / 60 cm  
WG-TT24

26" / 65 cm  
WG-TT26

28" / 70 cm  
WG-TT28

30" / 75 cm  
WG-TT30

32" / 80 cm  
WG-TT32

36" / 90 cm  
WG-TT36

40" / 101 cm  
WG-TT40

9



12" / 30 cm  
OG-12

10



12" / 30 cm  
WG-12

14.5" / 37 cm  
WG-145

11



12.5" / 31.5 cm  
TG-125

**FEATURES** Handcrafted masterpiece made in Germany  
Exact fine tuning through hand-hammering  
Printed logo on front and tuning info on the back

**INCLUDES** Cover and gloves

**6 FLOWER OF LIFE ENERGY CHIME**

**MATERIAL** Silver anodized aluminum alloy

**TUNING** 2048 Hz / C7

**FEATURES** Handcrafted masterpiece made in Thailand  
Exact fine tuning  
Heat-branded logo and tuning info

**INCLUDES** Wooden beater

**7 CHAU TAM TAMS**

**SIZES** CH-TT22: 22"; CH-TT26: 26";  
CH-TT30: 30"; CH-TT34: 34";  
CH-TT38: 38"; CH-TT40: 40"

**MATERIAL** Special bronze alloy

**FEATURES** Handcrafted masterpiece made in China

**INCLUDES** Printed logo and size info on the front  
Beater and cover

**8 WIND GONGS**

**SIZES** WG-TT20: 20"; WG-TT22: 22";  
WG-TT24: 24"; WG-TT26: 26";  
WG-TT28: 28"; WG-TT30: 30";  
WG-TT32: 32"; WG-TT36: 36";  
WG-TT40: 40"

**MATERIAL** Special bronze alloy

**FEATURES** Handcrafted masterpiece made in China  
Mainly low pitched sound  
Sizzling overtones  
Printed logo and size info on the front

**INCLUDES** Beater and cover

**9 OPERA GONG**

**SIZE** 12"

**MATERIAL** Special bronze alloy

**FEATURES** Handcrafted masterpiece made in China

**INCLUDES** Descending pitch  
Audible glissando effect with very short sustain  
Beater

**10 WHITE GONGS**

**SIZES** WG-12: 12"; WG-145: 14.5"

**MATERIAL** Special bronze alloy

**FEATURES** Handcrafted masterpiece made in China  
Powerful and splashy clear sound  
Flat profile with bended rim

**INCLUDES** Beater

**11 TIGER GONG**

**SIZE** 12.5"

**MATERIAL** Special bronze alloy

**FEATURES** Handcrafted masterpiece made in China  
Splashy sound  
Pronounced bent-out shape

**INCLUDES** Beater

# PLANETARY TUNED GONGS



Sidereal Moon,  
24" / 61 cm  
**G24-M-SI**

Synodic Moon,  
24" / 61 cm  
**G24-M-SY**

Neptune,  
24" / 61 cm  
**G24-N**

Uranus,  
24" / 61 cm  
**G24-U**

Venus,  
24" / 61 cm  
**G24-V**



Chiron,  
28" / 71 cm  
**G28-CH**

Platonic Year,  
28" / 71 cm  
**G28-E-PL**

Sidereal Day,  
28" / 71 cm  
**G28-E-SI**

Jupiter,  
28" / 71 cm  
**G28-J**

Sedna,  
28" / 71 cm  
**G28-SE**



Mars,  
32" / 81 cm  
**G32-MA**

Mercury,  
32" / 81 cm  
**G32-ME**

Saturn,  
32" / 81 cm  
**G32-SA**

Earth,  
36" / 91 cm  
**G36-E**

Sun,  
36" / 91 cm  
**G36-S**

## PLANETARY TUNED GONGS

**SIZES**  
**G24:** 24"  
**G28:** 28"  
**G32:** 32"  
**G36:** 36"

**MATERIAL**  
 Nickelsilver

**TUNING**  
**G24-M-SI:** Sidereal Moon, 227.43 Hz / A2# (A4/a' 440 Hz » 429.33 Hz)  
**G24-M-SY:** Synodic Moon, 210.42 Hz / G2# (A4/a' 440 Hz » 445.86 Hz)  
**G24-N:** Neptune, 211.44 Hz / G2# (A4/a' 440 Hz » 448.03 Hz)  
**G24-U:** Uranus, 207.36 Hz / G2# (A4/a' 440 Hz » 439.38 Hz)  
**G24-V:** Venus, 221.23 Hz / A2 (A4/a' 440 Hz » 442.46 Hz)  
**G28-CH:** Chiron, 172.86 Hz / F2 (A4/a' 440 Hz » 435.58 Hz)

**G28-E-PL:** Platonic Year, 172.06 Hz / F2 (A4/a' 440 Hz » 433.56 Hz)  
**G28-E-SI:** Sidereal Day, 194.71 Hz / G2 (A4/a' 440 Hz » 437.11 Hz)  
**G28-J:** Jupiter, 183.58 Hz / F2# (A4/a' 440 Hz » 436.63 Hz)  
**G28-SE:** Sedna, 181.60 Hz / F2# (A4/a' 440 Hz » 431.92 Hz)  
**G32-MA:** Mars, 144.72 Hz / D2 (A4/a' 440 Hz » 433.67 Hz)  
**G32-ME:** Mercury, 141.27 Hz / C2# (A4/a' 440 Hz » 448.50 Hz)  
**G32-SA:** Saturn, 147.85 Hz / D2 (A4/a' 440 Hz » 443.05 Hz)  
**G36-E:** Earth, 136.10 Hz / C2# (A4/a' 440 Hz » 432.09 Hz)  
**G36-S:** Sun, 126.22 Hz / B1 (H1) (A4/a' 440 Hz » 449.80 Hz)

**FEATURES** Handcrafted masterpiece made in Germany  
 Exact fine tuning through hand-hammering  
 Printed alchemical symbols for each planet on front and tuning info on the back

**INCLUDES** Cover and gloves



# GONG STANDS



TMGS



TMGS-2



TMGS-2-G



TMGS-DS



Set  
TMGS-W



TMGS-3



TMGS-3-G



Medium  
TMWGS-M

Large  
TMWGS-L

X-Large  
TMWGS-XL



Small  
TMTGS-S



Medium  
TMTGS-M



Large  
TMTGS-L



X-Large  
TMTGS-XL



## 1 GONG STAND

**SIZE** Up to 32" gong size  
**MATERIAL** Black powder coated steel  
**FEATURE** Height adjustable with locking system  
**INCLUDES** Allen wrench

## 2 PRO GONG STAND

**SIZE** Up to 40" gong size  
**MATERIAL** Black powder coated steel  
**FEATURES** Especially for bigger sized gongs  
Height adjustable with locking system  
**INCLUDES** Allen wrench

## 3 GONG HOLDER

**SIZE** Upper gong size up to 32"  
Lower gong size up to 40"  
**MATERIAL** Black powder coated steel  
**FEATURE** For Pro Gong Stand only  
**INCLUDES** Allen wrench

## 4 GONG DAMPENING SYSTEM

**MATERIALS** Black powder coated steel; Foam  
**FEATURES** To consistently mute a gong  
Height adjustable to mute all gong sizes

## 5 WHEELS FOR GONG STANDS

**FEATURES** Set of four  
For ease of mobility

## 6 FRAMED GONG STAND

**SIZE** Up to 40" gong size  
**MATERIAL** Black powder coated steel  
**FEATURES** Especially for bigger sized gongs  
Height adjustable with locking system  
**INCLUDES** Allen wrench

## 7 FRAMED GONG HOLDER

**SIZE** Upper gong size up to 38"  
Lower gong size up to 40"  
**MATERIAL** Black powder coated steel

**FEATURES** For Framed Gong Stand only  
**INCLUDES** Allen wrench

## 8 WOOD GONG STANDS

**SIZES** **M:** Medium; Up to 34" gong size  
**L:** Large; Up to 40" gong size  
**XL:** X-Large; Up to 50" gong size  
**MATERIAL** Beech wood  
**FEATURE** Easy plug-in system

## 9 TABLE GONG STANDS

**SIZES** **S:** Small; Up to 13" gong size  
**M:** Medium; Up to 15" gong size  
**L:** Large; Up to 22" gong size  
**XL:** X-Large; Up to 26" gong size  
**MATERIAL** Black powder coated steel  
**FEATURES** Gong can be played in comfortable position on the floor or table  
**INCLUDES** Hex key

# GONG MALLETS & BEATERS

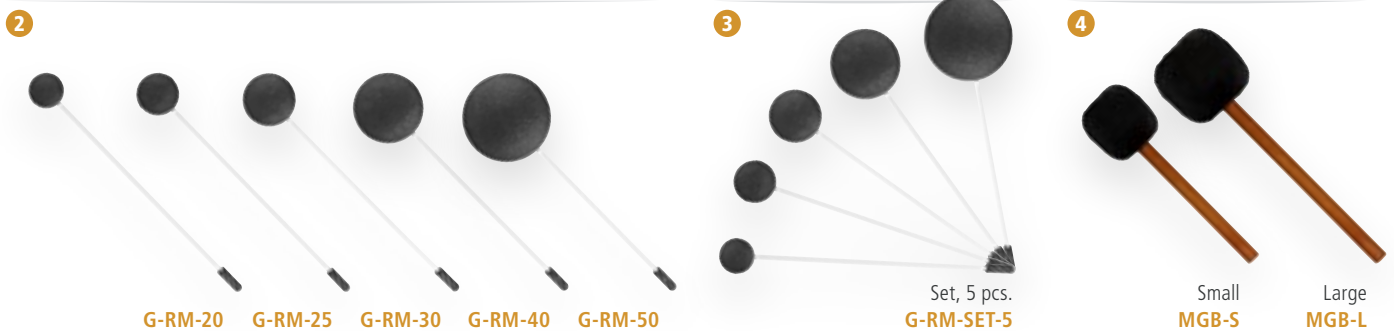

## 1 GONG MALLETS

**DIMENSIONS** **MGM-S:** Small (11.81" x 2.76" x 2.76"); 138 g; For gongs from 20" to 80"  
**MGM-M:** Medium (13.58" x 3.15" x 3.15"); 222 g; For gongs from 22" to 80"  
**MGM-L:** Large (15.55" x 3.94" x 3.94"); 374 g; For gongs from 24" to 80"

**MATERIALS** Beech wood handle; Fleece

**FEATURE** May be used also as a pair

**COLOURS** **C:** Chai  
**L:** Lavender  
**PG:** Pure Green  
**R:** Rose  
**SP:** Sea Petrol  
**ST:** Sweet Tangerine

## 2 GONG RESONANT MALLET SET

**SIZES** **G-RM-20:** 0.8"  
**G-RM-25:** 1.0"  
**G-RM-30:** 1.2"  
**G-RM-40:** 1.6"  
**G-RM-50:** 2.0"

**MATERIAL** Specially treated rubber ball

**FEATURES** Produces a gentle effect of the high and deepest low tones  
 Explore therapeutic and atmospheric sounds with these mallets

## 3 GONG RESONANT MALLET SET

**CONTAINS** **G-RM-SET-5:** G-RM-20, G-RM-25, G-RM-30, G-RM-40, G-RM-50

## 4 GONG BEATERS

**DIMENSIONS** **MGB-S:** Small; +/- 220 g; For gongs up to 28"  
**MGB-L:** Large; +/- 350 g; For gongs up to 40"

**MATERIAL** Sapele wood handle

**FEATURES** To create a wide range of dynamics  
 Heat-branded logo

## 5 TAM TAM BEATERS

**DIMENSIONS** **MTTB-24:** +/- 250 g; For 24" tam tams  
**MTTB-28:** +/- 500 g; For 28" tam tams  
**MTTB-32:** +/- 600 g; For 32" tam tams  
**MTTB-36:** +/- 700 g; For 36" tam tams  
**MTTB-40:** +/- 800 g; For 40" tam tams

**MATERIAL** Beech wood handle

## 6 MALLET BAG

**MATERIAL** Heavy-duty padded nylon

**FEATURE** Carrying grip

# GONG ACCESSORIES

1

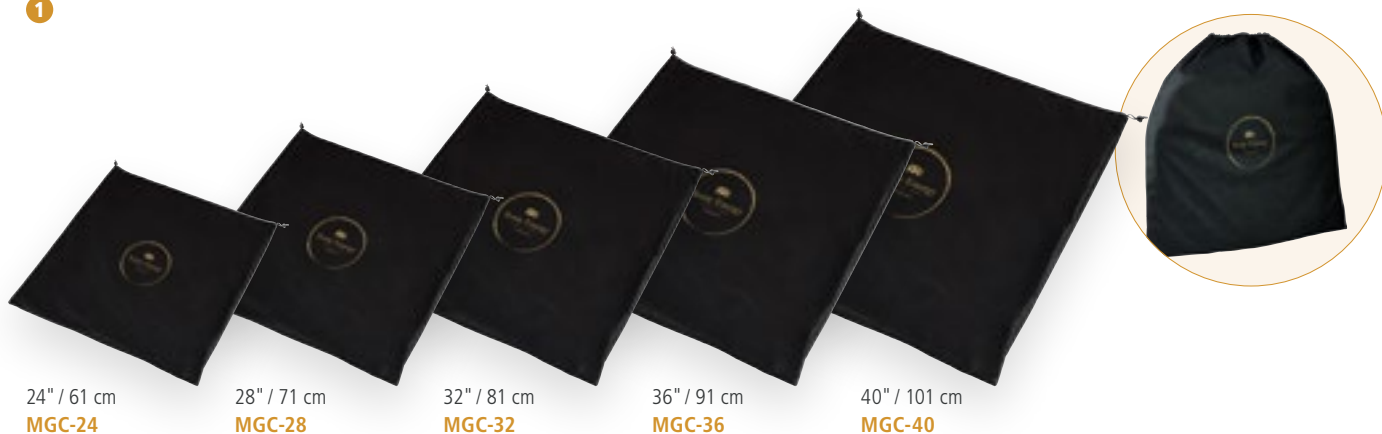

24" / 61 cm  
**MGC-24**

28" / 71 cm  
**MGC-28**

32" / 81 cm  
**MGC-32**

36" / 91 cm  
**MGC-36**

40" / 101 cm  
**MGC-40**

2



24" / 61 cm  
**MGB-24**

28" / 71 cm  
**MGB-28**

32" / 81 cm  
**MGB-32**

36" / 91 cm  
**MGB-36**

**NEW**

38" / 96 cm  
**MGB-38**

40" / 101 cm  
**MGB-40**

3

**NEW**



**GC-2428**

**GC-32**

**GC-3640**

4



**G-HANDLE**

5



**MGP**

6



**MCCK-MCCL**

## 1 GONG COVERS

**SIZES** **MGC-24:** For 24" gongs  
**MGC-28:** For 28" gongs  
**MGC-32:** For 32" gongs  
**MGC-36:** For 36" gongs  
**MGC-40:** For 40" gongs

**MATERIALS** Inner material velvet  
Outer material polyester

**FEATURE** Protects against dust and fingerprints

## 2 GONG BAGS

**SIZES** **MGB-24:** For 24" gongs  
**MGB-28:** For 28" gongs  
**MGB-32:** For 32" gongs  
**MGB-36:** For 36" gongs  
**MGB-38:** For 38" gongs  
**MGB-40:** For 40" gongs

**MATERIALS** Inner material velvet  
Outer material durable nylon

**FEATURE** Protects during transportation

## 3 GONG CORDS

**SIZES** **GC-2428:** For gongs from 24" to 28"  
**GC-32:** For 32" gongs  
**GC-3640:** For gongs from 36" to 40"

## 4 GONG HANDLE

**MATERIAL** Beech wood  
**FEATURE** For comfortable holding

## 5 GONG POLISH

**SIZE** 250 ml  
**FEATURE** For polishing the surface of a gong

## 6 CARE KIT

**FEATURES** For cleaning and protecting the surface of a gong  
Not affecting the sound  
Easy-to-use spray

**INCLUDES** Cymbal handling gloves

# PLANETARY TUNED TUNING FORKS



Set, 16 pcs.

TF-SET-16 / TF-SET-16C

## 1 PLANETARY TUNED TUNING FORKS

SIZES	
TF-CH:	7.3"
TF-E:	8.0"
TF-E-PL:	7.4"
TF-E-SI:	7.1"
TF-E-SY:	7.1"
TF-J:	7.2"
TF-M-SI:	6.7"
TF-M-SY:	6.9"
TF-MA:	7.8"
TF-ME:	7.9"
TF-N:	6.9"
TF-PL:	8.0"
TF-S:	8.3"
TF-SA:	7.8"
TF-SE:	7.2"
TF-SF:	6.5"
TF-U:	6.9"
TF-V:	6.8"

MATERIAL	Premium nickel plated steel
TUNING	
TF-CH:	Chiron, 172.86 Hz / F3
TF-E:	Earth, 136.10 Hz / C3#
TF-E-PL:	Platonic Year, 172.06 Hz / F3
TF-E-SI:	Sidereal Day, 194.71 Hz / G3
TF-E-SY:	Synodic Day, 194.18 Hz / G3
TF-J:	Jupiter, 183.58 Hz / F3#
TF-M-SI:	Sidereal Moon, 227.43 Hz / A3#
TF-M-SY:	Synodic Moon, 210.42 Hz / G3#
TF-MA:	Mars, 144.72 Hz / D3
TF-ME:	Mercury, 141.27 Hz / C3#
TF-N:	Neptune, 211.44 Hz / G3#
TF-PL:	Pluto, 140.64 Hz / C3#
TF-S:	Sun, 126.22 Hz / B2 (H2)
TF-SA:	Saturn, 147.85 Hz / D3
TF-SE:	Sedna, 181.60 Hz / F3#
TF-SF:	Schumann, 250.56 Hz / H3
TF-U:	Uranus, 207.36 Hz / G3#
TF-V:	Venus, 221.23 Hz / A3

FEATURES	
	Handcrafted masterpiece made in Germany
	Ergonomic shaped cork handle
	Engraved logo and tuning info

## 2 TUNING FORK SET-UP

CONTAINS	
	TF-CH, TF-E, TF-E-PL, TF-E-SI, TF-E-SY, TF-J, TF-M-SI, TF-M-SY, TF-MA, TF-ME, TF-N, TF-S, TF-SA, TF-SE, TF-U, TF-V

INCLUDES	
	<b>TF-SET-16:</b> Tuning Fork Holder for 16 tuning forks
	<b>TF-SET-16C:</b> Tuning Fork Case for 16 tuning forks

# TUNING FORKS & ACCESSORIES



Set, 7 pcs.  
**TF-SET-CHA-7 / TF-SET-CHA-7C**



Standard Pitch  
**TF-440**



Natural Pitch  
**TF-432**



**TFC-M**      **TFC-L**



**TFC-8**      **TFC-16**



**TF-HOLDER-7**



**TF-HOLDER-16**

## 3 TUNING FORK CHAKRA SET

- CONTAINS**
1. Root Chakra: TF-E-SY (Synodic Day)
  2. Sacral Chakra: TF-M-SY (Synodic Moon)
  3. Navel Chakra: TF-S (Sun)
  4. Heart Chakra: TF-E (Earth)
  5. Throat Chakra: TF-ME (Mercury)
  6. Brow Chakra: TF-V (Venus)
  7. Crown Chakra: TF-E-PL (Platonic Year)

- INCLUDES**
- TF-SET-CHA-7:**  
Tuning Fork Holder for 7 tuning forks
  - TF-SET-CHA-7C:**  
Tuning Fork Case for 8 tuning forks

## 4 STANDARD PITCH TUNING FORK

- SIZE** 5.4"  
**MATERIAL** Premium nickel plated steel  
**TUNING** 440 Hz  
**FEATURES** Handcrafted masterpiece made in Germany  
Ergonomic shaped cork handle  
Engraved logo and tuning info

## 5 NATURAL PITCH TUNING FORK

- SIZE** 5.4"  
**MATERIAL** Premium nickel plated steel  
**TUNING** 432 Hz  
**FEATURES** Handcrafted masterpiece made in Germany  
Ergonomic shaped cork handle  
Engraved logo and tuning info

## 6 TUNING FORK CASES

- SIZE** **TFC-M:** For max. 7.1" length  
**TFC-L:** For max. 8.3" length  
**TFC-8:** For 8 tuning forks  
**TFC-16:** For 16 tuning forks  
**MATERIALS** Inner material polyester  
Outer material leatherette  
**FEATURES** For safe and easy transportation

## 7 TUNING FORK HOLDERS

- SIZE** **TF-HOLDER-7:** For 7 tuning forks  
**TF-HOLDER-16:** For 16 tuning forks  
**MATERIAL** Beech wood  
**NOTICE** The tuning forks are not included

# PLANETARY TUNED ENERGY CHIMES



Set, 16 pcs.  
EC-SET-16



Set, 7 pcs.  
EC-SET-CHA-7



ECC-8

## 1 PLANETARY TUNED ENERGY CHIMES

**MATERIAL** Silver anodized aluminum alloy

**TUNING**

**EC-CH:** Chiron, 2765.76 Hz / F7

**EC-E:** Earth, 2177.60 Hz / C7#

**EC-E-PL:** Platonic Year, 2752.96 Hz / F7

**EC-E-SI:** Sidereal Day, 3115.36 Hz / G7

**EC-E-SY:** Synodic Day, 3106.88 Hz / G7

**EC-J:** Jupiter, 2937.28 Hz / F7#

**EC-M-SI:** Sidereal Moon, 3638.88 Hz / A7#

**EC-M-SY:** Synodic Moon, 3366.72 Hz / G7#

**EC-MA:** Mars, 2315.52 Hz / D7

**EC-ME:** Mercury, 2260.32 Hz / C7#

**EC-N:** Neptune, 3383.04 Hz / G7#

**EC-S:** Sun, 2019.52 Hz / B6

**EC-SA:** Saturn, 2365.60 Hz / D7

**EC-SE:** Sedna, 2905.60 Hz / F7#

**EC-U:** Uranus, 3317.76 Hz / G7#

**EC-V:** Venus, 3539.68 Hz / A7

**FEATURES** Handcrafted masterpiece made in Thailand  
Exact fine tuning  
Heat-branded logo and tuning info

**INCLUDES** Wooden beater

## 2 ENERGY CHIMES COMPLETE SET-UP

**CONTAINS** EC-CH, EC-E, EC-E-PL, EC-E-SI, EC-E-SY, EC-J, EC-M-SI, EC-M-SY, EC-MA, EC-ME, EC-N, EC-S, EC-SA, EC-SE, EC-U, EC-V

**INCLUDES** 16 wooden beaters

## 3 ENERGY CHIMES CHAKRA SET

**CONTAINS**

1. Root Chakra: EC-E-SY (Synodic Day)
2. Sacral Chakra: EC-M-SY (Synodic Moon)
3. Navel Chakra: EC-S (Sun)
4. Heart Chakra: EC-E (Earth)
5. Throat Chakra: EC-ME (Mercury)
6. Brow Chakra: EC-V (Venus)
7. Crown Chakra: EC-E-PL (Platonic Year)

**INCLUDES** 7 wooden beaters

## 4 ENERGY CHIME CASE

**SIZE** For 8 energy chimes

**MATERIALS** Inner material foam  
Outer material leatherette

**FEATURES** For safe and easy transportation



TINGSHA

TINGSHA-OR

TINGSHA-8



Medium  
B-M

X-Large  
B-XL

Medium  
BD-M

Small  
TD-S

Large  
TD-L



27 bars  
CH27WB



MARIMBULA

## 1 TINGSHAS

**SIZES** **TINGSHA:** 3.15"  
**TINGSHA-OR:** 3.15"  
**TINGSHA-8:** 2.68"

**MATERIAL** Special cast alloy

**FEATURES** Handcrafted masterpiece made in India  
Used for meditation

**SYMBOLS** **OR:** Ornamental  
**8:** 8 Luck Symbols (Ashtamangala)

**INCLUDES** Cotton bag

## 2 BELLS

**DIMENSIONS** **B-M:** Medium (3.5"); 355 g  
**B-XL:** X-Large (4.3"); 700 g  
**BD-M:** Medium (3.5"); 405 g

**MATERIAL** Special cast alloy

**FEATURES** Handcrafted masterpiece made in India  
Used for meditation

**INCLUDES** **BD-M:** Dorje

## 3 THUNDER DRUMS

**SIZES** **TD-S:** Small (7.48")  
**TD-L:** Large (9.84")

**MATERIAL** Synthetic body

**FEATURES** Durable construction  
Authentic thunder sounds

## 4 CHIMES, 27 BARS

**SIZE** 27 bars, single row

**MATERIALS** Jamjuree wood  
Gold anodized aluminum alloy

**FEATURE** Full sound with wide tonal spectrum

**COLOUR** **WB:** Walnut Brown

## 5 MARIMBULA

**SIZE** 23.5" W x 15.75" H x 8.25" D

**MATERIALS** Siam Oak (*Hevea brasiliensis* Muell.-Arg.)  
Steel tongues

**TUNING** f c G D F A d g

**FEATURE** Solid construction  
Heavy-duty rubber feet for a solid base

**COLOUR** Brown

**FINISH** Matte

# HARMONIC ART HANDPANS

1



Natural D, Black  
**HD1**



**NEW**

Natural Prime F, Black  
**HD1-F**



Equinox E, Black  
**HD2**



**NEW**

432 Hz Equinox E, Black  
**HD2-432**



Raga Desya Todi D#, Black  
**HD3**



Akebono F, Black  
**HD4**



Integral D, Black  
**HD5**



Dominant D, Black  
**HD6**



**NEW**

Expert D#, Black  
**HD6-EXPERT**



**NEW**

Free Integral C#, Black  
**HD7**



## 1 HARMONIC ART HANDPANS

**SIZE** 21.5" diameter; 10" height

**MATERIAL** High quality steel

**TUNING** **HD1:** Natural D/ A, A#, C, D, F, G, A

**HD1-F:** Natural Prime F/

A, A#, C, D, F, G, A

**HD2:** Equinox E/ G, B, C, D, E, F#, G

**HD2-432:** 432 Hz Equinox E/

G, B, C, D, E, F#, G

**HD3:** Raga Desya Todi D#/

G, A#, C, D, D#, F, G

**HD4:** Akebono F/ A#, C, C#, D#, F, F#, A#

**HD5:** Integral D/ A, A#, C, D, E, F, A

**HD6:** Dominant D/ A, C, D, E, F, G, A

**HD6-EXPERT:** Expert D#/

G#, A#, B, C#, D#, F#, G#

**HD7:** Free Integral C#/

G#, A, B, C#, D#, E, G#

**FEATURES** Handcrafted masterpiece  
Clear and pure soft sound with long sustain

Harmonic and balanced connection

**COLOUR** Black

**INCLUDES** Protection cover, bag and gloves



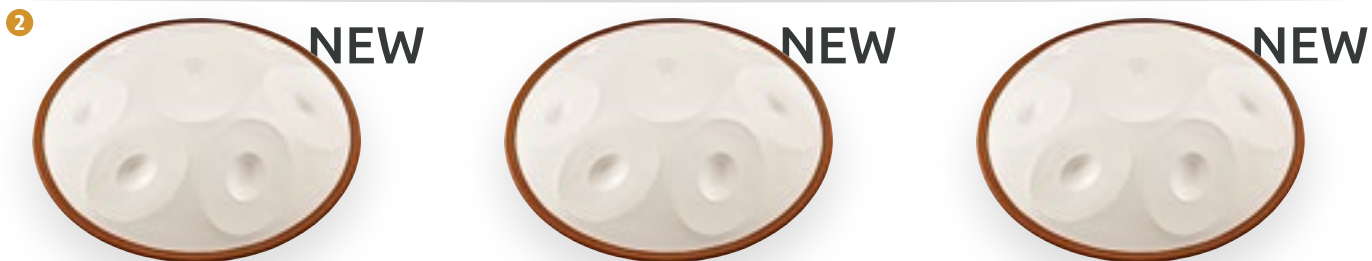

Natural D, White Jade  
**HD1-WJ**

Equinox E, White Jade  
**HD2-WJ**

Raga Desya Todi D#, White Jade  
**HD3-WJ**



Akebono F, White Jade  
**HD4-WJ**

Integral D, White Jade  
**HD5-WJ**

Dominant D, White Jade  
**HD6-WJ**



Natural D, Bronzite  
**HD1-B**

Equinox E, Bronzite  
**HD2-B**

Raga Desya Todi D#, Bronzite  
**HD3-B**



Akebono F, Bronzite  
**HD4-B**

Integral D, Bronzite  
**HD5-B**

Dominant D, Bronzite  
**HD6-B**

## 2 HARMONIC ART PRO HANDPANS

- SIZE** 21.5" diameter; 10" height
- MATERIAL** High quality steel
- TUNING**  
**HD1:** Natural D/ A, A#, C, D, F, G, A  
**HD2:** Equinox E/ G, B, C, D, E, F#, G  
**HD3:** Raga Desya Todi D#/ G, A#, C, D, D#, F, G  
**HD4:** Akebono F/ A#, C, C#, D#, F, F#, A#  
**HD5:** Integral D/ A, A#, C, D, E, F, A  
**HD6:** Dominant D/ A, C, D, E, F, G, A
- FEATURES**  
 Handcrafted masterpiece  
 Clear and pure soft sound with long sustain  
 Harmonic and balanced connection  
 Sustainable, maintenance-free coating for protection
- COLOURS**  
**B:** Bronzite  
**WJ:** White Jade
- INCLUDES** Protection cover, bag and gloves



# HANDPAN ACCESSORIES

**1** NEW



Evatek  
EV

**NEW**



Evatek Turtle  
EV-T

**2**



HDB

**3** NEW



HPS-5

**4** NEW



HPS

**5** NEW



HPWS

**6** NEW



HPR

**7**



HP-CW

## 1 HANDPAN HARDCASES

- SIZE** EV: 23.5" x 23.5" x 12"  
EV-T: 25" x 25" x 14"
- MATERIAL** Special ABS plastic and EVA material
- FEATURES** Ergonomic handle
- EV**  
100% waterproof  
Removable shoulders straps
- EV-T**  
Memory pad backpack  
Easy foam connection  
Maximum compatibility
- INCLUDES** EV  
Pocket Bag  
Carabiner

## 2 HANDPAN BAG

- SIZE** 25" diameter; 11.5" height
- MATERIALS** Heavy-duty nylon  
Synthetic fur

- FEATURES** Additional layer of synthetic fur for maximum protection  
Backpack straps  
Carrying grip
- COLOUR** Black

## 3 HANDPAN STAND, SMALL

- SIZE** Height adjustable from 22" up to 27"
- MATERIAL** Black powder coated steel
- FEATURES** Designed for Handpans and Steel Tongue Drums  
Also adjustable in the inclination

## 4 HANDPAN STAND

- SIZE** Height adjustable from 28" up to 39"
- MATERIAL** Black powder coated steel
- FEATURES** Designed for Handpans and Steel Tongue Drums  
Also adjustable in the inclination

## 5 WOOD HANDPAN STAND

- SIZE** 23" length; 14" height
- MATERIAL** Baltic Birch (*Betula pendula*)
- FEATURE** Handpan can be played in comfortable position

## 6 HANDPAN REST

- SIZE** 18.7" long; 6.9" height
- MATERIAL** Baltic Birch (*Betula pendula*)
- FEATURE** For easy storage

## 7 HARMONIC ART HANDPAN CARE WAX

- SIZE** 36 ml
- FEATURES** Prevents unwanted development of rust  
Keeps the steel looking as good as new and shiny  
Should be used on the playing surface only

# STEEL TONGUE DRUMS

1



A Minor, Black  
**STD1BK**



A Minor, Vintage Brown  
**STD1VB**



A Akebono, Black  
**STD2BK**



A Akebono, Vintage Brown  
**STD2VB**



G Major, Black  
**STD3BK**



G Major, Vintage Brown  
**STD3VB**

INCLUDED



2



**STDB**

## 1 STEEL TONGUE DRUMS

**SIZE** 12" W x 6.5" H x 12" D  
**MATERIAL** Black powder coated steel  
**TUNING** **STD1:** A Minor  
 A3/ C4, D4, E4, G4, A4, C5, D5  
**STD2:** A Akebono  
 A3/ B3, C4, E4, F4, A4, B4, C5  
**STD3:** G Major  
 G3/ A3, B3, D4, E4, G4, A4, B4  
**FEATURE** Rich, full-sound  
**COLOURS** **BK:** Black  
**VB:** Vintage Brown  
**INCLUDES** Bag  
 Steel Tongue Drum Mallet pair

## 2 STEEL TONGUE DRUM MALLETS

**SIZE** 11.25"  
**FEATURES** Designed to elicit full-bodied, rich tones  
 Textured grips provide firm control

# FRAME DRUMS

1



Endless Knot, 15"  
HOD15-EK



Flower of Life, 15"  
HOD15-FOL



Triskele, 15"  
HOD15-TR



Venus Flower, 15"  
HOD15-VF

2



Endless Knot, 16"  
HD16WB-EK



Flower of Life, 16"  
HD16WB-FOL



Triskele, 16"  
HD16WB-TR



Venus Flower, 16"  
HD16WB-VF

3



18"  
HD18WB

20"  
HD20WB



16"  
WD16WB

18"  
WD18WB

20"  
WD20WB

22"  
WD22WB

## 1 NATIVE AMERICAN-STYLE HOOP DRUMS

**SIZE** 15"  
**MATERIALS** Hand selected buffalo head  
Nylon lacing and grip  
**FEATURES** Warm and powerful sound  
Adjustable hand grip  
**SYMBOLS** **EK:** Endless Knot  
**FOL:** Flower of Life  
**TR:** Triskele  
**VF:** Venus Flower  
**INCLUDES** Leather padded wooden beater

## 2 HAND DRUMS

**SIZES** **HD16:** 16"  
**HD18:** 18"  
**HD20:** 20"  
**MATERIALS** Siam Oak (*Hevea brasiliensis* Muell.-Arg.)  
Hand selected goat head  
**FEATURES** Comfortable grip  
Warm, rich and resonating tones  
**SYMBOLS** **EK:** Endless Knot  
**FOL:** Flower of Life  
**TR:** Triskele  
**VF:** Venus Flower  
**COLOUR** **WB:** Walnut Brown

## 3 WAVE DRUMS

**SIZES** **WD16:** 16"  
**WD18:** 18"  
**WD20:** 20"  
**WD22:** 22"  
**MATERIALS** Siam Oak (*Hevea brasiliensis* Muell.-Arg.)  
Hand selected goat head and synthetic head  
**FEATURES** Sealable filling port allows you to control the amount of steel balls inside  
Two different drum heads  
Soothing sounds  
**COLOUR** **WB:** Walnut Brown



# MEINL ONLINE



facebook.com/**meinpercussionfanpage**

facebook.com/**meinlvivarhythm**

facebook.com/**ninopercussion**

facebook.com/**meinlsonicenergy**

instagram.com/**meinpercussion**

instagram.com/**meinlvivarhythm**

instagram.com/**ninopercussion**

instagram.com/**meinlsonicenergy**



youtube.com/**meinpercussion**

youtube.com/**meinlvivarhythm**

youtube.com/**ninopercussion**

youtube.com/**meinlsonicenergy**



twitter.com/**meinpercussion**

twitter.com/**meinlvivarhythm**

twitter.com/**ninopercussion**

twitter.com/**meinlsonic**



**meinpercussion.com**

**meinlvivarhythm.com**

**ninopercussion.com**

**meinlsonicenergy.com**



## DISCLAIMER

All features are subject to change without notice. Not responsible for typographic errors. No part of this book may be reprinted, reproduced, or included in any online service in any form in whole or in part, without the prior permission of MEINL.

© 2020 Roland Meinl Musikinstrumente GmbH & Co. KG

### ADVERTISING CONCEPT & DESIGN

Marcus Schickert [ercasdieagentur.de]

### CONTENT & DIRECTION

Hannes Auerochs

### PHOTOGRAPHY

Christian Habermeier, Sebastian Jäger, Angelika Jakobs  
[studio-waldeck.de]  
Miroslav Šmikmátor [smikmatorphoto.com]  
Adobe Stock / Kitja

### LITHOGRAPHY

Sven Mihm [mihm-werbung.de]

### GLOBAL HEADQUARTERS

Roland Meinl Musikinstrumente GmbH & Co. KG  
Musik-Meinl-Straße 1  
91468 Gutenstetten  
Germany

### US HEADQUARTERS

MEINL USA L.C.  
3427 Ambrose Avenue  
Nashville, TN 37207  
USA

### INVENTORS OF SELECTED PRODUCTS

Bill Saragosa  
Dany Moreno  
Gilson Batista Da Silveira  
José J. Cortijo  
Juan Carlos Melian  
Marcus Ralph De Mowbray  
Mark Allen Johnson  
Michael Buchner  
Reiko Guthschmidt  
Taku Hirano  
Torsten Franz

REMO®, Fiberskyn®, Nuskyn® and Skyndeeep®  
are registered trademarks of REMO® Inc.  
Used by permission.

This catalogue has been printed on  
climate neutral paper.

Printed in Germany M-CA301219



