





THE MEINL BOOK OF PERCUSSION 2021



MEIN PERCUSSION

THE ULTIMATE SELECTION
OF PERCUSSION INSTRUMENTS



CREATIVE DRUM CIRCLE
INSTRUMENTS FOR EVERYONE

MEIN VIVA RHYTHM



MUSICAL INSTRUMENTS
DESIGNED FOR EARLY EDUCATION

MEIN PERCUSSION



SOUND THERAPY AND
PLANETARY TUNED INSTRUMENTS

MEIN SONIC ENERGY





B	
Bags	96
Blocks	47 / 67
Bongos	40
Bongo Cajons	12 / 14
Brushes/Beaters	15 / 21 / 84

C	
Cabasas	68
Caixas	65
Cajons	08
Cajons, Bass	13
Cajons, Pickup	05
Cajons, Slaptop	12
Cajons, Snare	10 / 12 / 14
Cajons, String	08 / 14
Cajon Add-Ons	18
Cajon Drum Sets	05 / 17
Cajon Pedals	15
Candela Percussion Cymbals	83
Castanets	69
Chimes	72
Ching Rings	54
Claves	69
Congas	30
Cowbells	46

D	
Darbukas	76
Didgeridoos	80
Djembes	22
Djembe, Pickup	03
Djembes, Synthetic	22
Djembes, Wood	26
Doumbeks	77

F	
Foot Percussion	20
Foot Percussion, Pickup	02
Frame Drums	74

G	
Güiras / Güiros	67

H	
Hand Drums	74
Hand Percussion	67
Hardware	92

I	
Ibo Drums	78

J	
Jingle Sticks	52

K	
Kalimbas	68
Kalimba, Pickup	03

M	
Mallets	84
Maracas	61

P	
Pandeiros	48
Pickup Accessories	04
Pickup Instruments	02

R	
Rainmakers / Rainsticks	82
Ritual Drums	78
Riq Drum	48

S	
Samba	62
Shakers	56 / 66
Shekeres	79
Sound Effects	70
Stands	86
Sticks / Scrapers	84
Stomp Boxes	02
Surdos	62

T	
Tables	90
Tamborims / Tampeiro	65
Tambourines	49 / 56
Tamburello	51
Timbales	44
Triangles	66 / 70

PICKUP INSTRUMENTS

1 FIVE DIGITAL PRE-PROGRAMMED PERCUSSION SAMPLES AND ONE CUSTOM SAMPLE

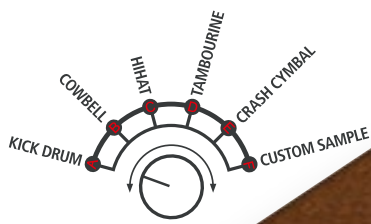

Digital
MPDS1

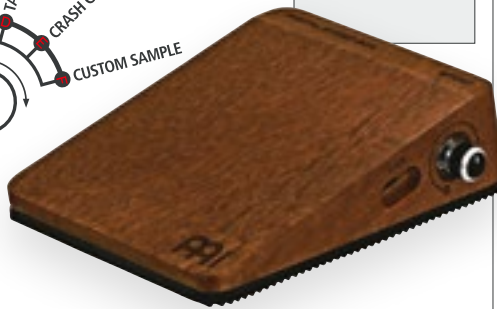

CREATES A FOOT STOMPING ANALOG SIGNAL



Analog
MPS1



2 NEW

WITH DIGITAL PERCUSSION STOMP BOX



Set
MPDS1-SET

WITH ANALOG PERCUSSION STOMP BOX



Set
MPS1-SET

3



MPSM

1 PERCUSSION STOMP BOXES

MATERIAL Solid Mahogany body
FEATURES Perfect for percussionists and multi-instrumentalists; 1/4" input and output jacks

MPDS1

Five digital pre-programmed percussion samples and one custom sample; Built-in Piezo trigger with volume control

MPS1

Creates a foot stomping analog signal; Built-in Piezo pickups with volume control

INCLUDES

L-shaped soft foam beater

2 STOMP BOX SETS

CONTAINS 1 x Stomp Box Mount (MPSM)
1 x Bassbox/Snarebox Pedal (TMBP)
1 x L-shaped soft foam beater (BBB2)
MPDS1-SET: Digital Stomp Box (MPDS1)
MPS1-SET: Analog Stomp Box (MPS1)

FEATURES

Real bass drum feel in a neat, Portable package; Perfect for soloists, percussionists and musicians on the move

MPDS1-SET

Easily switch between 5 pre-programmed samples, or upload one of your own!

MPS1-SET

Easy connectivity with 1/4" jack input and output

3 STOMP BOX MOUNT

MATERIAL Baltic Birch (*Betula pendula*)

FEATURES

Play your MEINL Stomp Box with the feel of a bass drum; Attach any common bass drum pedal; Works with all MEINL Stomp Boxes; Baltic birch construction; Use the MEINL L-Shaped beater to get flush contact (model BBB2 – sold separately)

FINISH

Black

PICKUP BASSBOX & PICKUP SNAREBOX 4 5

FEATURES

Piezo pickup with high quality output jack; Playable with our BassBox/SnareBox pedal, as well as any other common bass drum pedal; Aluminum rail to mount any common bass drum pedal; Forward facing sound port

COLOUR

Black

FINISH

Matte

4 PICKUP BASSBOX

SIZE

17 1/2" W x 6 3/4" H x 11 3/4" D

MATERIAL

Resonating body: Baltic Birch (*Betula pendula*)

FEATURE

Immense bass sound that's perfect for any musician, including singer/songwriters and guitarists

INCLUDES

L-shaped soft foam beater

4 IMMENSE BASS SOUND



Baltic Birch
PBASSBOX

L-SHAPED SOFT FOAM BEATER INCLUDED

5 CRISP SNARE SOUND



Baltic Birch
PSNAREBOX

L-SHAPED FELT BEATER INCLUDED

6 PICKUP SYSTEM WITH VOLUME CONTROL



Medium
KA9P-AB

7 **NEW** STANDARD CAJON BRUSHES INCLUDED



TMPPCS

8 **NEW**



BARNWOOD

12"
PADJ12-BW

9 **NEW** A WHOLE PERCUSSION KIT IN A BOX



FX20



5 PICKUP SNAREBOX

SIZE 7 1/2" W x 7 1/2" H x 13" D
MATERIAL Baltic Birch (*Betula pendula*)
FEATURE Crisp snare sound that's perfect for any musician, including singer/songwriters and guitarists
INCLUDES L-shaped felt beater

6 PICKUP KALIMBA

SIZE Medium
MATERIALS Chrome plated steel
 Siam Oak (*Hevea brasiliensis* Muell.-Arg.)
TUNING a', c'', c', a', A, f', e', e', b'
FEATURES Pickup system with external volume control; Wah-wah effect
COLOUR **AB:** Antique Brown

7 PROFESSIONAL PICKUP CAJON SNARE

SIZE 13" W x 6" H x 13" D
MATERIALS Resonating body: MDF
 Playing surface: American White Ash (*Fraxinus Americana* L.)
FEATURES Dual internal sets of snares; Snare throw-off switch; Piezo pickup with bass and snare tone control; Textured playing surface; Works with any snare basket stand
INCLUDES Standard Cajon Brushes (SB305)

8 PICKUP ALPINE SERIES DJEMBE

SIZE 12" diameter, 24" tall
MATERIALS Synthetic shell
 Synthetic head
FEATURES 100% synthetic djembe; Piezo pickup and volume control; Mechanically tuned head; Great for outdoor performances
FINISH **BW:** Barnwood

9 EFFECTS PEDAL

MATERIALS ABS; Steel
FEATURES Ideal for multi-instrumentalists and percussionists; Ten pre-programmed percussion samples and ten custom samples; Weighted body for a sturdy feel; Highly dynamic pedal with smooth spring back and no sound interference; Includes micro SD card and power supply with international adapters
SOUNDS 0 - Kick Bass; 1 - Soft Kick; 2 - 808 Bass; 3 - 808 Snare; 4 - HiHat; 5 - Clave; 6 - Hand Clap; 7 - Cowbell; 8 - Straight Tambourine; 9 - Shaker

PICKUP ACCESSORIES



MIC-PERC



PA-CAJ



MMCS



MPMCC



CMS



MPMGR



**MPIC-5 / MPIC-10 /
MPIC-15 / MPIC-20 / MPIC-30**



Set, 5 pcs.
MPICS1

1 PERCUSSION MICROPHONE

FEATURES Low-profile condenser microphone with adhesive backing; Safely and securely sticks to the inside of acoustic percussion instruments; Great for cajons, congas, djembes or frame drums; Includes eighth-inch cable to quarter-inch adapter

2 CAJON PREAMP

FEATURES Robust Cajon Pickup/Preamp; Wide range tone control; High-quality signal output; Fits most cajons

3 MINI CAJON SPEAKER

SIZE 5 3/4" W x 8 3/4" H x 5 3/4" D
MATERIALS Resonating body: 5-Ply (6 mm) Baltic Birch (*Betula pendula*)
Frontplate: Baltic Birch (*Betula pendula*)

FEATURES Miniature MEINL cajon that functions as a speaker; Listen to your favorite music or podcast; Supports wireless, USB and auxiliary connection; Great gift idea for percussionists

4 CAJON MICROPHONE STAND

MATERIAL Black powder coated aluminum
FEATURES Round base for compact setup; Solid construction; Height adjustable

5 MICROPHONE CAJON CLAMP

MATERIAL Steel
FEATURES Solid steel frame for maximum durability; Adjustable clamping mechanism compatible with all common cajon sound ports; Foam padding ensures quiet recording and protects your cajon's finish; Sliding mount fits all conventional microphone types

6 MERGER

MATERIAL Aluminum
FEATURES Combine multiple percussion audio signals into one output; Contains 6 inputs, 1 XLR output and 1 AUX input; Crystal clear signal

7 INSTRUMENT CABLES

SIZES **MPIC-5:** 5 ft / 1.5 m
MPIC-10: 10 ft / 3 m
MPIC-15: 15 ft / 4.5 m
MPIC-20: 20 ft / 6 m
MPIC-30: 30 ft / 9 m

FEATURES Great for all MEINL Percussion pickup instruments and Stomp Boxes; Flexible extra-thick braided nylon jacket avoids tangles and handling noise; 8 mm diameter with high-quality 1/4" straight connectors; Wire gauge: 24 AWG

PICKUP CAJONS



PICKUP ACCESSORIES & CAJONS



Set
PBASSCAJ-KIT



PBASSCAJ



PBC1B

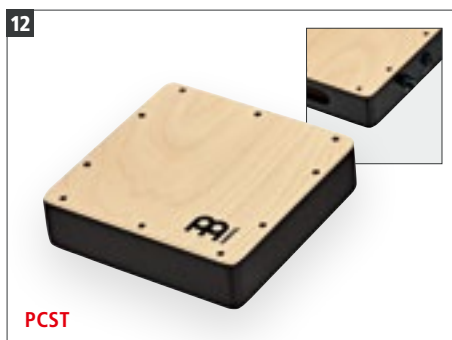

PCST

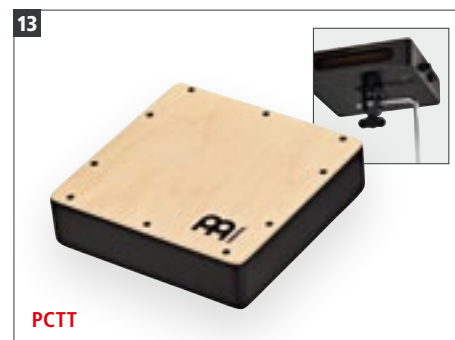

PCTT



8 COCKTAIL CAJON INSTRUMENT CABLE SET

CONTAINS 4 x 5 ft Instrument Cable (MPIC-5)
1 x 30 ft Instrument Cable (MPIC-30)
FEATURES 5-piece MEINL Percussion Instrument Cable set for the MEINL Cocktail Cajon Kit

9 COCKTAIL CAJON KIT

CONTAINS Cocktail Cajon; Tom Tap; Snare Tap; Bongo Cajon Tap; Husk Brush (SB307); Foot Pedal (TMBP); Pedal Beater (CPB4); 3 x L-shaped rod (MC-R5); Splitter
FEATURES Create cocktail-style cajon kit or percussion set ups; Each drum is equipped with a Piezo pickup and high-quality output jack

10 COCKTAIL CAJON

SIZE 11 3/4" W x 19 3/4" H x 11 3/4" D
MATERIALS Resonating body: 7-Ply (9 mm) Baltic Birch (*Betula pendula*)
Frontplate: Baltic Birch (*Betula pendula*)
FEATURES Baltic birch cajon with forward facing ports and no snares for more bass; Bass drum pedal mount; Three clamps to attach percussion rods or cymbal arms (rods and arms sold separately); Piezo pickups for extra amplification

11 PICKUP BONGO CAJON

MATERIAL Baltic Birch (*Betula pendula*)
FEATURES High and low note playing areas; Piezo pickup and quarter-inch output jack

PICKUP CAJON TAPS 12 13

SIZE 10 3/4"
MATERIAL Baltic Birch (*Betula pendula*)
FEATURES Piezo pickup, quarter-inch output jack and volume knob; Standard eye bolt mount to add to your cajon set up or percussion rig; Ideal for acoustic shows

12 PICKUP CAJON SNARE TAP

FEATURE Hollow wooden body with internal snare produces a crisp snare drum sound

13 PICKUP CAJON TOM TAP

FEATURE Hollow wooden body produces a high-pitched tom sound

PICKUP CAJONS

1

PIEZO PICKUP WITH VOLUME AND TONE CONTROL



SOLEÁ LINE

Dark Olive Burst
PAESLDOB

2

NEW



Baltic Birch
PWC100B

Makah-Burl
PWCP100MB



3

NEW



Baltic Birch
PSC100NT

Baltic Birch
PSC100B

4

NEW



Baltic Birch
PJC50B



1 ARTISAN EDITION PICKUP CAJON, SOLEÁ LINE

SIZE 11 1/4" W x 19" H x 11 3/4" D

MATERIALS Resonating body: 9-Ply (12 mm) Baltic Birch (*Betula Pendula*)
Frontplate: Dark Olive Burst

FEATURES Piezo pickup with volume and tone control; Two sets of 4 pre-tuned strings; Rounded corners and thumb notches for optimal playing comfort and sound; Ergonomically rounded frontplate with convex contact; Bass reflex system

2 PICKUP WOODCRAFT SERIES CAJONS

SIZE **PWCP100MB** (Woodcraft Professional) 11 3/4" W x 19 3/4" H x 12" D
PWC100B (Woodcraft) 11 3/4" W x 19 3/4" H x 12" D

MATERIALS Resonating body: Baltic Birch (*Betula pendula*)
PWCP100MB (Woodcraft Professional)
Frontplate: Makah-Burl
PWC100B (Woodcraft)
Frontplate: Baltic Birch (*Betula pendula*)

FEATURES Three Piezo pickups for snare and bass sounds; Baltic birch construction; Custom micro-coiled steel cajon strings; Rubber feet and rear sound port

COLOURS **PWCP100MB**
Resonating body: Black
PWC100B
Resonating body: Natural

FEATURES Three Piezo pickups for snare and bass sounds; Baltic birch construction; Dual internal fixed snare wires; Rubber feet and rear sound port

COLOURS **PSC100B**
Resonating body: Black
PSC100NT
Resonating body: Natural

3 PICKUP SNARECRAFT SERIES CAJONS

SIZE 11 3/4" W x 19 3/4" H x 11 3/4" D

MATERIALS Resonating body: Baltic Birch (*Betula pendula*)
Frontplate: Baltic Birch (*Betula pendula*)

4 PICKUP JAM CAJON

SIZE 10 1/2" W x 15" H x 10" D

MATERIALS Resonating body: Baltic Birch (*Betula pendula*)
Frontplate: Baltic Birch (*Betula pendula*)

FEATURES Compact size; Dual internal fixed snare wires; Piezo pickup with volume control; Produces punchy bass and cutting snare; High-quality output jack

COLOUR Natural

5 NEW



Birch Wood
MPDC1

DIGITAL CAJON FOR EXPANDED SOUND
OPTIONS AND SILENT PRACTICE

DIGITAL CAJON SOUNDS

- 0 - MEINL Subwoofer Cajon + MEINL Tambourine
- 1 - MEINL Snarecraft Cajon + MEINL Splash Cymbal
- 2 - MEINL Cantina Line Artisan Cajon + MEINL Closed Hihat Cymbal
- 3 - MEINL Slaptop Cajon + Hand Clap
- 4 - MEINL Woodcraft Cajon + MEINL Crash Cymbal
- 5 - Rock Drum Kit + MEINL Closed Hihat Cymbal
- 6 - Drum Machine + MEINL Ride Cymbal
- 7 - MEINL Marathon® Classic Congas
- 8 - MEINL Fibercraft Bongos + MEINL Percussion Block
- 9 - MEINL Diego Galé Signature Timbales + MEINL Steel Craft Cowbell

PICKUP CAJONS

6 NEW



Baltic Birch
MPSCAJ

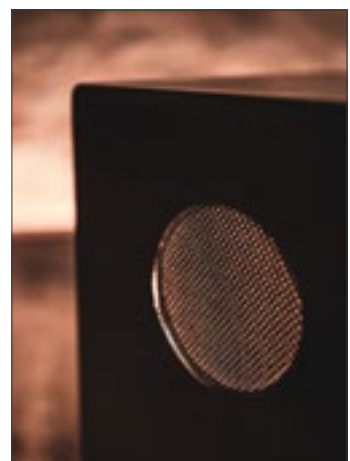

7



Baltic Birch
PSUBCAJ6B

VERTICAL FORWARD-FACING
SUBWOOFER SOUND PORTS

8



Walnut
PTOPCAJ2WN

THE PICKUP TURBO SLAPTOP CAJON
IS BIGGER FOR MORE VOLUME

INDIVIDUAL SNARE, BASS,
AND TONE CONTROL



Mahogany
PTOPCAJ4MH-M



5 DIGITAL CAJON
SIZE 12" W x 20" H x 12" D
MATERIALS Resonating body: Birch Wood
 Playing surface: Open cell acoustic foam
FEATURES Digital Cajon for expanded sound options and silent practice; Four rubber trigger pads in a natural cajon playing position; Ten pre-programmed digital sound combinations of MEINL cajons, percussion instruments, drums and cymbals; Perfect for plugged-in settings
INCLUDES Power supply; Foot switch
COLOUR Black

6 SPEAKER CAJON
SIZE 11 3/4" W x 19 3/4" H x 11 3/4" D
MATERIALS Resonating body: Baltic Birch (*Betula pendula*)
 Frontplate: Baltic Birch (*Betula pendula*)

FEATURES Practice to music or incorporate loops in your performances; Two 4.5" 20-watt speakers; Full size 100% Baltic Birch cajon with dual internal fixed sets of snares; Supports wireless connection with your phone; Control panel on the cajon to toggle through music and adjust your volume
INCLUDES Micro SD card
COLOUR Resonating body: Black

7 PICKUP VERTICAL SUBWOOFER CAJON
SIZE 15 1/2" W x 19 1/4" H x 11 3/4" D
MATERIALS Resonating body: Eco-friendly medium density fiberboard
 Frontplate: Baltic Birch (*Betula pendula*)
FEATURES Vertical forward-facing subwoofer sound ports for enhanced bass notes; Piezo pickup with volume and tone control; Dual internal fixed snare wires

8 PICKUP SLAPTOP CAJONS (PATENTED)
SIZES **PTOPCAJ2WN** (Turbo Slaptop) 14 1/2" W x 10" H x 5 3/4" D
PTOPCAJ4MH-M 15 1/2" W x 8 1/2" H x 7 1/2" D
MATERIALS **PTOPCAJ2WN** (Turbo Slaptop) Resonating body: Baltic Birch (*Betula pendula*)
 Playing surface: Walnut (*Juglans regia* L.)
PTOPCAJ4MH-M Resonating body: Eco-friendly medium density fiberboard
 Playing surface: Mahogany
FEATURES Passive pickup system with high quality output jack; Individual snare, bass, and tone control; Playing surface with dual internal fixed snare wires; Forward facing sound ports
PTOPCAJ2WN (Turbo Slaptop) Snares on both sides

ARTISAN EDITION CAJONS

JOSÉ HERNÁNDEZ DÍAZ

also known as 'Pepote' – was born in Huelva (Spain) in November 1976. He inherited his passion for wood from his father and grandfather, both of whom were aficionados of woodwork and model aeroplanes.

He first came across the Cajon at the age of 13 while watching a Paco de Lucia concert on television. Inspired to make his own, he soon started receiving commissions from friends and acquaintances when they realised that the Cajon was virtually impossible to get hold of in Spain.

Pepote began taking these instruments to local shops in his city when he was just 15 years old. This marked the start of his woodwork training, where he focused on the production of musical instruments by studying techniques for making ancient musical instruments and guitars while also completing his studies in industrial furniture design.

Since then, he has been continually developing the instrument and relentlessly perfecting his craft. He came up with an aesthetic based on comfort, tried and tested more than 30 different kinds of wood for construction, created a special unbreakable string for the Cajon and tried 20 different kinds of varnish for the finish. The list goes on. Everything he does revolves around getting the best possible sound out of the instrument and providing the ultimate peace of mind for the percussionist.



THE NAME BEHIND

1

MARTINETE LINE



Brazilian Ironwood with Ukola Woodframe
AEMLBI

2

FANDANGO LINE



Indian Heartwood
AEFLIH

3

SEGURIYA LINE



Indian Heartwood
AESELIH

3

SEGURIYA LINE



Canyon-Burl
AESELCB

4

CANTINA LINE

NEW



Limba
AECLLI



Walnut
AECLWN

UNIQUELY SHAPED BODY FOR BROAD BASS SPECTRUM

5

BASS REFLEX SYSTEM

BULERÍA LINE

Lava-Burl
AEBLLB

Mongoy
AEBLMY

ARTISAN EDITION CAJONS

1 2 3 4 5 6 7

FEATURES Rounded corners and thumb notches for optimal playing comfort and sound
Ergonomically rounded frontplate with convex contact
Specially formulated soft rubber feet
Martinete, Fandango, Seguriya, Cantina Line:
Decorative wood inlay
Extra thick wooden sound port ring for compression
Two tuning screws to adjust the tension for each set of strings
Pop filter on soundhole
Seguriya, Cantina, Soleá, Bulería, Tango Line:
Elegant heat-branding on resonating body

1 MARTINETE LINE

SIZE 11 1/2" W x 19" H x 12 3/4" D
MATERIALS Resonating body: Solid Wood (15 mm)
Tulip Poplar (*Liriodendron tulipifera*)
Frontplate: Brazilian Ironwood (*Phoebe porosa*) with Ukola Woodframe
FEATURES Two sets of 10 adjustable strings (Separately per side)
6 specially formulated soft rubber feet
INCLUDES Tuning key

2 FANDANGO LINE

SIZE 11 1/2" W x 19" H x 12" D
MATERIALS Resonating body: Solid Wood (15 mm)
Tulip Poplar (*Liriodendron tulipifera*)
Frontplate: Indian Heartwood
FEATURES Two sets of 8 adjustable strings (Separately per side)
6 specially formulated soft rubber feet
INCLUDES Tuning key

3 SEGURIYA LINE

SIZE 11 1/4" W x 19" H x 11 3/4" D
MATERIALS Resonating body: 9-Ply (12 mm)
Baltic Birch (*Betula Pendula*)
AESELCB Frontplate: Canyon-Burl
AESELIH Frontplate: Indian Heartwood
FEATURES Two sets of 8 adjustable strings (Separately per side)
INCLUDES Tuning key

4 CANTINA LINE

SIZE **AECLLI**
11 1/4" W x 19" H x 11 3/4" D
AECLWN
12 1/2" W x 18 1/2" H x 12 1/2" D
MATERIALS Resonating body: 9-Ply (12 mm)
Baltic Birch (*Betula Pendula*)
AECLLI Frontplate: Limba
AECLWN Frontplate: Walnut

ARTISAN EDITION & WOODCRAFT CAJONS



6 **SOLEÁ LINE** **BASS REFLEX SYSTEM**

Ebony Burst
AESLEYB

Dark Red Burst
AESLRB

Espresso Burst
AESLEB



STRING CAJONS

7 **TANGO LINE**

Brown Eucalyptus
AETLBE

Grey Eucalyptus
AETLGE

Light Eucalyptus
AETLLE

Limba
AETLLI

8

Mahogany
WCP100MH

Makah-Burl
WCP100MB

9 **ROUNDED CORNERS FOR ADDED COMFORT**

Baltic Birch
WC100B

Espresso Burst
WC100EB

FEATURES **AECCLI**
Forward projecting sound port; Two sets of 6 adjustable strings (Separately per side)

AECLWN
Two sets of 8 adjustable strings from the top (Separately per side)

INCLUDES Tuning key

5 BULERÍA LINE

SIZE 11 1/4" W x 19" H x 11 3/4" D

MATERIALS Resonating body: 9-Ply (12 mm)
Baltic Birch (*Betula Pendula*)
AEBLLB Frontplate: Lava-Burl
AEBLMY Frontplate: Mongoy

FEATURES Two sets of 5 adjustable strings (Separately per side)
Tuning screw to adjust string tension
Pop filter on soundhole
Bass reflex system

INCLUDES Tuning key

6 SOLEÁ LINE

SIZE 11 1/4" W x 19" H x 11 3/4" D

MATERIALS Resonating body: 9-Ply (12 mm)
Baltic Birch (*Betula Pendula*)
AESLEB Frontplate: Espresso Burst
AESLEYB Frontplate: Ebony Burst
AESLRB Frontplate: Dark Red Burst

FEATURES Two sets of 4 pre-tuned strings
Bass reflex system

7 TANGO LINE

SIZE 11 1/4" W x 19" H x 11 3/4" D

MATERIALS Resonating body: 7-Ply (9 mm)
Baltic Birch (*Betula Pendula*)
AETLBE Frontplate: Brown Eucalyptus
AETLGE Frontplate: Grey Eucalyptus
AETLLE Frontplate: Light Eucalyptus
AETLLI Frontplate: Limba

FEATURES Two sets of 3 pre-tuned strings

WOODCRAFT CAJONS **8** **9**

SIZE 11 3/4" W x 19 3/4" H x 12" D

FEATURES Custom micro-coiled steel cajon strings
Baltic birch construction
Rounded corners for added comfort
Rubber feet and rear sound port

8 WOODCRAFT PROFESSIONAL CAJONS

MATERIALS Resonating body: 9-Ply (12 mm)
Baltic Birch (*Betula pendula*)
WCP100MB Frontplate: Makah-Burl
WCP100MH Frontplate: Mahogany

9 WOODCRAFT CAJONS

MATERIALS Resonating body: 7-Ply (9 mm)
Baltic Birch (*Betula pendula*)
WC100B Frontplate: Baltic Birch (*Betula pendula*)
WC100EB Frontplate: Espresso Burst

SNARECRAFT CAJONS

1 FOOT ACTIVATED SNARE SWITCH



American White Ash
SCP100AWA

SNARE SWITCH KNOB



Walnut
SCP100WN

2



Almond Birch
SC80AB

Almond Birch
SC100AB



Baltic Birch
SC80AB-B

Baltic Birch
SC100AB-B

NEW



Burl Wood
SC80BW

Burl Wood
SC100BW



Heart Ash
SC80HA

Heart Ash
SC100HA



SC80 HEIGHT 18"
SC100 HEIGHT 19 3/4"

1 SNARECRAFT PROFESSIONAL CAJONS

SIZE 11 3/4" W x 19 3/4" H x 12" D

MATERIALS Resonating body: 9-Ply (12 mm)
Baltic Birch (*Betula pendula*)
SCP100AWA
Frontplate: American White Ash (*Fraxinus Americana* L.)
SCP100WN
Frontplate: Walnut

FEATURES Adjustable snare for both Flamenco and Peruvian styles
Baltic birch construction
Rounded corners for added comfort
Rubber feet and rear sound port
SCP100AWA
Equipped with a foot activated snare switch
SCP100WN
Equipped with a snare switch knob on the side of the cajon

2 SNARECRAFT CAJONS

SIZES **SC80:** 11 3/4" W x 18" H x 11 3/4" D
SC100: 11 3/4" W x 19 3/4" H x 11 3/4" D

MATERIALS **SC80AB, SC100AB**
Resonating body: 7-Ply (9 mm)
Baltic Birch (*Betula pendula*)
Frontplate: Almond Birch (*Betula pendula*)
SC80AB-B, SC100AB-B
Resonating body: 7-Ply (9 mm)
Almond Birch (*Betula pendula*)
Frontplate: Baltic Birch (*Betula pendula*)
SC80B, SC100B
Resonating body: 7-Ply (9 mm)
Baltic Birch (*Betula pendula*)
Frontplate: Baltic Birch (*Betula pendula*)
SC80BW, SC100BW
Resonating body: 7-Ply (9 mm)
Baltic Birch (*Betula pendula*)
Frontplate: Burl Wood

SC80HA, SC100HA

Resonating body: 7-Ply (9 mm)
Baltic Birch (*Betula pendula*)
Frontplate: Heart Ash
FEATURES Dual internal fixed snare wires
Baltic birch construction
Rounded corners for added comfort
Rubber feet and rear sound port

JAM & MINI CAJONS



SNARE CAJONS

1



Almond Birch
JC50AB



Baltic Birch
JC50AB-B



Baltic Birch
JC50B

NEW



Burl Wood
JC50BW

JC50 HEIGHT 15"



Heart Ash
JC50HA

2



Almond Birch
MC1AB



Baltic Birch
MC1AB-B



Baltic Birch
MC1B

NEW



Burl Wood
MC1BW



Dark Eucalyptus
MC1DE



Heart Ash
MC1HA

MC1 HEIGHT 8 3/4"



MINIATURE SIZE OF A CAJON WITH
INTERNAL FIXED SNARE WIRES

1 JAM CAJONS

SIZE 10 1/2" W x 15" H x 10 1/4" D

MATERIALS **JC50AB**

Resonating body: 7-Ply (9 mm)

Baltic Birch (*Betula pendula*)

Frontplate: Almond Birch

(*Betula pendula*)

JC50AB-B

Resonating body: 7-Ply (9 mm)

Almond Birch (*Betula pendula*)

Frontplate: Baltic Birch (*Betula pendula*)

JC50B

Resonating body: 7-Ply (9 mm)

Baltic Birch (*Betula pendula*)

Frontplate: Baltic Birch (*Betula pendula*)

JC50BW

Resonating body: 7-Ply (9 mm)

Baltic Birch (*Betula pendula*)

Frontplate: Burl Wood

FEATURES

JC50HA

Resonating body: 7-Ply (9 mm)

Baltic Birch (*Betula pendula*)

Frontplate: Heart Ash

Compact size

Baltic birch construction

Dual internal fixed snare wires

Rubber feet and rear sound port

2 MINI CAJONS

SIZE 5 3/4" W x 8 3/4" H x 5 3/4" D

MATERIALS **MC1AB**

Resonating body: 5-Ply (6 mm)

Baltic Birch (*Betula pendula*)

Frontplate: Almond Birch

(*Betula pendula*)

MC1AB-B

Resonating body: 5-Ply (6 mm)

Almond Birch (*Betula pendula*)

Frontplate: Baltic Birch (*Betula pendula*)

FEATURES

MC1B

Resonating body: 5-Ply (6 mm)

Baltic Birch (*Betula pendula*)

Frontplate: Baltic Birch (*Betula pendula*)

MC1BW

Resonating body: 5-Ply (6 mm)

Baltic Birch (*Betula pendula*)

Frontplate: Burl Wood

MC1DE

Resonating body: 5-Ply (6 mm)

Baltic Birch (*Betula pendula*)

Frontplate: Dark Eucalyptus

MC1HA

Resonating body: 5-Ply (6 mm)

Baltic Birch (*Betula pendula*)

Frontplate: Heart Ash

Internal fixed snare wires

Miniature size

Birch construction

Great gift idea

SLAPTOP, BONGO & TRAVEL CAJONS

1

VIDALITA LINE



Palo Santo, satin
AEVLPS



3

CONTRASTING PLAYING SURFACES ON OPPOSITE SIDES



Baltic Birch, matte
HOPCAJ3NT



4

INTERNAL SNARE WIRES



Natural/Ebony Black, matte
BCA2NT/EBK-M

TWO DIFFERENT SIZED CHAMBERS ENABLE AN AUTHENTIC BONGO EFFECT



Super Natural, matte
BCA1SNT-M



2

COMFORTABLE DESIGN FOR A MORE UPRIGHT PLAYING STYLE (PATENTED)



Makah-Burl, matte
TOPCAJ1MB



Espresso Burst, matte
TOPCAJ1EB



THE TURBO SLAPTOP CAJONS ARE BIGGER FOR MORE VOLUME



Walnut, matte
TOPCAJ2WN



Mahogany, matte
TOPCAJ2MH

5

BACK



SOUND PORT FOR CLEAR PROJECTION

Black, matte
TCAJ1BK



1 ARTISAN EDITION SLAPTOP CAJON, VIDALITA LINE

SIZE 17 3/4" W x 10" H x 12 1/2" D
MATERIALS Resonating body: 6 mm birch plywood; Playing surface: Palo Santo (*Bursera graveolens*)
FEATURES Enlarged Baltic Birch body with upward facing front port for deep bass; Eight pre-tuned custom micro-coiled steel cajon strings; Palo Santo playing surface with sensitive snare effect; Made in Spain

2 SLAPTOP CAJONS (PATENTED)

SIZES **TOPCAJ1**
14 1/2" W x 8 3/4" H x 5 3/4" D
TOPCAJ2 (Turbo Slaptop)
14 1/2" W x 10" H x 5 3/4" D

MATERIALS **TOPCAJ1EB**

Resonating body: Baltic Birch (*Betula pendula*); Playing surface: Espresso Burst

TOPCAJ1MB

Resonating body: Eco-friendly medium density fiberboard;

Playing surface: Makah-Burl

TOPCAJ2MH (Turbo Slaptop)
Resonating body: Baltic Birch (*Betula pendula*); Playing surface: Mahogany

TOPCAJ2WN (Turbo Slaptop)
Resonating body: Eco-friendly medium density fiberboard;

Playing surface: Walnut (*Juglans regia* L.)

FEATURES

Comfortable upright playing style; Forward facing sound ports; Dual internal fixed snare wires; Deep bass and cutting slap tones
TOPCAJ2 (Turbo Slaptop)
Snares on both sides

3 HYBRID SLAPTOP CAJON

SIZE 14 1/2" W x 10" H x 5 3/4" D
MATERIAL Baltic Birch (*Betula pendula*)
FEATURES Comfortable and unique X-design; Forward sound projection; Dual internal fixed snare wires for a snare cajon sound on one side; Bongo cajon sound on the opposite side

4 BONGO CAJONS

SIZE 15 3/4" W x 6 3/4" H x 7 1/4" D
MATERIAL Siam Oak (*Hevea brasiliensis* Muell.-Arg.)
FEATURES High and low pitch playing surface; Compact size and light weight
BCA2NT/EBK-M: Dual internal fixed snare wires

5 TRAVEL CAJON

SIZE 11 3/4"
MATERIAL Siam Oak (*Hevea brasiliensis* Muell.-Arg.)
FEATURES Internal snare wires; Compact design

BASS CAJONS

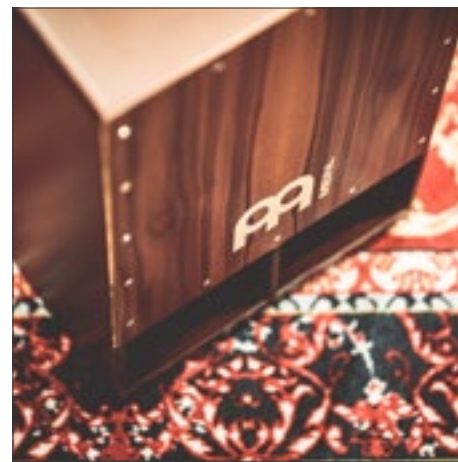

CAJONS

1 JUMBO ARCH BASS CAJON

SIZE 16" W x 19 3/4" H x 13 1/2" D
MATERIALS Resonating body: Siam Oak (*Hevea brasiliensis* Muell.-Arg.); Frontplate: Maple
FEATURES Arched sides and back for low note development; Extra wide dimensions; Dual internal fixed snare wires; Enhanced boomy and punchy bass sounds

2 ARCH BASS CAJON

SIZE 15 1/4" W x 18" H x 12" D
MATERIALS Resonating body: Siam Oak (*Hevea brasiliensis* Muell.-Arg.); Frontplate: Maple
FEATURES Arched sides for low note development; Extra wide dimensions; Dual internal fixed snare wires

3 EBONY BASS FOOT SWITCH CAJON

SIZE 13 1/4" W x 19 3/4" H x 13 1/2" D
MATERIALS Resonating body: Baltic Birch (*Betula pendula*); Frontplate: Ebony
FEATURES Foot activated snare switch; Extra wide body for deep bass

4 MAPLE BASS CAJON

SIZE 13 1/2" W x 19 1/4" H x 14" D
MATERIALS Resonating body: Eco-friendly medium density fiberboard; Frontplate: Maple
FEATURES Jumbo bass size for optimal low notes; Dual internal fixed sets of snare wires

5 VERTICAL SUBWOOFER CAJON

SIZE 15 1/2" W x 19 1/4" H x 11 3/4" D
MATERIALS Resonating body: Eco-friendly medium density fiberboard; Frontplate: Makah-Burl

FEATURES Vertical forward facing sound ports; Dual internal fixed snare wires and bass reflex channel; Responsive Makah-Burl frontplate; Enhanced bass notes

6 SUBWOOFER CAJONS

SIZES **SUBCAJ1AWA** 11 3/4" W x 19 3/4" H x 12 1/4" D
SUBCAJ5WN 13 1/2" W x 19 3/4" H x 13 3/4" D
MATERIALS Resonating body: Eco-friendly medium density fiberboard
SUBCAJ1AWA Frontplate: American White Ash (*Fraxinus Americana* L.)
SUBCAJ5WN Frontplate: Walnut (*Juglans regia* L.)
FEATURES Super low frequency; Forward projecting sound port; Dual internal fixed snare wires; Adjustable top corners

HEADLINER® SERIES & MAKE YOUR OWN CAJONS

1 **ANTI-SLIP SITTING SURFACE**



Siam Oak
HCAJ1NT

ADJUSTABLE SIZZLE EFFECT



Stained American White Ash
HCAJ1AWA

ECO-FRIENDLY MEDIUM DENSITY FIBERBOARD

2



Maple
MCAJ100BK-MA



3 **ALL NEEDED TOOLS INCLUDED**



Burl Wood
DMYO-CAJ-BU

DELUXE MODEL FEATURES LARGER SIZE

4



Baltic Birch
MYO-CAJ

5



Baltic Birch
MYO-BCAJ

6



MYO-TOOLS

ASSEMBLY INSTRUCTION COMES IN DIFFERENT LANGUAGES



Ovangkol
MYO-CAJ-OV

1 HEADLINER® SERIES STRING CAJONS

SIZE 11 3/4" W x 18" H x 12 1/4" D

MATERIALS **HCAJ1AWA**

Resonating body: Eco-friendly medium density fiberboard
Frontplate: Stained American White Ash (*Fraxinus Americana* L.)

HCAJ1NT

Resonating body: Siam Oak (*Hevea brasiliensis* Muell.-Arg.)

Frontplate: Siam Oak (*Hevea brasiliensis* Muell.-Arg.)

FEATURES Adjustable top corners; Adjustable sizzle effect; Anti-slip sitting surface; Wide sound options

INCLUDES Hex key

FINISH Matte

MATERIALS Resonating body: Eco-friendly medium density fiberboard

Frontplate: Maple

FEATURES Dual internal fixed snare wires; Adjustable top corner; Wide sound options

FINISH Matte

MAKE YOUR OWN 3 4 5

CONTAINS All of the materials and assembly instructions for completing the cajon

3 DELUXE MAKE YOUR OWN CAJON

SIZE 12" W x 19 1/4" H x 12" D

MATERIALS Resonating body: Baltic Birch (*Betula pendula*)

Frontplate: Burl Wood

INCLUDES All of the tools for completing the cajon

MATERIALS Resonating body: Baltic Birch (*Betula pendula*)

MYO-CAJ

Frontplate: Baltic Birch (*Betula pendula*)

MYO-CAJ-OV

Frontplate: Ovangkol (*Guibourtia ehie*)

Steel snare wires

COLOUR Natural

5 MAKE YOUR OWN BONGO CAJON

SIZE 15 3/4" W x 6 3/4" H x 7 1/4" D

MATERIAL Baltic Birch (*Betula pendula*)

COLOUR Natural

6 MAKE YOUR OWN CAJON TOOL BOX

CONTAINS 1 x screwdriver; 1 x wood glue; 2 x tension straps; 2 x sanding pads (coarse and fine)

FEATURE One-stop shop for all necessary tools to complete the MEINL Make Your Own Cajons and Bongo Cajon

2 HEADLINER® SERIES SNARE CAJON

SIZE 11 3/4" W x 18" H x 11 3/4" D

4 MAKE YOUR OWN CAJONS

SIZE 11 3/4" W x 18" H x 11 3/4" D

CAJON PEDALS



1

EASILY PLAY DOUBLE BASS PATTERNS ON YOUR CAJON



TMDCP

2

SPECIALLY POSITIONED CURVED STEEL BAR WITH DIRECT DRIVE



TMSTCP

3

ADJUSTABLE SPRING TENSION ON BOTH THE PEDAL AND THE MOUNT



TMCP

4

CAN BE PLAYED WITH YOUR HEEL OR TOES

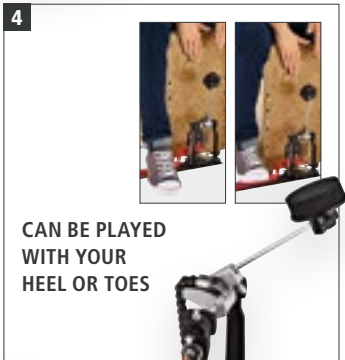

TMSTCP-2

BASSBOX/ SNAREBOX PEDAL (SEE PAGE 21)



TMBP

5

FOR PRONOUNCED KICK SOUND

Foam rubber



CPB1

6

ADJUSTABLE BRASS JINGLES



Soft foam

CPB2

7

DELIVERS HEAVY, FULL STROKES



Polymer bristles

CPB3

8

FOR DEEP AND PUNCHY NOTES



Soft foam

CPB4

9

GREAT FOR LOW VOLUME SETTINGS



Artificial fur

CPB5

1 DOUBLE BASS DIRECT DRIVE CAJON PEDAL

MATERIAL Steel

FEATURES Easily play double bass patterns on your cajon; Two pedals connected into one unit; Direct drive system provides a smooth, responsive feel; Adjustable spring tension; Cradle-like mount fits any common cajon and keeps the pedals secure

INCLUDES Drum key

2 DIRECT DRIVE CAJON PEDAL

MATERIAL Steel

FEATURES Cradle-like mount fits all common cajons; Adjustable spring tension; Natural foot position for ease of use

3 CAJON PEDAL

MATERIALS Steel; Plastic

FEATURES Cradle-like mount fits all common cajons; Ultra-smooth and durable cable; Position anywhere for optimal playability

INCLUDES Drum key; Soft foam beater

4 DIRECT DRIVE HEEL ACTIVATED CAJON PEDAL

MATERIAL Steel

FEATURES Simple design for steady bass drum rhythms; Cradle-like mount fits most cajons

INCLUDES Drum key

5 HAMMER HEAD CAJON & BASS DRUM BEATER

MATERIAL Foam rubber

FEATURES Soft foam rubber draws a deep bass sound from cajons; Dual playing surfaces for a variety of boom and punch

6 JINGLE CONTACT CAJON & BASS DRUM BEATER

MATERIALS Soft foam rubber; Brass jingles

FEATURES Easily turn the jingles on or off as desired throughout your set

7 BRUSH CAJON & BASS DRUM BEATER

MATERIAL Rippled polymer bristles

FEATURES Extra thick set of wavy polymer bristles; Two adjustable control rings; Warm, slightly mellow attack

8 STANDARD CAJON & BASS DRUM BEATER

MATERIAL Soft foam rubber

9 WOLLY MAMMOTH CAJON BEATER

MATERIALS Artificial fur; Soft foam

CAJON DRUM SET STANDS & CAJON TAPS

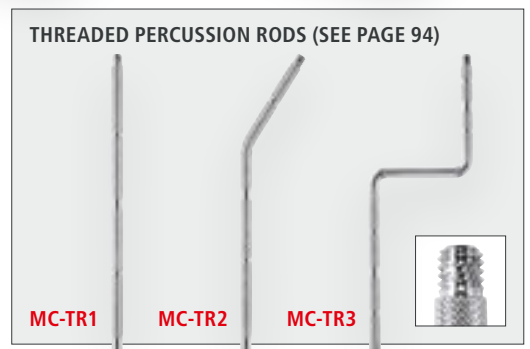
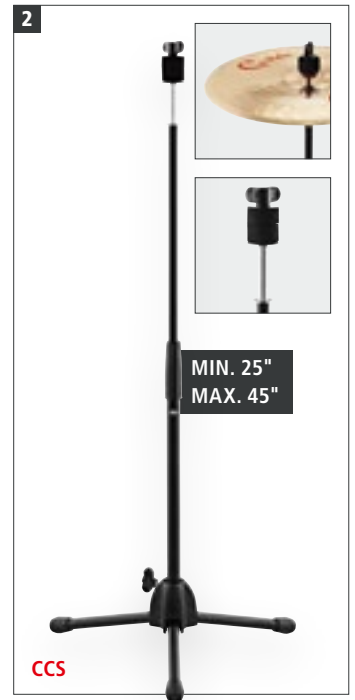
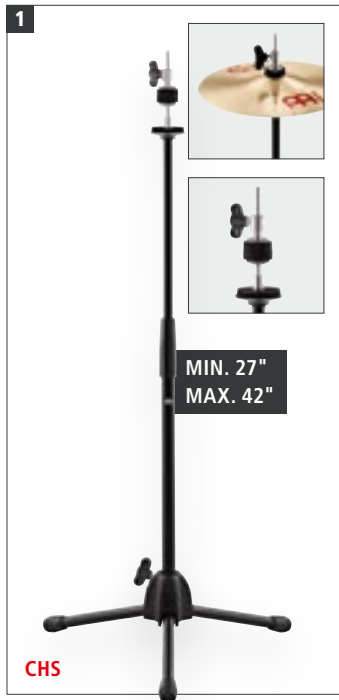

CAJON DRUM SET STANDS 1 2 3

MATERIAL Black powder coated aluminum
FEATURE Foldable legs, height adjustable

1 CAJON HIHAT STAND

FEATURES Standard hihat clutch and padded seat
Fixed internal rod for closed hihat sound

2 CAJON CYMBAL STAND

FEATURES Standard cymbal stand top
Use with any cymbal type

3 CAJON ADD-ON STAND

FEATURES 3/8" threaded connector top
Perfect for the MEINL Cajon Taps or Mountable Cajon Snare

CAJON TAPS 4 5 6

SIZE 5 3/4"
MATERIAL Siam Oak (*Hevea brasiliensis* Muell.-Arg.)
FEATURES Threaded 3/8" connection underneath
Mountable on the MEINL Cajon Add-On Stand
FINISH Black

4 CAJON JINGLE TAP

FEATURE Stainless steel jingles for bright accents

5 CAJON SNARE TAP

FEATURE Internal snares for high pitched snare cajon sound

6 CAJON TOM TAP

FEATURE Hollow inside for a high pitched "tom" sound

7 MOUNTABLE CAJON SNARE WITH THREADED 3/8" CONNECTION

SIZE 7 1/2"
MATERIAL Siam Oak (*Hevea brasiliensis* Muell.-Arg.)
FEATURES Internal Snare Wires
Threaded 3/8" connection to mount on the MEINL Cajon Add-On Stand
Great auxiliary snare option for cajon players who want to expand their grooves
INCLUDES Silicone Protection Cover
COLOUR BK: Black

CAJON DRUM SETS

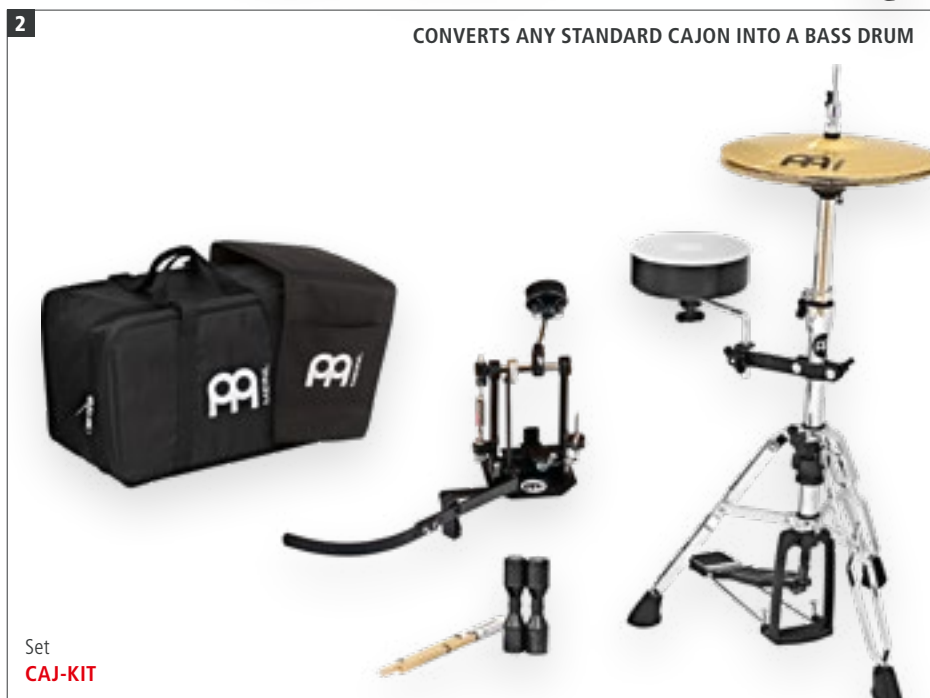
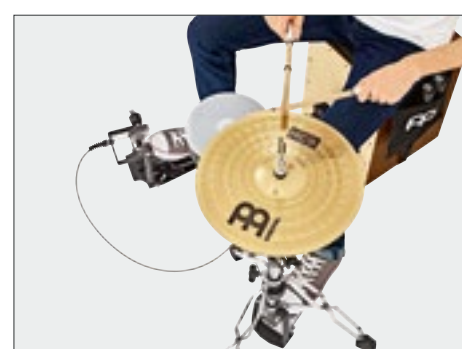
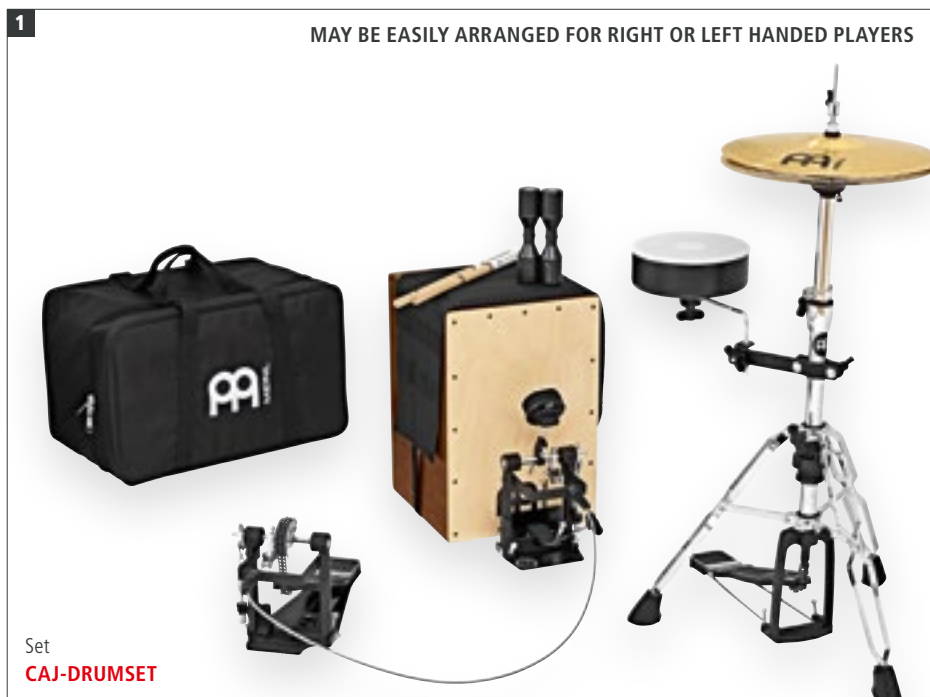

1 CAJON DRUM SET

CONTAINS Birch wood cajon without snares for enhanced bass
Cajon Pedal
Mountable Cajon Snare including silicone protection cover
Multi-Clamp
HCS 13" hihat cymbal pair with Low Hat
Bamboo Flex Multi-Rods for Cajon
Cajon Blanket with pockets for accessories
Luis Conte Live Shaker
Cajon Gig Bag

FEATURES May be easily arranged for right or left handed players
This set includes everything needed for players looking to perform their normal drum set rhythms in smaller, intimate acoustic settings
The elements of this set give you the same feeling as sitting down at a drum kit

2 CAJON DRUM SET CONVERSION KIT

CONTAINS Direct Drive Cajon Pedal
Mountable Cajon Snare including silicone protection cover
Multi-Clamp
HCS 13" hihat cymbal pair with Low Hat
Bamboo Flex Multi-Rods for Cajon
Cajon Blanket with pockets for accessories
Luis Conte Live Shaker
Cajon Gig Bag

FEATURES Converts any standard cajon into a bass drum (cajon not included)
Expand your cajon into a small, reduced volume drum set
Low-key stage footprint
Perfect for acoustic shows, jam sessions, or street performances

3 MOUNTABLE CAJON SNARE

SIZE 7 1/2"

MATERIAL Siam Oak (*Hevea brasiliensis* Muell.-Arg.)

FEATURES Internal Snare Wires
Standard 3/8" rod mounting bracket
L-shaped rod with knurled surface

INCLUDES

COLOUR **BK:** Black

4 SILICONE PROTECTION COVER

SIZE 7 1/2"

MATERIAL Silicone

FEATURES Shields your snare cajon from stick marks or scratches; Removable at any time

CAJON ADD-ONS

ADD NEW SOUNDS
TO YOUR CAJON



1



WC1-M

2

STAINLESS STEEL JINGLES



WJC1-M

3

STAINLESS STEEL JINGLES



JT-S-BK

4

EXTRA POCKET FOR
SMALL PERCUSSION



CAJ-BLK

5

INTERNAL SNARE EFFECT



WSS1BK

6

DESIGNED TO HOLD OUR
CAJON ADD-ONS CLOSE
TO THE PLAYING SURFACE



Medium
CSM-M

Large
CSM-L

1 CAJON CASTANET

SIZE M: Medium
MATERIAL Siam Oak (*Hevea brasiliensis* Muell.-Arg.)
FEATURES Spring-opened; Hook and loop fastener goes on any surface
COLOUR Black
FINISH Matte

2 CAJON JINGLE CASTANET

SIZE M: Medium
MATERIAL Siam Oak (*Hevea brasiliensis* Muell.-Arg.)
FEATURES Spring-opened; Hook and loop fastener goes on any surface; Stainless steel jingles
COLOUR Black
FINISH Matte

3 JINGLE TAP

SIZE Medium
MATERIAL Siam Oak (*Hevea brasiliensis* Muell.-Arg.)
FEATURES Stainless steel jingles; Hook and loop fastener goes on any surface
COLOUR BK: Black

4 CAJON BLANKET

MATERIAL Heavy-duty nylon
FEATURES Fits on any cajon; Hook and loop fastener to mount additional add-ons
COLOUR Black

5 WOOD SIDE SNARE

MATERIAL Siam Oak (*Hevea brasiliensis* Muell.-Arg.)
FEATURES Internal snare effect; Hook and loop fastener attaches to Cajon body; Ergonomic shape; Unobtrusive low profile
COLOUR BK: Black
FINISH Matte

6 CAJON SIDE MOUNTS

SIZES M: Medium
L: Large
MATERIAL Siam Oak (*Hevea brasiliensis* Muell.-Arg.)
FEATURES Easy handling; Hook and loop fastener goes on any surface; Offers better cajon accessory placement
COLOUR Black

7 KNEE PAD JINGLE TAP & KNEE PAD SNARE TAP

MATERIAL Siam Oak (*Hevea brasiliensis* Muell.-Arg.)
FEATURES Strap with hook and loop fastener to mount on your leg
KP-JT-BK: Stainless steel jingles
KP-ST-BK: Snare effect
COLOUR BK: Black



8 MOTION SHAKERS

MATERIAL Plastic
FEATURES Comfortable to wear on your fingers
MS-BK: Cutting shaker sound
MS-GR: Crisp sound with more volume
COLOURS **BK:** Black
GR: Grey

9 CAJON RING CASTANETS

SIZE Large
MATERIALS **CRC1BK:** Siam Oak (*Hevea brasiliensis* Muell.-Arg.)
PCRC1BK: Plastic
COLOUR **BK:** Black

10 FINGER JINGLES

MATERIALS Siam Oak (*Hevea brasiliensis* Muell.-Arg.)
FJS1A: Aluminum jingles
FJS1S: Stainless steel jingles

11 CAJON SPINNER

SIZE 13 3/4" W x 1 1/2" H x 13 3/4" D
MATERIAL Baltic Birch (*Betula pendula*)
FEATURES Durable turntable; Easy rotatable; Fits any common cajon
COLOUR Black
FINISH Matte

12 SYNTHETIC LEATHER CAJON SEATS

MATERIAL Sleek faux leather
FEATURES Sleek faux leather cajon seat lets you play in comfort and style; The cushion provides lower body support for long sets on a cajon; Fits all common cajons
FINISHES **GR:** Grey
VBR: Vintage Brown
VR: Vintage Red

13 DELUXE CAJON SEAT

SIZE 9 3/4" x 9 1/2"
MATERIALS Inner material foam
 Outer material leatherette
FEATURES Thick padding with black leather finish; Embroidered with sleek red stitching and topped with a stamped MEINL logo; Elegant design and ultra-comfortable feel

14 CAJON PAD

SIZE 10" x 10"
MATERIAL Soft foam

15 CAJON PERC PACK

CONTAINS Cajon Pad; Compact Foot Tambourine; Motion Shaker; Cajon Castanet, large; Luis Conte Live Shaker

FOOT PERCUSSION

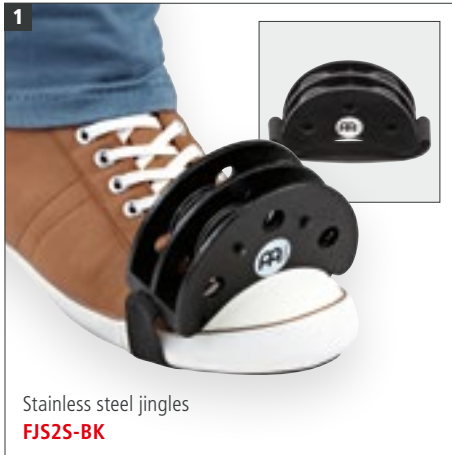

Stainless steel jingles
FJS2S-BK



Stainless steel jingles
CFJS2S-BK



Stainless steel jingles
CFT5-BK



Black
FS-BK



Black
CFC-BK



Natural
FR1NT



Stainless steel jingles
HTA

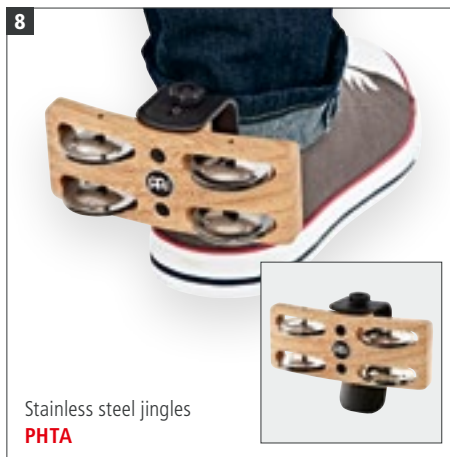

Stainless steel jingles
PHTA



Black
HSH

1 FOOT TAMBOURINE

MATERIALS Siam Oak (*Hevea brasiliensis* Muell.-Arg.); Stainless steel jingles
FEATURE Hassle-free mounting

2 COMPACT FOOT TAMBOURINE

MATERIALS Plastic; Stainless steel jingles
FEATURE Attaches quickly and easily to foot via elastic strap

3 CAJON FOOT TAMBOURINE

MATERIALS Siam Oak (*Hevea brasiliensis* Muell.-Arg.); Stainless steel jingles
FEATURES 5 pairs of stainless steel jingles; Easily mountable

4 FOOT SHAKER

MATERIAL Plastic
FEATURES Easy mountable; Shaker mounted at a special angle for precise control

5 CAJON FOOT CASTANET

MATERIALS Siam Oak (*Hevea brasiliensis* Muell.-Arg.); Plastic
FEATURES Traditional castanet sound; Easily mountable; Pair of plastic castanets

6 FOOT RATTLE

MATERIAL Siam Oak (*Hevea brasiliensis* Muell.-Arg.)
FEATURE Hook and loop fastener

7 HEEL TAMBOURINE

MATERIALS Siam Oak (*Hevea brasiliensis* Muell.-Arg.); Plastic; Stainless steel jingles
FEATURES Stainless steel jingles for a bright full sound; Shoehorn design fits comfortably against your heel; Great accessory for hands free playing

8 PROFESSIONAL HEEL TAMBOURINE

MATERIALS Siam Oak (*Hevea brasiliensis* Muell.-Arg.); Plastic; Stainless steel jingles
FEATURES Stainless steel jingles for a bright, full sound; Adjustable mounting system fits perfectly against your heel; Great accessory for hands-free playing

9 HEEL SHAKER

MATERIAL Plastic
FEATURES Great accessory for hands-free playing; Shoehorn design fits comfortably against your heel

BASSBOX & SNAREBOX 10 11

FEATURES Perfect for guitarists and singers; Aluminum rail to mount any common foot pedal
COLOUR Black
FINISH Matte

BASSBOX, SNAREBOX & FOOT CABASA



FOOT PERCUSSION

10 ALUMINUM RAIL TO MOUNT ANY COMMON FOOT PEDAL



Baltic Birch
BASSBOX

L-SHAPED SOFT FOAM BEATER INCLUDED

11 TWO INTERNAL SNARE WIRES



Baltic Birch
SNAREBOX

L-SHAPED FELT BEATER INCLUDED

12



Soft foam
BBB2

13



Felt
SBB1

14



Brass jingles
BBB1

15 NEW



Foam rubber
BBB3

16 NEW



Artificial fur
BBB4



17



PERFECT FOR THE MEINL BASSBOX AND SNAREBOX

TMBP

18



Additional springs with more tension
SPARE-20

FCA5-L

19 NEW



Set
MPTHS

USE YOUR FOOT TO EASILY TAP ON THE TAMBOURINE



10 BASSBOX

SIZE 17 1/2" W x 6 3/4" H x 11 3/4" D
MATERIAL Resonating body: Baltic Birch (*Betula pendula*)
FEATURE Immense bass sound
INCLUDES L-shaped soft foam beater

11 SNAREBOX

SIZE 7 1/2" W x 7 1/2" H x 13" D
MATERIAL Baltic Birch (*Betula pendula*)
FEATURE Dual internal fixed snare wires
INCLUDES L-shaped felt beater

12 BASSBOX BEATER

MATERIAL Soft foam rubber
FEATURE Punchy response

13 SNAREBOX BEATER

MATERIAL Felt
FEATURE Crisp snare response

14 JINGLE CONTACT BASSBOX/SNAREBOX BEATER

MATERIALS Soft foam rubber; Brass jingles
FEATURE Soft L-shaped foam rubber beater with adjustable brass jingles

15 HAMMER HEAD BASSBOX/SNAREBOX BEATER

MATERIAL Foam rubber
FEATURES Hammer Head shape for a pronounced kick sound; Dual playing surfaces for boom or punch; Draws out a naturally deep tone

16 WOOLLY MAMMOTH BASSBOX/SNAREBOX BEATER

MATERIAL Artificial fur; Soft foam
FEATURES Woolly Mammoth beater produces a soft kick sound; Delivers a mellow attack for low volume and texture

17 BASSBOX/SNAREBOX PEDAL

MATERIAL Steel
FEATURE Adjustable spring tension to dial in your comfort zone

18 FOOT CABASA (PATENTED)

SIZE Large
MATERIALS Steel chain and stainless steel cylinder; Wooden body; Black powder coated pedal
FEATURES Optional single or double-stroke setting; 5 sound ports on each side for more volume (CN, DE, US patent)
INCLUDES Drum key; Foot pedal

19 TAMBOURINE HOLDER SET

MATERIAL Baltic Birch (*Betula pendula*)
CONTAINS Tambourine Holder; Headliner® Series Hand Held ABS Tambourine (HTBK)
FEATURE Perfect for cajon players, guitarists and singers

JR. & ROPE TUNED TRAVEL SERIES DJEMBES

1



Blue, 7"
JRD-B

Green, 7"
JRD-G

Yellow, 7"
JRD-Y

Orange, 7"
JRD-O

Red, 7"
JRD-R

Silver, 7"
JRD-S

Black, 7"
JRD-BK

NEW



Twisted Amber, 7"
JRD-TA

Simbra, 7"
JRD-SI

Pharaoh's Script, 7"
JRD-PS

Kenyan Quilt, 7"
JRD-KQ

2



DAY OF THE DEAD

12"
PADJ7-L-F

10"
PADJ7-M-F

SYNTHETIC HEAD

3



PHANTOM BLACK

12"
PADJ4-L-G

10"
PADJ4-M-G

BLACK COLOURED HAND SELECTED GOATSKIN HEAD



KANGA SARONG

12"
PADJ6-L-F

10"
PADJ6-M-F

SYNTHETIC HEAD



SIMBRA

12"
PADJ5-L-F

10"
PADJ5-M-F

SYNTHETIC HEAD

1 JR. DJEMBES

SIZE 7" diameter, 12 1/2" tall
ROPE 14 runners
MATERIALS Synthetic shell; Synthetic head
FEATURES Grab-and-go for any occasion, indoors or outside; Compact size and lightweight shell; Pre-stretched ropes; Produces sharp slaps and deep bass tones; 100% synthetic head and shell are perfect for outdoor playing
COLOURS **B:** Blue
BK: Black
G: Green
O: Orange
R: Red
S: Silver
Y: Yellow
FINISHES **KQ:** Kenyan Quilt
PS: Pharaoh's Script
SI: Simbra
TA: Twisted Amber

2 ROPE TUNED TRAVEL SERIES DJEMBES, SYNTHETIC HEAD (PATENTED)

SIZES **M:** 10" diameter, 20" tall
L: 12" diameter, 24" tall
HTP ROPES **M:** 4 mm thickness, 25 runners
L: 4 mm thickness, 30 runners
MATERIALS Synthetic shell; Synthetic head
FEATURES 100% synthetic heads and shells are perfect for outdoor playing; Ultra light weight makes them easy to carry; Pre-stretched HTP nylon ropes; Produces sharp slaps and deep bass tones; Non-slip rubber bottom to protect the drum from scratches
FINISHES **PADJ5:** Simbra
PADJ6: Kanga Sarong
PADJ7: Day of the Dead

3 ROPE TUNED TRAVEL SERIES DJEMBES, GOATSKIN HEAD (PATENTED)

SIZES **M:** 10" diameter, 20" tall
L: 12" diameter, 24" tall
HTP ROPES **M:** 4 mm thickness, 25 runners
L: 4 mm thickness, 30 runners
MATERIALS Synthetic shell; Black coloured hand selected goatskin head
FEATURES Goatskin heads give you authentic sound and feel; Synthetic shells are perfect for outdoor playing; Ultra light weight makes them easy to carry; Pre-stretched HTP nylon ropes; Produces sharp slaps and deep bass tones; Non-slip rubber bottom to protect the drum from scratches
FINISH **PADJ4:** Phantom Black



4 ROPE TUNED TRAVEL SERIES DJEMBES, SYNTHETIC HEAD (PATENTED)

SIZES **S:** 8" diameter, 16" tall
M: 10" diameter, 20" tall
L: 12" diameter, 24" tall
XL: 14" diameter, 26" tall

HTP ROPES **S:** 4 mm thickness, 20 runners
M: 4 mm thickness, 25 runners
L: 4 mm thickness, 30 runners
XL: 5 mm thickness, 35 runners

MATERIALS Synthetic shell; Synthetic head

FEATURES 100% synthetic heads and shells are perfect for outdoor playing; Ultra light weight makes them easy to carry; Pre-stretched HTP nylon ropes; Produces sharp slaps and deep bass tones; Non-slip rubber bottom to protect the drum from scratches

FINISHES **PADJ1:** Pharaoh's Script
PADJ2: Kenyan Quilt

5 ROPE TUNED TRAVEL SERIES DJEMBES, GOATSKIN HEAD (PATENTED)

SIZES **S:** 8" diameter, 16" tall
M: 10" diameter, 20" tall
L: 12" diameter, 24" tall
XL: 14" diameter, 26" tall

HTP ROPES **S:** 4 mm thickness, 20 runners
M: 4 mm thickness, 25 runners
L: 4 mm thickness, 30 runners
XL: 5 mm thickness, 35 runners

MATERIALS Synthetic shell; Hand selected goatskin head

FEATURES Goatskin heads give you authentic sound and feel; Synthetic shells are perfect for outdoor playing; Ultra light weight makes them easy to carry; Pre-stretched HTP nylon ropes; Produces sharp slaps and deep bass tones; Non-slip rubber bottom to protect the drum from scratches

FINISHES **PADJ1:** Pharaoh's Script
PADJ2: Kenyan Quilt

MECHANICAL TUNED TRAVEL SERIES DJEMBES



1 MECHANICAL TUNED TRAVEL SERIES DJEMBES, SYNTHETIC HEAD (PATENTED)

- SIZES** **S:** 8" diameter, 16" tall
M: 10" diameter, 20" tall
L: 12" diameter, 24" tall
XL: 14" diameter, 26" tall
- MATERIALS** Synthetic shell
Synthetic head
- FEATURES** 100% synthetic heads and shells are perfect for outdoor playing
Ultra light weight makes them easy to carry
Quick and easy mechanical tuning system
Produces sharp slaps and deep bass tones
Non-slip rubber bottom to protect the drum from scratches
- FINISHES** **PMDJ1:** Pharaoh's Script
PMDJ2: Kenyan Quilt

2 MECHANICAL TUNED TRAVEL SERIES DJEMBES, GOATSKIN HEAD (PATENTED)

- SIZES** **S:** 8" diameter, 16" tall
M: 10" diameter, 20" tall
L: 12" diameter, 24" tall
XL: 14" diameter, 26" tall
- MATERIALS** Synthetic shell
Hand selected goatskin head
- FEATURES** Goatskin heads give you authentic sound and feel
Synthetic shells are perfect for outdoor playing
Ultra light weight makes them easy to carry
Quick and easy mechanical tuning system
Produces sharp slaps and deep bass tones
Non-slip rubber bottom to protect the drum from scratches
- FINISHES** **PMDJ1:** Pharaoh's Script
PMDJ2: Kenyan Quilt

ALPINE SERIES DJEMBES



3

NEW



12"
ADJ12-DA



10"
ADJ10-DA

DAY OF THE DEAD

NEW



12"
ADJ12-BW

SYNTHETIC HEAD



10"
ADJ10-BW

BARNWOOD

NEW



12"
ADJ12-KA



10"
ADJ10-KA

KANGA SARONG

NEW



12"
ADJ12-SI



10"
ADJ10-SI

SIMBRA

SYNTHETIC DJEMBES

3 ALPINE SERIES DJEMBES

SIZES ADJ10: 10" diameter, 20" tall
ADJ12: 12" diameter, 24" tall

MATERIALS Synthetic shell
Synthetic head

FEATURES Durable, synthetic head and shell
Ultra light weight
Mechanical tuning system
Perfect for travel and outdoor performance

FINISHES BW: Barnwood
DA: Day of the Dead
KA: Kanga Sarong
SI: Simbra



ROPE TUNED HEADLINER® SERIES WOOD DJEMBES



ROPE TUNED HEADLINER® SERIES WOOD DJEMBES 1 2 3 4

SIZES

- S:** 8" diameter, 15 3/4" tall
- M:** 10" diameter, 20" tall
- L:** 12" diameter, 24" tall
- XL:** 13" diameter, 25" tall

PP ROPES

- S:** 4 mm thickness, 16 runners
- M:** 4 mm thickness, 18 runners
- L:** 5 mm thickness, 20 runners
- XL:** 6 mm thickness, 24 runners

1 NILE SERIES

MATERIALS Mahogany Wood (*Swietenia macrophylla*)
Hand selected goatskin heads

FEATURES Carved from one solid piece of plantation grown Mahogany Wood
Pre-stretched PP nylon ropes
Hand carved shells

COLOUR Brown

2 BLACK RIVER SERIES

MATERIALS Mahogany Wood (*Swietenia macrophylla*)
Hand selected goatskin heads

FEATURES Carved from one solid piece of plantation grown Mahogany Wood
Pre-stretched PP nylon ropes
Hand carved shells

COLOUR Black

3 ARTIFACT SERIES

MATERIALS Mahogany Wood (*Swietenia macrophylla*)
Hand selected goatskin heads

FEATURES Carved from one solid piece of plantation grown Mahogany Wood
Pre-stretched PP nylon ropes
Hand carved shells

COLOUR Brown

4 CONGO SERIES

MATERIALS Mahogany Wood (*Swietenia macrophylla*)
Hand selected goatskin heads

FEATURES Carved from one solid piece of plantation grown Mahogany Wood
Pre-stretched PP nylon ropes
Hand carved shells
Ornamental carving

COLOUR Dark Brown

MINI & ROPE TUNED WOOD DJEMBES



1

Python Design, 4 1/2"
HDJ5-XXS

Dark Serpent Design, 4 1/2"
HDJ6-XXS

Gecko Design, 4 1/2"
HDJ7-XXS

Flower Design, 4 1/2"
HDJ8-XXS

2

BLACK COLOURED HAND SELECTED GOATSKIN HEADS

FIRE RHYTHM SERIES

13"
ADJ7-XL

12"
ADJ7-L

10"
ADJ7-M

EARTH RHYTHM SERIES

13", bundle with bag
ADJ3-XL+BAG

12", bundle with bag
ADJ3-L+BAG

10", bundle with bag
ADJ3-M+BAG

WATER RHYTHM SERIES

13", bundle with bag
ADJ2-XL+BAG

12", bundle with bag
ADJ2-L+BAG

10", bundle with bag
ADJ2-M+BAG

WOOD DJEMBES

1 AFRICAN STYLE MINI DJEMBES

SIZE 4 1/2" (4 1/4" - 4 3/4") diameter, 8" tall
PP ROPE 3 mm thickness, 10 runners
MATERIALS Mahogany Wood (*Swietenia macrophylla*)
 Hand selected goatskin head
FEATURES Carved from one solid piece of plantation grown Mahogany Wood
 High quality PP nylon rope
 Hand painted shell
FINISHES **HDJ5:** Python Design
HDJ6: Dark Serpent Design
HDJ7: Gecko Design
HDJ8: Flower Design

2 ORIGINAL AFRICAN STYLE ROPE TUNED WOOD DJEMBES

SIZES **M:** 10" (9 1/4" - 10 1/4") diameter, 20" tall
L: 12" (10 3/4" - 12 1/4") diameter, 24" tall
XL: 13" (12 3/4" - 13 3/4") diameter, 25" tall
HTP ROPES **M:** 4 mm thickness, 25 runners
L: 4 mm thickness, 35 runners
XL: 5 mm thickness, 35 runners
MATERIALS Mahogany Wood (*Swietenia macrophylla*)
 Hand selected goatskin heads
FEATURES Carved from one solid piece of plantation grown Mahogany Wood
 Pre-stretched HTP nylon ropes
 Hand carved shells
 Ornamental carving
ADJ7
 Black coloured hand selected goatskin heads
 Coloured rope wrapping

INCLUDES **ADJ2, ADJ3**
 Professional Djembe Bag made out of heavy-duty padded nylon

COLOURS **ADJ2:** Brown
ADJ3: Brown/Black
ADJ7: Black

PROFESSIONAL, TONGO CARVED & ARTISAN DJEMBES

1 SPECIAL "AFRICAN QUEEN" CARVING



12" **PROADJ4-L**

10" **PROADJ4-M**



1 SPECIAL "VILLAGE" CARVING



12" **PROADJ2-L**

10" **PROADJ2-M**

2 DELUXE CARVING

14" **PROADJ3-XXL**

3 COLOURED ROPE WRAPPING



12" **AE-DJTC1-L**

3 COLOURED ORNAMENTAL CARVING



12" **AE-DJTC2-L**

4



KES-01



1 PROFESSIONAL AFRICAN STYLE DJEMBES

SIZES **M:** 10" (9 1/4" - 10 1/4") diameter, 20" tall
L: 12" (10 3/4" - 12 1/4") diameter, 24" tall

HTP ROPES **M:** 4 mm thickness, 25 runners
L: 4 mm thickness, 35 runners

MATERIALS Mahogany Wood (*Swietenia macrophylla*)
 Hand selected goatskin heads

FEATURES Carved from one solid piece of plantation grown Mahogany Wood;
 Pre-stretched HTP nylon ropes

PROADJ2: "Village" carving
PROADJ4: "African Queen" carving

COLOUR Brown

2 ARTISAN EDITION DJEMBE

SIZE 14" (13 3/4" - 15 1/4") diameter, 26" tall

HTP ROPE 5 mm thickness, 40 runners

MATERIALS Mahogany Wood (*Swietenia macrophylla*)
 Hand selected goatskin head

FEATURES Carved from one solid piece of plantation grown Mahogany Wood; Pre-stretched HTP nylon rope; Deluxe carving

COLOUR Brown

3 ARTISAN EDITION TONGO CARVED DJEMBES

SIZE 12" (10 3/4" - 12 1/4") diameter, 24" tall

HTP ROPE 5 mm thickness, 30 runners

MATERIALS Mahogany Wood (*Swietenia macrophylla*)
 Hand selected goatskin heads

FEATURES Carved from one solid piece of plantation grown Mahogany Wood; Pre-stretched HTP nylon ropes; Hand carved shells

AE-DJTC1-L

Coloured rope wrapping;
 Ornamental carving

AE-DJTC2-L
 Coloured ornamental carving

COLOUR Brown

4 KESSING

SIZE Medium

MATERIAL Aluminum

FEATURES Provides a dry rattling accompaniment to the drum; Slides securely into the webbing and is removable

HEADLINER® & FLOATUNE SERIES WOOD DJEMBES



WOOD DJEMBES

1 ORIGINAL MEINL STYLE TUNING BRACKETS

Vintage Wine Barrel, 12 1/2"
HDJ500VWB-M

Natural, 12 1/2"
HDJ500NT

PROFESSIONAL DJEMBE STAND (SEE PAGE 88)

TMD

SAMBA BELT (SEE PAGE 62)

SB-R

2 FLOATUNE TUNING SYSTEM

Zebra Finished Ash, 12"
DJW3ZFA-M

3 FLOATUNE TUNING AVOIDS THE NEED TO DRILL THROUGH THE SHELL

Gold Amber Sunburst, 12"
DJW3GAB-M

Natural, 12"
DJW3NT

4 PROFESSIONAL SHOULDER STRAP

MDJS2

1 HEADLINER® SERIES WOOD DJEMBES
SIZE 12 1/2" diameter, 25 1/4" tall
MATERIALS Siam Oak (*Hevea brasiliensis* Muell.-Arg.)
 Hand selected goatskin head
FEATURES 8 mm strong tuning lugs
 2.6 mm rounded rims
 Original MEINL style tuning brackets
 Black powder coated hardware
 Sleek Hourglass shape for more comfort
INCLUDES Tuning key
COLOURS **NT:** Natural, high gloss
VWB-M: Vintage Wine Barrel, matte

Easy tuning and comfortable change of heads
 Rubber pads and lug placement offer perfect playing comfort
 Floatune Tuning System
 Chrome plated hardware
INCLUDES Accessory pouch
 L-shaped tuning key
 Tune Up Oil
COLOUR Zebra Finished Ash, matte

Rubber pads and lug placement offer perfect playing comfort
 Floatune Tuning System
 Chrome plated hardware
INCLUDES Accessory pouch
 L-shaped tuning key
 Tune Up Oil
COLOURS **GAB-M:** Gold Amber Sunburst, matte
NT: Natural, high gloss

2 FLOATUNE SERIES WOODCRAFT DJEMBE
SIZE 12" diameter, 24 1/4" tall
MATERIALS American White Ash (*Fraxinus americana* L.)
 True Skin Goat Head
FEATURES 8 mm strong tuning lugs
 3 mm rounded SSR-Rims

3 FLOATUNE SERIES WOOD DJEMBES
SIZE 12" diameter, 24 1/4" tall
MATERIALS Siam Oak (*Hevea brasiliensis* Muell.-Arg.)
 True Skin Goat Head
FEATURES 8 mm strong tuning lugs
 3 mm rounded SSR-Rims
 Easy tuning and comfortable change of heads

4 PROFESSIONAL SHOULDER STRAP
MATERIAL Heavy-duty nylon
FEATURES Holds any djembe or other drums in perfect playing position
 Length adjustable
 Adjustable shoulder padding
 Quick change hook
COLOUR Black

CONGA HEADS & MINI CONGAS

1



The REMO® Symmetry Conga Heads add more volume and resonance to your Conga. These are available for congas with this sign.



Black Calfskin Skydeep® **RHEAD-11BK** Black Calfskin Skydeep® **RHEAD-1134BK** Black Calfskin Skydeep® **RHEAD-1212BK**



Black Calfskin Skydeep® **RTHEAD-11BK** Black Calfskin Skydeep® **RTHEAD-1134BK** Black Calfskin Skydeep® **RTHEAD-1212BK**



Fiberskyn® **RHEAD-11NT** Fiberskyn® **RHEAD-1134NT** Fiberskyn® **RHEAD-1212NT**



Nuskyn® **RTHEAD-11NS** Nuskyn® **RTHEAD-1134NS** Nuskyn® **RTHEAD-1212NS**

2



Natural, 4 1/2" **MC100NT**

Wine Red, 4 1/2" **MC100WR**

Vintage Wine Barrel, 4 1/2" **MC100VWB**

3



CONGA-SAVER8 **CONGA-SAVER10**

4



COMES IN A SET OF 4

Set **MCR-BK**

5

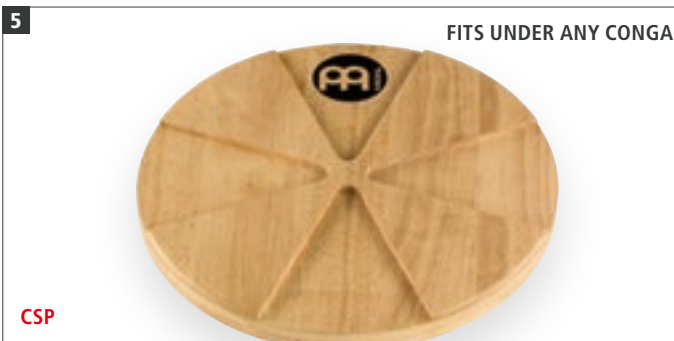

FITS UNDER ANY CONGA

CSP

1 REMO® SYMMETRY CONGA HEADS

SIZES **RHEAD-11:** 11" Quinto; SSR-Rim
RHEAD-1134: 11 3/4" Conga; SSR-Rim
RHEAD-1212: 12 1/2" Tumba; SSR-Rim
RTHEAD-11: 11" Quinto; TTR-Rim
RTHEAD-1134: 11 3/4" Conga; TTR-Rim
RTHEAD-1212: 12 1/2" Tumba; TTR-Rim
FIT FOR **RHEAD:** MCC, MEC, MP, FC, MSA, WKT, WCO, BWC
RTHEAD: LC
FINISHES **BK:** Black Calfskin Skydeep®
NS: Nuskyn®
NT: Fiberskyn®

FEATURES Contains every feature of a regular MEINL conga, at 2/5 the size
Tunable buffalo skin head with 4 chrome lugs and rounded rim
Great for spontaneous jam sessions or drum circles
COLOURS **NT:** Natural
VWB: Vintage Wine Barrel
WR: Wine Red

3 CONGA SAVERS

SIZES **CONGA-SAVER8:** for 8 mm tuning lugs
CONGA-SAVER10: for 10 mm tuning lugs
FEATURES Placed over the conga lugs to prevent them from damaging and scratching the shell
Conga remains fully tunable
PATENT MEINL Conga Saver (TH, US patent)

4 CONGA RISERS

MATERIAL Sturdy rubber
FEATURES Raise your drums off the floor to allow maximum sound projection
Provide a stable base on any surface
Come in a set of four
Flexible construction
COLOUR **BK:** Black

5 CONGA SOUND PLATE

SIZE 13 1/4"
MATERIAL Siam Oak (*Hevea brasiliensis* Muell.-Arg.)
FEATURE Provides a hard sound reflective surface under your conga

WOODCRAFT SERIES CONGAS



1



VINTAGE BLACK

VINTAGE BROWN



11"
WCO11VBK-M

11 3/4"
WCO1134VBK-M

12 1/2"
WCO1212VBK-M



11"
WCO11VBR-M

11 3/4"
WCO1134VBR-M

12 1/2"
WCO1212VBR-M

VINTAGE RED



11"
WCO11VR-M

11 3/4"
WCO1134VR-M

12 1/2"
WCO1212VR-M

2



EUROPEAN BIRCH



11"
BWC11

11 3/4"
BWC1134

12 1/2"
BWC1212

1 WOODCRAFT SERIES WCO CONGAS

SIZES **WCO11:** 11" Quinto, 30" tall
WCO1134: 11 3/4" Conga, 30" tall
WCO1212: 12 1/2" Tumba, 30" tall

MATERIALS Three ply American White Ash
(*Fraxinus americana* L.)

True Skin Buffalo Heads

FEATURES 10 mm strong tuning lugs
4 mm rounded SSR-Rims
Chrome plated hardware

INCLUDES MEINL Conga Saver (TH, US patent)

MEINL Conga Handle

MEINL Soundpads

Accessory pouch

L-shaped tuning key

Tune Up Oil

COLOURS **VBK-M:** Vintage Black

VBR-M: Vintage Brown

VR-M: Vintage Red

FINISH Matte

2 WOODCRAFT SERIES BWC CONGAS

SIZES **BWC11:** 11" Quinto, 30" tall
BWC1134: 11 3/4" Conga, 30" tall
BWC1212: 12 1/2" Tumba, 30" tall

MATERIALS European Birch (*Betula pendula*)

Hand selected Mule heads

FEATURES Natural finish European Birch shells
Focused sounds without obtrusive overtones

4 mm rounded SSR-Rims

Chrome plated hardware

INCLUDES MEINL Conga Saver (TH, US patent)

MEINL Conga Handle

MEINL Soundpads

Accessory pouch

L-shaped tuning key

Tune Up Oil

COLOUR Natural

FINISH High gloss



NENÉ VÁSQUEZ, GERMANY

CONGAS

WOODCRAFT TRADITIONAL, FLOATUNE SERIES CONGAS

1

ZEBRA FINISHED ASH



11"
WC11ZFA-M

11 3/4"
WC1134ZFA-M

12 1/2"
WC1212ZFA-M



DAVID MARCANO, PUERTO RICO

2

NATURAL



10"
FL10NT

11"
FL11NT

12"
FL12NT

13"
FL13NT

THE FLOATUNE TUNING SYSTEM
ALLOWS THE SHELL TO
VIBRATE FREELY



1 WOODCRAFT TRADITIONAL SERIES CONGAS

SIZES WC11: 11" Quinto, 30" tall
WC1134: 11 3/4" Conga, 30" tall
WC1212: 12 1/2" Tumba, 30" tall

MATERIALS Three ply American White Ash (*Fraxinus americana* L.)
True Skin Buffalo Heads

FEATURES 10 mm strong tuning lugs
5 mm traditional TTR-Rims
Chrome plated hardware

INCLUDES MEINL Conga Saver (TH, US patent)
MEINL Conga Handle
MEINL Soundpads
Accessory pouch
L-shaped tuning key
Tune Up Oil

COLOUR Zebra Finished Ash
FINISH Matte

2 FLOATUNE SERIES CONGAS

SIZES FL10: 10" Nino, 30" tall
FL11: 11" Quinto, 30" tall
FL12: 12" Conga, 30" tall
FL13: 13" Tumba, 30" tall

MATERIALS Two ply Siam Oak (*Hevea brasiliensis* Muell.-Arg.)
True Skin Buffalo Heads

FEATURES Floatune Tuning System
10 mm strong tuning lugs
4 mm rounded SSR-Rims
Chrome plated hardware

INCLUDES MEINL Conga Saver (TH, US patent)
MEINL Conga Handle
MEINL Soundpads
Accessory pouch
L-shaped tuning key
Tune Up Oil

COLOUR Natural
FINISH High gloss

PROFESSIONAL & FIBERCRAFT SERIES CONGAS



1 **REMO HEADS AVAILABLE**

NATURAL **BROWN BURL**

11" **MP11NT** 11 3/4" **MP1134NT** 12 1/2" **MP1212NT** 11" **MP11BB** 11 3/4" **MP1134BB** 12 1/2" **MP1212BB**

CONGAS

2 **REMO HEADS AVAILABLE**

TRUE SKIN BUFFALO HEADS **REMO® BLACK CALFSKIN SKYNDDEEP® HEADS**

11" **FC11BK** 11 3/4" **FC1134BK** 12 1/2" **FC1212BK** 11" **FCR11BK** 11 3/4" **FCR1134BK** 12 1/2" **FCR1212BK**

1 PROFESSIONAL SERIES CONGAS

- SIZES** **MP11:** 11" Quinto, 30" tall
MP1134: 11 3/4" Conga, 30" tall
MP1212: 12 1/2" Tumba, 30" tall
- MATERIALS** Two ply Siam Oak
(Hevea brasiliensis Muell.-Arg.)
 True Skin Buffalo Heads
- FEATURES** 10 mm strong tuning lugs
 4 mm rounded SSR-Rims
 Chrome plated hardware
- INCLUDES** MEINL Conga Saver (TH, US patent)
 MEINL Conga Handle
 MEINL Soundpads
 Accessory pouch
 L-shaped tuning key
 Tune Up Oil
- COLOURS** **BB:** Brown Burl
NT: Natural
- FINISH** High gloss

2 FIBERCRAFT SERIES CONGAS

- SIZES** **FC(R)11:** 11" Quinto, 30" tall
FC(R)1134: 11 3/4" Conga, 30" tall
FC(R)1212: 12 1/2" Tumba, 30" tall
- MATERIALS** Premium fiberglass
FC: True Skin Buffalo Heads
FCR: REMO® Black Calfskin Skynddeep® Heads (For more volume and resonance)
- FEATURES** 10 mm strong tuning lugs
 4 mm rounded SSR-Rims
 Chrome plated hardware
- INCLUDES** MEINL Conga Saver (TH, US patent)
 MEINL Conga Handle
 MEINL Soundpads
 Accessory pouch
 L-shaped tuning key
 Tune Up Oil
- COLOUR** **BK:** Black

REMO® SYMMETRY CONGA HEADS (SEE PAGE 30)



The REMO® Symmetry Conga Heads add more volume and resonance to your Conga. These are available for congas with this sign.





ARTIST SERIES CONGAS

1 **REMO HEADS AVAILABLE** **TRUE SKIN BUFFALO HEADS** *LCR* 



11" **LCR11NT-M** 11 3/4" **LCR1134NT-M** 12 1/2" **LCR1212NT-M**

REMO® NUSKYN® HEADS 



11" **LCR11NT-M** 11 3/4" **LCR1134NT-M** 12 1/2" **LCR1212NT-M**

2 **REMO HEADS AVAILABLE** **TRUE SKIN BUFFALO HEADS** *"MONGO" Santamaria* 



11" **MSA11AWA** 11 3/4" **MSA1134AWA** 12 1/2" **MSA1212AWA**



LUIS CONTE



"KACHIRO" THOMPSON



"MONGO" SANTAMARIA



DIEGO GALÉ

1 ARTIST SERIES CONGAS LUIS CONTE

SIZES **LC(R)11:** 11" Quinto, 30" tall
LC(R)1134: 11 3/4" Conga, 30" tall
LC(R)1212: 12 1/2" Tumba, 30" tall

MATERIALS Two ply Siam Oak
(Hevea brasiliensis Muell.-Arg.)
LC: True Skin Buffalo Heads
LCR: REMO® Nuskyn® Heads
 (For more volume and resonance)

FEATURES 8 mm strong tuning lugs
 5 mm traditional TTR-Rims
 Black powder coated hardware

INCLUDES MEINL Conga Saver (TH, US patent)
 MEINL Soundpads
 Accessory pouch
 L-shaped tuning key
 Tune Up Oil

COLOUR **NT:** Natural

FINISH Matte

2 ARTIST SERIES CONGAS

RAMON "MONGO" SANTAMARIA

SIZES **MSA11:** 11" Quinto, 30" tall
MSA1134: 11 3/4" Conga, 30" tall
MSA1212: 12 1/2" Tumba, 30" tall

MATERIALS Two ply American White Ash
(Fraxinus americana L.)
 True Skin Buffalo Heads

FEATURES 10 mm strong tuning lugs
 4 mm rounded SSR-Rims
 Gold tone hardware

INCLUDES MEINL Conga Saver (TH, US patent)
 MEINL Soundpads
 Accessory pouch
 L-shaped tuning key
 Tune Up Oil

COLOUR **AWA:** American White Ash

FINISH High gloss



3 **REMO HEADS AVAILABLE** **HAND SELECTED MULESKIN HEADS** *Kachiro Thompson*

11" **WKT11NT** 11 3/4" **WKT1134NT** 12 1/2" **WKT1212NT**

REMO® BLACK CALFSKIN SKYNDDEEP® HEADS

11" **WKTR11NT** 11 3/4" **WKTR1134NT** 12 1/2" **WKTR1212NT**

4 **REMO HEADS AVAILABLE** **NEW** **HAND SELECTED BUFFALO HEADS** *Diego Galé*

11" **DG11CW** 11 3/4" **DG1134CW** 12 1/2" **DG1212CW**

NEW **REMO® FIBERSKYN® HEADS**

11" **DGR11CW** 11 3/4" **DGR1134CW** 12 1/2" **DGR1212CW**

3 ARTIST SERIES CONGAS
WILLIAM "KACHIRO" THOMPSON
SIZES **WKT(R)11:** 11" Quinto, 30" tall
WKT(R)1134: 11 3/4" Conga, 30" tall
WKT(R)1212: 12 1/2" Tumba, 30" tall
MATERIALS Three ply Siam Oak
(Hevea brasiliensis Muell.-Arg.)
WKT: Hand selected muleskin heads
WKTR: REMO® Black Calfskin Skynddeep® Heads (For more volume and resonance)
FEATURES 10 mm strong tuning lugs
 4 mm rounded SSR-Rims
 Gold tone hardware
INCLUDES MEINL Conga Saver (TH, US patent)
 MEINL Conga Handle
 MEINL Soundpads
 Accessory pouch
 L-shaped tuning key; Tune Up Oil
COLOUR **NT:** Natural
FINISH High gloss

4 ARTIST SERIES CONGAS DIEGO GALÉ
SIZES **DG(R)11:** 11" Quinto, 30" tall
DG(R)1134: 11 3/4" Conga, 30" tall
DG(R)1212: 12 1/2" Tumba, 30" tall
MATERIALS Two ply Chamchuri Wood
DG: Hand selected buffalo heads
DGR: REMO® Fiberskyn® Heads (For more volume and resonance)
FEATURES 10 mm strong tuning lugs
 4 mm rounded SSR-Rims
 Brushed nickel hardware
INCLUDES MEINL Conga Saver (TH, US patent)
 MEINL Conga Handle
 MEINL Soundpads
 Accessory pouch
 L-shaped tuning key
 Tune Up Oil
COLOUR **CW:** Chamchuri Wood
FINISH High gloss

REMO® SYMMETRY CONGA HEADS
 (SEE PAGE 30)

REMO HEADS AVAILABLE

The REMO® Symmetry Conga Heads add more volume and resonance to your Conga. These are available for congas with this sign.

Fiberskyn®
 Nuskyn®
 Black Calfskin Skynddeep®

MARATHON® EXCLUSIVE & DESIGNER SERIES CONGAS



11"
MEC11NT-CH

11 3/4"
MEC1134NT-CH

12 1/2"
MEC1212NT-CH

11"
MECR11NT-CH

11 3/4"
MECR1134NT-CH

12 1/2"
MECR1212NT-CH

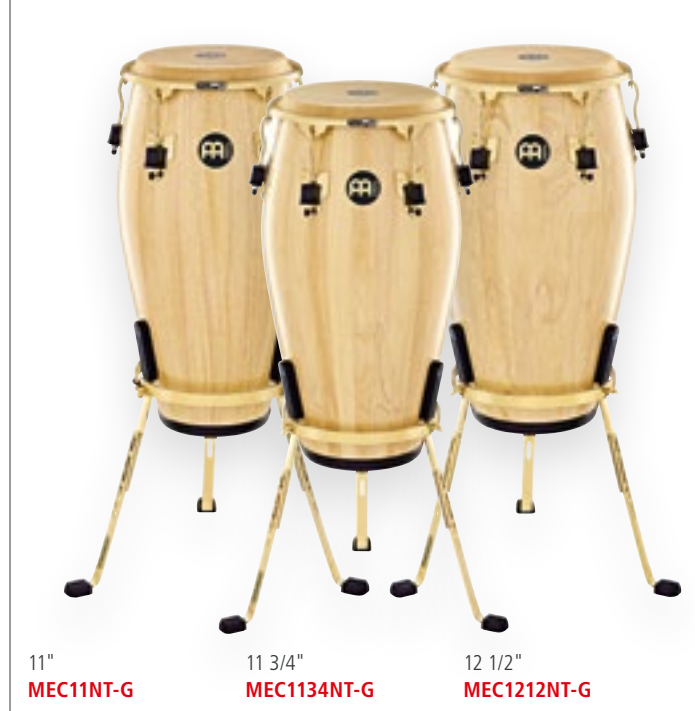

11"
MEC11NT-G

11 3/4"
MEC1134NT-G

12 1/2"
MEC1212NT-G



11"
MCC11LB

11 3/4"
MCC1134LB

12 1/2"
MCC1212LB

1 MARATHON® EXCLUSIVE SERIES CONGAS

SIZES **MEC(R)11:** 11" Quinto, 30" tall
MEC(R)1134: 11 3/4" Conga, 30" tall
MEC(R)1212: 12 1/2" Tumba, 30" tall

MATERIALS Two ply Siam Oak
(*Hevea brasiliensis* Muell.-Arg.)

MEC: True Skin Buffalo Heads

MECR: REMO® Fiberskyn® Heads
(For more volume and resonance)

FEATURES 8 mm strong tuning lugs
2.6 mm rounded SSR-Rims

CH: Chrome plated hardware

G: Gold tone hardware

INCLUDES Steely II Conga Stand (patented)
MEINL Conga Saver (TH, US patent)
MEINL Conga Handle
MEINL Sound Pads
Accessory pouch
L-shaped tuning key
Tune Up Oil

COLOUR **NT:** Natural
FINISH High gloss
PATENTS Steely-II patents:
L-shaped leg and metal spike attachment
(DE, TH, US patent)
U-shaped notch (US patent)
Ergonomic arched rubber bracing
(CN, DE, TH, US patent)
Notches for quick height adjustability
(DE patent)

2 MARATHON® DESIGNER SERIES CONGAS

SIZES **MCC11:** 11" Quinto, 30" tall
MCC1134: 11 3/4" Conga, 30" tall
MCC1212: 12 1/2" Tumba, 30" tall

MATERIALS Two ply Siam Oak
(*Hevea brasiliensis* Muell.-Arg.)
True Skin Buffalo Heads

FEATURES 8 mm strong tuning lugs
2.6 mm rounded SSR-Rims
Black powder coated hardware
INCLUDES Steely II Conga Stand (patented)
MEINL Conga Saver (TH, US patent)
Accessory pouch
L-shaped tuning key
Tune Up Oil

COLOUR **LB:** Leopard Burl
FINISH High gloss
PATENTS Steely-II patents:
L-shaped leg and metal spike attachment
(DE, TH, US patent)
U-shaped notch (US patent)
Ergonomic arched rubber bracing
(CN, DE, TH, US patent)
Notches for quick height adjustability
(DE patent)

MARATHON® CLASSIC SERIES CONGAS



3



NATURAL

11"
MCC11NT

11 3/4"
MCC1134NT

12 1/2"
MCC1212NT

ERGONOMIC ARCHED RUBBER BRACING

U-SHAPED NOTCH

NOTCHES FOR QUICK
HEIGHT ADJUSTABILITY

L-SHAPED LEG

METAL SPIKE ATTACHMENT

STEELY II CONGA STAND



CONGAS



SUPER NATURAL

11"
MCC11SNT-M

11 3/4"
MCC1134SNT-M

12 1/2"
MCC1212SNT-M



COFFEE BURST

11"
MCC11CB

11 3/4"
MCC1134CB

12 1/2"
MCC1212CB

3 MARATHON® CLASSIC SERIES CONGAS

SIZES **MCC11:** 11" Quinto, 30" tall
MCC1134: 11 3/4" Conga, 30" tall
MCC1212: 12 1/2" Tumba, 30" tall

MATERIALS Two ply Siam Oak
(*Hevea brasiliensis* Muell.-Arg.)
True Skin Buffalo Heads

FEATURES 8 mm strong tuning lugs
2.6 mm rounded SSR-Rims
Black powder coated hardware

INCLUDES Steely II Conga Stand (patented)
MEINL Conga Saver (TH, US patent)
Accessory pouch
L-shaped tuning key
Tune Up Oil

COLOURS **CB:** Coffee Burst, high gloss
NT: Natural, high gloss
SNT-M: Super Natural, matte

PATENTS

Steely-II patents:
L-shaped leg and metal spike attachment
(DE, TH, US patent)
U-shaped notch (US patent)
Ergonomic arched rubber bracing
(CN, DE, TH, US patent)
Notches for quick height adjustability
(DE patent)

REMO® SYMMETRY CONGA HEADS (SEE PAGE 30)



The REMO® Symmetry Conga Heads add more volume and resonance to your Conga. These are available for congas with this sign.

Fiberskyn®

Nuskyn®

Black Calfskin
Skyndee®



HEADLINER® & TRADITIONAL SERIES CONGAS



1 HEADLINER® SERIES CONGAS

SIZES **HC10:** 10" Nino, 28" tall
HC11: 11" Quinto, 28" tall
HC12: 12" Conga, 28" tall

MATERIALS Siam Oak (*Hevea brasiliensis* Muell.-Arg.)
 Hand selected buffalo heads

FEATURES 8 mm strong tuning lugs
 Original MEINL style tuning brackets
 2 mm rounded rims
 Black powder coated hardware

INCLUDES Height adjustable basket stands (patented) with quick set up system
 Tuning key

COLOURS **PBK-M:** Phantom Black
SNT-M: Super Natural
VWB-M: Vintage Wine Barrel

FINISH Matte

PATENTS Basket stand patents:
 Ergo arched rubber bracing (CN, DE, TH, US patent)
 U-shaped notch (US patent)
 L-shaped leg (DE patent)

2 HEADLINER® TRADITIONAL SERIES CONGAS

SIZES **HTC10:** 10" Nino, 28" tall
HTC11: 11" Quinto, 28" tall
HTC12: 12" Conga, 28" tall

MATERIALS Siam Oak (*Hevea brasiliensis* Muell.-Arg.)
 Hand selected buffalo heads

FEATURES 8 mm strong tuning lugs
 Original MEINL style tuning brackets
 5 mm traditional TTR-Rims
 Black powder coated hardware

INCLUDES Height adjustable basket stands (patented) with quick set up system
 Tuning key

COLOUR **WB-M:** Walnut Brown

FINISH Matte

PATENTS Basket stand patents:
 Ergo arched rubber bracing (CN, DE, TH, US patent)
 U-shaped notch (US patent)
 L-shaped leg (DE patent)

HEADLINER® SERIES CONGA SETS



3



Set, 10" & 11"
HC555NT



Set, 11" & 12"
HC512NT

NATURAL



Set, 10" & 11"
HC555VSB

VINTAGE SUNBURST



Set, 10" & 11"
HC888NT

THE BONGO MOUNT IS EASY MOUNTABLE ON OUR CONGA DOUBLE STANDS (SEE PAGE 86)



THBM



Set, 11" & 12"
HC512VSB



Set, 11" & 12"
HC812NT



Set, 10" & 11"
HC888VSB



Set, 11" & 12"
HC812VSB

3 HEADLINER® SERIES CONGA SETS

- SIZES** **HC555, HC888:** 10" Nino & 11" Quinto, 28" tall
HC512, HC812: 11" Quinto & 12" Conga, 28" tall
- MATERIALS** Siam Oak (*Hevea brasiliensis* Muell.-Arg.)
Hand selected buffalo heads
- FEATURES** 8 mm strong tuning lugs
Original MEINL style tuning brackets
2 mm rounded rims
Black powder coated hardware
- INCLUDES** Tuning key
HC555, HC512: Height adjustable basket stands (patented) with quick set up system
HC888, HC812: Height adjustable double braced tripod stand
- COLOURS** **NT:** Natural
VSB: Vintage Sunburst
- FINISH** High gloss

- PATENTS** Basket stand patents:
Ergo arched rubber bracing (CN, DE, TH, US patent)
U-shaped notch (US patent)
L-shaped leg (DE patent)



KEITA OGAWA, USA

CONGAS

BONGO HEADS & ARTIST, WOODCRAFT, COLLECTION,

1



The REMO® R-Series Bongo Heads add more volume and resonance to your Bongo. These are available for bongos with this sign.



Fiberskyn®
RHEAD-7NT



Fiberskyn®
RHEAD-812NT



Nuskyn®
RHEAD-7NS



Nuskyn®
RHEAD-812NS



Black Calfskin Skyndeeep®
RHEAD-7BK



Black Calfskin Skyndeeep®
RHEAD-812BK



2



NEW

TRUE SKIN CALF HEADS



Chamchuri Wood, 7" & 8 1/2"
DG400CW

NEW

REMO® FIBERSKYN® HEADS



Chamchuri Wood, 7" & 8 1/2"
DGR400CW

Diego Galé

3



Vintage Black, 7" & 8 1/2"
WB400VBK-M



Vintage Brown, 7" & 8 1/2"
WB400VBR-M



Vintage Red, 7" & 8 1/2"
WB400VR-M

1 REMO® R-SERIES BONGO HEADS

- SIZES** **RHEAD-7:** 7" Macho
RHEAD-812: 8 1/2" Hembra
- FIT FOR** LC300, FFB400, FWB400, CS400, WB400, BWB400
- FINISHES** **BK:** Black Calfskin Skyndeeep®
NS: Nuskyn®
NT: Fiberskyn®

2 ARTIST SERIES WOOD BONGO DIEGO GALÉ

- SIZES** 7" Macho & 8 1/2" Hembra
- MATERIALS** Chamchuri Wood
DG400CW: Hand selected calf heads
DGR400CW: REMO® Fiberskyn® Heads (For more volume and resonance)
- FEATURES** MEINL Free Ride Suspension System
Brushed nickel hardware
8 mm strong tuning lugs
3 mm rounded SSR-Rims
Resonance Shaping Area

COLOUR Natural, high gloss

WOODCRAFT SERIES WOOD BONGOS

- 3 4 5**
- FEATURES** MEINL Free Ride Suspension System
Chrome plated hardware
Resonance Shaping Area
- INCLUDES** Accessory pouch; L-shaped tuning key; Tune Up Oil

3 WOODCRAFT SERIES WB400 WOOD BONGOS

- SIZES** 7" Macho & 8 1/2" Hembra
- MATERIALS** American White Ash (*Fraxinus americana* L.)
True Skin Cow Heads
- FEATURES** 8 mm strong tuning lugs
3 mm rounded SSR-Rims

COLOURS **VBK-M:** Vintage Black, matte
VBR-M: Vintage Brown, matte
VR-M: Vintage Red, matte

4 WOODCRAFT SERIES BWB400 WOOD BONGO

- SIZES** 7" Macho & 8 1/2" Hembra
- MATERIALS** European Birch (*Betula pendula*)
Hand selected calf heads
- FEATURES** Natural finish European Birch shells
8 mm strong tuning lugs
3 mm rounded SSR-Rims
- COLOUR** Natural

5 WOODCRAFT SERIES WB500 WOOD BONGOS

- SIZES** 7" Macho & 9" Hembra
- MATERIALS** American White Ash (*Fraxinus americana* L.)
True Skin Cow Heads

PROFESSIONAL & FIBERCRAFT SERIES BONGOS



BONGOS

4 **REMO HEADS AVAILABLE**

European Birch, 7" & 8 1/2"
BWB400

5 **CHROME PLATED 5 MM TRADITIONAL TTR RIM**

Antique Mahogany Burst, 7" & 9"
WB500AMB

Zebra Finished Ash, 7" & 9"
WB500ZFA-M

6 **REMO HEADS AVAILABLE**

American White Ash, 7" & 8 1/2"
CS400AWA-M

7 **REMO HEADS AVAILABLE**

Natural, 7" & 8 1/2"
FWB400NT

Brown Burl, 7" & 8 1/2"
FWB400BB

8 **REMO HEADS AVAILABLE** **TRUE SKIN COW HEADS**

Black, 7" & 8 1/2"
FFB400BK

Cherry Red, 7" & 8 1/2"
FWB400CR

Gold Amber Sunburst, 7" & 8 1/2"
FWB400GAB

REMO® BLACK CALFSKIN SKYNDDEEP® HEADS **PREMIUM FIBERGLASS**

Black, 7" & 8 1/2"
FFBR400BK

FEATURES 8 mm strong tuning lugs
5 mm traditional TTR-Rims

COLOURS **AMB:** Antique Mahogany Burst, high gloss
ZFA-M: Zebra Finished Ash, matte

6 COLLECTION SERIES CS400 WOOD BONGO

SIZES 7" Macho & 8 1/2" Hembra

MATERIALS American White Ash (*Fraxinus americana* L.)
True Skin Cow Heads

FEATURES MEINL Free Ride Suspension System
Chrome plated hardware
8 mm strong tuning lugs
3 mm rounded SSR-Rims
Resonance Shaping Area

INCLUDES Accessory pouch
L-shaped tuning key
Tune Up Oil

COLOUR **AWA-M:** American White Ash, matte

7 PROFESSIONAL SERIES FWB400 WOOD BONGOS

SIZES 7" Macho & 8 1/2" Hembra

MATERIALS Siam Oak (*Hevea brasiliensis* Muell.-Arg.)
True Skin Cow Heads

FEATURES MEINL Free Ride Suspension System
Chrome plated hardware
8 mm strong tuning lugs
3 mm rounded SSR-Rims
Resonance Shaping Area

INCLUDES Accessory pouch
L-shaped tuning key
Tune Up Oil

COLOURS **BB:** Brown Burl, high gloss
CR: Cherry Red, high gloss
GAB: Gold Amber Sunburst, high gloss
NT: Natural, high gloss

8 FIBERCRAFT SERIES FIBERGLASS BONGOS

SIZES 7" Macho & 8 1/2" Hembra

MATERIALS Premium fiberglass
FFB400BK: True Skin Cow Heads
FFBR400BK: REMO® Black Calfskin Skynddeep® Heads (For more volume and resonance)

FEATURES MEINL Free Ride Suspension System
Chrome plated hardware
8 mm strong tuning lugs
3 mm rounded SSR-Rims
Resonance Shaping Area

INCLUDES Accessory pouch
L-shaped tuning key
Tune Up Oil

COLOUR **BK:** Black

WOOD, ARTIST & MARATHON® SERIES BONGOS

1 **TRADITIONAL TTR-RIM**

REMO HEADS AVAILABLE



Natural, 6 3/4" & 8"
LC300NT-M

TRADITIONAL SOLID WOODBLOCK CONSTRUCTION

2 **CHROME PLATED ROUNDED SSR RIM**



Natural, 6 3/4" & 8"
WB200NT-CH

GOLD TONE ROUNDED SSR RIM



Natural, 6 3/4" & 8"
WB200NT-G

3 **CHROME PLATED ROUNDED SSR RIM**



Natural, 6 3/4" & 8"
FWB200NT

CHROME PLATED ROUNDED SSR RIM



Super Natural, 6 3/4" & 8"
WB200SNT-M

4



Leopard Burl, 6 3/4" & 8"
FWB190LB



Gold Amber Sunburst, 6 3/4" & 8"
FWB200GAB

5



Natural, 6 3/4" & 8"
FWB190NT



Amber Flame, 6 3/4" & 8"
FWB190AF



Super Natural, 6 3/4" & 8"
FWB190SNT-M



Antique Tobacco Burst, 6 3/4" & 8"
FWB190ATB-M

1 ARTIST SERIES LC300 WOOD BONGO LUIS CONTE
SIZES 6 3/4" Macho & 8" Hembra
MATERIALS Siam Oak (*Hevea brasiliensis* Muell.-Arg.) True Skin Cow Heads
FEATURES Solid woodblock connection; Black powder coated hardware; 8 mm strong tuning lugs; 5 mm traditional TTR-Rims
INCLUDES Accessory pouch; L-shaped tuning key; Tune Up Oil
COLOUR **NT-M:** Natural, matte

2 WB200 WOOD BONGOS
SIZES 6 3/4" Macho & 8" Hembra
MATERIALS Siam Oak (*Hevea brasiliensis* Muell.-Arg.) Hand selected buffalo heads
FEATURES Solid woodblock connection; 8 mm strong tuning lugs; 2 mm rounded SSR-Rim
WB200NT-CH: Chrome plated hardware
WB200NT-G: Gold tone hardware

WB200SNT-M: Chrome plated hardware
INCLUDES Accessory pouch; L-shaped tuning key; Tune Up Oil
COLOURS **NT:** Natural, high gloss
SNT-M: Super Natural, matte

MARATHON® SERIES WOOD BONGOS
3 4 5
SIZES 6 3/4" Macho & 8" Hembra
MATERIALS Siam Oak (*Hevea brasiliensis* Muell.-Arg.) Hand selected buffalo heads
FEATURES MEINL Free Ride Suspension System; 8 mm strong tuning lugs
INCLUDES Accessory pouch; L-shaped tuning key; Tune Up Oil

3 MARATHON® EXCLUSIVE SERIES FWB200 WOOD BONGOS
FEATURES Chrome plated hardware; 2 mm rounded SSR-Rims

COLOURS **GAB:** Gold Amber Sunburst, high gloss
NT: Natural, high gloss

4 MARATHON® DESIGNER SERIES FWB190 WOOD BONGOS
FEATURES Unique designs; Black powder coated hardware; 2.5 mm rounded SSR-Rims
COLOURS **AF:** Amber Flame, high gloss
LB: Leopard Burl, high gloss

5 MARATHON® SERIES FWB190 WOOD BONGOS
FEATURES Black powder coated hardware; 2 mm rounded SSR-Rims
COLOURS **ATB-M:** Antique Tobacco Burst, matte
NT: Natural, high gloss
SNT-M: Super Natural, matte

HEADLINER®, JOURNEY & MINI WOOD BONGOS



BONGOS



Natural, 6 3/4" & 8"
HB100NT

Vintage Sunburst, 6 3/4" & 8"
HB100VSB

Wine Red Burst, 6 3/4" & 8"
HB100WRB



Vintage Wine Barrel, 6 3/4" & 8"
HB100VWB-M

Walnut Brown, 6 3/4" & 8"
HTB100WB-M

Black, 6 3/4" & 8"
HFB100BK



Black, 6 1/2" & 7 1/2"
HB50BK



Super Natural, 3 1/2" & 4 1/4"
FWB100SNT-M



Set, 4 pcs.
BPP-1

1 HEADLINER® SERIES HB100 & HTB100 WOOD BONGOS
SIZES 6 3/4" Macho & 8" Hembra
MATERIALS Siam Oak (*Hevea brasiliensis* Muell.-Arg.)
 Hand selected buffalo heads
FEATURES Black powder coated hardware
 8 mm strong tuning lugs
 Interior backing plates
HB100
 2 mm rounded rims for playing comfort
HTB100WB-M
 5 mm strong TTR-rims
INCLUDES Tuning key
COLOURS **NT:** Natural, high gloss
VSB: Vintage Sunburst, high gloss
VWB-M: Vintage Wine Barrel, matte
WB-M: Walnut Brown, matte
WRB: Wine Red Burst, high gloss

2 HEADLINER® SERIES HFB100 FIBERGLASS BONGO
SIZES 6 3/4" Macho & 8" Hembra
MATERIALS Premium fiberglass
 Hand selected buffalo heads
FEATURES Black powder coated hardware
 8 mm strong tuning lugs
 2.6 mm rounded rims
INCLUDES Tuning key
COLOUR **BK:** Black
3 JOURNEY SERIES HB50 BONGO
SIZES 6 1/2" Macho & 7 1/2" Hembra
MATERIALS ABS plastic
 Hand selected buffalo heads
FEATURES Black powder coated hardware
 Rounded rims for playing comfort
INCLUDES Tuning key
COLOUR **BK:** Black

4 BONGO & PERCUSSION PACK
CONTAINS Journey Series HB50 Bongo
 Compact Foot Tambourine
 Luis Conte Live Shaker
 Classic Wood Claves
5 FWB100 MINI WOOD BONGO
SIZES 3 1/2" Macho & 4 1/4" Hembra
MATERIALS Siam Oak (*Hevea brasiliensis* Muell.-Arg.)
 True Skin Buffalo Heads
FEATURES MEINL Free Ride Suspension System
 Chrome plated hardware
 2 mm rounded SSR-Rims
INCLUDES Tuning key
COLOUR **SNT-M:** Super Natural, matte

TIMBALES HEADS & HEADLINER®, MARATHON®, HYBRID,

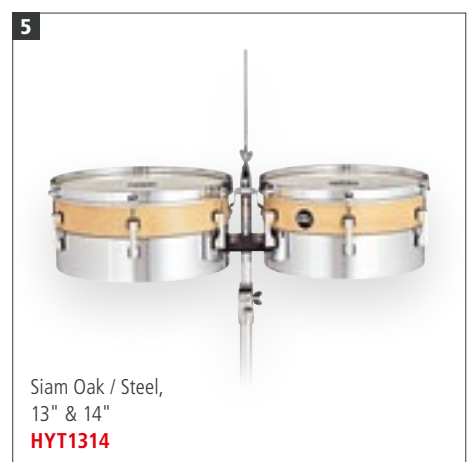

1 TIMBALES HEADS

SIZES **TBLH8BK:** 8" (Mini Timbales Head)
TBLH10BK: 10" (Mini Timbales Head)
TBLH13BK: 13"
TBLH14BK: 14"
TBLH15BK: 15"

MATERIAL Synthetic head

FEATURES Cutting and clean tone with effortless response; Extremely durable

COLOUR Black

2 HEADLINER® SERIES TIMBALES (PATENTED)

SIZES 13" & 14"

MATERIAL Steel

FEATURES Logo applied from underneath the head (CN, TH, US patent); Two worked-in flanges

INCLUDES Height adjustable tilting double braced tripod stand; Tuning key; Wrench; Cowbell holder

FINISH Chrome

3 MARATHON® SERIES TIMBALES (PATENTED)

SIZES 14" & 15"

MATERIAL Steel

FEATURES Two worked-in flanges; Heavy-duty style brackets; Logo applied from underneath the head (CN, TH, US patent)

INCLUDES Adjustable cowbell holder; Height adjustable tilting double braced tripod stand; Accessory pouch; L-shaped tuning key; Tune Up Oil

FINISHES **B:** Brass
BN: Black nickel
CH: Chrome
RR-M: Antique Finish, matte

4 MARATHON® SERIES TURBO TIMBALES (PATENTED)

SIZES 14" & 15", 10" deep

MATERIAL Black powder coated steel

FEATURES Three worked-in flanges; Heavy-duty style brackets; Logo applied from underneath the head (CN, TH, US patent)

INCLUDES Adjustable cowbell holder; Height adjustable tilting double braced tripod stand; Accessory pouch; L-shaped tuning key; Tune Up oil

COLOUR **BK:** Black

5 HYBRID TIMBALES (PATENTED)

SIZES 13" & 14"

MATERIALS Siam Oak (*Hevea brasiliensis* Muell.-Arg.) Steel

FEATURES Special designed aluminum brackets; Logo applied from underneath the head (CN, TH, US patent)

INCLUDES Adjustable cowbell holder; Height adjustable tilting double braced tripod stand; Accessory pouch; L-shaped tuning key; Tune Up Oil

ARTIST SERIES, DRUMMER TIMBALES & HAND-BALE



TIMBALES

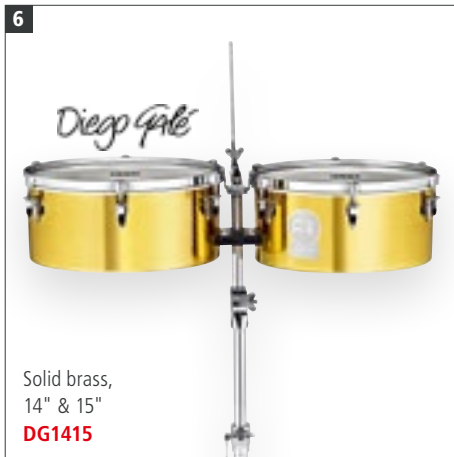

Solid brass,
14" & 15"
DG1415

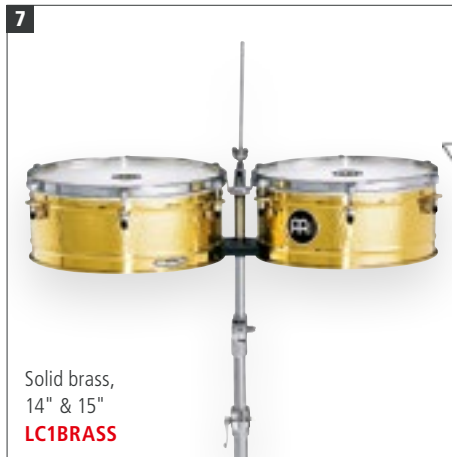

Solid brass,
14" & 15"
LC1BRASS



Stainless steel,
14" & 15"
LC1STS

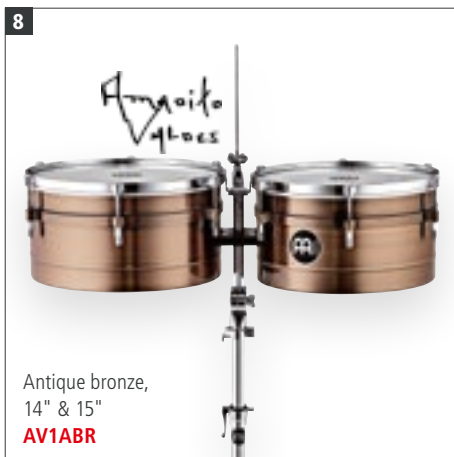

Antique bronze,
14" & 15"
AV1ABR

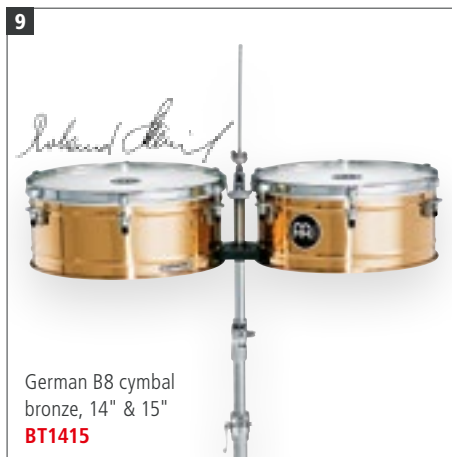

German B8 cymbal
bronze, 14" & 15"
BT1415

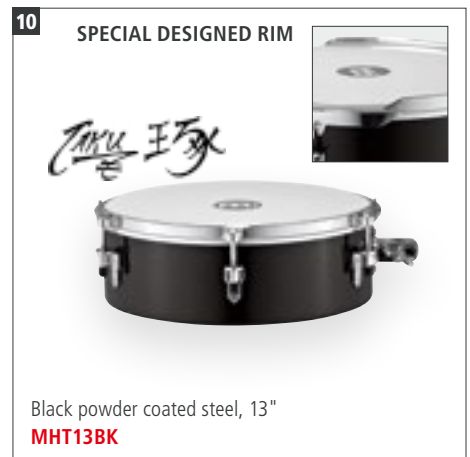

SPECIAL DESIGNED RIM

Black powder coated steel, 13"
MHT13BK

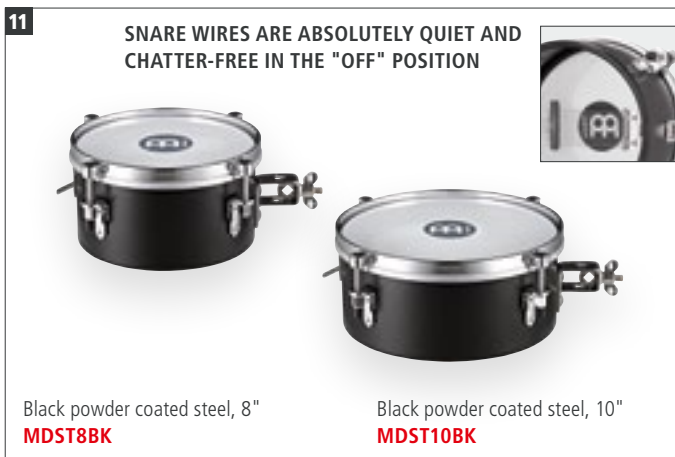

SNARE WIRES ARE ABSOLUTELY QUIET AND CHATTER-FREE IN THE "OFF" POSITION

Black powder coated steel, 8"
MDST8BK

Black powder coated steel, 10"
MDST10BK



Chrome, 8" & 10"
MIT810CH

Chrome, 13"
MDT13CH

ARTIST SERIES TIMBALES (PATENTED)

6 7 8 9

SIZES 14" & 15"

FEATURE Logo applied from underneath the head (CN, TH, US patent)

INCLUDES Adjustable cowbell holder; Accessory pouch; L-shaped tuning key; Tune Up Oil

6 ARTIST SERIES TIMBALES DIEGO GALÉ

MATERIAL Solid brass

FEATURE Classic Timbales shape and look

INCLUDES Professional Timbale Stand

7 ARTIST SERIES TIMBALES LUIS CONTE

MATERIALS **LC1BRASS**: Solid brass

LC1STS: Stainless steel

FEATURES Two worked-in flanges; Cuban style flared out bottom edge

INCLUDES Height adjustable tilting double braced tripod stand

8 ARTIST SERIES TIMBALES AMADITO VALDÉS

MATERIAL Steel

FEATURES Two worked-in flanges; Floatune Tuning System

INCLUDES Height adjustable tilting double braced tripod stand

COLOUR Antique bronze

9 PROFESSIONAL SERIES TIMBALES

MATERIAL German B8 cymbal bronze

FEATURE Two worked-in flanges

INCLUDES Height adjustable tilting double braced tripod stand

10 ARTIST SERIES HAND-BALE TAKU HIRANO (PATENTED)

SIZE 13"

MATERIAL Black powder coated steel

FEATURE Logo applied from underneath the head (CN, TH, US patent)

INCLUDES L-shaped tuning key; Tune Up Oil
COLOUR **BK**: Black, high gloss

11 DRUMMER SNARE TIMBALES (PATENTED)

SIZES 8", 10"

MATERIAL Black powder coated steel

FEATURES Quick snare on/off system; Chatter-free "off" position; Logo applied from underneath the head (CN, TH, US patent)

INCLUDES L-shaped tuning key; Tune Up Oil

COLOUR **BK**: Black

12 DRUMMER TIMBALE & MINI TIMBALES (PATENTED)

SIZES **MDT13CH**: 13" (Drummer Timbale)
MIT810CH: 8" & 10" (Mini Timbales)

MATERIAL Steel

FEATURE Logo applied from underneath the head (CN, TH, US patent)

INCLUDES L-shaped tuning key; Tune Up Oil

COWBELLS & PERCUSSION BLOCKS

1 BLACK POWDER COATED STEEL

8" **HCO2BK** 5" **HCO4BK**

2 BLACK POWDER COATED STEEL

8 1/2" **SL850-BK** 6 3/4" **SL675-BK** 5 1/4" **SL525-BK** 4 3/4" **SL475-BK**

3 EASY MOUNTABLE

2 1/2", 3 1/2", 5" **SLTRI-BK**

4 CLASSIC ROCK COWBELLS

7" big mouth, low pitch **SCL70B-BK** 4 3/4" high pitch **SCL475-BK**

TIMBALERO COWBELLS

8 1/2" low pitch **SCL850-BK** 7" high pitch **SCL70-BK**

5 HIGH POLISHED CHROME

8" big mouth **STB80B-CH** 8" small mouth **STB80S-CH** 6 1/4" **STB625-CH** 5 1/2" **STB55-CH** 4 1/2" low pitch **STB45L-CH**

HANDMATE (SEE PAGE 85)

HAM1BK

HAND BRUSHED STEEL

8" big mouth **STB80B** 8" small mouth **STB80S** 6 1/4" **STB625** 5 1/2" **STB55** 4 1/2" low pitch **STB45L** 4 1/2" medium pitch **STB45M** 4 1/2" high pitch **STB45H**

1 HEADLINER® SERIES COWBELLS

SIZES **HCO2BK**: 8" (Timbales Cowbell)
HCO4BK: 5" (Cha Cha Cowbell)

MATERIAL Special steel alloy

FEATURE Muffled sound

FINISH **BK**: Black powder coated

2 BLACK FINISH COWBELLS

SIZES **SL850-BK**: 8 1/2" (Timbales Cowbell)
SL675-BK: 6 3/4" (Medium Timbales Cowbell)
SL525-BK: 5 1/4" (Cha Cha Cowbell)
SL475-BK: 4 3/4" (Mini Cha Cha Cowbell)

MATERIAL Special steel alloy

FEATURE Muffled sound

FINISH **BK**: Black powder coated

3 TRIPLE BELL

SIZES 2 1/2", 3 1/2", 5"

MATERIAL Special steel alloy

FEATURE Muffled sound

FINISH **BK**: Black powder coated

4 STEEL CRAFT LINE COWBELLS

SIZES **SCL70B-BK**: 7" (Classic Rock Cowbell Big Mouth)
SCL475-BK: 4 3/4" (Classic Rock Cowbell)
SCL850-BK: 8 1/2" (Timbalero Cowbell)
SCL70-BK: 7" (Timbalero Cowbell)

MATERIAL Special steel alloy

FEATURES Steel alloy controls overtones and resonance
Classic cowbell sound for any setting

FINISH **BK**: Black powder coated

5 CHROME & STEEL FINISH COWBELLS

SIZES **STB80B**: 8" (Timbales Cowbell Big Mouth)
STB80S: 8" (Timbales Cowbell Small Mouth)
STB625: 6 1/4" (Medium Timbales Cowbell)
STB55: 5 1/2" (Cha Cha Cowbell)
STB45L: 4 1/2" (Low Cha Cha Cowbell)
STB45M: 4 1/2" (Medium Cha Cha Cowbell)
STB45H: 4 1/2" (High Cha Cha Cowbell)

MATERIAL Special steel alloy

FEATURE Tonally matched

FINISHES Hand brushed steel
CH: High polished chrome



6 **HAND BRUSHED GOLD**

8" big mouth **STB80BHH-G**
6 1/4" **STB625HH-G**

HAND BRUSHED STEEL

8" big mouth **STB80BHH-S**
6 1/4" **STB625HH-S**

HAND BRUSHED COPPER

8" big mouth **STB80BHH-C**
6 1/4" **STB625HH-C**

7

DEMO VIDEO

GROOVE BELL DESIGNED WITH MIKE JOHNSTON

7 3/4" **MJ-GB**

8

BLACK POWDER COATED STEEL

8" **BCOB**

9 **SPECIAL STEEL ALLOY**

8 1/4" **STB815H**
7 3/4" **STB785H**
6 1/2" **STB65H**

10

DEMO VIDEO

LOOPER BELL DESIGNED WITH YOUNGR

6 1/2" **YACB**

11 **COMFORTABLE HOLDER**

6 1/4" **STB625HA-CB**
4 1/2" **STB45HA-CB**

DRUM HONEY (SEE PAGE 83)

MDH

MAGNETIC SUSTAIN CONTROL (SEE PAGE 83)

MCT

12

High pitch **MPE3BK**

Low pitch **MPE4R**

6 HAMMERED COWBELLS

SIZES **STB80BHH:** 8" (Timbales Cowbell Big Mouth)
STB625HH: 6 1/4" (Medium Timbales Cowbell)

MATERIAL Special steel alloy

FEATURE Hammered

FINISHES **C:** Hand brushed copper
G: Hand brushed gold
S: Hand brushed steel

7 ARTIST SERIES COWBELL MIKE JOHNSTON

SIZE 7 3/4"

MATERIAL Special steel alloy

FEATURES Specifically made for drum set use

INCLUDES Two magnets (one small and one large, based on Benny Greb's Magnetic Sustain Control idea)

FINISH Vintage Steel

8 BONGO COWBELL

SIZE 8" (Medium Handheld Cowbell)

MATERIAL Special steel alloy

FEATURES Muffled sound
For low volume playing

FINISH Black powder coated

9 HAND COWBELLS

SIZES **STB815H:** 8 1/4" (High Handheld Cowbell)
STB785H: 7 3/4" (Low Handheld Cowbell)
STB65H: 6 1/2" (Mini Handheld Cowbell)

MATERIAL Special steel alloy

FINISH Hand brushed steel

10 ARTIST SERIES COWBELL YOUNGR

SIZE 6 1/2"

MATERIAL Special steel alloy

FEATURES Adjust tone and sustain with hands or included Magnetic Sustain Control
Unique art and white finish

INCLUDES Two magnets (two large, based on Benny Greb's Magnetic Sustain Control idea)

11 HANDHELD COWBELLS

SIZES **STB625HA-CB:** 6 1/4"
STB45HA-CB: 4 1/2"

MATERIAL Special steel alloy

FEATURE Comfortable holder

FINISH Hand brushed steel

12 PERCUSSION BLOCKS

MATERIAL PE

FEATURES Ultra-durable plastic
MPE3BK: High pitched sound
MPE4R: Low pitched sound

INCLUDES Mounting Clamp

COLOURS **BK:** Black
R: Red

ARTISAN EDITION RIQ DRUM & PANDEIROS

1 NEW



Synthetic head, 8 3/4"
AERIQ1

2



Clear Mylar head, 10"
PA10ABS-BK

CHROME PLATED STEEL JINGLES



Napa head, 10"
PA10ABS-BK-NH

3



Goatskin head, 10"
PA10CN-M

CHROME PLATED STEEL JINGLES

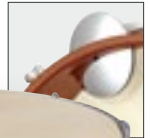

Goatskin head, 12"
PA12CN-M

4

CHROME PLATED
STEEL JINGLES



Goatskin head, 10"
PA10PW-M

5

HAND-HAMMERED
BRASS JINGLES



Goatskin head, 10"
PA10AB-M

6

PERFORATED
HAND-HAMMERED
BRASS JINGLES

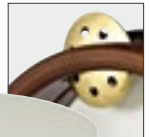

True Feel synthetic head, 10"
PAV10AB-M-TF

7

UNIQUE SHAKER PODS



Napa head, 10"
PAS10PW-NH

8

EASY MOUNTABLE



Napa head, 10"
PA10A-BK-NH-H

9

EASY MOUNTABLE

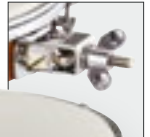

True Feel synthetic head, 12"
PA12CN-M-TF-H

1 ARTISAN EDITION RIQ DRUM

- SIZE** 8 3/4"
MATERIALS Wooden frame
Synthetic head
Ten pairs of brass jingles
FEATURES Artisan sounds for Arabic folk and classical music; Five tuning lugs
INCLUDES Tuning key
FINISH White Pearl Mosaic Royal

2 TRADITIONAL ABS PANDEIROS

- SIZE** 10"
MATERIALS ABS plastic
Chrome plated steel jingles
PA10ABS-BK
Replaceable synthetic head
PA10ABS-BK-NH
Replaceable Napa head

- FEATURES** Countersunk bolt lugs
PA10ABS-BK: Logo applied from underneath the head (CN, TH, US patent)
PA10ABS-BK-NH: Reduced overtones
INCLUDES Tuning key
COLOUR **BK:** Black

3 TRADITIONAL WOOD PANDEIROS, SIAM OAK

- SIZES** **PA10:** 10"
PA12: 12"
MATERIALS Siam Oak (*Hevea brasiliensis* Muell.-Arg.)
Replaceable hand selected goatskin head
Chrome plated steel jingles
INCLUDES Tuning key
COLOUR **CN-M:** Chestnut, matte

4 TRADITIONAL WOOD PANDEIRO, POPLAR WOOD

- SIZE** 10"

- MATERIALS** Poplar Wood (*Populus*)
Replaceable hand selected goatskin head
Chrome plated steel jingles
INCLUDES Tuning key

5 SHELL-TUNED GOATSKIN PANDEIRO

- SIZE** 10"
MATERIALS Siam Oak (*Hevea brasiliensis* Muell.-Arg.)
Hand selected goatskin head
Hand-hammered brass jingles
INCLUDES Hex key
COLOUR **AB-M:** Antique Brown, matte

6 SHELL-TUNED SYNTHETIC HEAD PANDEIRO

- SIZE** 10"
MATERIALS Siam Oak (*Hevea brasiliensis* Muell.-Arg.)
True Feel synthetic head
Perforated hand-hammered brass jingles for extra dry sound
INCLUDES Hex key

COMPACT WOOD TAMBOURINES



MIXED SOLID/HAMMERED CYMBAL BRONZE 44/38 MM
SOLID CYMBAL BRONZE 44 MM
MIXED SOLID/HAMMERED BRASS 44/38 MM
SOLID BRASS 44 MM
MIXED NICKEL PLATED/HAMMERED NICKEL PLATED STEEL 44/38 MM
NICKEL PLATED STEEL 44 MM
MIXED NICKEL PLATED STEEL/SOLID BRASS 38 MM
SOLID BRASS 38 MM
NICKEL PLATED STEEL 38 MM

STAINLESS STEEL 38 MM

BLACK PLATED STEEL 38 MM

ALUMINUM 38 MM

HAMMERED CYMBAL BRONZE 38 MM

HAMMERED BRASS 38 MM

HAMMERED NICKEL PLATED STEEL/HAMMERED BRASS 38 MM

HAMMERED NICKEL PLATED STEEL 38 MM

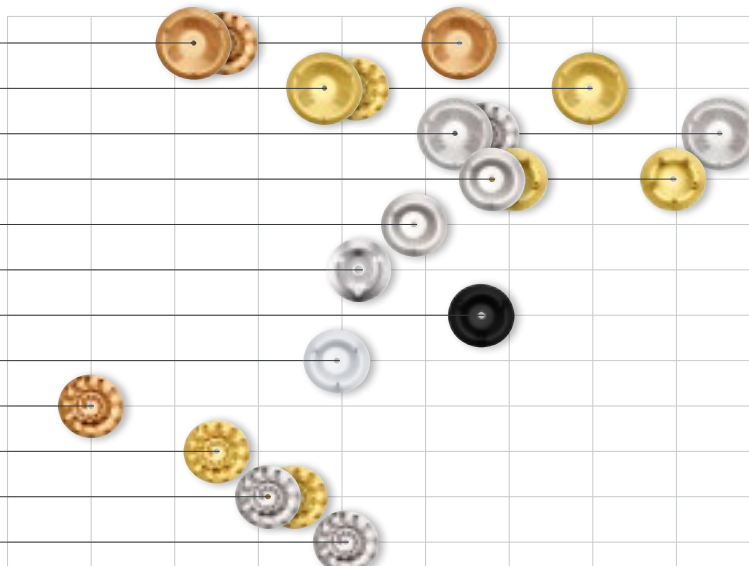

TAMBOURINE SOUND CHART

DRY

BRIGHT

<p>10</p> <p>HAMMERED BRASS</p> <p>3 rows AE-CMTA3B</p>	<p>11</p> <p>NICKEL PLATED STEEL</p> <p>2 rows CTA2S-BK</p>	<p>MIXED NICKEL PLATED STEEL / SOLID BRASS</p> <p>2 rows CTA2M-BK</p>	<p>SOLID BRASS</p> <p>2 rows CTA2B-BK</p>
<p>HAMMERED CYMBAL BRONZE</p> <p>3 rows AE-CMTA3BO</p>	<p>HAMMERED NICKEL PLATED STEEL</p> <p>3 rows AE-CATA3S</p>	<p>STAINLESS STEEL</p> <p>2 rows CTA2WB</p>	<p>MIXED HAMMERED NICKEL PLATED STEEL / BRASS</p> <p>2 rows CTA2VM-WB</p>

COLOUR **AB-M:** Antique Brown, matte

7 SHAKER PANDEIRO

SIZE 10"
MATERIALS Poplar Wood (*Populus*)
Replaceable Napa head
Aluminum shaker pods
FEATURE Countersunk bolt lugs
INCLUDES Tuning key

8 TRADITIONAL ABS PANDEIRO WITH HOLDER

SIZE 10"
MATERIALS ABS plastic
Replaceable Napa head
Chrome plated steel jingles
FEATURES Countersunk bolt lugs; Reduced overtones;
Easy mountable
INCLUDES Tuning key
COLOUR **BK:** Black

9 TRADITIONAL WOOD PANDEIRO WITH HOLDER

SIZE 12"
MATERIALS Siam Oak (*Hevea brasiliensis* Muell.-Arg.)
Replaceable True Feel synthetic head
Chrome plated steel jingles
FEATURES Countersunk bolt lugs; Reduced overtones;
Easy mountable
INCLUDES Tuning key
COLOUR **CN-M:** Chestnut, matte

10 ARTISAN EDITION COMPACT TAMBOURINES

SIZE 8"
MATERIALS **AE-CATA3:** American White Ash (*Fraxinus americana* L.)
AE-CMTA3: Maple (*Adcer* sp.)
B: Hammered brass jingles
BO: Hammered cymbal bronze jingles
S: Hammered nickel plated steel jingles

FEATURES Total unique tambourine sounds;
Resounding jingle accents; Special profile jingles; Ergonomic hand grip; Detailed with ornamental heat-branded logo;
3 rows of hammered jingles; Extra narrow jingle slots for precise playing

11 COMPACT WOOD TAMBOURINES

SIZE 8"
MATERIALS Wooden frame
CTA2B-BK: Solid brass jingles
CTA2M-BK: Nickel plated steel / solid brass jingles
CTA2S-BK: Nickel plated steel jingles
CTA2VM-WB: Hammered nickel plated steel / hammered brass jingles
CTA2WB: Stainless steel jingles
Compact size; 2 row version
FEATURES
COLOURS **BK:** Black
WB: Walnut Brown

WOOD TAMBOURINES



1 ARTISAN EDITION TAMBOURINES

SIZE 10"

MATERIALS **AE-ATA:** American White Ash (*Fraxinus americana* L.)
AE-MTA: Maple (*Adcer sp.*)
B: Solid brass jingles
BO: Solid cymbal bronze jingles
S: Nickel plated steel jingles

FEATURES Total unique tambourine sounds; Resounding tambourine accents; Special profile jingles; Ergonomic hand grip; Detailed with ornamental heat-branded logo; 1 row and 2 row version

2 VINTAGE WOOD TAMBOURINES

SIZE 10"

MATERIALS Wooden frame
TA1V: Hammered brass jingles
TA1VM: Hammered nickel plated steel / hammered brass jingles

FEATURES Legendary tambourine sound; Special profile jingles; Detailed with heat-branded logo; 1 row and 2 row version

COLOUR **WB:** Walnut Brown

3 TRADITIONAL WOOD TAMBOURINES

SIZE 10"

MATERIALS Wooden frame
TA1A-AB, TA2A-AB: Aluminum jingles
TA1B-AB, TA2B-AB: Solid brass jingles
TA1AB, TA2AB: Nickel plated steel jingles
TA1WB, TA2WB: Stainless steel jingles

FEATURES 1 row and 2 row version
TA1WB, TA2WB: Detailed with heat-branded logo

COLOURS **AB:** Antique Brown
WB: Walnut Brown

4 RECORDING-COMBO WOOD TAMBOURINES

SIZE 10"

MATERIALS Wooden frame
 Nickel plated steel / solid brass jingles
 Dual-alloy jingles; 1 row and 2 row version

FEATURES

COLOUR **SNT:** Super Natural

5 HEADED ARTISAN EDITION TAMBOURINES

SIZE 10"

MATERIALS Hand selected calfskin heads
AE-ATAH: American White Ash (*Fraxinus americana* L.)
AE-MTAH: Maple (*Adcer sp.*)
B: Solid / hammered brass jingles
BO: Solid / hammered cymbal bronze jingles
S: Nickel plated / hammered nickel plated steel jingles

4

MIXED NICKEL PLATED STEEL / SOLID BRASS

1 row **TA1M-SNT** 2 rows **TA2M-SNT**

5

MIXED SOLID / HAMMERED BRASS

MIXED SOLID / HAMMERED CYMBAL BRONZE

MIXED NICKEL PLATED / HAMMERED NICKEL PLATED STEEL

2 rows **AE-MTAH2B** 2 rows **AE-MTAH2BO** 2 rows **AE-ATAH2S**

NEW

TAMBURELLO

ALUMINUM

2 rows **FD12TAM**

7

HAMMERED BRASS

1 row **TAH1V-WB** 2 rows **TAH2V-WB**

8

BLACK PLATED STEEL

1 row **TAH1BK-R-TF** 2 rows **TAH2BK-R-TF**

9

MIXED NICKEL PLATED STEEL / SOLID BRASS

1 row **TAH1M-SNT** 2 rows **TAH2M-SNT**

10

ALUMINUM

1 row **TAH1A-AB** 2 rows **TAH2A-AB**

SOLID BRASS

1 row **TAH1B-AB** 2 rows **TAH2B-AB**

NICKEL PLATED STEEL

1 row **TAH1AB** 2 rows **TAH2AB**

STAINLESS STEEL

1 row **TAH1WB** 2 rows **TAH2WB**

FEATURES Total unique tambourine sounds; Resounding jingle accents; Two different profile jingles; Ergonomic hand grip; Detailed with ornamental heat-branded logo; Prepared with Resin

6 TAMBURELLO

SIZE 12"
MATERIALS Wooden frame
Hand selected goatskin head
Aluminum jingles

FEATURES 2 row version; Detailed with heat-branded logo; Total unique tambourine sounds

7 VINTAGE GOATSKIN WOOD TAMBOURINES

SIZE 10"
MATERIALS Wooden frame
Hand selected goatskin heads
Hammered brass jingles

FEATURES 1 row and 2 row version; Detailed with heat-branded logo
COLOUR **WB:** Walnut Brown

8 TOURING SYNTHETIC HEAD WOOD TAMBOURINES

SIZE 10"
MATERIALS Wooden frame
True Feel synthetic heads
Black plated steel jingles

FEATURE 1 row and 2 row version
COLOUR **R:** Red

9 RECORDING-COMBO GOATSKIN WOOD TAMBOURINES

SIZE 10"
MATERIALS Wooden frame
Hand selected goatskin heads
Nickel plated steel / solid brass jingles
FEATURES Dual-alloy jingles; 1 row and 2 row version

COLOUR **SNT:** Super Natural

10 TRADITIONAL GOATSKIN WOOD TAMBOURINES

SIZE 10"
MATERIALS Wooden frame
Hand selected goatskin heads
TAH1A-AB, TAH2A-AB: Aluminum jingles
TAH1B-AB, TAH2B-AB: Solid brass jingles
TAH1AB, TAH2AB: Nickel plated steel jingles
TAH1WB, TAH2WB: Stainless steel jingles

FEATURES 1 row and 2 row version
TAH1WB, TAH2WB: Detailed with heat-branded logo

COLOURS **AB:** Antique Brown
WB: Walnut Brown

JINGLE STICKS & ABS TAMBOURINES

1



HJS1BK

STAINLESS STEEL

2



JG1BK

NICKEL PLATED STEEL



JG1R

NICKEL PLATED STEEL

3

JINGLES MOUNTED ON TWO INTERSECTING PLANES



MJS1BK

MIXED NICKEL PLATED STEEL / SOLID BRASS



JG1A-B

ALUMINIUM

4



1 row, 8" **HTT8R**

1 row, 8" **HTT8WH**

1 row, 8" **HTT8BK**

2 rows, 10" **HTT10BK**

STAINLESS STEEL



JG1B-BK

SOLID BRASS



JG1M-WH

MIXED NICKEL PLATED STEEL / SOLID BRASS

1 HEADLINER® SERIES JINGLE STICKS

MATERIALS ABS plastic
Stainless steel jingles

COLOURS **BK:** Black
R: Red

2 PROFESSIONAL SERIES JINGLE STICKS

MATERIALS ABS plastic
JG1: Nickel plated steel jingles
JG1A: Aluminum jingles
JG1B: Solid brass jingles
JG1M: Nickel plated steel / solid brass jingles

FEATURES Padded grip
Güiro style playing surface

3 MULTI-JINGLE STICK

MATERIALS ABS plastic
Nickel plated steel / solid brass jingles

FEATURES Jingles mounted on two intersecting planes
Padded grip
Special playing techniques

4 HEADLINER® SERIES TOUR TAMBOURINES

SIZES **HTT8:** 8"
HTT10: 10"

MATERIALS ABS plastic
Stainless steel jingles

FEATURES Handheld
Extra wide grip
Bright, cutting sound
Durable frame

HTT8: 1 row version; Compact size
HTT10: 2 row version

COLOURS **BK:** Black
R: Red
WH: White

5 HEADLINER® SERIES HAND HELD ABS TAMBOURINES

MATERIALS ABS plastic
Stainless steel jingles

FEATURES Ergonomic hand grip for more playing comfort
Güiro style playing surface
Penetrating jingle sound
HTR, HTBK: 1 row version
HTMT1BK: 2 row version

COLOURS **BK:** Black
R: Red

ABS AND PRAISE & WORSHIP TAMBOURINES



TAMBOURINES

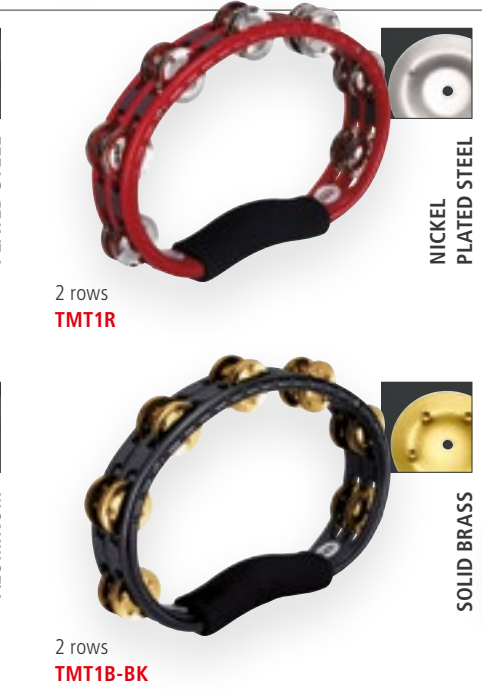

6 GOSPEL PRAISE & WORSHIP CHURCH TAMBOURINES

SIZE 10"
MATERIALS Durable frame
 Pre-tuned synthetic head
 Nickel plated steel jingles
FEATURES Perfect for worship settings with a chorus or live band
 1 row and 2 row version
FINISHES **C:** Religious Cross
D: Dove Visual

FEATURES Padded soft grip for more playing comfort
 Ergonomic design
 Güiro style playing surface
 "Sandwich" construction

COLOURS **B:** Blue
BK: Black
R: Red

8 RECORDING-COMBO HAND HELD ABS TAMBOURINE

MATERIALS ABS plastic
 Nickel plated steel / solid brass jingles
FEATURES Padded soft grip for more playing comfort
 Ergonomic design
 Güiro style playing surface
 "Sandwich" construction
COLOUR **WH:** White

9 SPEED UP TAMBOURINE

MATERIALS ABS plastic
 Nickel plated steel jingles
FEATURES Narrow elliptical shape enables fast grooves
 Ideal for fast and energetic styles
 Soft touch edge for comfortable playing feel
 Slender grip area
 Added finger and thumb holes allow you to twirl the tambourine
COLOUR Black

7 TRADITIONAL HAND HELD ABS TAMBOURINES

MATERIALS ABS plastic
TMT1A-B: Aluminum jingles
TMT1B-BK: Solid brass jingles
TMT1BK, TMT1R: Nickel plated steel jingles

ABS TAMBOURINES, CHING RINGS & CRASHERS

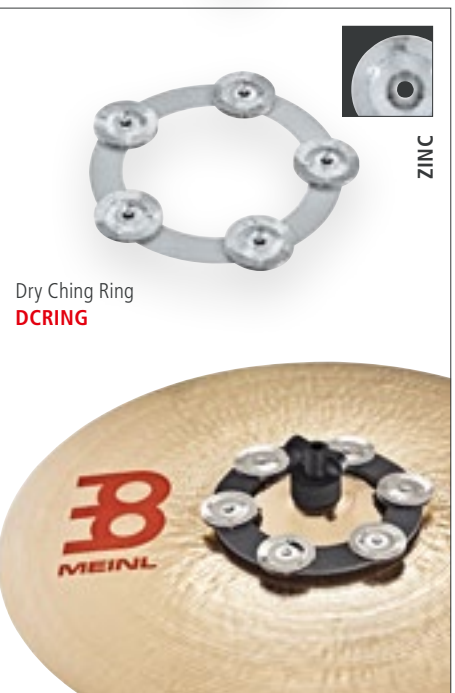
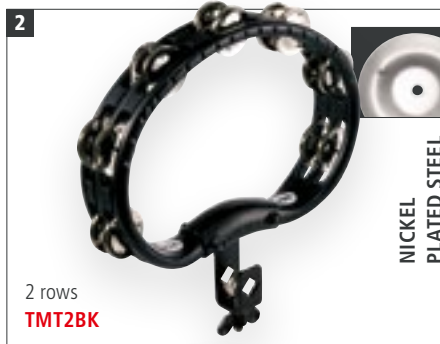

1 HEADLINER® SERIES MOUNTABLE ABS TAMBOURINE

MATERIALS ABS plastic
Stainless steel jingles

FEATURES Easy mountable
Güiro style playing surface
Penetrating jingle sound

COLOUR **BK:** Black

2 TRADITIONAL MOUNTABLE ABS TAMBOURINES

MATERIALS ABS plastic
TMT2A-B: Aluminum jingles
TMT2B-BK: Solid brass jingles
TMT2BK, TMT2R: Nickel plated steel jingles

FEATURES Easily mountable
Ergonomic design
Güiro style playing surface
"Sandwich" construction

COLOURS **B:** Blue
BK: Black
R: Red

3 RECORDING-COMBO MOUNTABLE ABS TAMBOURINE

MATERIALS ABS plastic
Nickel plated steel / solid brass jingles

FEATURES Easily mountable
Ergonomic design
Güiro style playing surface
"Sandwich" construction

COLOUR **WH:** White

4 TURBO CRASHERS

SIZES **CRASHER-M:** Medium
CRASHER: Large

MATERIAL Steel

FEATURES Güiro style playing surface
Cutting sound
Easy mountable

5 CHING RINGS

SIZE 6"

MATERIALS **CRING**
Steel ring
5 pairs of stainless steel jingles
DCRING
Steel ring
5 pairs of zinc jingles
SCRING
Foam ring
6 pairs of stainless steel jingles

FEATURES Fits on most cymbals
Quick setup

HIHAT & BACKBEAT TAMBOURINES



6



1 row
HTHH1BK

SAND HIHAT TAMBOURINE
DESIGNED WITH BENNY GREB



7



1 row
HTHH1BK

STAINLESS STEEL



2 rows
HTHH2BK

STAINLESS STEEL



1 row
HTHH1B-BK

HAMMERED BRASS



2 rows
HTHH2B-BK

HAMMERED BRASS

8



1 row
THH1BK

STAINLESS STEEL



1 row
THH1B-BK

SOLID BRASS

9



10" - 12"
BBTA1-BK

STAINLESS STEEL



13" - 14"
BBTA2-BK

10



13"
BBP13

SOLID BRASS



14"
BBP14

6 BENNY GREB SAND HIHAT TAMBOURINE

- SIZE 5"
MATERIAL Sand blasted brass jingles
FEATURES Benny Greb signature hihat tambourine
Eight pairs of sand blasted brass jingles
Dry, vintage sound with unique matte appearance
Blends easily into your natural drum set or percussion mix
Wing nut design fits on any hihat rod

7 HEADLINER® SERIES HIHAT TAMBOURINES

- SIZE 5"
MATERIALS **HTHH1BK, HTHH2BK:** Stainless steel jingles
HTHH1B-BK, HTHH2B-BK: Hammered brass jingles
FEATURES 1 row and 2 row version

8 PROFESSIONAL SERIES HIHAT TAMBOURINES

- SIZE 5"
MATERIALS **THH1BK:** Stainless steel jingles
THH1B-BK: Solid brass jingles
FEATURES Rubber padded surface

9 BACKBEAT TAMBOURINES

- SIZES **BBTA1-BK:** For 10" and 12" drums
BBTA2-BK: For 13" and 14" drums
MATERIALS Eco-friendly medium density fiberboard
Stainless steel jingles
FEATURES Fits on any standard drum
Adds a tambourine sound to the groove
Hook and loop fastener
COLOUR **BK:** Black

10 BACKBEAT PRO TAMBOURINES

- SIZES **BBP13:** 13"
BBP14: 14"
MATERIALS Cymbal brass alloy ring
Solid brass jingles
FEATURES Blackened brass ring made from MEINL Cymbal Alloy
Eight pairs of solid brass jingles

FACE SHAKERS, KEY RING SHAKERS & TAMBOURINES

1



Happy Face
FACE-H

Laughing Face
FACE-L

Poop Face
FACE-P

Face Shaker Assortment
FSA1

Sad Face
FACE-S

2



Key Ring Tambourine, red
KRT-R

Key Ring Shaker, grey
KRS-GR

Key Ring Tambourine, black
KRT-BK

Key Ring Shaker and
Tambourine Assortment
KRA1

Key Ring Shaker, black
KRS-BK

1 FACE SHAKERS

MATERIAL ABS plastic
CONTAINS **FSA1**
6 x Happy Face
6 x Laughing Face
6 x Poop Face
6 x Sad Face
FEATURES Made of durable ABS plastic
Loud filling projects clearly
Great accent for live and studio applications
INCLUDES **FSA1**: Fishbowl
GRAPHICS **FACE-H**: Happy Face
FACE-L: Laughing Face
FACE-P: Poop Face
FACE-S: Sad Face

2 KEY RING SHAKERS & KEY RING TAMBOURINES

MATERIALS ABS plastic
KRT: Nickel plated steel
KRA1
CONTAINS 10 x Key Ring Shaker
8 x Key Ring Tambourine
FEATURES Easily detach when it's time to play
Perfect for acoustic shows or jam sessions
INCLUDES **KRA1**: Fishbowl
FINISHES **BK**: Black
GR: Grey
R: Red

3 ORIGINAL SPARK SHAKER

SIZE Medium
MATERIALS Shaker: Coated steel
Pellets: Coated steel

FEATURES Circular motion enables a unique rattling
Spark Shakers may be played in pairs
FINISH Black nickel

4 SPIN SPARK SHAKER

SIZE Medium
MATERIALS Shaker: Coated steel
Pellets: Coated steel
FEATURE Screw-mounted disc enables a tunable pitch
FINISH Black nickel

5 CLAMSHELL SPARK SHAKERS

MATERIAL Steel
FEATURES Comes in a set of two
Wildly variable pitch response
FINISH Black nickel

SPARK, ALUMINUM & FIBERGLASS SHAKERS



3 CIRCULAR MOTION ENABLES A UNIQUE RATTLING



Spark shaker
SH16

4 SCREW-MOUNTED DISC ENABLES A TUNABLE PITCH



Spin spark
SH17

SENSATIONAL EFFECTS ARE PRODUCED WHEN COMBINED WITH ANOTHER SPARK SHAKER



5 HIGH PITCH & LOW PITCH



Clamshell spark, set of two
SH22

6



Headed spark
SH18

7



Small
SH8BK

Medium
SH88BK

Large
SH888BK

8



SH7-L-BK

9 BY TILTING THE SHAKER 90° TO THE FRONT THE JINGLES START TO CLICK ON THE BEAT



JS88BK

10



SH9-L-S

11



SH25-L-S

12 DESIGNED FOR PLAYING PRECISE BEATS AND PATTERNS



SH23

6 HEADED SPARK SHAKER

SIZE Medium
MATERIALS Shaker: Coated steel
 Pellets: Coated steel
 Goatskin head
FEATURES Premium goatskin and a steel shell provide a rattling combination
 Swirling effect
 Variable pitch
FINISH Black nickel

7 ALUMINUM SHAKERS, OCTAGONAL

SIZES **SH8BK**: Small
SH88BK: Medium
SH888BK: Large
MATERIAL Aluminum
FEATURE Provides a broad dynamic range with lots of volume
COLOUR **BK**: Black

8 FIBERGLASS SHAKER

SIZE Large
MATERIAL Premium fiberglass
FEATURE Made from premium fiberglass for more durability and better sound quality
COLOUR **BK**: Black

9 ALUMINUM JINGLE SHAKER

SIZE Medium
MATERIALS Shaker: Aluminum
 Jingles: Steel
FEATURE Two pairs of steel jingles are attached in one row to an octagonal aluminum shaker
COLOUR **BK**: Black

10 ALUMINUM SHAKER, ROUND

SIZE Large
MATERIAL Anodized aluminum
FEATURE Designed to cut through loud live music
COLOUR **S**: Silver

11 PROJECTION SHAKER

SIZE Large
MATERIAL Anodized aluminum
FEATURES Designed for comfort and volume
 Shimmering, cutting pitch
 Exceptional for live playing
COLOUR **S**: Silver

12 PROTON SHAKER

MATERIAL Aluminum
FEATURES Compact size
 Easy to control
 Made for precise playing techniques

PLASTIC SHAKERS & PERC PACK

1 SOFT: STUDIO



Studio shaker
SH5R



72 - 76 DB

MEDIUM: LIVE



Live shaker
SH4BK



79 - 81 DB

LOUD: STADIUM



Stadium shaker
SH45GR



88 - 93 DB

2



Set, 3 pcs.
PP-1

3



SOFT: STUDIO
Studio shaker
SH26-L-S



LOUD: LIVE
Live shaker
SH26-L-L

4



Medium
SH10-M-BK



Large
SH10-L-BK

5



Medium
SH12-M-BK



Large
SH12-L-BK

6



Medium
SH20BK

BY COVERING AND UNCOVERING THE SOUND HOLE, A "WAH-WAH" EFFECT CAN BE ACHIEVED

7

LOUD AND PENETRATING SOUND DUE TO THE MANY HOLES



SH3BK

8



Black
SH21BK



Grey
SH21GR

1 ARTIST SERIES SHAKERS LUIS CONTE

SIZE Medium
MATERIAL Plastic
FEATURES Two individual shakers connected as one instrument
SH4BK: Perfect for live playing
SH45GR: Perfect for stadium situations
SH5R: Perfect for studio recordings
COLOURS **BK**: Black
GR: Grey
R: Red

2 PERC PACK

CONTAINS Compact Foot Tambourine
 Luis Conte Live Shaker
 Classic Wood Claves
FEATURES Compact Foot Tambourine for hands free use
 Luis Conte Live Shaker for smooth sound
 Classic Wood Claves for traditional rhythms

3 CRYSTAL SHAKERS

SIZE Large
MATERIALS Plastic
 Acrylic
FEATURES Shapes any groove with clarity and feel
SH26-L-L: Perfect for live playing
SH26-L-S: Perfect for studio recordings

4 STUDIO SHAKERS

SIZES **SH10-M-BK**: Medium
SH10-L-BK: Large
MATERIAL Plastic
FEATURE Deliver a very tasteful and delicate shaker sound with a warm tone and well balanced frequency spectrum
COLOUR **BK**: Black

5 STUDIOMIX SHAKERS

SIZES **SH12-M-BK**: Medium
SH12-L-BK: Large
MATERIAL Plastic
FEATURE Textured surface for special sound and positive grip
COLOUR **BK**: Black

6 WAKAH SHAKER

SIZE Medium
MATERIALS Wooden body and plastic chamber
FEATURE By covering and uncovering the sound hole, a "wah-wah" effect can be achieved
COLOUR **BK**: Black

EGG SHAKERS



9

COMES IN A SET OF TWO

Black
ES2-BK

Red
ES2-R

Blue
ES2-B

Yellow
ES2-Y

Green
ES2-GREEN

10

RANGE OF VOLUME FROM SOFT TO EXTRA LOUD

SOFT

MEDIUM

LOUD

EXTRA LOUD

Set, 4 pcs.
ES-SET

11

NEW

Set, 24 pcs.
ES-SET24-BK

Set, 24 pcs.
ES-SET24-MC

12

EGG SHAKER ASSORTMENT

Set, 60 pcs.
ES-BOX

MOTION SHAKERS
(SEE PAGE 19)

MS-BK

MS-GR

FOOT SHAKER
(SEE PAGE 20)

FS-BK

HEEL SHAKER
(SEE PAGE 20)

HSH

7 LOOP SHAKER
 SIZE Medium
 MATERIAL Plastic
 FEATURE Loud and penetrating sound due to the many holes
 COLOUR **BK:** Black

8 U.F.O. SHAKERS
 SIZE Medium
 MATERIAL Plastic
 COLOURS **BK:** Black
GR: Grey

9 EGG SHAKER PAIRS
 MATERIAL Plastic
 FEATURE Comes in a set of two
 COLOURS **B:** Blue
BK: Black
GREEN: Green
R: Red
Y: Yellow

10 EGG SHAKER SET
 MATERIAL Plastic
 FEATURE Range of volume from soft to extra loud

11 EGG SHAKER SETS OF 24 PCS.
 MATERIAL Plastic
 FEATURES Crystal clear shaker sounds
 Durable shells
 Great for group or classroom percussion
 COLOURS **BK:** Black
MC: Multi-colour

12 EGG SHAKER BOX
 CONTAINS Holds 60 Egg Shakers:
 20 x Egg Shaker, Blue (B)
 10 x Egg Shaker, Black (BK)
 10 x Egg Shaker, Green (GREEN)
 10 x Egg Shaker, Red (R)
 10 x Egg Shaker, Yellow (Y)

SHAKERS

WOOD SHAKERS, DOUBLE SHAKER, GANZA & CAXIXIS

1

Baltic Birch
SH50

Ovangkol
SH51

CUTTING SHAKER SOUND

2

Set, 3 pcs.
SH50-SET

DIFFERENT FILLINGS

3

EXOTIC ZEBRANO TOP AND BOTTOM

Small
SH53-S

Medium
SH53-M

4

NEW

Burl Wood
SH60

DUAL INTERNAL CHAMBERS

5

SOFT

MEDIUM

LOUD

Lime
SH56

Beech
SH58

Oak
SH59

6

Double Shaker
D01

Ganza
GA2

7

Small
CAX1

Medium
CAX2

Large
CAX3

1 MINI CAJON SHAKERS

SIZE 2" W x 2 3/4" H x 2" D

MATERIALS Resonating body: Baltic Birch (*Betula pendula*)
SH50
Frontplate: Baltic Birch (*Betula pendula*)
SH51

FEATURES Compact size; Cutting shaker sound; Miniature size of a MEINL cajon

2 MINI CAJON SHAKER SET

MATERIALS Resonating body: Baltic Birch (*Betula pendula*)
Frontplates: Exotic Zebrano, Burl Wood, Baltic Birch (*Betula pendula*)

FEATURES Three unique timbres for multiple sound options; Various frontplates for easy identification

3 WOOD SHAKERS, RECTANGLE

SIZES **S:** Small
M: Medium

MATERIALS Baltic Birch (*Betula pendula*)
Top and Bottom: Exotic Zebrano

FEATURES Wide sound options; Rectangle shaped

4 DUAL CHAMBER SHAKER

MATERIAL Baltic Birch Plywood (*Betula pendula*)
Top and Bottom: Burl Wood

FEATURES Dual internal chambers for greater shaker control; Easier to play consistent shaker patterns; Ultra-smooth sound

5 WOOD SHAKERS, ROUND

SIZE 4" length, 1 3/4" diameter

MATERIALS **SH56:** Lime
SH58: Beech
SH59: Oak

FEATURES Made from three wood species for different volume; Fits comfortably in your hand
SH56: Soft
SH58: Medium
SH59: Loud

6 DOUBLE SHAKER & GANZA

MATERIALS Rattan with coconut bottom

FEATURES **D01:** Offers two different sounds in one instrument
GA2: Crystal clear sound, high pitched with a great projection

7 CAXIXIS

SIZES **CAX1:** Small
CAX2: Medium
CAX3: Large

MATERIALS Rattan with coconut bottom

FEATURES Crystal clear sound, high pitched with a great projection; Woven by hand

MARACAS

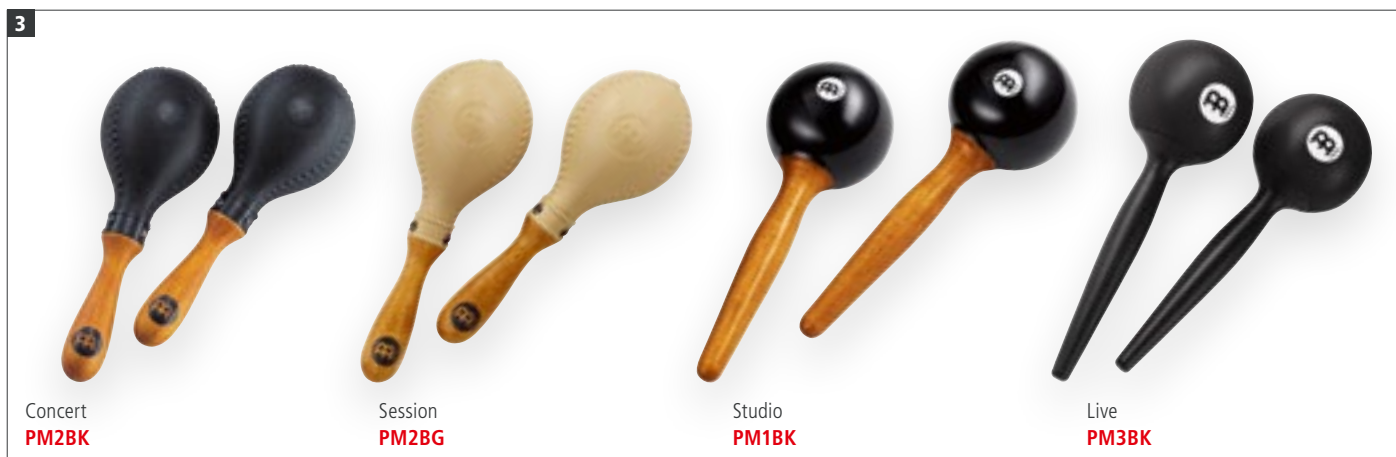

1 RAWHIDE MARACAS

SIZES **MSM2:** Mini
MSM3: Traditional
MSM4: Jumbo

MATERIALS Natural rawhide and wooden handle

FEATURES Entirely made by hand
Offers a wide sonic range
Durable construction

2 PLASTIC EGG MARACAS

SIZE 6"

MATERIAL Plastic

FEATURE Ergonomically shaped handle

3 CONCERT, SESSION, STUDIO & LIVE MARACAS

MATERIAL Plastic heads

FEATURE Ergonomically shaped handle

COLOURS **BG:** Beige
BK: Black

4 WOOD MARACAS

MATERIAL Wood

FEATURES Produces a traditional warm and rich sound
Available in both round and oval models

5 MARACLAVES

MATERIALS American Ash wood (*Fraxinus americana* L.)
Plastic shaker head

FEATURES Can be played like maracas and claves at the same time
Precise and cutting sounds
Durable construction
Detailed with logo heat-branded on handle

COLOUR **BG:** Beige



NATE WERTH, USA

ALUMINUM SURDOS

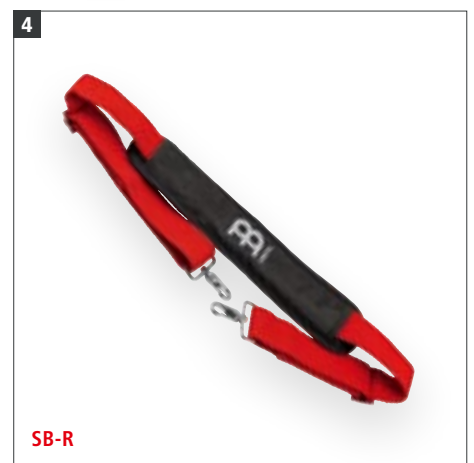

1 CLASSIC SERIES SURDOS (PATENTED)

SIZES **SUC16:** 16" diameter, 20" tall
SUC18: 18" diameter, 22" tall
SUC20: 20" diameter, 24" tall

MATERIAL Aluminum

FEATURES Countersunk bolt heads
Traditional rim
Chrome plated hardware
Traditional plain shell
8 tuning lugs (16" & 18" models)
10 tuning lugs (20" model)
Logo applied from underneath the head
(CN, TH, US patent)

INCLUDES Tuning key

2 BAHIA ALUMINUM SURDOS (PATENTED)

SIZES **SUB18:** 18" diameter, 16" tall
SUB20: 20" diameter, 16" tall
SUB22: 22" diameter, 18" tall

MATERIAL Aluminum

FEATURES Countersunk bolt heads
Chrome plated hardware
Two head options
8 tuning lugs (18" model)
10 tuning lugs (20" & 22" models)
Logo applied from underneath the head
(CN, TH, US patent)

INCLUDES Tuning key

3 TRADITIONAL ALUMINUM SURDOS (PATENTED)

SIZES **SU16:** 16" diameter, 20" tall
SU18: 18" diameter, 22" tall
SU20: 20" diameter, 24" tall
SU22: 22" diameter, 24" tall

MATERIAL Aluminum

FEATURES Countersunk bolt heads
Chrome plated hardware
Two head options
8 tuning lugs (16" & 18" models)
10 tuning lugs (20" & 22" models)
Logo applied from underneath the head
(CN, TH, US patent)
SU22-L, SU20-L, SU18-L, SU16-L:
Height adjustable legs

INCLUDES Tuning key



22" **HEAD-69** 20" **HEAD-68** 18" **HEAD-67** 16" **HEAD-66**



SHORTER SHELLS ENABLE TO WEAR IN MUCH LOWER POSITION

22" **SUB22AB-M** 20" **SUB20AB-M** 18" **SUB18AB-M**



22" **SU22AB-M** 20" **SU20AB-M** 18" **SU18AB-M** 16" **SU16AB-M**

SIX-PLY HARDWOOD SHELLS FOR A FULL AND WARM SOUND

SAMBA BEATERS (SEE PAGE 85)



SB1 **SB5** **SB6**



22" **SU22-L-AB-M** 20" **SU20-L-AB-M** 18" **SU18-L-AB-M** 16" **SU16-L-AB-M**

HEIGHT ADJUSTABLE LEGS

RITMO FACTORY, CZECH REPUBLIC



4 SAMBA BELT

MATERIAL Cotton
FEATURES Length adjustable
 Adjustable shoulder padding
 Strong attachment hooks
COLOUR **R:** Red

5 SURDO NAPA HEADS

SIZES **HEAD-66:** 16"
HEAD-67: 18"
HEAD-68: 20"
HEAD-69: 22"
MATERIALS Nylon and leather cloth
FEATURE Bonded in a hoop
COLOUR Black

6 BAHIA WOOD SURDOS (PATENTED)

SIZES **SUB18:** 18" diameter, 16" tall
SUB20: 20" diameter, 16" tall
SUB22: 22" diameter, 18" tall
MATERIAL Six-ply hardwood shells
FEATURES Countersunk bolt heads
 Chrome plated hardware
 Two head options
 8 tuning lugs (18" model)
 10 tuning lugs (20" & 22" models)
 Logo applied from underneath the head (CN, TH, US patent)
INCLUDES Tuning key
COLOUR **AB:** Antique Brown
FINISH Matte

7 TRADITIONAL WOOD SURDOS (PATENTED)

SIZES **SU16:** 16" diameter, 20" tall
SU18: 18" diameter, 22" tall
SU20: 20" diameter, 24" tall
SU22: 22" diameter, 24" tall
MATERIAL Six-ply hardwood shells
FEATURES Countersunk bolt heads
 Chrome plated hardware
 Two head options
 8 tuning lugs (16" & 18" models)
 10 tuning lugs (20" & 22" models)
 Logo applied from underneath the head (CN, TH, US patent)
SU22-L, SU20-L, SU18-L, SU16-L: Height adjustable legs
INCLUDES Tuning key
COLOUR **AB:** Antique Brown
FINISH Matte

TIMBAS, TANTAM, REBOLO, REPINIQUES & CUICAS

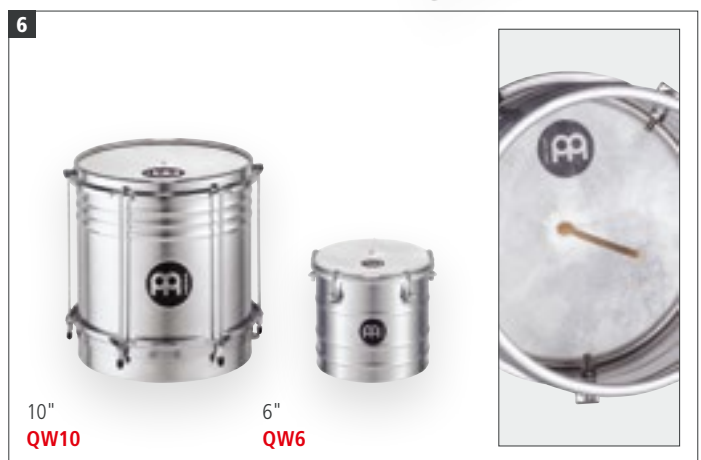
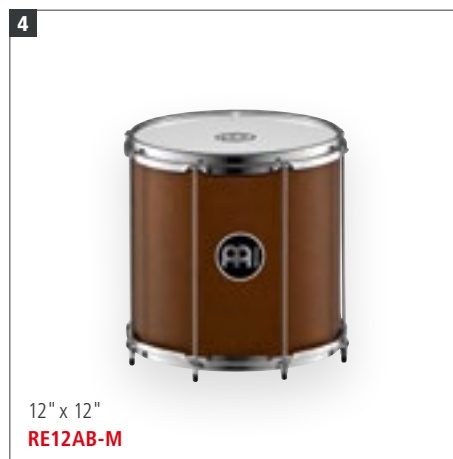
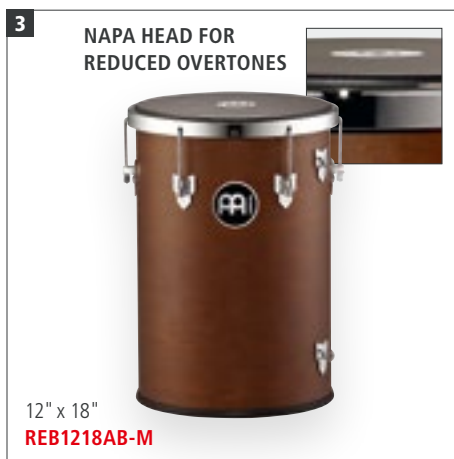
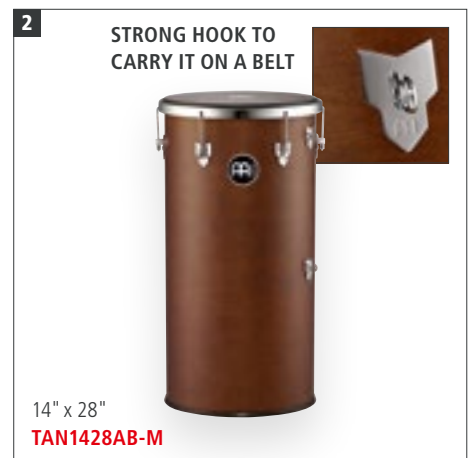

1 TIMBAS (PATENTED)

SIZES **TIM1428:** 14" diameter, 28" tall
TIM1435: 14" diameter, 35" tall

MATERIALS Poplar Wood (*Populus*)
Replaceable synthetic head

FEATURES Lightweight shell; Chrome plated hardware; Comfortable rounded rim; Strong hook to carry it on a belt; Logo applied from underneath the head (CN, TH, US patent)

INCLUDES Tuning key
COLOURS **AB:** Antique Brown, matte
NT: Natural, high gloss

2 TANTAM

SIZE 14" diameter, 28" tall
MATERIALS Poplar Wood (*Populus*)
Replaceable synthetic Napa head
FEATURES Lightweight shell; Chrome plated hardware; Strong hooks to carry it on a belt

INCLUDES Tuning key
COLOUR **AB:** Antique Brown, matte

3 REBOLO

SIZE 12" diameter, 18" tall
MATERIALS Poplar Wood (*Populus*)
Replaceable synthetic Napa head
FEATURES Lightweight shell; Chrome plated hardware; Mechanical lug tuning; Strong hooks to carry it on a belt

INCLUDES Tuning key
COLOUR **AB:** Antique Brown, matte

REPINIQUES 4 5

FEATURES Countersunk bolt heads; Chrome plated hardware; 6 tuning lugs (10" model); 8 tuning lugs (12" model); Logo applied from underneath the head (CN, TH, US patent)
INCLUDES Tuning key

4 WOOD REPINIQUE (PATENTED)

SIZE 12" diameter, 12" tall
MATERIALS Siam Oak (*Hevea brasiliensis* Muell.-Arg.)
Replaceable synthetic heads
COLOUR **AB:** Antique Brown, matte

5 ALUMINUM REPINIQUES (PATENTED)

SIZES **RE10:** 10" diameter, 10" tall
RE12: 12" diameter, 12" tall
MATERIALS Aluminum
Replaceable synthetic heads

6 ALUMINUM CUICAS

SIZES **QW6:** 6" diameter
QW10: 10" diameter
MATERIALS Aluminum
Hand selected goatskin heads
FEATURE **QW10:** Countersunk bolt heads
INCLUDES Tuning key

CAIXAS, TAMBORIMS & TAMPEIRO



SAMBA

7



**PROFESSIONAL SNARE
THROW-OFF MECHANISM**



14" x 4"
CA14



12" x 4 1/2"
CA12

8

**TRADITIONAL STYLE
WITH GUITAR STRINGS**



12" x 6"
CA12T

9

**MESH HEAD FOR SUPER LOW VOLUME
PRACTICE**



ABS, Black
STBR06ABS-BK

10



ABS, Black
TBR06ABS-BK



ABS, Green
TBR06ABS-GR

**TAMBORIM STICKS
(SEE PAGE 84)**



TBRs-BK **TBRs-R**



ABS, Red
TBR06ABS-R



ABS, Yellow
TBR06ABS-Y

**PROFESSIONAL TAMBORIM
BAG (SEE PAGE 98)**



MTAB-06



Aluminum
TBR06ALU

11



Siam Oak, Antique Brown
TP06AB-M

7 ALUMINUM CAIXAS (PATENTED)

SIZES **CA12:** 12" diameter, 4 1/2" tall
CA14: 14" diameter, 4" tall

MATERIALS Aluminum; Replaceable synthetic heads
FEATURES Countersunk bolt heads; Steel snare wires; Professional snare throw-off mechanism; Logo applied from underneath the head (CN, TH, US patent)
INCLUDES Tuning key

8 TRADITIONAL ALUMINUM CAIXA (PATENTED)

SIZE 12" diameter, 6" tall
MATERIALS Aluminum; Replaceable synthetic heads
FEATURES Traditional style snares made from guitar strings; Extra deep body; Countersunk bolt heads; Logo applied from underneath the head (CN, TH, US patent)
INCLUDES Tuning key

9 SILENT TAMBORIM

SIZE 6" diameter
MATERIALS ABS plastic
Replaceable mesh head
FEATURE Floatune Tuning System; Countersunk bolt lugs; Mesh head for super low volume practice
INCLUDES Washer as tuning key
COLOUR **BK:** Black

10 FLOATUNE TAMBORIMS (PATENTED)

SIZE 6" diameter
MATERIALS Replaceable synthetic heads
ABS: ABS
ALU: Aluminum
FEATURES Floatune Tuning System; Countersunk bolt lugs; Logo applied from underneath the head (CN, TH, US patent)
INCLUDES Washer as tuning key

COLOURS **BK:** Black
GR: Green
R: Red
Y: Yellow

11 TAMPEIRO (PATENTED)

SIZE 6" diameter
MATERIALS Siam Oak (*Hevea brasiliensis* Muell.-Arg.)
Replaceable synthetic head
Three pairs of steel jingles
FEATURES Floatune Tuning System; Countersunk bolt lugs; Logo applied from underneath the head (CN, TH, US patent)
INCLUDES Washer as tuning key
COLOUR **AB:** Antique Brown

WHISTLE, TRIANGLE, ROCARS, SHAKERS & A-GO-GOS

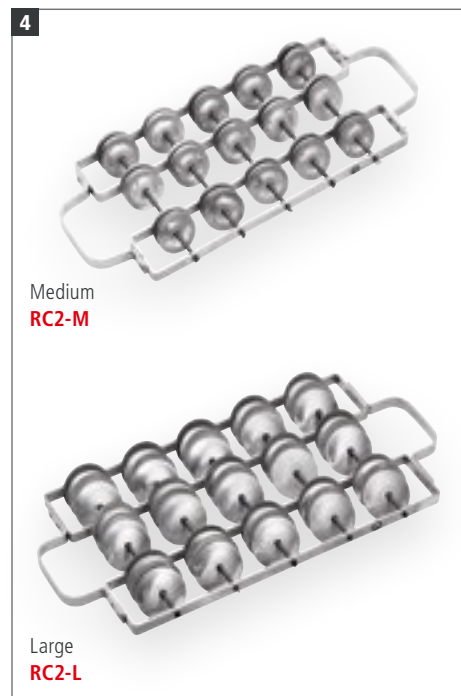
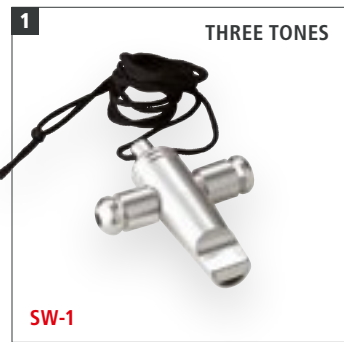

1 SAMBA WHISTLE

MATERIAL Aluminum
INCLUDES Neck lanyard

2 SAMBA TRIANGLE

SIZE 15 3/4"
MATERIAL Steel
FEATURE Thick steel for extra volume
INCLUDES Extra large Triangle Beater

3 MODERN STYLE ROCAR

MATERIAL Siam Oak (*Hevea brasiliensis* Muell.-Arg.)
FEATURE 20 pairs of solid jingles
COLOUR **BK**: Black

4 ALUMINUM ROCARS

SIZES **RC2-M**: Medium
RC2-L: Large
MATERIAL Aluminum frame and jingles
FEATURES Light weight frame; Loud projection

5 ALUMINUM SAMBA SHAKERS

SIZES **S**: Small
M: Medium
L: Large

MATERIAL Aluminum
FEATURE Produces warm and cutting shaker sound

6 MODERN STYLE A-GO-GO STEEL FINISH MODELS

SIZES **STBAG1, STBAG5**: Small
STBAG2: Large
MATERIAL Special steel alloy
FEATURE Tonally matched
INCLUDES **STBAG1**: Mounting clamp
FINISHES **STBAG1, STBAG2**: Hand brushed steel
STBAG5: Black powder coating

7 MODERN STYLE A-GO-GO CHROME FINISH MODELS

SIZES **STBAG4**: Small
STBAG2: Large
MATERIAL Special steel alloy
FEATURES Flexible connection; Bright sound
FINISH High polished chrome

8 TRADITIONAL STYLE A-GO-GO BELL

SIZE Medium
MATERIAL Special steel alloy
FEATURES Traditional shape; Flexible connection
FINISH High polished chrome

9 TRIPLE A-GO-GO BELL

SIZE Medium
MATERIAL Chrome plated steel
FEATURES Traditional Shape; Three tonally matched bells in equal intervals; Spring handle enables counterpoint rhythms

GÜIRAS, GÜIROS & WOOD BLOCKS



SAMBA & HAND PERCUSSION

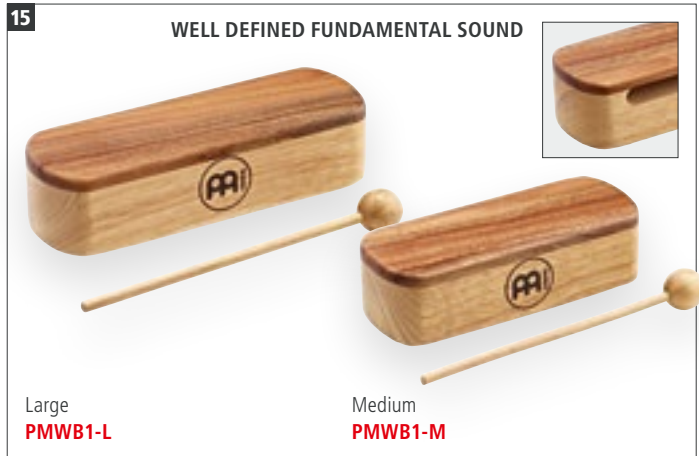

10 MERENGUE GÜIRAS

SIZES **MGU4:** X-Small
MGU3: Small
MGU2: Medium
MGU1: Large

MATERIAL Brushed steel

FEATURES Scraping surface with uniform raised bumps
One-piece metal grip with welded flanges

INCLUDES ABS scraper MGS2

11 MERENGUE GÜIRA SHAKER

MATERIAL Brushed steel

FEATURES Filling inside to produce a cutting shaker effect
Scraping surface with uniform raised bumps
One-piece metal grip with welded flanges

INCLUDES ABS scraper MGS2

12 TURBO GÜIRO

MATERIAL High strength plastic

FEATURES Three striking surfaces
Rubber ringed grip holes

INCLUDES Plastic scraper

13 FIBERGLASS GÜIROS

MATERIAL Premium fiberglass

FEATURES Three striking surfaces
Padded grip holes

INCLUDES **GU7BK:** Plastic scraper
GU7BR: Wooden scraper

COLOUR **BK:** Black
BR: Brown

14 WOOD GÜIRO

MATERIAL Wood

FEATURE Grip holes

INCLUDES Wooden scraper

COLOUR **AM:** Amber

15 PROFESSIONAL WOOD BLOCKS

SIZES **M:** Medium
L: Large

MATERIALS Select Hardwood top
Siam Oak body
(*Hevea brasiliensis* Muell.-Arg.)

FEATURES Well defined fundamental sound
Detailed with heat-branded logo

INCLUDES Wooden beater

16 WOOD BLOCKS

SIZES **MWB1BK:** Medium
MWB2BK: Large

MATERIAL Siam Oak (*Hevea brasiliensis* Muell.-Arg.)

FEATURE Rounded playing surface

INCLUDES Wooden beater

COLOUR **BK:** Black, matte

CABASAS, SLEIGH BELLS & KALIMBAS

1 ADJUSTABLE NET FOR VARIOUS TENSIONS AND SOUND OPTIONS



CA7BR

2 PORTS FOR MORE VOLUME (PATENTED)



Large **CA5BK-L** Medium **CA5BK** Small **CA5BK-S** X-Small **PCA5BK-XS**

3 **NEW** STEEL BELLS



36 bells **SLB36** 25 bells **SLB25** 12 bells **SLB12** 7 bells **SLB7**

PICKUP KALIMBA (SEE PAGE 03)



KA9P-AB

4



Small **KA5-S** Medium **KA7-M-BK** Medium **KA9-M**

5 WIDE OPENING FOR GREAT WAH-WAH EFFECTS



Medium **KA9WW-BK**

1 CABASA, FIBERGLASS

MATERIAL Premium fiberglass
FEATURES Adjustable net for various tensions and sound options
 Equals a traditional gourd calabash
COLOUR **BR:** Brown

2 TURBO CABASAS (PATENTED)

SIZES **PCA5BK-XS:** X-Small
CA5BK-S: Small
CA5BK: Medium
CA5BK-L: Large
MATERIALS Steel chain and stainless steel cylinder
CA: Wooden handle with padded soft grip
PCA: Synthetic grip
FEATURE 5 sound ports on each side for more volume (CN, DE, US patent)
COLOUR **BK:** Black

3 SLEIGH BELLS

SIZES **SLB7:** 7 bells
SLB12: 12 bells
SLB25: 25 bells
SLB36: 36 bells
MATERIALS Steel bells
 Wooden handle
FEATURES Ergonomic grip
 True sleigh bell sound
SLB36: Double handle

4 SOLID KALIMBAS

SIZES **KA5-S:** Small
KA7-M-BK: Medium
KA9-M: Medium
MATERIALS Chrome plated steel
 New Zealand Pine (*Pinus radiata*)
TUNING **KA5-S:** g#, c', f', c''
KA7-M-BK: e', g, d'', e, c', a, a'
KA9-M: a', c', c', a', A, f', e', e'', b'

FEATURES Ergonomic shape
KA5-S, KA9-M: Detailed with heat-branded logo
KA7-M-BK: Extra wide tongues for comfort

5 WAH-WAH KALIMBA

SIZE Medium
MATERIALS Chrome plated steel
 New Zealand Pine (*Pinus radiata*)
TUNING a', c', c', a', A, f', e', e'', b'
FEATURE Wah-wah effect
COLOUR **BK:** Black

CASTANETS & CLAVES



HAND PERCUSSION

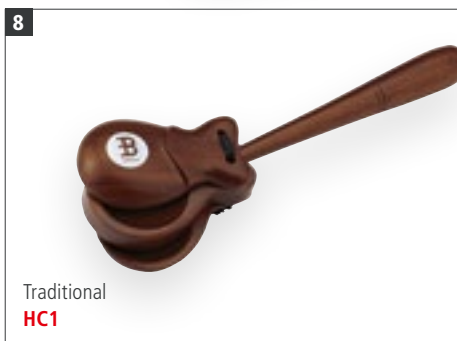

6 CASTANET MACHINE

SIZE 7 1/2" x 5"
 MATERIAL Indian Rosewood
 FEATURES Separately adjustable
 Full and cutting resonance

7 FINGER CASTANETS

SIZES **FC1:** Traditional
FC2: Concert
 MATERIAL Indian Rosewood
 FEATURE Full and cutting resonance

8 TRADITIONAL HAND CASTANET

SIZE Traditional
 MATERIAL Indian Rosewood
 FEATURES Balanced handle
 Precisely formed contours for clear, distinct sound

9 WOOD CLAVES, CLASSIC

MATERIALS **HW:** Hardwood
RW: Select Hardwood
 FEATURE Solid body

10 CLAVES DE LUXE

SIZE 6 3/4" long
 MATERIAL Dense hardwood
 FEATURES Cutting sound
 Convenient carrying

11 WOOD CLAVES, AFRICAN

MATERIALS **HW:** Hardwood
RW: Select Hardwood
 FEATURES **CL2:** Solid body
CL3: Hollowed out body

SOUND EFFECTS



1 BIRDS & WATERFALLS

MATERIALS **BI7RY, WA7BK:** Premium fiberglass
BI1NT, WA1NT, BI2NT, WA2NT: Siam Oak (*Hevea brasiliensis* Muell.-Arg.)

FEATURES Durable cord
BI: Realistically imitate the sound of a flock of birds; Bright sound with big dynamic range
WA: Realistically imitate the sound of a rippling waterfall

COLOURS **BK:** Black
NT: Natural
RY: Red/Yellow

2 AJUCH BELLS

SIZES 30" long
MABS: Small bells
MABM: Medium bells
MABL: Large bells

MATERIAL Brass and synthetic wax

FEATURES Cast bells; Solid hook for easy attachment; Synthetic wax rope

INCLUDES Canvas pouch for safe and simple storage

COLOURS **MABS:** Brown and Turquoise
MABM: Black
MABL: Dark Red and Gold

3 KOKIRIKO

MATERIAL Wood

FEATURES Ergonomically shaped handle; Durable cord

COLOUR **AM:** Amber

4 WOODEN FROGS

SIZES **M:** Medium; **L:** Large

FEATURE Authentic "ribbit" sound

5 TRIANGLES

SIZES **TRI10B:** 4"
TRI15B: 6"
TRI20B: 8"

MATERIAL Solid brass

INCLUDES Wooden holder with braided nylon cord
 Metal beater

6 THE NIGHT

MATERIALS Solid steel balls and cylinder
 Wooden body

FEATURES Unique sound of crickets;
 Ergonomically shaped handle

COLOUR **AM:** Amber

7 THE ROAR

MATERIAL Wood

FEATURE Rattling sustain

8 STAND ALONE BELL TREE

MATERIAL Solid brass bells

FEATURE Adjustable metal stand

INCLUDES Striker

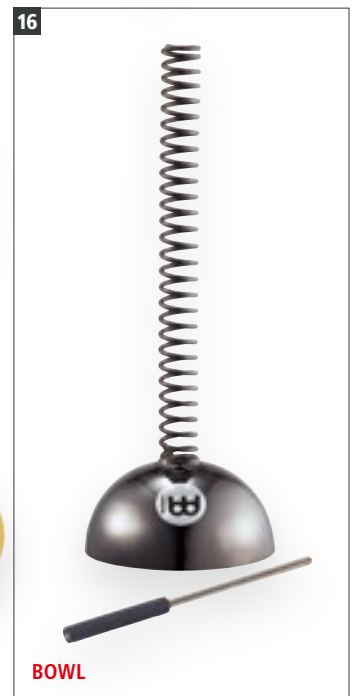
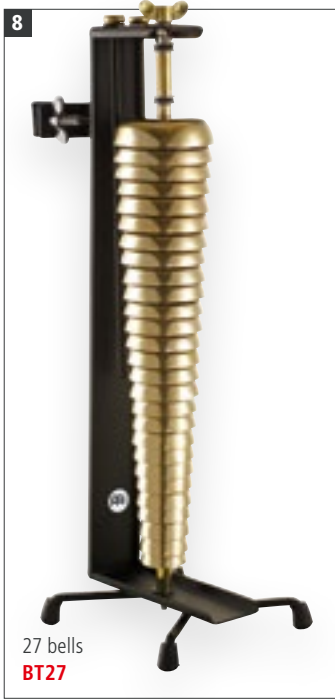

9 HAND HELD BELL TREE

MATERIAL Solid brass bells
INCLUDES Striker

10 HANGING FINGER CYMBALS

SIZES 2 3/8" diameter
MATERIAL Special bronze alloy
FEATURES Shimmering sound; Durable cord

11 PROFESSIONAL FINGER CYMBALS

SIZE 2 5/8" diameter
MATERIAL Special bronze alloy
FEATURES Identical, high pitched sound; Durable cord

12 ORIENTAL FINGER CYMBALS

SIZE 2 3/8" diameter
MATERIAL Special bronze alloy
FEATURES Identical in pitch; Durable rubber band connection

BILL SARAGOSA LINE 13 14 15 16

MATERIAL Special steel alloy
FEATURE Wide sound spectrum
FINISH Black nickel

13 LIQUID TRIANGLE

FEATURES The triangle portion may be played in the classical manner, while the chamber creates eerie resonant overtones; Special steel alloy, filled with water
INCLUDES Metal beater

14 CONE-STACK

FEATURES Fourchambered shaker with some wild characteristics; Get a kind of multi-chambered stereo effect; A set of two

15 GALAXY

FEATURES Two resonant liquid chambers are connected by a long steel spiral liquid inside

INCLUDES the two chambers exerts variable dampening on the thin steel resonator plates
Metal beater

16 HELIX BOWL

FEATURES Wonderful instrument consisting of a steel helix welded to a resonating chamber; Deep resonating wah-wah effect
INCLUDES Metal beater

17 WAH-WAH TUBES

SIZE Large (low pitch)
MATERIAL Aluminum
INCLUDES Rubber mallet
COLOUR **BK:** Black

18 RHYTHM BELL

SIZE 8 1/2"
MATERIAL Special cast alloy
FEATURES Cutting bell sound; Very long sustain

CHIMES

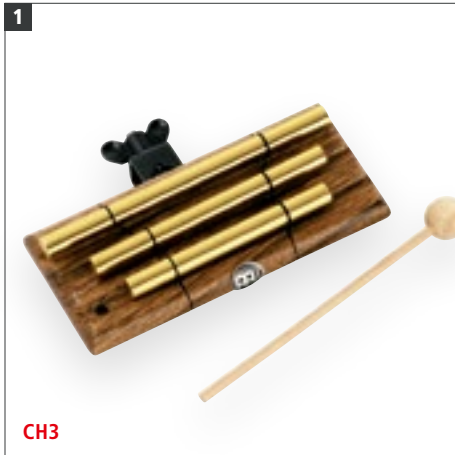

CH3



12 bars
CH-H12

18 bars
CH-H18

24 bars
CH-H24



12 pegs
CH-HPEG



27 bars, single row
HCH1R



33 bars, single row
HCH2BK



27 bars, single row
CH27VWB

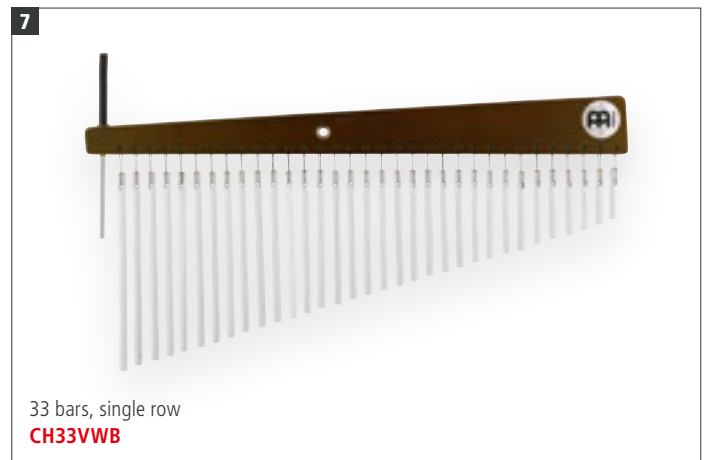

33 bars, single row
CH33VWB

1 TRI TONE CHIMES

- MATERIAL** Gold anodized aluminum alloy
- FEATURES** Three free-floating bars create a very long sustain
Tonally matched bars
Mountable on all common L-rods
- INCLUDES** Wooden beater and holder

2 HAND CHIMES

- SIZES** **CH-H12:** 12 bars
CH-H18: 18 bars
CH-H24: 24 bars
- MATERIAL** Gold anodized aluminum alloy
- FEATURES** Can easily be played by hand
Produce a full and rich sound

3 PEG CHIMES

- SIZE** 12 pegs
- MATERIAL** Gold plated steel
- FEATURE** Perfect for special accents

4 HEADLINER® SERIES CHIMES, 27 BARS

- SIZE** 27 bars, single row
- MATERIAL** Silver anodized aluminum alloy
- FEATURES** Great and affordable addition to any percussion set-up
Produce a full and warm chime sound
- COLOUR** **R:** Red

5 HEADLINER® SERIES CHIMES, 33 BARS

- SIZE** 33 bars, single row
- MATERIAL** Silver anodized aluminum alloy
- FEATURE** Generate a full sound spectrum
- COLOUR** **BK:** Black

6 VINTAGE CHIMES, 27 BARS

- SIZE** 27 bars, single row
- MATERIAL** Silver anodized aluminum alloy
- FEATURE** Excellent addition to any drum or percussion arrangement
- COLOUR** **VWB:** Vintage Wine Barrel

7 VINTAGE CHIMES, 33 BARS

- SIZE** 33 bars, single row
- MATERIAL** Silver anodized aluminum alloy
- FEATURES** Can be used in a wide range of musical styles
Producing a sweet sparkling sound
- INCLUDES** Holder; Striker
- COLOUR** **VWB:** Vintage Wine Barrel

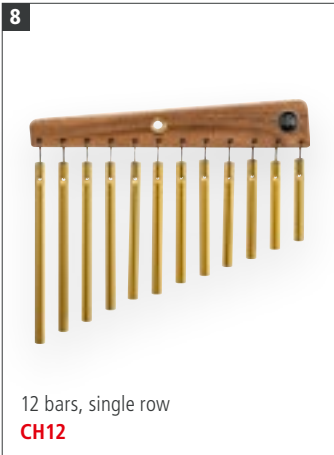

12 bars, single row
CH12



27 bars, single row
CH27ST



27 bars, single row
CH27

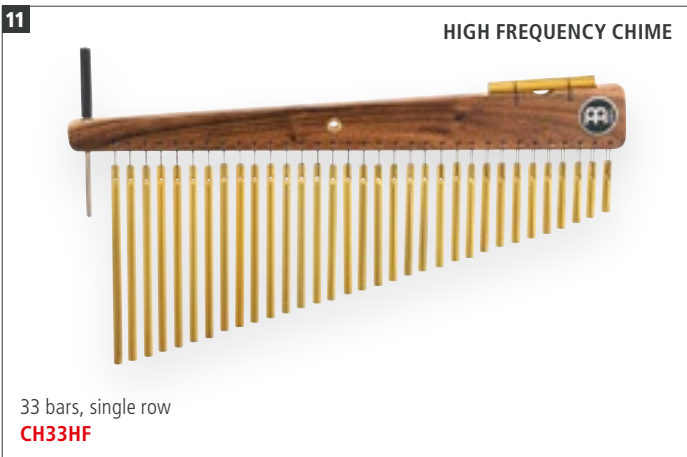

33 bars, single row
CH33HF



66 bars, double row
CH66HF



ALL BARS ARE ATTACHED THROUGH A NYLON CORD



60 bars, double row
LC60HF

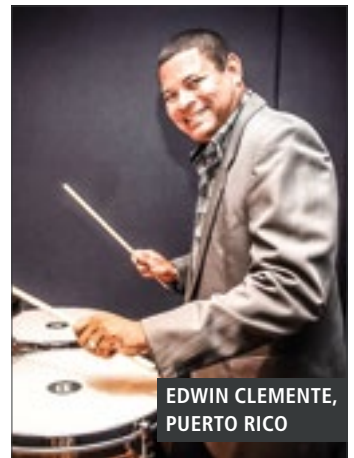

EDWIN CLEMENTE,
PUERTO RICO

8 CHIMES, 12 BARS
SIZE 12 bars, single row
MATERIAL Gold anodized aluminum alloy
FEATURES Produce a beautiful, high pitched sound
 Ideal for tasteful chime accents

9 STUDIO CHIMES, 27 BARS
SIZE 27 bars, single row
MATERIAL Gold anodized aluminum alloy
FEATURE Slightly thinner bars for a full, rich and delicate sound

10 CHIMES, 27 BARS
SIZE 27 bars, single row
MATERIAL Gold anodized aluminum alloy
FEATURES Produce a full sound with a wide tonal spectrum
 Ideal for smaller stages and club scenes

11 CHIMES, 33 BARS
SIZE 33 bars, single row
MATERIAL Gold anodized aluminum alloy
FEATURES Produce a very bright sound with a pronounced upper overtone spectrum
 Perfect for all live situations
INCLUDES Holder; Striker

12 CHIMES, 66 BARS
SIZE 66 bars, double row
MATERIAL Gold anodized aluminum alloy
FEATURES Produces a rich and full sound
 Cut through any band setting
INCLUDES Holder; Striker

13 ARTIST SERIES CHIMES LUIS CONTE
SIZE 60 bars, double row
MATERIAL Silver anodized aluminum alloy
FEATURES Produces a bright sound from the medium and low pitched bars
 Perfect for all studio situations
INCLUDES Holder; Striker
COLOUR Green

FRAME DRUMS



1 HAND DRUMS

SIZES **HD10:** 10"; **HD12:** 12"; **HD14:** 14"; **HD16:** 16"; **HD18:** 18"; **HD20:** 20"; **HD22:** 22"

MATERIALS Siam Oak (*Hevea brasiliensis* Muell.-Arg.)
AB: Hand selected goatskin head
AB-TF: True Feel synthetic head

COLOUR Antique Brown

2 TARS

SIZES **FD16:** 16", 2 1/2" deep
FD18: 18", 2 1/2" deep
FD20: 20", 2 1/2" deep
FD22: 22", 2 1/2" deep

MATERIALS Siam Oak (*Hevea brasiliensis* Muell.-Arg.)
T: Hand selected goatskin head
T-TF: True Feel synthetic head

FEATURE Internal tuning system

INCLUDES Hex key

COLOUR Antique Brown, matte

3 ARTISAN EDITION TARS (PATENTED)

SIZES **AE-FD14:** 14", 2 1/2" deep
AE-FD18: 18", 2 1/2" deep
AE-FD22: 22", 2 1/2" deep

MATERIALS Siam Oak (*Hevea brasiliensis* Muell.-Arg.)
Hand selected goatskin head

FEATURES Special designed bearing edge (DE, US patent); Internal tuning system

INCLUDES Hex key

COLOUR Walnut Brown, matte

4 SEA DRUMS

SIZES **FD16:** 16", 2 3/4" deep
FD18: 18", 2 3/4" deep
FD20: 20", 2 3/4" deep
FD22: 22", 2 3/4" deep

MATERIALS Siam Oak (*Hevea brasiliensis* Muell.-Arg.)
Transparent synthetic head and
SD: Hand selected goatskin head
SD-TF: True Feel synthetic head

FEATURES Steel balls inside; Sealable filling port

COLOUR Antique Brown, matte

5 MIZHARS

SIZES **FD12:** 12", 4" deep; **FD14:** 14", 4" deep; **FD18:** 18", 4" deep

MATERIALS Siam Oak (*Hevea brasiliensis* Muell.-Arg.)
T-D: Hand selected goatskin head
T-D-TF: True Feel synthetic head

FEATURES Deep shell construction for full sound development; Internal tuning system

INCLUDES Hex key

COLOUR Brown Burl, matte

6 ARTISAN EDITION MIZHARS (PATENTED)

SIZES **AE-FD14:** 14", 4" deep
AE-FD18: 18", 4" deep
AE-FD22: 22", 4" deep

MATERIALS Siam Oak (*Hevea brasiliensis* Muell.-Arg.)
Hand selected goatskin head

5 **HAND SELECTED GOATSKIN HEAD**

18" x 4" **FD18T-D**
14" x 4" **FD14T-D**
12" x 4" **FD12T-D**

TRUE FEEL SYNTHETIC HEADS

18" x 4" **FD18T-D-TF**
14" x 4" **FD14T-D-TF**
12" x 4" **FD12T-D-TF**

6

22" x 4" **AE-FD22T-D**
18" x 4" **AE-FD18T-D**
14" x 4" **AE-FD14T-D**

7 **HAND SELECTED GOATSKIN HEAD**

16" x 2 1/2" **FD16BE**
14" x 4" **FD14BE**
12" x 4" **FD12BE**

TRUE FEEL SYNTHETIC HEADS

16" x 2 1/2" **FD16BE-TF**
14" x 4" **FD14BE-TF**
12" x 4" **FD12BE-TF**

8 **METAL RINGS FOR SPECIAL EFFECTS**

20" x 2 1/2" **FD20D-TF**
20" x 2 1/2" **FD20D-WH**

9 **CROSS BAR**

18" x 4" **FD18BO**

10 **DAMPENING LAYER FOR LESS OVERTONES**

14" x 6" **FD14IBO**

11

7 1/2" **FD7KA**

13

Set, 4 pcs. **PL-SET**

12

15" **HOD15**
12 1/2" **HOD125**

FEATURES Special designed bearing edge (DE, US patent); Internal tuning system
INCLUDES Hex key
COLOUR Walnut Brown, matte

7 BENDIRS

SIZES **FD12:** 12", 4" deep; **FD14:** 14", 4" deep; **FD18:** 16", 2 1/2" deep
MATERIALS Siam Oak (*Hevea brasiliensis* Muell.-Arg.)
BE: Hand selected goatskin head
BE-TF: True Feel synthetic head
FEATURES Internal tuning system; Buzzing effect
INCLUDES Hex key
COLOUR Antique Brown, matte

8 DAFS

SIZE 20", 2 1/2" deep
MATERIALS Siam Oak (*Hevea brasiliensis* Muell.-Arg.)
FD20D-TF: True Feel synthetic head
FD20D-WH: Woven synthetic head

FEATURE Metal rings for special effects
COLOUR Antique Brown, matte

BODHRANS 9 10

MATERIALS Siam Oak (*Hevea brasiliensis* Muell.-Arg.)
INCLUDES Hand selected goatskin head
INCLUDES Hex key

9 CELTIC BODHRAN

SIZE 18", 4" deep
FEATURES Cross bar; Internal tuning system
COLOUR Antique Brown, matte

10 IRISH BODHRAN

SIZE 14", 6" deep
FEATURES Extra deep shell for full sound development; Dampening layer around rim for reduced overtones
COLOUR Brown Burl, matte

11 KANJIRA

SIZE 7 1/2", 2 1/4" deep
MATERIALS Siam Oak (*Hevea brasiliensis* Muell.-Arg.)
FEATURES Hand selected goatskin head
INCLUDES Many sound options; Set of 3 jingles
COLOUR Hex key
COLOUR Antique Brown, matte

12 NATIVE AMERICAN-STYLE HOOP DRUMS

SIZES **HOD125:** 12 1/2"; **HOD15:** 15"
MATERIALS Hand selected buffalo head
FEATURE Nylon lacing and grip
INCLUDES Warm and powerful sound
Leather padded wooden beater

13 PLENERA SET

SIZES 8" Quinto; 10" Seguidor; 12" Tumbador
MATERIALS ABS Plastic frames; Goatskin heads
FEATURE External mechanical lug tuning
INCLUDES Nylon Bag; Tuning Key

MINI & STANDARD DARBUKAS



1 MINI DARBUKAS

SIZE 4 1/4" diameter, 7 3/4" tall
MATERIALS Aluminum shell; All-weather synthetic head
FEATURES Fun to play and easy to carry; Great gift idea
HE-050: Plain shell
HE-051: Hand hammered shell
HE-052: Hand engraved shell
HE-053: Lacquered shell
INCLUDES Tuning key

2 COPPER DARBUKAS, HAND ENGRAVED

SIZES **HE-204:** 7 1/2" diameter, 14 3/4" tall
HE-205: 7 7/8" diameter, 15 1/2" tall
MATERIALS Copper shell; Natural rawhide
FEATURE Hand engraved shell
INCLUDES Tuning key

3 COPPER DARBUKAS, BRASS PLATED, HAND HAMMERED

SIZES **HE-214:** 7 1/2" diameter, 14 3/4" tall
HE-215: 7 7/8" diameter, 15 1/2" tall
MATERIALS Copper shell; Synthetic head
INCLUDES Tuning key

4 ALUMINUM DARBUKAS, HAND ENGRAVED

SIZES **HE-122:** 6 1/2" diameter, 12 3/4" tall
HE-124: 8" diameter, 14 1/2" tall
MATERIALS Aluminum shell; Synthetic head
INCLUDES Tuning key

5 ALUMINUM JINGLE DARBUKAS, HAND HAMMERED

SIZES **HE-314:** 8" diameter, 14 1/2" tall
HE-315: 8 1/4" diameter, 16" tall
MATERIALS Aluminum shell; Synthetic head
FEATURES Built-in jingles; Hand hammered shell
INCLUDES Tuning key

6 ALUMINUM DARBUKAS, HAND HAMMERED

SIZES **HE-110:** 5 1/3" diameter, 9 1/4" tall
HE-111: 5 7/8" diameter, 11" tall
HE-112: 6 1/2" diameter, 12 3/4" tall
HE-113: 7 1/4" diameter, 13 1/3" tall
HE-114: 8" diameter, 14 1/2" tall
MATERIALS Aluminum shell; Synthetic head
FEATURE Hand hammered shell
INCLUDES Tuning key

7 ALUMINUM DARBUKAS, PLAIN

SIZES **HE-100:** 5 1/3" diameter, 9 1/4" tall
HE-101: 5 7/8" diameter, 11" tall
HE-102: 6 1/2" diameter, 12 3/4" tall
HE-103: 7 1/4" diameter, 13 1/3" tall
HE-104: 8" diameter, 14 1/2" tall
MATERIALS Aluminum shell; Synthetic head
INCLUDES Tuning key

MINI, ARTISAN EDITION & STANDARD DOUMBEKS



8 NEW

8 3/4", white
HEAD-136

8 3/4", black
HEAD-137

8 3/4", clear
HEAD-138

9 NEW

White Pearl, 8 3/4"
AEDD1

White Pearl, 8 3/4"
AEDD2

Blue Pearl, 8 3/4"
AEDD3

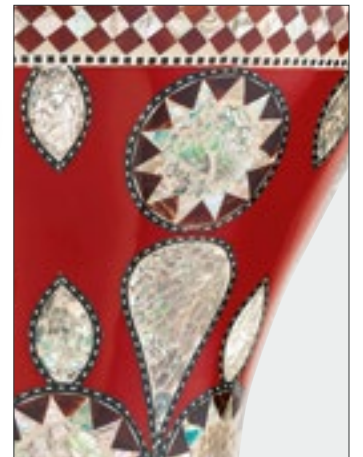

DARBUKAS & DOUMBEKS

10

4"
HE-1030

4"
HE-1018

11

10"
HE-3218

8 1/2"
HE-3018

6"
HE-2018

HAND ENGRAVED SHELL

8 1/2"
HE-3039

PAINTED FLORAL DESIGN

12

8 1/2"
HE-3012

HAND ENGRAVED SHELL

13

8 1/2"
HE-3030

HAND HAMMERED SHELL

14

10"
HE-3200

8 1/2"
HE-3000

6"
HE-2000

LEATHERETTE COVERED SHELL

8 ARTISAN EDITION EGYPT DOUMBEK HEADS

SIZE 8 3/4" diameter
MATERIAL Synthetic head
FEATURES Designed for the MEINL Artisan Edition Doumbeks
COLOURS **HEAD-136:** White
HEAD-137: Black
HEAD-138: Clear

9 ARTISAN EDITION EGYPT DOUMBEKS

SIZE 8 3/4" diameter, 17" tall
MATERIALS Aluminum shell; Synthetic head; Mother of pearl inlays
FEATURES Well balanced shape; Authentic Egyptian mosaic inlays; Produces outstanding dums and taks (teks)
INCLUDES Tuning key
DESIGNS **AEDD1:** Mosaic Royale
AEDD2: Mosaic Imperial
AEDD3: Mosaic Palace

10 MINI DOUMBEKS

SIZE 4" diameter, 7 1/2" tall
MATERIALS Aluminum shell; Synthetic head
FEATURES **HE-1018:** Hand engraved shell
HE-1030: Hand hammered shell
INCLUDES Tuning key

11 ALUMINUM DOUMBEKS, HAND ENGRAVED

SIZES **HE-2018:** 6" diameter, 12" tall (Soprano)
HE-3018, HE-3039: 8 1/2" diameter, 17 1/8" tall
HE-3218: 10" diameter, 18 1/4" tall (Bass)
MATERIALS Aluminum shell; Synthetic head
FEATURES **HE-2018:** High pitched articulate sounds
HE-3039: Painted floral design
HE-3218: Super deep tones
INCLUDES Tuning key

12 COPPER DOUMBEK, HAND ENGRAVED

SIZE 8 1/2" diameter, 17 1/8" tall
MATERIALS Copper shell; Synthetic head
INCLUDES Tuning key

13 ALUMINUM DOUMBEK, HAND HAMMERED

SIZE 8 1/2" diameter, 17 1/8" tall
MATERIALS Aluminum shell; Synthetic head
INCLUDES Tuning key

14 ALUMINUM DOUMBEKS

SIZES **HE-2000:** 6" diameter, 12" tall (Soprano)
HE-3000: 8 1/2" diameter, 17 1/8" tall
HE-3200: 10" diameter, 18 1/4" tall (Bass)
MATERIALS Aluminum shell (leatherette covered); Synthetic head
FEATURES **HE-2000:** High pitched articulate sounds
HE-3200: Super deep tones
INCLUDES Tuning key
COLOUR Black

RITUAL DRUMS

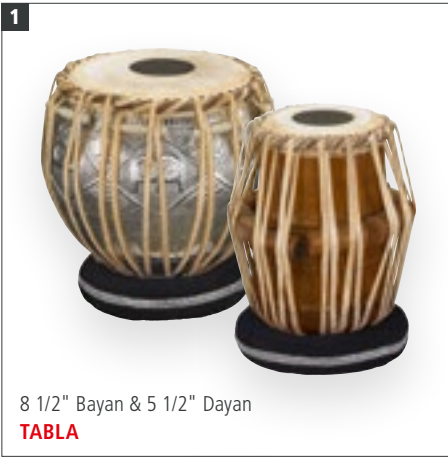

1

8 1/2" Bayan & 5 1/2" Dayan
TABLA



2

MADE BY MASTER CRAFTSMEN IN INDIA

9" Bayan & 5 1/2" Dayan
PRO-TABLA



3

ID10WH



4

ID3GO

RAWHIDE PLAYING SURFACE



5

ID4BKO

EXTRA FIBERGLASS PLAYING SURFACE



5

ID7RB



6

ID9BK/WH

THE FIBERGLASS LIQUID IBO DRUM IS FILLED WITH WATER

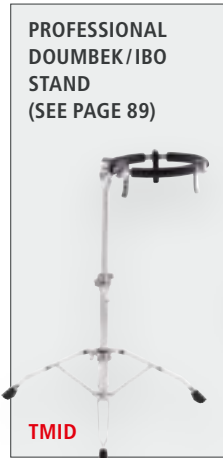

PROFESSIONAL DOUMBЕК/IBO STAND (SEE PAGE 89)

TMID



IBO HOLDER (SEE PAGE 92)

TMIH

1 TABLA SET

- SIZES** 5 1/2" Dayan
8 1/2" Bayan
- MATERIALS** Chrome plated copper with goatskin head
Mahogany with goatskin head
- FEATURES** Authentic tabla heads
Nylon straps for longer durability
- INCLUDES** Padded support rings; Tuning hammer

2 ARTISAN EDITION TABLA SET

- SIZES** 5 1/2" Dayan
9" Bayan
- MATERIALS** Copper with goatskin head
Mahogany with goatskin head
- FEATURES** Top quality goatskin tabla heads
Traditional tuning system with rawhide thongs
- INCLUDES** Tuning hammer and wooden tuning dowel; Ring pads; Protective head covers

3 QUINTO IBO DRUM

- SIZE** Small
- MATERIAL** Ceramic
- FEATURES** Full and rich sounds
Built-in microphone hole
- COLOUR** **WH:** White

4 FIBERGLASS TRI SOUND IBO DRUMS

- SIZE** Large
- MATERIAL** Premium fibreglass
- FEATURES** Built-in microphone hole
Resistant shell construction
ID3GO: Rawhide playing surface
ID4BKO: Extra fibreglass playing surface
- INCLUDES** Foam padded base
- COLOUR** **BKO:** Black Ornament
GO: Gold Ornament

5 CERAMIC IBO DRUM

- SIZE** Large
- MATERIAL** Ceramic
- FEATURES** Full and rich sounds
Built-in microphone hole
- INCLUDES** Foam padded base
- COLOUR** **RB:** Red/Brown

6 FIBERGLASS LIQUID IBO DRUM

- SIZE** Large
- MATERIAL** Premium fibreglass
- FEATURES** Special bottom, filled with water
Built-in microphone hole
Resistant shell construction
- INCLUDES** Foam padded base
- COLOUR** **BK/WH:** Black/White

7

6 3/4" & 12" Iya **BA3BK** 5 3/4" & 8 3/4" Itotele **BA2BK** 5 1/4" & 8" Okonkolo **BA1BK**

8

8" x 16" **ATD-L** 7" x 12" **ATD-M**

COMES WITH A CURVED WOODEN BEATER



9

TRUE SKIN BUFFALO HEADS

11" **MTA1SNT-M**

10

HEAVY-DUTY STAND CAN BE TILTED

8" & 9" **HCG89NT**

11

NEARLY UNBREAKABLE

SH-R **SHR-BR**

12

BE1R

7 BATAS

SIZES **BA1:** 5 1/4" & 8" Okonkolo
BA2: 5 3/4" & 8 3/4" Itotele
BA3: 6 3/4" & 12" Iya

MATERIALS Premium fiberglass
Hand selected buffalo heads

FEATURE Traditional TTR-Rims

INCLUDES Nylon strap; Tuning key

COLOUR **BK:** Black

8 AFRICAN WOOD TALKING DRUMS

SIZES **M:** 7" diameter, 12" tall
L: 8" diameter, 16" tall

PP ROPES **M:** 3 mm thickness, 23 runners
L: 3 mm thickness, 28 runners

MATERIALS Mahogany Wood (*Swietenia macrophylla*)
Hand selected goatskin heads

FEATURE Nylon tuning strap

INCLUDES Curved wooden beater

FINISH Brown/Black

9 TAMBORA

SIZE 11"

MATERIALS Siam Oak (*Hevea brasiliensis* Muell.-Arg.)
True Skin Buffalo Heads

FEATURE Black powder coated hardware

INCLUDES Nylon strap; Wooden beaters; Tuning key

COLOUR **SNT-M:** Super Natural

FINISH Matte

10 WOOD CONGUITAS

SIZES 8" & 9"

MATERIALS Siam Oak (*Hevea brasiliensis* Muell.-Arg.)
Hand selected buffalo heads

FEATURES 8 mm strong tuning lugs; Original MEINL style tuning brackets; Traditional rims; Black powder coated hardware

INCLUDES Height adjustable tilting double braced tripod stand; Tuning key; Wrench

COLOUR **NT:** Natural

FINISH High gloss

11 SHEKERES

SIZES **SH-R:** Medium
SHR-BR: Medium

MATERIAL Premium fiberglass

COLOURS **BR:** Brown
R: Red

12 BERIMBAU

MATERIAL Premium fiberglass

INCLUDES Small Caxixi; Metal plate; Wooden stick; Carrying bag

COLOUR **R:** Red

DIDGERIDOOS

1 COLOURFUL HAND-PAINTED ACCENTS HARKEN TO TRADITIONAL NATIVE AUSTRALIAN DESIGNS



47" **DDG1-BK** 47" **DDG1-BR** 47" **DDG1-R**

2



51" **SDDG1-BA** 51" **SDDG1-BK** S-Shape, 51" **SDDG2-BK**

3 TWO TELESCOPING SECTIONS



36"-62" **TSDDG1-BK**

1 WOOD DIDGERIDOOS

SIZE 47"
 MATERIAL Bamboo
 TUNING **DDG1-BK**: E
DDG1-BR: D#
DDG1-R: E
 COLOURS **BK**: Black
BR: Brown
R: Red

2 SYNTHETIC DIDGERIDOOS

SIZE 51"
 MATERIAL Lightweight synthetic
 TUNING **SDDG1-BA**: D
SDDG1-BK: D
SDDG2-BK: C#
 FEATURES **SDDG2-BK**
 "S" shaped body for bigger sounds
 Distinctive, full drone and harmonic overtones
 COLOURS **BA**: Bamboo
BK: Black

3 TROMBONE DIDGERIDOO

SIZE 36"-62"
 MATERIAL Premium fiberglass
 TUNING from: G#, G, F#, F, E, D#, D, C#, C
 FEATURE Two telescoping sections for variable pitch
 COLOUR **BK**: Black



60"
TSDDG2-BK



57"
PROFDDG1-BK



57"
PROSDDG1-BK



61"
SDDG1-SI



8 1/2" x 5"
DDG-BOX

SMALL IN SIZE BUT BIG IN SOUND



DDG-MP



4 SYNTHETIC SLIDE TRAVEL DIDGERIDOO

SIZE Portable: 24"; Playable: 60"
MATERIAL Lightweight synthetic
TUNING D
FEATURES Contractible body for easy travel
Distinctive, full drone and harmonic overtones
INCLUDES Bag
COLOUR **BK:** Black

5 PRO FIBERGLASS DIDGERIDOO

SIZE 57"
MATERIAL Premium fiberglass
TUNING D
COLOUR **BK:** Black

6 PRO SYNTHETIC DIDGERIDOO

SIZE 57"
MATERIAL Lightweight synthetic
TUNING D
COLOUR **BK:** Black

7 ARTIST SERIES DIDGERIDOO SIMON "SI" MULLUMBY

SIZE 61"
MATERIAL Premium fiberglass
TUNING F
COLOUR Grey

8 TRAVEL DIDGERIDOO (US PATENT)

SIZE 8 1/2" x 5"
MATERIAL Mahogany Wood (*Swietenia macrophylla*)
TUNING C
FEATURES Heat-branded logo
Compact size

9 DIDGERIDOO MOUTHPIECE

SIZE Inner diameter: 30 mm
Outer diameter: 60 mm
MATERIAL Antiseptic beeswax
FEATURES Easy mountable
100% pure beeswax
Fits perfect on our didgeridoos

RAINMAKER & RAINSTICKS

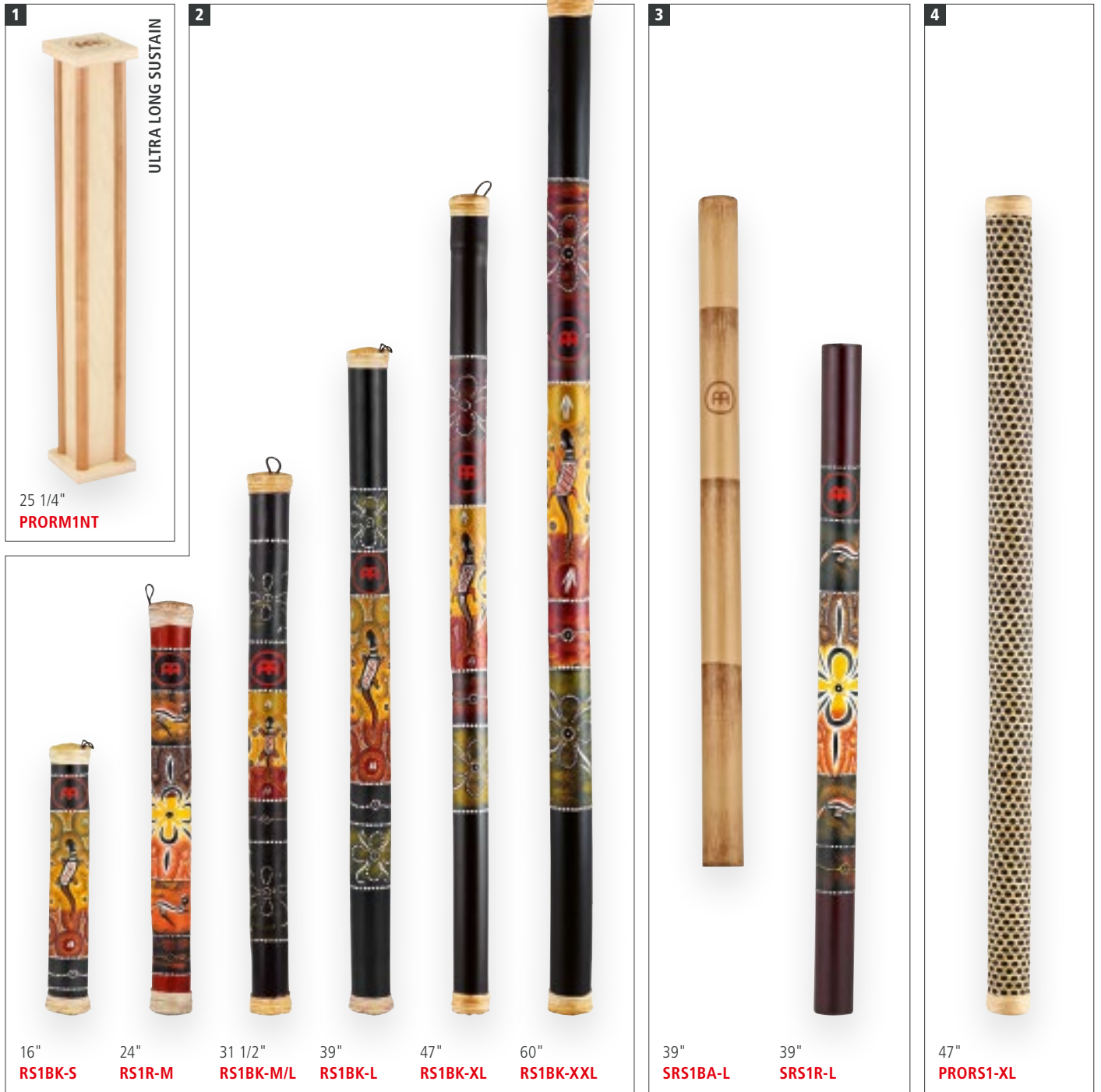

1 **ULTRA LONG SUSTAIN**
25 1/4"
PRORM1NT

2
16" **RS1BK-S**
24" **RS1R-M**
31 1/2" **RS1BK-M/L**
39" **RS1BK-L**
47" **RS1BK-XL**
60" **RS1BK-XXL**

3
39" **SRS1BA-L**
39" **SRS1R-L**

4
47" **PRORS1-XL**

1 PRO RAINMAKER
SIZE 3 3/4" W x 25 1/4" H x 3 3/4" D
MATERIAL Baltic Birch (*Betula pendula*)
FEATURES Ultra long sustain
 Authentic rain sound
 Natural birch wood construction
COLOUR **NT:** Natural

2 WOOD RAINSTICKS
SIZES **S:** 16"
M: 24"
M/L: 31 1/2"
L: 39"
XL: 47"
XXL: 60"
MATERIAL Bamboo
COLOURS **BK:** Black
R: Red

3 SYNTHETIC RAINSTICKS
SIZE **L:** 39"
MATERIAL Lightweight synthetic
COLOURS **BA:** Bamboo
R: Red

4 PRO RAINSTICK
SIZE **XL:** 47"
MATERIAL Rattan wrapped Bamboo
FEATURES Long susurraton
 Authentic rain sounds

PERCUSSION CYMBALS



RAINSTICKS & CYMBALS

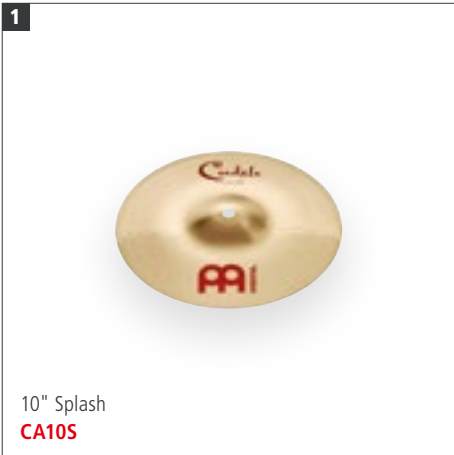

10" Splash
CA10S

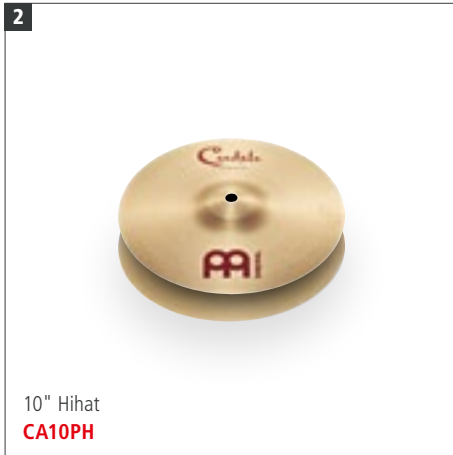

10" Hi-hat
CA10PH



14" Crash
CA14C



18" Timbales Crash-Ride
CA18CR



14" Jingle Bell
CA14PJB



16" Crash
CA16C



Magnetic Sustain Control
MCT

BASED ON BENNY GREB'S IDEA

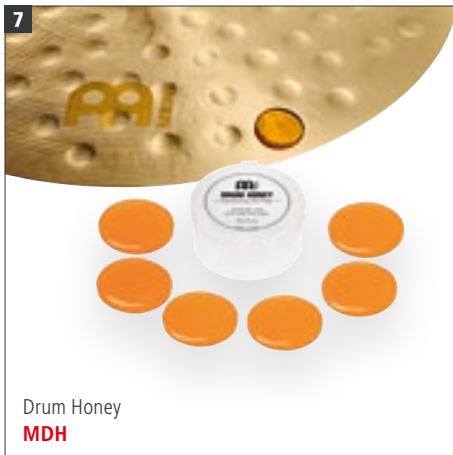

Drum Honey
MDH

NEW

A DROP OF HONEY MAKES YOUR DRUMS AND CYMBALS SOUND SWEET



Drum Honey Assortment
MDHA

1 PERCUSSION SPLASH

SIZE 10"
MATERIAL B20 Bronze
FEATURES Hand-hammered
Brilliant finish
Fast response and attack
Quick decay

2 PERCUSSION HIHAT

SIZE 10"
MATERIAL B20 Bronze
FEATURES Can be played by hand or with lighter sticks
Recommended for use with the MEINL Low Hat

3 PERCUSSION CRASHES

SIZES **CA14C:** 14"
CA16C: 16"
MATERIAL B20 Bronze

FEATURES Hand-hammered
Brilliant finish
Fast response and attack
Quick decay

4 TIMBALES CRASH-RIDE

SIZE 18"
MATERIAL B20 Bronze
FEATURES Hand-hammered
Brilliant finish
Cutting bell sound
Great crash sound

5 PERCUSSION JINGLE BELL

SIZE 14"
MATERIAL B8 Bronze
FEATURES Precisely hammered
Built-in jingles

6 MAGNETIC SUSTAIN CONTROL

CONTAINS 2 x Light dampening magnets (16 x 4 mm)
2 x Heavy dampening magnets (16 x 9 mm)
FEATURES Easily control the sustain and dampen the tone of your cymbals, cowbell, or other instruments
Simply adjust the effect by positioning the magnets on your instrument
INCLUDES Storage container

7 DRUM HONEY

CONTAINS **MDH:** 1 pack of Drum Honey (6 pcs.)
MDHA: 12 Drum Honeys (6 x small, 4 x medium, 2 x large)
FEATURES Transforms your drum sound into a warm and sweet tone with no effort
The gels can be removed and reused as needed
Washable and non-toxic

STICKS, BEATERS, BRUSHES, MALLETS & SCRAPERS



1 BASS BEAT CAJON BRUSH

SIZE 13" long
MATERIALS Polymer bristles
Foam rubber
FEATURES Straight polymer bristles for ultra-smooth precision; Soft foam rubber for full-bodied low notes; Two adjustable control rings; Flexible handle

2 CAJON MALLET COLLECTION

SIZES **MCM1, MCM4:** 11 3/4" long
MCM2: 12 1/4" long
MCM3: 15 1/2" long
MATERIALS Foam rubber
MCM1, MCM2, MCM3: Hard maple
MCM4: Aluminum
FEATURES Made in Germany
MCM1: Made out of the finest hand-selected maple; Small foam rubber head; Designed for softer playing
MCM2: Made out of the finest hand-selected maple; Extra thick foam rubber head
MCM3: Made out of the finest hand-selected maple; Foam rubber padding; Two different ends for contrasting sounds
MCM4: Integrated shaker effect in handle; Soft foam rubber head; Lightweight aluminum handle

3 TAMBORIM STICKS

MATERIAL Plastic
COLOURS **BK:** Black
R: Red

4 BODHRAN TIPPERS

MATERIAL Ash Wood
COLOUR Antique Brown

5 SAMBA STICKS

SIZES **SST1-S:** Stick, short version
SST1-R: Stick, medium version
SST1-L: Stick, long version
SST3-S: Triple stick, short version
SST3: Triple stick
SST7: Sevenfold stick
MATERIAL Plastic

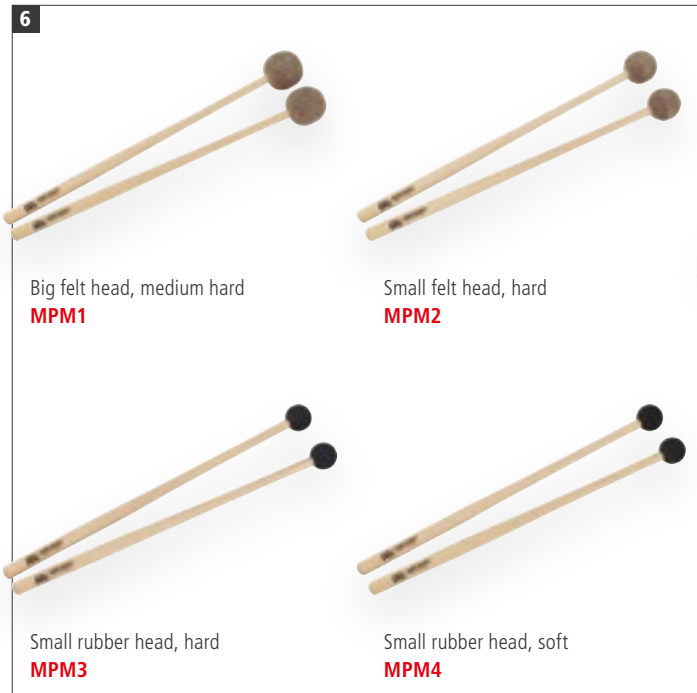

6 PERCUSSION MALLETS

SIZE 12 1/2" long
MATERIALS Hard maple
MPM1: Big felt head, medium hard
MPM2: Small felt head, hard
MPM3: Small rubber head, hard
MPM4: Small rubber head, soft
FEATURES Made out of the finest hand-selected maple; Great for woodblocks and plastic percussion blocks; Made in Germany

7 COWBELL BEATERS

MATERIALS **COW1, COW2:** Siam Oak (*Hevea brasiliensis* Muell.-Arg.)
COW3: ABS plastic
FEATURES Ribbed grip; Durable construction

8 HANDMATE

MATERIAL Steel construction with a wooden ball
FEATURE Fully adjustable

9 SURDO BEATER HOLDER

MATERIAL Leather
COLOUR Black

10 SAMBA BEATERS

SIZES **SB1:** 15" long
SB2, SB3, SB4, SB5, SB6: 16" long
MATERIALS **SB1:** Aluminum stick with 2" felt beater
SB2: Wood stick with 2" felt beater
SB3: Wood stick with 2 1/2" felt beater
SB4: Wood stick with 2" leather beater
SB5: Wood stick with 3" bushy felt beater
SB6: Wood stick

11 TALKING DRUM BEATER

MATERIAL Mahogany Wood

12 GÜIRA SCRAPERS

MATERIALS Steel rods
MGS1: Ergonomic wooden grip
MGS2: Sanded ABS grip

STANDS

1



Black powder coated



Chrome plated



Gold tone

Black powder coated

For Marathon® Classic Series
For Marathon® Designer Series
For Luis Conte Artist Series
ST-MCC11BK: 11"
ST-MCC1134BK: 11 3/4"
ST-MCC1212BK: 12 1/2"

Chrome plated

For Marathon® Exclusive Series
ST-MEC11CH: 11"
ST-MEC1134CH: 11 3/4"
ST-MEC1212CH: 12 1/2"
For Professional Series
For Fibercraft Series
ST-MP11CH: 11"
ST-MP1134CH: 11 3/4"
ST-MP1212CH: 12 1/2"
For Floatune Series
ST-FL10CH: 10"
ST-FL11CH: 11"
ST-FL12CH: 12"
ST-FL13CH: 13"
For Woodcraft Series
ST-WC11CH: 11"
ST-WC1134CH: 11 3/4"
ST-WC1212CH: 12 1/2"

Gold tone

For Marathon® Exclusive Series
ST-MEC11G: 11"
ST-MEC1134G: 11 3/4"
ST-MEC1212G: 12 1/2"
For Mongo Santamaria Artist Series
ST-MSA11G: 11"
ST-MSA1134G: 11 3/4"
ST-MSA1212G: 12 1/2"

**QUICK AND EASY HEIGHT
ADJUSTABILITY (DE PATENT)**

2

EASY HEIGHT EXTENSION

Black powder coated
ST-HEBK

Chrome plated
ST-HECH

Gold tone
ST-HEG



3



MIN. 43"
MAX. 52 3/4"

For Headliner® congas
HDSTAND

For MCC congas
TMDS

4



For HDSTAND and TMDS
THBM

**EASY
MOUNTABLE**

6



Chrome plated
MCH-CH

Gold tone
MCH-G

FOR ANY CONGA

5



Chrome plated
TMPDS

1 STEELY II CONGA STANDS (PATENTED)

MATERIAL Steel
FEATURES Metal spike attachment on each leg
L-shaped legs (DE, TH, US patent)
U-shaped notch for quick set up and breakdown (US patent)
Ergonomic arched rubber bracing for more stability (CN, DE, TH, US patent)
Notches for quick height adjustability (DE patent)
INCLUDES Hex key

2 STEELY II CONGA STAND HEIGHT EXPANDER SETS (DE PATENT)

MATERIAL Steel
FEATURE Easy and effective height extension
INCLUDES Mounting screws; Hex key
FINISHES **BK:** Black powder coated
CH: Chrome plated
G: Gold tone

3 CONGA DOUBLE STANDS

MATERIAL Steel
FEATURES Height adjustable
Double braced tripod legs
INCLUDES Hex key; Memory locks; Brackets; Set of screws, nuts, and washers; Mounting instructions

4 BONGO MOUNT

MATERIAL Chrome plated steel
FEATURES Easy mountable on our conga double stands HDSTAND and TMDS
Holds your bongo in place
Adjustable angle

5 PROFESSIONAL CONGA DOUBLE STAND WITH WHEELS

MATERIAL Chrome plated steel

FEATURES Height adjustable
Heavy construction
Double braced tripod legs
Lockable high-quality wheels
Padded separators for adjustable angle
Mounting instructions
INCLUDES Two mounting brackets

6 CONGA HANDLES

MATERIAL Steel
FEATURES Simple and safe add-on to help transport congas
Easily mountable with instructional guide
Fits any common conga
Leaves sound unaffected
INCLUDES Mounting screws and washers; Mounting instructions
FINISHES **CH:** Chrome plated
G: Gold tone

7 STURDY LOCKABLE WHEELS MAKE IT EASY TO MOVE THE STAND INTO POSITION



Chrome plated
TMPC

8 THE LIGHTWEIGHT STAND CAN BE FOLDED TO A COMPACT UNIT WHICH REQUIRES LITTLE SPACE



Chrome plated
TMC-CH

COMPATIBLE FOR ALL SIZES!



MIN. 34 1/2"
MAX. 50"

Black powder coated
THBS-BK

Chrome plated
THBS

AN INNOVATIVE BRACKET DESIGN ENABLES QUICK SET UP (PATENTED)

10 PADDED T-SHAPED TUBE FOR MORE STABILITY



MIN. 31 1/2"
MAX. 52 3/4"

Chrome plated
TMB

11 A STABLE METAL CLAMP HOLDS THE ENTIRE UNIT IN PLACE



MIN. 12 1/4"
MAX. 20"

Chrome plated
TMB-S

LOW HEIGHT FOR SEATED PLAYERS

12 PERFECT HEIGHT FOR CAJON PLAYERS



MIN. 22 3/4"
MAX. 29 1/2"

Black powder coated
THBS-S-BK

13 DIFFERENT RODS FOR ALL NEEDS



MIN. 31 1/2"
MAX. 52 1/2"

Chrome plated
TMPS

7 PROFESSIONAL CONGA STAND WITH WHEELS

- MATERIAL** Chrome plated steel
FEATURES Adjustable padded stops fit any conga size
Height adjustable legs
Lockable wheels

- FEATURES** Quick set up
Easy handling
Reliable placement
Double braced tripod stand
Fits all common bongos
- INCLUDES** Wrench
- FINISHES** **THBS:** Chrome plated
THBS-BK: Black powder coated

- FEATURES** Seated playing position possible
Padded T-shaped tube
Fully height and angle adjustable
Double braced tripod legs
Fits all common bongos
- INCLUDES** Hex key; Memory lock

8 PROFESSIONAL CONGA STAND

- MATERIAL** Chrome plated steel
FEATURES Unique design (DE patent)
Rubber padded crossbeams
Fully height adjustable
Folds up to a compact unit
- INCLUDES** Hex key; Memory locks

10 PROFESSIONAL BONGO STAND

- MATERIAL** Chrome plated steel
FEATURES Padded T-shaped tube
Fully height and angle adjustable
Double braced tripod legs
Fits all common bongos
- INCLUDES** Hex key; Memory locks

12 CAJON HEIGHT BONGO STAND

- MATERIAL** Black powder coated steel
FEATURES Quick set up
Easy handling
Perfect height for cajon players
Fits all common bongos

9 HEADLINER® SERIES BONGO STANDS (CN, DE, US PATENT)

- MATERIAL** Steel

11 PROFESSIONAL BONGO STAND FOR SEATED PLAYERS

- MATERIAL** Chrome plated steel

13 PERCUSSION STAND

- MATERIAL** Chrome plated steel
FEATURES Height adjustable
Double braced tripod legs
- INCLUDES** Hex key; Memory locks; 2 straight rods; 2 angled rods; 2 Z-shaped rods

STANDS

1 COLLAPSIBLE DESIGN



Black powder coated
STDJST-BK

2



QUICK AND EASY HEIGHT ADJUSTABILITY (DE PATENT)

Chrome plated
ST-DJEMBE

3 LENGTH ADJUSTABLE FOR VARIOUS DJEMBE SIZES



MIN. 23 1/2"
MAX. 37 3/4"

Chrome plated
TMD

4 FITS ALL CAJON SIZES



MIN. 26"
MAX. 40 1/2"

Black powder coated
TMCAJ

CAJON MICROPHONE STAND
(SEE PAGE 04)



CMS

CAJON DRUM SET STANDS
(SEE PAGE 16)



MIN. 27"
MAX. 42"

MIN. 25"
MAX. 45"

MIN. 22"
MAX. 37"

CJS **CCS** **CAS**

5



MIN. 22"
MAX. 37"

Black powder coated
CPTS

1 TRAVEL DJEMBE STAND
MATERIAL Black powder coated steel
FEATURES Collapsible design
 Lightweight construction

2 STEELY II DJEMBE STAND (PATENTED)
MATERIAL Chrome plated steel
FEATURES Metal spike attached to each leg
 L-shaped legs (DE, TH, US patent)
 U-shaped notch for quick set up and breakdown (US patent)
 Ergonomic arched rubber bracing for more stability (CN, DE, US patent)
 Notches for quick height adjustability (DE patent)
 Adapts to different djembe sizes
INCLUDES Hex key, 3 spacers

3 PROFESSIONAL DJEMBE STAND
MATERIAL Chrome plated steel
FEATURES Rubber padded hooks
 Fully height and angle adjustable
 Double braced tripod legs
INCLUDES Hex key; Memory lock

4 PROFESSIONAL CAJON STAND
MATERIAL Steel
FEATURES Quick set up
 Fully height and angle adjustable
 Double braced tripod stand
 Fits all cajon sizes

5 CAJON PICKUP TAPS STAND
MATERIAL Black powder coated aluminum
FEATURES Designed to mount the MEINL Cajon Pickup Tom and Snare Taps
 Low-key stage footprint
 L-Shaped 3/8" rod
 Foldable legs, height adjustable

6 LOW HAT
MATERIAL Chrome plated steel
FEATURES Special low height
 Made just for cajon players

6 SPECIAL LOW HEIGHT



MIN. 29 1/2"
MAX. 38"

Chrome plated
MLH

7



MIN. 34"
MAX. 57"

Chrome plated
TMT

8



MIN. 34"
MAX. 57"

Chrome plated
TMPT

9 THREE-ARM BASKET HOLDS THE HAND-BALE SECURELY



Chrome plated
TMTS

10



Black powder coated
DDG-STAND

11 NEW



Black powder coated
TMDDGS

12



MIN. 30 3/4"
MAX. 67"

Chrome plated
TMCH

13



MIN. 31 3/4"
MAX. 50 3/4"

Chrome plated
TMID

7 TIMBALE STAND

- MATERIAL** Chrome plated steel
- FEATURES** Double braced tripod base
Height and angle adjustable
Standard mounting rod for auxiliary percussion
- INCLUDES** Accessory pouch; L-shaped tuning key; Tune Up Oil

8 PROFESSIONAL TIMBALE STAND

- MATERIAL** Chrome plated steel
- FEATURES** Heavy-duty double braced tripod base
Height and angle adjustable
Standard mounting rod for auxiliary percussion
- INCLUDES** Accessory pouch; L-shaped tuning key; Tune Up Oil

9 HAND-BALE STAND

- MATERIAL** Chrome plated steel
- FEATURES** Quick set up
Rubber-tipped three arm basket
Easy handling
Double braced tripod stand

10 DIDGERIDOO STAND

- MATERIAL** Black powder coated aluminum
- FEATURES** Steady support for your didgeridoo
Stable tripod base
Soft padding
Rubber yoke for added protection
- FINISH** Black

11 PROFESSIONAL DIDGERIDOO STAND

- MATERIAL** Black powder coated aluminum
- FEATURES** Dual leg base and strong aluminum construction
Protective rubber yoke and soft padding
Height and angle adjustable
- FINISH** Black

12 CHIMES STAND

- MATERIAL** Chrome plated steel
- FEATURES** Full angle and height adjustability
Secure angle clamps
Telescoping stem

13 PROFESSIONAL DOUMBЕК/IBO STAND

- MATERIAL** Chrome plated steel
- FEATURES** Foam padded ring
Fully height and angle adjustable
Double braced tripod legs
- INCLUDES** Hex key; Memory lock

TABLES & CAJON RACK

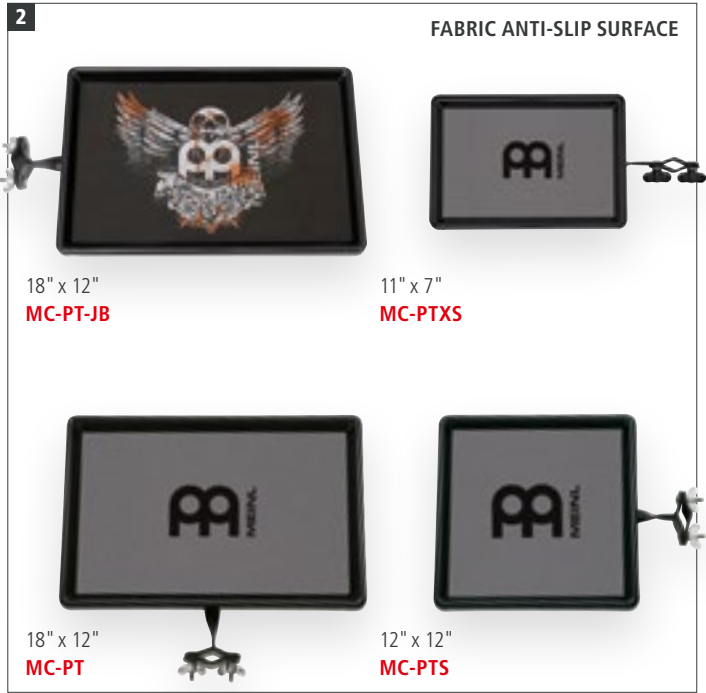

1 LAPTOP TABLE STAND

- SIZE** 20" x 12 1/2"
- MATERIAL** Perforated metal plate
- FEATURES** Holds laptops up to 17"
Stoppers and hook and loop fastener to secure the laptop
Holder for headphones
Cord strain relief

2 PERCUSSION TABLES

- SIZES** **MC-PT:** 18" x 12"
MC-PT-JB: 18" x 12"
MC-PTS: 12" x 12"
MC-PTXS: 11" x 7"
- MATERIALS** **MC-PT, MC-PT-JB, MC-PTS:** Premium fiberglass
MC-PTXS: Plastic
- FEATURES** Fabric anti-slip surface; Adjustable angle;
Strong mounting clamp
MC-PT-JB: Jawbreaker motif

3 PERCUSSION WORKSTATION

- MATERIAL** Black powder coated steel
- FEATURES** Fully height adjustable
Angle adjustable top bar
Heavy-duty construction
Infinitely expandable
Fabric anti-slip surfaces
Colour doesn't interfere with stage lighting
- INCLUDES** 1 x Padded fiberglass percussion table, 22" x 24"
2 x Padded fiberglass percussion tables, 18" x 12" (attachable)
1 x Vertical bar, 30"
2 x Vertical bars, 15" (attachable)
4 x Straight rods with hook
3 x Angled rods with hook
1 x Z-shaped rod with hook

4 PERCUSSION TABLE STAND

- SIZE** 16" x 22"
- MATERIALS** Table: Premium fiberglass
Stand: Chrome plated steel
- FEATURES** Fabric anti-slip surface
Fully height adjustable
Double braced tripod legs
- INCLUDES** Hex key; Memory lock

5 ERGO TABLE

- SIZE** 20" x 34"
- MATERIALS** Table: Premium fiberglass
Stand: Chrome plated steel
- FEATURES** Fabric anti-slip surface
Padded edge
Fully height adjustable
Ergonomic shape for more efficiency
Double braced tripod legs
- INCLUDES** Hex key; Memory lock

4 ALL MEINL TRIPOD STANDS ARE EQUIPPED WITH MEMORY AND QUICK LOCKS

16" x 22"
TMPTS

MIN. 30"
MAX. 46 3/4"

5 ERGONOMIC SHAPE FOR MORE EFFICIENCY

20" x 34"
TMPETS

MIN. 30"
MAX. 46 3/4"

6

CLAMP WITH STRAIGHT ROD

CLAMP WITH Z-SHAPED ROD

10" x 16"
PADDED TABLE

Black powder coated
TMCR

7

CR-CLAMP1 **CR-CLAMP2** **CR-CLAMP3**

8

CR-BAR T-CONNECTOR FOR VARIABLE MOUNTING POSSIBILITIES

9

MC-R1-H **MC-R2-H** **MC-R3-H**















6 CAJON RACK
SIZE 28 1/2" W x 46" H x 25 1/4" D
MATERIAL Black powder coated aluminum
FEATURES Perfect height for seated cajon players
 Keep necessary percussion accessories close by
 Mount tambourines and other small drums
 Percussion table for shakers and other small instruments
INCLUDES Padded table, 10" x 16"
 Clamp with straight rod
 Clamp with z-shaped rod

7 CAJON RACK MOUNTING CLAMPS
MATERIALS Chrome plated steel
 Black powder coated die cast steel
FEATURES Clamp and rod for added accessories to the MEINL Cajon Rack
 Rod fits any common tambourine, block or cowbell
 Strong mounting clamp
INCLUDES Mounting bracket
 Z-shaped rod (CR-CLAMP1)
 Straight rod (CR-CLAMP2)
 L-shaped rod (CR-CLAMP3)

8 BAR FOR CAJON RACK
SIZE 11" long
MATERIAL Black powder coated aluminum
FEATURES T-connector for variable mounting possibilities
 Place anywhere on the MEINL Cajon Rack
 Great for expanding your percussion assortment
INCLUDES Mounting bracket

9 RODS WITH HOOK
SHAPES **MC-R1-H:** Straight rod
MC-R2-H: Angled rod
MC-R3-H: Z-shaped rod
MATERIAL Chrome plated steel
FEATURES Knurled surface
 Hook

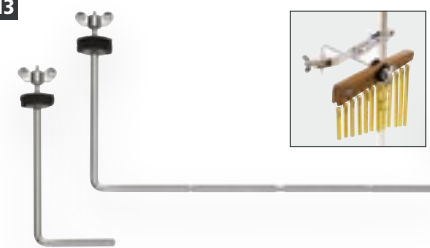
HARDWARE

<p>1 HOLDS TAMBOURINES AND SHAKERS</p>  <p>Mini Percussion Rack MC-SHTA</p>	<p>2 PADDLED SURFACE</p>  <p>Tambourine Holder MC-TH</p>	<p>3</p> <p>MIN. 1" MAX. 6"</p>  <p>Shaker Holder MC-SH</p>	
<p>4 NEW</p>  <p>A-Go-Go Bell Holder STBAGH</p>	<p>5</p> <p>MIN. 2 1/2" MAX. 3 3/4"</p>  <p>Güiro Holder MC-GU</p>	<p>6</p>  <p>Wood Block Holder MWBH1</p>	<p>7 FOR TURBO CABASA, MEDIUM</p>  <p>Cabasa Holder MC-CA</p>
<p>8 NEW</p>  <p>Standard Frame Drum Holder MC-STFDH</p>	<p>9</p>  <p>Frame Drum Holder MC-FDH</p>	<p>10 ENABLES YOU TO PLAY THE IBO WITH BOTH HANDS ON A TABLE</p>  <p>Ibo Holder TMIH</p>	<p>11</p>  <p>Triangle Holder MC-TRI</p>
<p>12</p>  <p>Triangle Clamp CLAMP-TRI</p>	<p>13</p>  <p>Chimes Holders MC-CH MC-CHL</p>	<p>14</p>  <p>Drumstick Holders MC-DSH MC-DSH-JB</p>	

1 MINI PERCUSSION RACK

MATERIALS Black powder coated steel
Foam rubber

FEATURES Holds tambourines and shakers; Clamps on any common mic or percussion stand; Perfect solution for keeping percussion pieces close by

COLOUR Black

2 TAMBOURINE HOLDER

MATERIAL Chrome plated steel

FEATURES Rubber pads; Padded surface

3 SHAKER HOLDER

MATERIAL Chrome plated steel

FEATURES Rubber pads; Length adjustable

4 A-GO-GO BELL HOLDER

MATERIAL Chrome plated steel

FEATURE Holds any A-Go-Go Bell in place

5 GÜIRO HOLDER

MATERIAL Chrome plated steel

FEATURE Rubber pads

6 WOOD BLOCK HOLDER

MATERIAL Chrome plated steel

7 CABASA HOLDER

MATERIAL Chrome plated steel

FEATURES Strong mounting clamp; Padded surface

8 STANDARD FRAME DRUM HOLDER

MATERIAL Chrome plated steel

FEATURE Perfect for frame drums or traditional wood tambourines

9 FRAME DRUM HOLDER

MATERIALS Chrome plated steel
Anodized aluminum

FEATURE Fully adjustable for any frame drum size

10 IBO HOLDER

MATERIAL Black powder coated steel

FEATURE Foam padded base

INCLUDES Hex key

11 TRIANGLE HOLDER

MATERIAL Chrome plated steel

FEATURES Knurled surface; Nylon cord

12 TRIANGLE CLAMP

MATERIAL Chrome plated steel

FEATURES Holds any triangle in place; Easy mountable

13 CHIMES HOLDERS

SIZES **MC-CH**: Regular
MC-CHL: Large

MATERIAL Chrome plated steel

FEATURES Knurled surface; Foam washer



Bass Drum
Cowbell Holders
MC-STBD **MC-BD**



Pedal Mount
PM-1



Pedal Mount
for Cymbals
PM-2

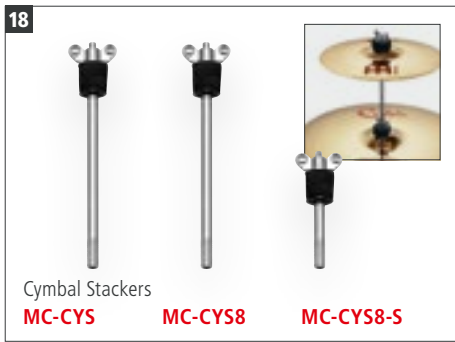

Cymbal Stackers
MC-CYS **MC-CYS8** **MC-CYS8-S**

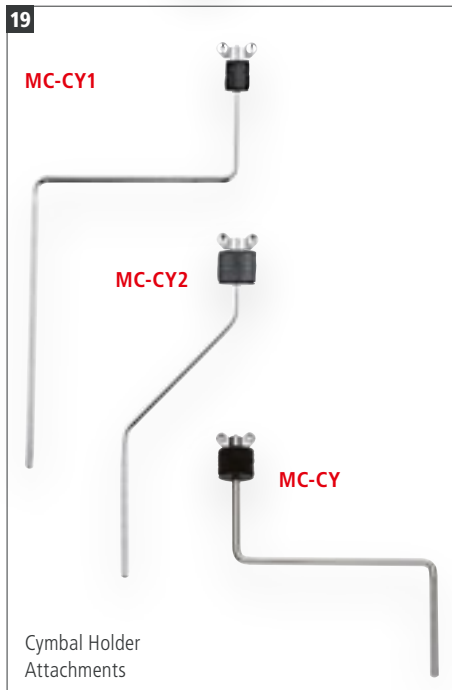

Cymbal Holder
Attachments



X-Hat Auxiliary
Hihat Arm
MXH



Cymbal
Attachment
MCA



X-Hat Cymbal
Stand Adapter
MXHA

14 DRUMSTICK HOLDERS

MATERIALS Chrome plated steel
Black textile pouch
FEATURE Strong mounting clamp
FINISHES **MC-DSH:** MEINL
MC-DSH-JB: Jawbreaker motif

15 BASS DRUM COWBELL HOLDERS

MATERIALS **MC-BD:** Chrome plated steel
MC-STBD: Black powder coated steel
FEATURES Rubber pads
MC-BD: Fully adjustable
INCLUDES **MC-BD:** L-shaped rod

16 PEDAL MOUNT

MATERIAL Black powder coated steel
FEATURES Height adjustable legs; Metal spikes; Fits on all common bass drum pedals and firmly holds cowbells, blocks, or tambourines
INCLUDES 2 differently sized L-rods

17 PEDAL MOUNT FOR CYMBALS

MATERIAL Black powder coated steel
FEATURES For foot activated cymbal crashes; Fits any common bass drum pedal; Holds cymbals ranging from 16" to 22"
INCLUDES Cymbal arm

18 CYMBAL STACKERS

SIZES **MC-CYS:** Ø 6 mm, long
MC-CYS8: Ø 8 mm, long
MC-CYS8-S: Ø 8 mm, short
MATERIAL Chrome plated steel
FEATURE Felt washers

19 CYMBAL HOLDER ATTACHMENTS

MATERIAL Chrome plated steel
FEATURES Knurled surface; Felt washers; For splashes or small crashes; Easy placement on a drumkit, cajon set or percussion rig

MC-CY: Z-shaped 3/8" rod
MC-CY1: S-shaped 3/8" rod
MC-CY2: Z-shaped 3/8" rod with extra-long knurled end

20 CYMBAL ATTACHMENT

MATERIAL Chrome plated steel
FEATURES Multi-clamp; Cymbal boom arm

21 X-HAT AUXILIARY HIHAT ARM

MATERIAL Chrome plated steel
FEATURES Easy to attach and position at any height or angle; Finely adjust the degree of tension on the cymbals

22 X-HAT CYMBAL STAND ADAPTER

MATERIAL Chrome plated steel
FEATURES Turn any cymbal stand into an X-Hat stand; Fits 8 mm threaded cymbal stand posts; Use with any size hihat or stack

HARDWARE

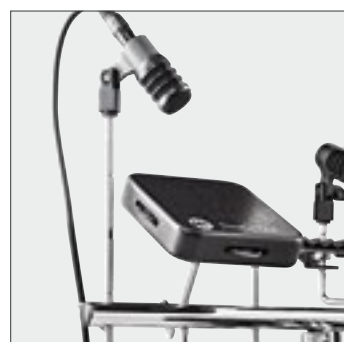
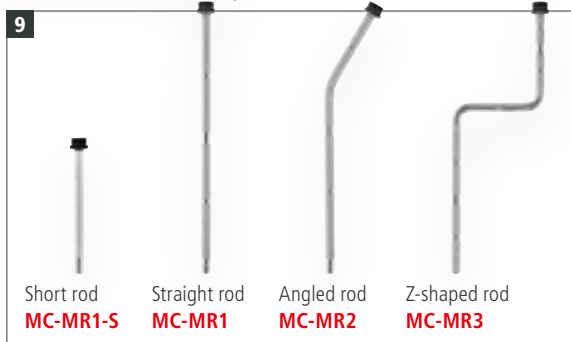
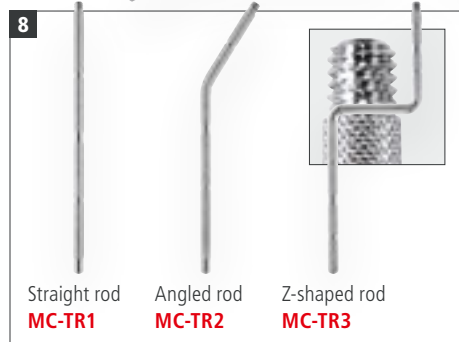
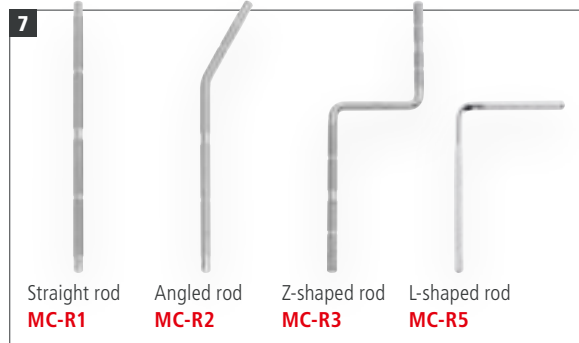
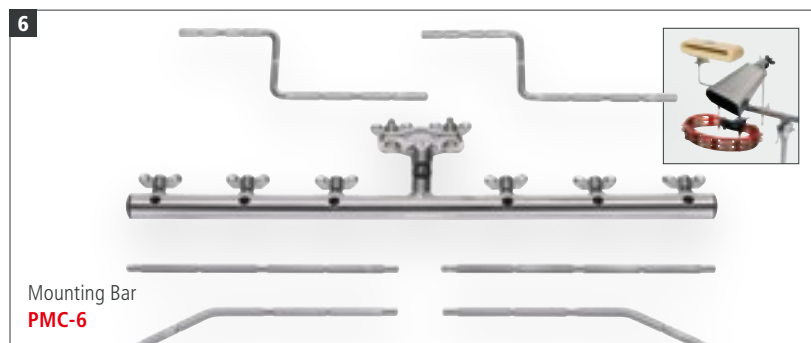
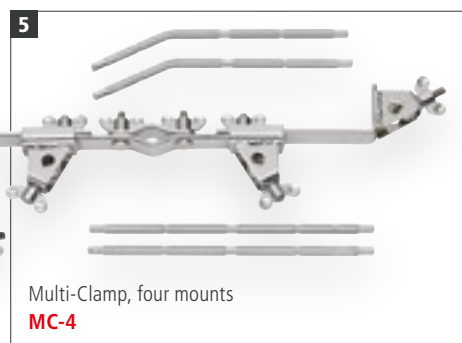
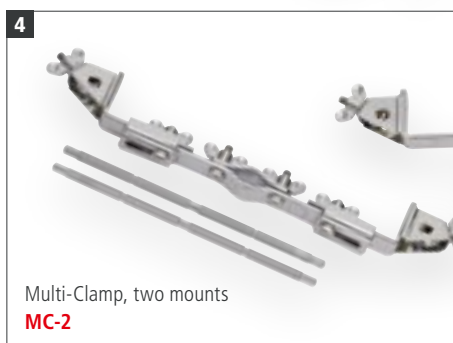
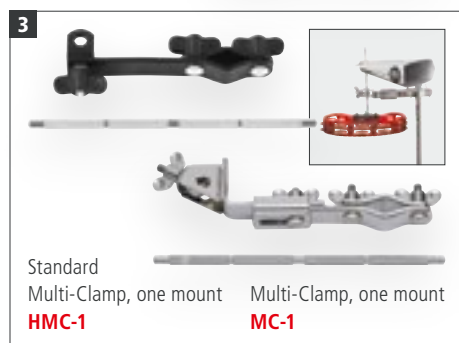
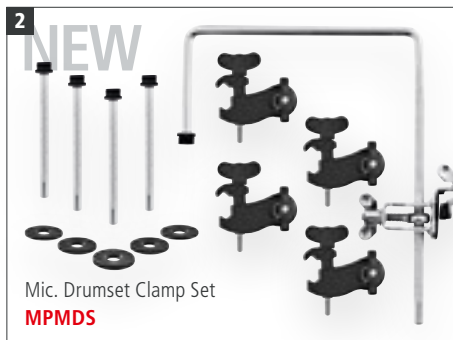

1 MICROPHONE CYMBAL CLAMP SET

CONTAINS 3 x Standard Multi-Clamp (HMC-1); 3 x Short Rod With Threaded Microphone Connector (MC-MR1-S); 1 x Microphone Rod Counter Nuts (MRCN5)

2 MICROPHONE DRUMSET CLAMP SET

CONTAINS 1 x Bass Drum Microphone Clamp (MC-MRBD); 4 x Rimclamp (RIMCLAMP-2); 4 x Short Rod With Threaded Microphone Connector (MC-MR1-S); 1 x Microphone Rod Counter Nuts (MRCN5)

3 MULTI-CLAMPS, ONE MOUNT

MATERIALS **HMC-1:** Black powder coated steel
MC-1: Chrome plated steel
FEATURES Strong mounting clamp
MC-1: Length adjustable
INCLUDES Straight rod

4 MULTI-CLAMP, TWO MOUNTS

MATERIAL Chrome plated steel
FEATURES Length adjustable; Strong mounting clamp
INCLUDES 2 straight rods

5 MULTI-CLAMP, FOUR MOUNTS

MATERIAL Chrome plated steel
FEATURES Length adjustable; Strong mounting clamp
INCLUDES 2 straight and 2 angled rods

6 MOUNTING BAR

MATERIAL Chrome plated steel
INCLUDES 2 straight, 2 angled and 2 z-shaped rods

7 RODS

MATERIAL Chrome plated steel
FEATURES Knurled surface; Available as a straight, angled, z-shaped, or l-shaped rod

8 THREADED PERCUSSION RODS

MATERIAL Chrome plated steel
FEATURES Threaded tip to mount any standard 3/8" threaded percussion instrument

9 RODS WITH THREADED MICROPHONE CONNECTOR

MATERIAL Chrome plated steel
FEATURES 3/8" diameter rod with threaded end; Designed to attach microphones; Use with the MEINL Rim Clamp; Available as a short, straight, angled, or z-shaped rod
MC-MR1-S: Perfect for mic'ing toms, snares or congas
INCLUDES Microphone screw adapter

10 BASS DRUM MICROPHONE CLAMP

MATERIAL Chrome plated steel
FEATURE U-shape 3/8" diameter rod with threaded end to attach a microphone



Bass Drum Microphone Clamp
MC-MRBD



Set, 5 pcs.
Microphone Rod Counter Nuts
MRCN5



Flexible Microphone Gooseneck
FMG



MICROPHONE CAJON CLAMP
(SEE PAGE 04)

MPMCC



Microphone Adapter
TMMA



Clamp
CLAMP

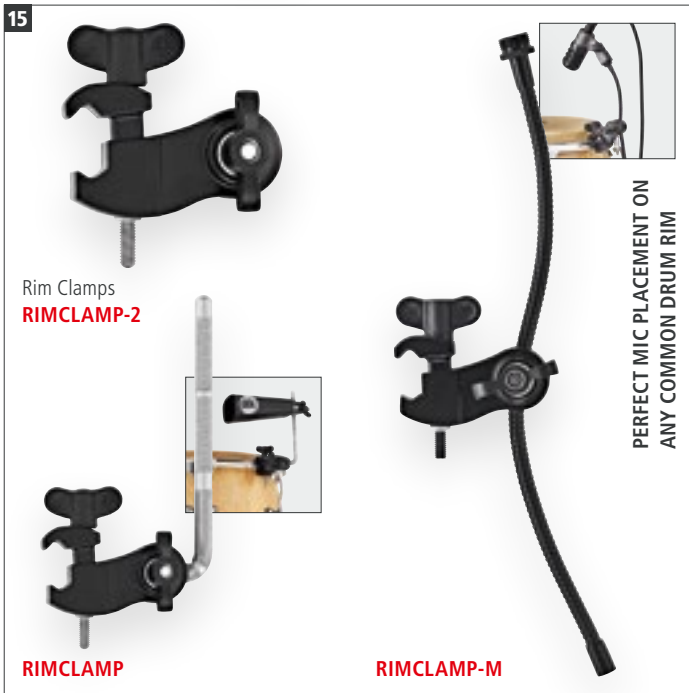

Rim Clamps
RIMCLAMP-2

RIMCLAMP

RIMCLAMP-M

PERFECT MIC PLACEMENT ON ANY COMMON DRUM RIM



Professional Multi-Clamps
TMPMC

TMPMC-R

TMPMC-G

STRONG CLAMP SECURES TO ANY DRUM RIM

11 MICROPHONE ROD COUNTER NUTS

MATERIAL Black powder coated steel
FEATURES Set of 5 counter nuts; Securely lock your microphone attachments; Use with MEINL Microphone rods with threaded connection (sold separately)

12 FLEXIBLE MICROPHONE GOOSENECK

SIZE 12.8" (32.5 cm)
MATERIAL Metal
FEATURES Optimal microphone placement; No additional stand required; Fits in the MEINL Rim Clamp; 3/8" and 5/8" threads

13 MICROPHONE ADAPTER

MATERIAL Chrome plated steel
FEATURES Turns your cymbal stand into a microphone stand; 8 mm threaded attachment
INCLUDES 5/8" male to 3/8" mic screw adapter

14 CLAMP

MATERIAL Chrome plated steel
FEATURE Compact and solid design

15 RIM CLAMPS

MATERIALS Black powder coated steel
RIMCLAMP: Chrome plated steel (L-shaped rod)
RIMCLAMP-M: Metal (Gooseneck)
FEATURES Fully height and angle adjustable; Fits to any common drum rim
RIMCLAMP, RIMCLAMP-2: Holds percussion accessories right where you need them; Great for percussion rigs, drum kit setups, and marching drums
RIMCLAMP-M: Works with all 3/8" or 5/8" mic clips (Mic clip not included)
INCLUDES **RIMCLAMP:** L-shaped rod
RIMCLAMP-M: Flexible Microphone Gooseneck

16 PROFESSIONAL MULTI-CLAMPS

MATERIALS Black powder coated die cast steel
TMPMC-G: Metal (Gooseneck)
TMPMC-R: Chrome plated steel (Z-shaped rod)
FEATURES 360-degree adjustable 3/8" rod eye bolt mount
TMPMC: Strong clamp secures to any drum set or percussion rim; Fine tune the placement of your percussion gear
TMPMC-G: Removable flexible microphone gooseneck; Strong clamp secures to any drum set or percussion rim; Get optimal placement of your microphone
TMPMC-R: Removable Z-shaped 3/8" rod to mount percussion instruments; Strong clamp secures to any drum set or percussion rim; Get optimal placement of your gear

BAGS



BAGS

MATERIAL Heavy-duty nylon
(unless noted otherwise)

1 CAJON GIG BAG

SIZE 20 1/2" W x 12" H x 12" D
FEATURE Carrying grip

2 PROFESSIONAL CAJON BAGS

SIZES **MCJB, MCJB-CG:**
20 1/2" W x 12" H x 12" D
MCJB-L: 23 1/2" W x 17" H x 15" D

MATERIAL **MCJB-CG:** Ripstop Fabric
FEATURES Padded shoulder strap; External pocket;
Carrying grip

MCJB-L: Fits bigger sized cajons
FINISH **MCJB-CG:** Carbon Grey

3 DELUXE CAJON BAG

SIZE 20 1/2" W x 12" H x 12" D
FEATURES Synthetic fur; Padded shoulder strap;
External pocket; Carrying grip

4 DELUXE BASS PEDAL CAJON BAG

SIZE 21 1/2" W x 17" H x 14 1/2" D
FEATURES Synthetic fur; Padded shoulder strap;
External pocket; Carrying grip

5 PROTECTION COVER FOR HEADLINER® CAJONS

FEATURE Fits all HCAJ1 models

6 CAJON BACKPACK

SIZE 13 1/2" W x 19 3/4" H x 14" D
FEATURES Backpack; Carrying grip

7 CAJON BACKPACK PRO

SIZE 12" W x 20 1/2" H x 12" D
MATERIAL Ripstop Fabric
FEATURES Padded backpack shoulder straps;
External pocket; Carrying grip
FINISH Carbon Grey

8 JAM CAJON GIG BAG

SIZE 12" W x 16" H x 12" D
FEATURES Fits all Jam Cajon models;
Strong carrying grip; Two-way zipper

9 PROFESSIONAL SLAPTOP CAJON BAG

SIZE 23" W x 15" H x 13" D
FEATURES Padded shoulder strap; External pocket;
Carrying grip

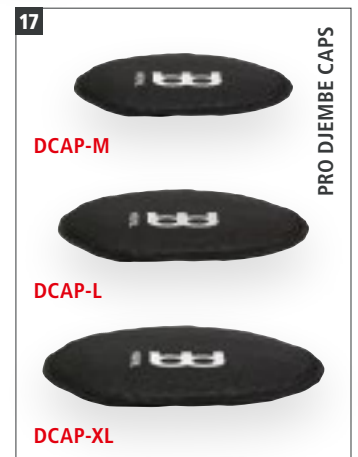

10 PROFESSIONAL HYBRID SLAPTOP CAJON BAG
 SIZE 17 1/2" W x 13" H x 8" D
 FEATURES Padded shoulder strap; Carrying grip

11 TRAVEL CAJON GIG BAG
 SIZE 12"
 FEATURES Double-slide zipper; Carrying grip

12 PROFESSIONAL CAJON PEDAL BAG
 SIZE 21" W x 12" H x 15" D
 FEATURES Padded shoulder strap; External pocket; Carrying grip; Padded dividers

13 DELUXE DJEMBE BAGS
 SIZES **M**: Medium (up to 12")
L: Large (up to 13 1/2")
 FEATURES Synthetic fur; External pocket; Padded backpack straps; Carrying grip

14 STANDARD DJEMBE BAGS
 SIZES **MSTDJB10**: Medium (10")
MSTDJB12: Large (12")
 FEATURES External pocket; Carrying grip

15 PROFESSIONAL DJEMBE BAGS
 SIZES **S**: Small (up to 10")
M: Medium (up to 12")
L: Large (up to 13 1/2")
 FEATURES External pocket; Carrying grip
MDJB-M, MDJB-L: Padded backpack straps

16 DJEMBE GIG BAG
 FEATURES Carrying grip; Shoulder strap; Outer pocket

17 PROFESSIONAL DJEMBE CAPS
 SIZES **M**: 10"; **L**: 12"; **XL**: 13"

18 CONGA GIG BAG
 FEATURES Carrying grip; Shoulder strap; Outer pocket

19 PROFESSIONAL CONGA BAGS
 SIZES **MCOB-11**: 11"
MCOB-1134: 11 3/4"
MCOB-1212: 12 1/2"
 FEATURES Additional upright zipper; External pocket; Padded backpack straps; Carrying grip

20 PROFESSIONAL PANDEIRO BAGS
 SIZES **MPAB-10**: 10"; **MPAB-12**: 12"
 FEATURES Double-slide zipper; Shoulder strap; External pocket
MPAB-12: Also fits for our 10" Tambourines

21 TAMBOURINE GIG BAG
 SIZE 10"
 FEATURES Sturdy zipper; Carrying grip

BAGS



BAGS

MATERIAL Heavy-duty nylon
(unless noted otherwise)

1 BONGO GIG BAG

SIZE Bongos up to 7 1/2" Macho & 8 1/2" Hembra
FEATURE Carrying grip

2 PROFESSIONAL BONGO BAG

FEATURES Additional room for accessories; Padded shoulder strap; Carrying grip; Padded separator

3 PROFESSIONAL TIMBALES BAG

SIZE 14" & 15"
FEATURES External pocket for stand and cowbell; Padded shoulder strap; Carrying grip; Padded separator

4 PROFESSIONAL SURDO BAGS

SIZES **MSUB-16:** 16" x 20"
MSUB-18: 18" x 22"
MSUB-20: 20" x 24"
MSUB-22: 22" x 24"

FEATURES Double-slide zipper; Padded backpack straps; Carrying grip; External pocket

5 PROFESSIONAL TIMBA BAGS

SIZES **MTIMB-1428:** 14" x 28"
MTIMB-1435: 14" x 35"

FEATURES Double-slide zipper; Padded backpack straps; Carrying grip; External pocket

6 PROFESSIONAL TANTAM BAG

SIZE 14" x 28"

FEATURES Double-slide zipper; Padded backpack straps; Carrying grip; External pocket

7 PROFESSIONAL REBOLO BAG

SIZE 12" x 18"

FEATURES Double-slide zipper; Padded shoulder strap; Carrying grip; External pocket

8 PROFESSIONAL REPINIQUE BAGS

SIZES **MREB-10:** 10" x 10"
MREB-12: 12" x 12"

FEATURES Double-slide zipper; Shoulder strap; Carrying grip; External pocket

9 PROFESSIONAL TAMBORIM BAG

SIZE 6"

FEATURES Double-slide zipper; Shoulder strap; External pocket



MQW-6 **MQW-7** **MQW-10**

PRO CUIXA BAGS



MCA-12 **MCA-12T** **MCA-14**

PRO CAIXA BAGS



MCHB

PRO CHIMES BAG



MFDB-14 **MFDB-16** **MFDB-18** **MFDB-20** **MFDB-22**

PRO FRAME DRUM BAGS



MFDB-12BE **MFDB-14BE** **MFDB-14IBO** **MFDB-18BO** **MFDB-22-D**

PRO DEEP SHELL FRAME DRUM BAGS



MFDB-7KA

PRO KANJIRA BAG

10 PROFESSIONAL CUIXA BAGS

- SIZES** **MQW-6:** 6"
MQW-7: 8"
MQW-10: 10"
- FEATURES** Padded shoulder strap; Carrying grip;
 External pocket

11 PROFESSIONAL CAIXA BAGS

- SIZES** **MCA-12:** 12" x 4 1/2"
MCA-12T: 12" x 6"
MCA-14: 14" x 4"
- FEATURES** Double-slide zipper; Shoulder strap;
 Extra pocket for spare heads;
 Carrying grip; External pocket

12 PROFESSIONAL CHIMES BAG

- FEATURES** Stores up to 2 chimes; Carrying grip;
 Inner hook and loop fastener straps;
 2 internal pockets

13 PROFESSIONAL FRAME DRUM BAGS

- SIZES** **MFDB-14:** 14", 2 1/2" deep
MFDB-16: 16", 2 1/2" deep
MFDB-18: 18", 2 1/2" deep
MFDB-20: 20", 2 1/2" deep
MFDB-22: 22", 2 1/2" deep
- FEATURES** Double-slide zipper; Shoulder strap;
 Carrying grip

14 PROFESSIONAL DEEP SHELL FRAME DRUM BAGS

- SIZES** **MFDB-12BE:** 12" x 4"
MFDB-14BE: 14" x 4"
MFDB-14IBO: 14" x 6"
MFDB-18BO: 18" x 4"
MFDB-22-D: 22" x 4"
- FEATURES** Double-slide zipper; Shoulder strap;
 Carrying grip

15 PROFESSIONAL KANJIRA BAG

- SIZE** 8 1/2" x 2 1/2"
- FEATURES** Double-slide zipper; Shoulder strap;
 External pocket

BAGS



BAGS

MATERIAL Heavy-duty nylon
(unless noted otherwise)

1 STANDARD DARBUKA BAG

SIZE Medium
FEATURES Carrying grip; Shoulder strap; Outer pocket

2 PROFESSIONAL DARBUKA BAG

FEATURES Double-slide zipper; Additional upright zipper; Padded shoulder strap; Carrying grip; External pocket

3 PROFESSIONAL IBO BAGS

SIZES **S:** Small (9 3/4" W x 13 1/3" H x 9 3/4" D)
M: Medium (11" W x 14 1/2" H x 11" D)
L: Large (11 3/4" W x 15" H x 11 3/4" D)
FEATURES Padded shoulder strap; Carrying grip; External pocket

4 STANDARD DOUMBЕК BAG

SIZE Medium
FEATURES Carrying grip; Shoulder strap; Outer pocket

5 PROFESSIONAL DOUMBЕК BAGS

SIZES **MDOB:** Medium
MDOB-L: Large
FEATURES Double-slide zipper; Additional upright zipper; Padded shoulder strap; Carrying grip; External pocket

6 STRAIGHT DIDGERIDOO BAG

SIZE 53"
FEATURES Padded shoulder strap; External pocket

7 PRO DIDGERIDOO BAG

SIZE 58"
FEATURES Padded shoulder strap; External pocket

8 PERCUSSION BACKPACK

MATERIAL Ripstop Fabric
FEATURES Travel backpack for small percussion instruments; Numerous pockets on the inside and outside; Padded backpack shoulder straps; Carrying grip
FINISH Carbon Grey

9 HAND PERCUSSION BAGS

SIZES **M:** Medium
L: Large
FEATURES Great for cowbells, blocks or small hand percussion; Drawstring top; Durable nylon prevents scuffs and scratches; No hassle storage or travel

10 CYMBAL GIG BAG

SIZE 22"
FEATURES Shoulder strap; Carrying grip

BAGS & DRUM RUGS



BAGS

DELUXE STICK BAG

DRUM RUGS

11 PROFESSIONAL CYMBAL BAG

SIZE 22"
FEATURES Padded dividers; Padded shoulder strap

12 PROFESSIONAL CYMBAL BACKPACK

SIZE 22"
FEATURES External hihat / splash compartment; Glow-in-the-dark MEINL logo; Two backpack straps on the backside

13 RIPSTOP CYMBAL BACKPACK

SIZE 22"
MATERIAL Ripstop Fabric
FEATURES Constructed of durable, lightweight ripstop material; 15" external hihat pocket; Accessories pocket on back side; Three thick cymbal dividers sewn into bag

14 COMPACT STICK BAG

FEATURE Carrying grip

15 PROFESSIONAL STICK BAGS

FEATURES External pockets; Shoulder straps; Extension straps
COLOURS **MSB-1:** Black
MSB-1-C1: Original Camouflage
MSB-2: The Horns

16 DELUXE STICK BAG

MATERIAL Padded synthetic leather
FEATURES External pockets; Shoulder straps; Elastic cord attachments

17 STICK SLING BAG

FEATURES Wider version of our Professional Stick Bag; Eleven internal pockets of varying size for any kind of stick, mallet, rod, brush or accessory; Oversized exterior pocket that can fit books, sheet music, practice pads or metronomes

18 DRUM RUGS

SIZES **MDRS:** 5.25 ft (160 cm) x 4.6 ft (140 cm)
MDRL: 6.5 ft (200 cm) x 6.5 ft (200 cm)

MATERIAL Woven fabric
FEATURES **MDRS**

Tightly woven fabric creates a strong rip with spurs and stands; Durable no-slip rubber bottom; Compact size for smaller drum or percussion setups; Ideal for smaller stage footprint

MDRL

Durable no-slip rubber bottom; Full-size for any drum or percussion setup; Ideal for drum risers

INCLUDES Travel bag
Strap

FINISHES **BK:** Black
OR: Oriental





Sometimes a Drum Circle is a big party, sometimes it's more like a ceremony, and other times it's orientated to a specific goal or message. The Drum Circle is a very adaptable technology to meet a broad spectrum of social purpose. For many people it is an initiation into a new level of self and group awareness. It definitely gets us moving!

No matter who we are, the call of the drum has the potential to elevate our human experience and people's lives become better because of that. Facilitating Rhythm Circles is an honor, a privilege, and also a responsibility. It is a fascinating and rewarding commitment.

Rhythm is a way of Life. [Bill Saragosa]

Djembes	02
Congas	04
Bass Drums	06
Stack Drum Sets	08
Timbas	08
Cajons	09
Hand Percussion	10
Bags	11

DJEMBES

1

BOOM SERIES

CUTTING SOUNDS WITH SHARP ATTACK



14" x 26 1/4"
VR-SDJ14-SH

12" x 23"
VR-SDJ12-SH

10" x 19 1/2"
VR-SDJ10-SH

9" x 16 1/2"
VR-SDJ9-SH

8" x 16 1/4"
VR-SDJ8-SH

2



THE POP OFF DJEMBE HEADS MAY BE ALSO PLAYED BY THEMSELVES AS A SMALL HAND DRUM

Set
VR-SDJSET-SH

SOFT SOUND SERIES

SOFTER SOUNDS WITH GREAT LOW END TONES



14" x 26 1/4"
VR-SDJ14-NH

12" x 23"
VR-SDJ12-NH

10" x 19 1/2"
VR-SDJ10-NH

9" x 16 1/2"
VR-SDJ9-NH

8" x 16 1/4"
VR-SDJ8-NH



STACKABLE FOR EASY STORAGE AND TRANSPORTATION

Set
VR-SDJSET-NH

1 COMMUNITY DJEMBES

- SIZES**
- VR-SDJ8
8" head diameter, 16 1/4" height
 - VR-SDJ9
9" head diameter, 16 1/2" height
 - VR-SDJ10
10" head diameter, 19 1/2" height
 - VR-SDJ12
12" head diameter, 23" height
 - VR-SDJ14
14" head diameter, 26 1/4" height

- MATERIALS**
- Synthetic shell
 - SH: Synthetic head
 - NH: Napa head

- FEATURES**
- Synthetic shell is perfect for outdoor playing
 - Non-slip rubber bottom
 - Great for any skill level or style
 - SH: Pre-tuned synthetic head for cutting sounds with sharp attack
 - NH: Pre-tuned Napa head creates softer, warmer sound

2 3-IN-1 DJEMBES

- SIZES**
- 8" head diameter, 16 1/4" height
 - 10" head diameter, 19 1/2" height
 - 12" head diameter, 23" height

- MATERIALS**
- Synthetic shell
 - SH: Synthetic head
 - NH: Napa head

- FEATURES**
- Synthetic shell is perfect for outdoor playing
 - Non-slip rubber bottom
 - Great for any skill level or style
 - Stackable for easy storage and transportation
 - SH: Pre-tuned synthetic head for cutting sounds with sharp attack
 - NH: Pre-tuned Napa head creates softer, warmer sound

3

BOOM SERIES
CUTTING SOUNDS WITH SHARP ATTACK

CAN BE TAKEN OFF THE DRUM INSTANTLY WITHOUT ANY TUNING



14" x 26 1/4" **VR-SDJPO14-SH** 12" x 23" **VR-SDJPO12-SH** 10" x 19 1/2" **VR-SDJPO10-SH** 9" x 16 1/2" **VR-SDJPO9-SH** 8" x 16 1/4" **VR-SDJPO8-SH**

SOFT SOUND SERIES
SOFTER SOUNDS WITH GREAT LOW END TONES



14" x 26 1/4" **VR-SDJPO14-NH** 12" x 23" **VR-SDJPO12-NH** 10" x 19 1/2" **VR-SDJPO10-NH** 9" x 16 1/2" **VR-SDJPO9-NH** 8" x 16 1/4" **VR-SDJPO8-NH**

4

14" **VR-POH14-SH**
12" **VR-POH12-SH**
10" **VR-POH10-SH**
9" **VR-POH9-SH**
8" **VR-POH8-SH**



14" **VR-POH14-NH**
12" **VR-POH12-NH**
10" **VR-POH10-NH**
9" **VR-POH9-NH**
8" **VR-POH8-NH**



MAY BE PLAYED BY THEMSELVES AS A SMALL HAND DRUM

DJEMBES

3 POP OFF DJEMBES
SIZES **VR-SDJPO8** 8" head diameter, 16 1/4" height
VR-SDJPO9 9" head diameter, 16 1/2" height
VR-SDJPO10 10" head diameter, 19 1/2" height
VR-SDJPO12 12" head diameter, 23" height
VR-SDJPO14 14" head diameter, 26 1/4" height
MATERIALS Synthetic shell
SH: Synthetic head
NH: Napa head

FEATURES Synthetic shell is perfect for outdoor playing
Non-slip rubber bottom
Great for any skill level or style
SH: Removable, pre-tuned synthetic head for cutting sounds with sharp attack
NH: Removable, pre-tuned Napa head creates softer, warmer sound

4 POP OFF HEADS
SIZES **VR-POH8:** 8" head diameter
VR-POH9: 9" head diameter
VR-POH10: 10" head diameter
VR-POH12: 12" head diameter
VR-POH14: 14" head diameter
MATERIALS **SH:** Synthetic head
NH: Napa head
FEATURES Available as Napa style (soft sound) or standard synthetic (sharp sounds)
Instantly take on or off your MEINL VivaRhythm® Pop Off Djembe
May be played by themselves as a small hand drum
Nylon-loop for easy removal
Pre-tuned

CONGAS

1

BOOM SERIES

CUTTING SOUNDS WITH SHARP ATTACK



STACKABLE FOR EASY STORAGE AND TRANSPORTATION



11 1/2" x 24 1/2"
VR-C115-SH

9 1/2" x 23"
VR-C95-SH

8" x 21"
VR-C8-SH

Set
VR-CSET-SH

SOFT SOUND SERIES

SOFTER SOUNDS WITH GREAT LOW END TONES



SETS INCLUDE THREE WOODEN BEATERS

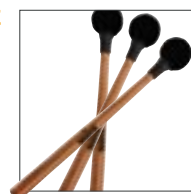

11 1/2" x 24 1/2"
VR-C115-NH

9 1/2" x 23"
VR-C95-NH

8" x 21"
VR-C8-NH

Set
VR-CSET-NH

1 COMMUNITY CONGAS

SIZES
VR-C8
 8" head diameter, 21" height
VR-C95
 9 1/2" head diameter, 23" height
VR-C115
 11 1/2" head diameter, 24 1/2" height
VR-CSET
 8" x 21"; 9 1/2" x 23"; 11 1/2" x 24 1/2"

MATERIALS
 Synthetic shell
SH: Synthetic head
NH: Napa head

FEATURES
 Synthetic shell is perfect for outdoor playing
 Non-slip rubber bottom
 Great for any skill level or style
 Stackable for easy storage and transportation
SH: Pre-tuned synthetic head for cutting sounds with sharp attack
NH: Pre-tuned Napa head creates softer, warmer sound

INCLUDES
VR-CSET: Three wooden beaters



2

CAN BE TAKEN OFF THE DRUM INSTANTLY WITHOUT ANY TUNING

BOOM SERIES
CUTTING SOUNDS WITH SHARP ATTACK

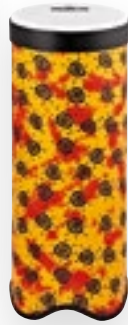

11 1/2" x 24 1/2"
VR-CP0115-SH

9 1/2" x 23"
VR-CP095-SH

8" x 21"
VR-CP08-SH

Set
VR-CPOSET-SH

3



11 1/2"
VR-POH115-SH



9 1/2"
VR-POH95-SH



8"
VR-POH8-SH

STACKABLE FOR EASY STORAGE AND TRANSPORTATION

SOFT SOUND SERIES
SOFTER SOUNDS WITH GREAT LOW END TONES

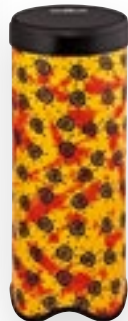

11 1/2" x 24 1/2"
VR-CP0115-NH

9 1/2" x 23"
VR-CP095-NH

8" x 21"
VR-CP08-NH

Set
VR-CPOSET-NH



11 1/2"
VR-POH115-NH



9 1/2"
VR-POH95-NH



8"
VR-POH8-NH

MAY BE PLAYED BY THEMSELVES AS A SMALL HAND DRUM

CONGAS

2 POP OFF CONGAS

SIZES

- VR-CP08**
8" head diameter, 21" height
- VR-CP095**
9 1/2" head diameter, 23" height
- VR-CP0115**
11 1/2" head diameter, 24 1/2" height
- VR-CPOSET**
8" x 21"; 9 1/2" x 23"; 11 1/2" x 24 1/2"

MATERIALS

- Synthetic shell
- SH:** Synthetic head
- NH:** Napa head

FEATURES

Synthetic shell is perfect for outdoor playing
Non-slip rubber bottom
Great for any skill level or style
Stackable for easy storage and transportation
SH: Removable, pre-tuned synthetic head for cutting sounds with sharp attack

NH: Removable, pre-tuned Napa head creates softer, warmer sound

INCLUDES

VR-CPOSET: Three wooden beaters

3 POP OFF HEADS

SIZES

- VR-POH8:** 8" head diameter
- VR-POH95:** 9 1/2" head diameter
- VR-POH115:** 11 1/2" head diameter

MATERIALS

- SH:** Synthetic head
- NH:** Napa head

FEATURES

Available as Napa style (soft sound) or standard synthetic (sharp sounds)
Instantly take on or off your MEINL VivaRhythm® Pop Off Conga
May be played by themselves as a small hand drum
Nylon-loop for easy removal
Pre-tuned

BASS DRUMS

1

BOOM SERIES

CUTTING SOUNDS WITH SHARP ATTACK



STACKABLE FOR EASY STORAGE AND TRANSPORTATION



14" x 23 1/2"
VR-BD14-SH

12" x 19 1/2"
VR-BD12-SH

10" x 18"
VR-BD10-SH

Set
VR-BDSET-SH

SOFT SOUND SERIES

SOFTER SOUNDS WITH GREAT LOW END TONES



SETS INCLUDE THREE WOODEN BEATERS



14" x 23 1/2"
VR-BD14-NH

12" x 19 1/2"
VR-BD12-NH

10" x 18"
VR-BD10-NH

Set
VR-BDSET-NH

1 COMMUNITY BASS DRUMS

SIZES
VR-BD10
 10" head diameter, 18" height
VR-BD12
 12" head diameter, 19 1/2" height
VR-BD14
 14" head diameter, 23 1/2" height
VR-BDSET
 10" x 18"; 12" x 19 1/2"; 14" x 23 1/2"

MATERIALS Synthetic shell
SH: Synthetic head
NH: Napa head

FEATURES Synthetic shell is perfect for outdoor playing
 Non-slip rubber bottom
 Great for any skill level or style
 Lower tones with great resonance
 Reverse Dot below the head for deeper sounds
 Stackable for easy storage and transportation
SH: Pre-tuned synthetic head for cutting sounds with sharp attack
NH: Pre-tuned Napa head creates softer, warmer sound

INCLUDES **VR-BDSET:** Three wooden beaters

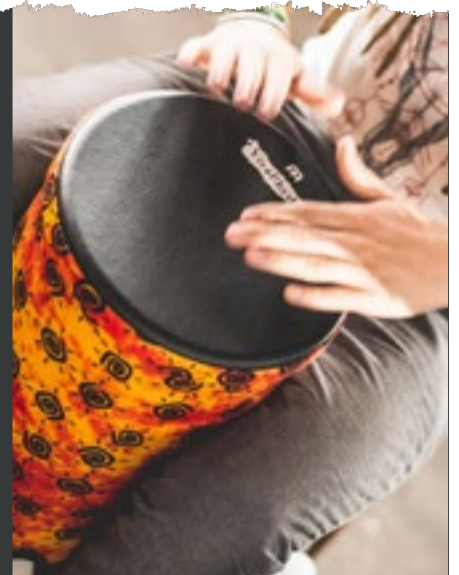

2

CAN BE TAKEN OFF THE DRUM INSTANTLY WITHOUT ANY TUNING

BOOM SERIES
CUTTING SOUNDS WITH SHARP ATTACK



14" x 23 1/2"
VR-BDPO14-SH

12" x 19 1/2"
VR-BDPO12-SH

10" x 18"
VR-BDPO10-SH

Set
VR-BDPOSET-SH

3



14"
VR-POHBD14-SH



12"
VR-POHBD12-SH



10"
VR-POHBD10-SH

REVERSE-DOT FOR DEEPER SOUNDS

STACKABLE FOR EASY STORAGE AND TRANSPORTATION

SOFT SOUND SERIES
SOFTER SOUNDS WITH GREAT LOW END TONES



14" x 23 1/2"
VR-BDPO14-NH

12" x 19 1/2"
VR-BDPO12-NH

10" x 18"
VR-BDPO10-NH

Set
VR-BDPOSET-NH



14"
VR-POHBD14-NH



12"
VR-POHBD12-NH



10"
VR-POHBD10-NH

BASS DRUMS

2 POP OFF BASS DRUMS

SIZES **VR-BDPO10**
10" head diameter, 18" height
VR-BDPO12
12" head diameter, 19 1/2" height
VR-BDPO14
14" head diameter, 23 1/2" height
VR-BDPOSET
10" x 18"; 12" x 19 1/2"; 14" x 23 1/2"

MATERIALS Synthetic shell
SH: Synthetic head
NH: Napa head

FEATURES Synthetic shell is perfect for outdoor playing
Non-slip rubber bottom
Great for any skill level or style
Lower tones with great resonance
Reverse Dot below the head for deeper sounds
Stackable for easy storage and transportation
SH: Removable, pre-tuned synthetic head for cutting sounds with sharp attack
NH: Removable, pre-tuned Napa head creates softer, warmer sound

INCLUDES **VR-BDPOSET:** Three wooden beaters

3 POP OFF BASS DRUM HEADS

SIZES **VR-POHBD10:** 10" head diameter
VR-POHBD12: 12" head diameter
VR-POHBD14: 14" head diameter

MATERIALS **SH:** Synthetic head
NH: Napa head

FEATURES Available as Napa style (soft sound) or standard synthetic (sharp sounds)
Instantly take on or off your MEINL VivaRhythm® Pop Off Bass Drum
Reverse Dot below the head for deeper sounds
May be played by themselves as a small hand drum
Nylon-loop for easy removal
Pre-tuned

STACK DRUM SETS & TIMBAS

1

STACKABLE FOR EASY STORAGE AND TRANSPORTATION



BOOM SERIES
CUTTING SOUNDS WITH SHARP ATTACK



Set
VR-SDSET-SH

2

BASED ON THE SOUNDS OF TRADITIONAL SAMBA MUSIC



12" x 28"
VR-T12-SH

CAN BE TAKEN OFF THE DRUM INSTANTLY WITHOUT ANY TUNING



SOFT SOUND SERIES
SOFTER SOUNDS WITH GREAT LOW END TONES



Set
VR-SDSET-NH



12" x 28"
VR-T12-NH

1 STACK DRUM SETS

SIZES 9 1/2" head diameter, 17 1/4" height
12" head diameter, 24" height

MATERIALS Synthetic shell
SH: Synthetic head
NH: Napa head

FEATURES Synthetic shell is perfect for outdoor playing
Stackable for easy storage and transportation
Non-slip rubber bottom
Great for any skill level or style
SH: Pre-tuned synthetic head for cutting sounds with sharp attack
NH: Pre-tuned Napa head creates softer, warmer sound

2 TIMBAS

SIZE 12" head diameter, 28" height

MATERIALS Fiberglass shell
SH: Synthetic head
NH: Napa head

FEATURES Fiberglass shell is perfect for outdoor playing
Based on the sounds of traditional Samba music
Non-slip rubber bottom
Great for any skill level or style
SH: Pre-tuned synthetic head for cutting sounds with sharp attack
NH: Pre-tuned Napa head creates softer, warmer sound



VR-CAJ-SO



VR-TRICAJ-SO



3 DIFFERENT SOUND OPTIONS

POPS UP FROM A FLAT PIECE INTO A FULL SIZE CAJON



VR-CAJ2GO



DEEP BASS TONES

caiXoN
VR-CAIX

FORWARD FACING SOUND PORT



HIGHER TONES

caiXoNet
VR-CAIXN



Set
VR-CAIX/CAIXN



STACKABLE FOR EASY STORAGE AND TRANSPORTATION

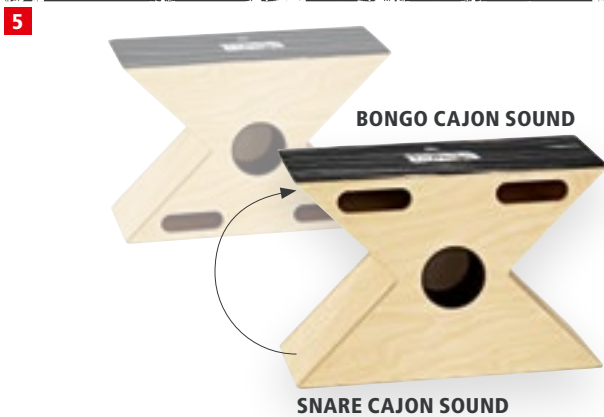

BONGO CAJON SOUND

SNARE CAJON SOUND



CONTRASTING PLAYING SURFACES ON OPPOSITE SIDES

VR-XCAJ-SO

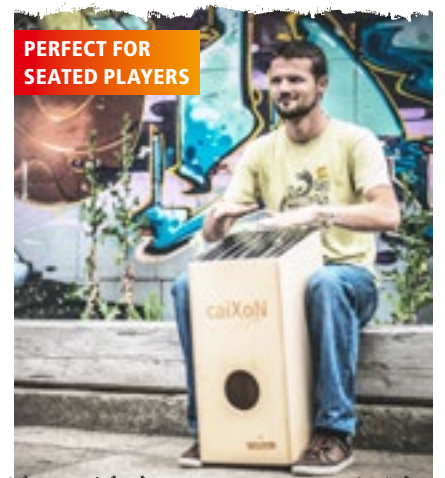

PERFECT FOR SEATED PLAYERS

1 SNARE CAJON
SIZE 11 3/4" W x 17 3/4" H x 12" D
MATERIALS Resonating body: Baltic Birch (*Betula pendula*)
 Frontplate: Striped Onyx
FEATURES Two internal snare wires
 Birch construction
 Four rubber feet
 Wide sound options

3 CAJON2GO
SIZE 13 1/2" W x 18" H x 12 1/2" D
MATERIAL Cardboard
FEATURES Folds from a single flat piece into a full size cajon
 Internal fixed set of snare wires
 Comfortably holds up to 150 kg / 330 lbs
 Naturally deep bass and crisp snare sounds

Perfect for seated players
 Forward facing sound port
VR-CAIX: Deep bass tones
VR-CAIXN: Higher tones
VR-CAIX/CAIXN: Includes large caiXoN and smaller caiXoNet
 Stackable for easy storage and transportation

2 TRI TONE CAJON
SIZE 11 3/4" W x 19 1/2" H x 13" D
MATERIALS Resonating body: Baltic Birch (*Betula pendula*)
 Playing surfaces: Striped Onyx
FEATURES 3 different cajon sound options all in one unit: Bongo cajon (1); Snare cajon (2); Peruvian style cajon (3)
 Two internal snare wires for the snare section

4 CAIXON & CAIXONET
SIZES **VR-CAIX** (caiXoN) 11 1/2" W x 26 1/4" H x 12" D
VR-CAIXN (caiXoNet) 10 1/2" W x 26 1/4" H x 9 1/2" D
MATERIALS Resonating body: Baltic Birch (*Betula pendula*)
 Playing surface: Striped Onyx
FEATURES Internal snare wires for cutting snare slaps

5 X-CAJON
SIZE 14 1/2" W x 10" H x 5 3/4" D
MATERIALS Resonating body: Baltic Birch (*Betula pendula*)
 Playing surfaces: Striped Onyx
FEATURES Comfortable and unique X-design
 Forward sound projection
 Internal snare wires for a snare cajon sound on one side
 Bongo cajon sound on the opposite side

STACKS, TIMBAS & CAJONS

HAND PERCUSSION

1



VR-TA2-ROM

2



VR-ABS1



3



RICH TONES

VR-HCB-R

4



Set
VR-ES2

5



VR-CSH

1 WOOD TAMBOURINE

SIZE 10" diameter
MATERIALS Black plated steel jingles
 Siam Oak (*Hevea brasiliensis* Muell.-Arg.)
FEATURES Steel jingles create bright, high pitched sounds
 Double row
 Sturdy wooden frame in colourful finish
 Ergonomic grip
FINISH Red/orange marble

2 ABS PLASTIC TAMBOURINE

SIZE 8" diameter
MATERIALS Black plated steel jingles
 ABS plastic

FEATURES Steel jingles create bright, high pitched sounds
 Single row
 Sturdy ABS plastic frame in a colourful finish
 Extra wide grip
FINISH Red/orange

3 HAND COWBELL

SIZE 8" long
MATERIALS Powder coated steel
 ABS Plastic
FEATURES Muffled, firm sound
 Handheld
 Rich tones
INCLUDES Cowbell beater with ribbed grip
COLOUR Red

4 EGG SHAKER PAIR

MATERIAL Plastic
FEATURES Precise, cutting sound
 Comes in a set of two
COLOUR Red/orange

5 CRYSTAL SHAKER

SIZE 8 1/4" long
MATERIALS Plastic
 Acrylic glass
FEATURES Shapes any groove with clarity and feel
 Transparent body allows to follow the movement of the filling as an learning effect
 Perfect for live playing
COLOUR Red/orange

1 **ADJUSTABLE BACKPACK STRAPS**



VR-DJB-14 VR-DJB-12 VR-DJB-10 VR-DJB-9

2 **CARRY ALL THREE SIZES OF MEINL VIVARHYTHM® CONGAS**



VR-CSETB

3 **CARRY ALL THREE SIZES OF MEINL VIVARHYTHM® BASS DRUMS**



VR-BDSETB

4 **CARRY BOTH SIZES OF MEINL VIVARHYTHM® STACK DRUM SET**



VR-SDSETB

5 **ADJUSTABLE BACKPACK STRAPS**



VR-TB

6 **ADJUSTABLE SHOULDER STRAP**



VR-XCAJB

7 **FITS MOST COMMON CAJON SIZES**



VR-CAJB

8 **ADJUSTABLE SHOULDER STRAP**



VR-TRICAJB

9 **FITS CAIXON AND CAIXONET STACKED OR INDIVIDUAL**



VR-CAIXB

HAND PERCUSSION & BAGS

BAGS

MATERIAL Heavy-duty padded nylon
FEATURES Carrying handle with reinforced nylon stitching; Durable zipper
COLOUR Black

1 DJEMBE BAGS

SIZES **VR-DJB-9:** 11 1/2" x 17 1/4"
VR-DJB-10: 11 3/4" x 19 3/4"
VR-DJB-12: 13 3/4" x 24 1/2"
VR-DJB-14: 15 3/4" x 27 1/2"

FEATURES Adjustable backpack straps
VR-DJB-9 Holds 8" & 9" diameter djembes
VR-DJB-10 Holds 10" diameter djembes
VR-DJB-12 Holds 12" diameter djembes
VR-DJB-14 Holds 14" diameter djembes

2 CONGA SET BAG

SIZE 13" x 26"
FEATURES Adjustable backpack straps
 Carry all three sizes of MEINL VivaRhythm® Congas

3 BASS DRUM SET BAG

SIZE 16 1/4" x 25 1/4"
FEATURES Adjustable backpack straps
 Carry all three sizes of MEINL VivaRhythm® Bass Drums

4 STACK DRUM SET BAG

SIZE 13 1/2" x 24 1/2"
FEATURES Adjustable backpack straps
 Carry both sizes of MEINL VivaRhythm® Stack Drum Set

5 TIMBA BAG

SIZE 13 1/2" x 29"

FEATURE Adjustable backpack straps

6 X-CAJON BAG

SIZE 18 1/4" W x 13 1/2" H x 8" D
FEATURE Adjustable shoulder strap

7 CAJON BAG

SIZE 20 1/2" W x 13 1/2" H x 12" D
FEATURE Fits most common cajon sizes

8 TRI TONE CAJON BAG

SIZE 21" W x 13" H x 13 1/2" D
FEATURE Adjustable shoulder strap

9 CAIXON & CAIXONET BAG

SIZE 31" W x 12 1/2" H x 13 1/2" D
FEATURES Adjustable shoulder strap
 Fits caiXoN and caiXoNet stacked or individual



Learning to play an instrument and making music are life-changing things to do, especially for children.

Starting this in early childhood nurtures many things including perception, motor skills and the ability to learn and retain information. Making music also promotes personal confidence and social skills. These are all beneficial well beyond one's childhood years.

NINO® Percussion offers an outstanding collection of musical instruments designed specifically for children. These more than meet the requirements of early childhood music education and are ideal for kindergarten and school programs, or for music therapy and other music-making activities.

It is important to know that NINO® Percussion instruments are not toys. These are the real thing, designed for safety, durability, attractiveness and playability. Most importantly, they are in tune and musical. In fact, the only difference between NINO® Percussion instruments and those created for adults is their size and colour.

These appealing and pleasing designs are of a very high quality and include a wide variety of sound choices, making them popular with young players, as well as teachers and parents. Whether played alone or with a group, the performance and sound quality of NINO® Percussion instruments make them the ideal choice for young musicians and those who teach them.



Classroom Percussion	02-03	Tambourines	12
Cajons	04-05	Rhythm Sets	13
Djembes	06-07	Shakers	14-16
Synthetic & ABS Djembes	06	Egg Shakers	14
Wood Djembes	07	"Fruit & Vegetable" Shakers	15
Bongos	08	Maracas	17
Congas	09	Hand Percussion	18-21
Frame Drums	10-11	Steel Tongue Drums	22
ABS Frame Drums	10	Cymbals	22
Wood Frame Drums	11		

CLASSROOM PERCUSSION

1

3+



NINO954

2

3+



NINO954-2

3

3+



NINO957

4

3+

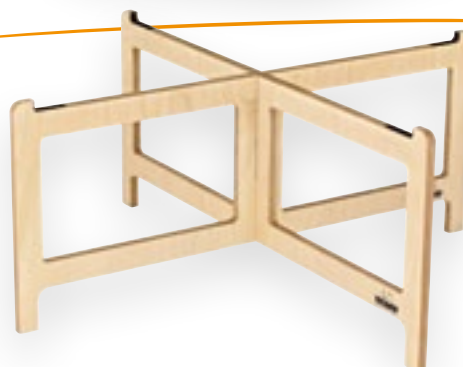

NINO958

5

3+



Set, 8 pcs.
NINO959

1 CLASSROOM CAJON

SIZE 34" diameter
MATERIAL Baltic Birch (*Betula*)
FEATURES Eight individual cajons connected in one unit
 Multi-coloured playing surfaces
 Ultimate drum circle experience
 Internal snare wires
COLOUR Multi-colour

2 DELUXE CLASSROOM CAJON

SIZE 36" diameter
MATERIAL Baltic Birch (*Betula*)
FEATURES Eight separate cajons
 Birch wood baseplate to hold the cajons together
 Great for easy storage
 Ultimate drum circle experience
 Internal snare wires
COLOUR Multi-colour

3 WOODEN CLASSROOM CAJON STAND

SIZE 34.5" diameter
MATERIAL Baltic Birch (*Betula*)
FEATURES Two piece assembly
 Designed for the NINO® Classroom cajon (NINO954)
 Protective corners to keep from scratching
COLOUR Natural

4 WOODEN DELUXE CLASSROOM CAJON STAND

SIZE 36.5" diameter
MATERIAL Baltic Birch (*Betula*)
FEATURES Two piece assembly
 Designed for the NINO® Deluxe Classroom cajon (NINO954-2)
 Protective corners to keep from scratching
COLOUR Natural

6 3+



NINO965

7 3+



NINO966



5 CLASSROOM CAJON STOOLS

SIZE 12.5" height
MATERIAL Baltic Birch (*Betula*)
FEATURES Eight stools for the NINO® Classroom Cajons and NINO® Classroom Hand Drum Set with Stand
 Perfect height to play the NINO® Classroom cajon when it's placed on a stand
COLOUR Multi-colour

6 HAND DRUM PAIR WITH STAND

SIZE 23 1/4" W x 12" H x 14" D
MATERIALS Hand drums: ABS plastic
 Stand: Baltic Birch (*Betula*)
FEATURES Hand drum pair with wooden stand
 Durable synthetic drums produce high and low notes
 Perfect for encouraging growth in music
 Easy to assemble and tear down for storage
INCLUDES One pair of wooden beaters

7 CLASSROOM HAND DRUM SET WITH STAND

SIZE 36" diameter
MATERIALS Hand drums: ABS plastic
 Stand: Baltic Birch (*Betula*)
FEATURES Four durable synthetic hand drum pairs that produce high and low notes
 One large central drum for everyone to play at once
 The ultimate drum circle experience for young musicians
 Encourages group participation in classrooms
 Easy to assemble and tear down for storage
INCLUDES Wooden stand
 Four pairs of wooden beaters

CAJONS

1

4+



Blue
NINO950B



Green
NINO950GR



Yellow
NINO950Y



Orange
NINO950OR



Red
NINO950R

10+

2

10+



Natural
NINO950

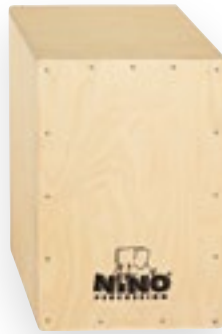

Natural
NINO952

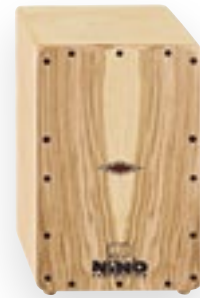

White Oak
AE-NINO951

3

10+

4

3+



Grey
NINO952GY



Salmon
NINO952SA



Turquoise
NINO952TU



Dark Green
NINO951DG

1 CAJONS

SIZE NINO950
9 3/4" W x 13" H x 9 1/2" D
NINO952
12" W x 17 3/4" H x 11 3/4" D

MATERIALS Frontplate: Baltic Birch (*Betula*)
Resonating Body: Baltic Birch (*Betula*)

FEATURES Internal snare wires
Adjustable top corners

COLOURS B: Blue
GR: Green
OR: Orange
R: Red
Y: Yellow

2 ARTISAN EDITION CAJON, NINO LINE

SIZE 9" W x 14 3/4" H x 9 1/2" D

MATERIALS Frontplate: White Oak
Resonating Body: Baltic Birch (*Betula*)

FEATURES 8 pre-tuned internal metal strings for a sensitive snare effect
Baltic Birch resonating body with rear port
Made in Spain

3 BETTER LIFE SERIES CAJONS

SIZE 12" W x 17 3/4" H x 11 3/4" D

MATERIALS Frontplate: Baltic Birch (*Betula*)
Resonating Body: Baltic Birch (*Betula*)

FEATURES Internal snare wires
Adjustable top corners

COLOURS GY: Grey
SA: Salmon
TU: Turquoise

4 CHALKBOARD CAJON

SIZE 10 1/4" W x 15" H x 10 1/4" D

MATERIAL Baltic Birch (*Betula*)

FEATURES Internal snare wires
Adjustable top corners
Great to learn fundamentals of rhythm
Customizable frontplate

INCLUDES Chalk pack, 7 different colours

COLOUR DG: Dark Green

5 BONGO CAJONS

SIZE 12" W x 5 1/2" H x 5" D

MATERIAL Baltic Birch (*Betula*)

FEATURE High and low pitch playing surface

COLOURS GR: Green
R: Red

5

3+



Natural
NINO931



Green
NINO931GR



Red
NINO931R

6

4+



Natural
NINO953

7

5+



Natural
NINO951-MYO

8

5+



Dark Green
NINO951DG-MYO



MAKE YOUR OWN CAJON

6 SLAPTOP CAJON

SIZE 15" W x 8" H x 7.5" D
MATERIAL Baltic Birch (*Betula*)
FEATURES Low and high notes for various beat combinations
 Internal snare wires
 Forward facing sound ports
 Sits comfortably in the lap
COLOUR Natural

1 x rear panel
 1 x playing surface (with NINO® logo)
 2 x side battens
 1 x base & 1 x top batten
 1 x securing batten for the snare
 1 x snare
 4 x rubber feet
 15 x screws, 3 x 20 mm (for playing surface)
 4 x screws, 4 x 15 mm (for rubber feet)
 2 x screws, 3 x 12 mm (for snare)

CONTAINS 1 x assembly instructions in nine languages
 2 x side panels
 1 x base panel
 1 x top panel
 1 x rear panel
 1 x snare
 2 x side battens
 1 x base & 1 x top batten
 1 x securing batten for the snare
 1 x snare
 4 x rubber feet
 15 x screws, 3 x 20 mm (for playing surface)
 4 x screws, 4 x 15 mm (for rubber feet)
 2 x screws, 3 x 12 mm (for snare)

7 MAKE YOUR OWN CAJON

SIZE 10.25" W x 15" H x 10.25" D
MATERIALS Resonating Body: Baltic Birch (*Betula*)
 Frontplate: Baltic Birch (*Betula*)
FEATURES Internal snare wires
 Includes stencil designs
CONTAINS 1 x assembly instructions in nine languages
 2 x side panels
 1 x base panel
 1 x top panel

COLOUR Natural

8 MAKE YOUR OWN CHALKBOARD CAJON

SIZE 10.25" W x 15" H x 10.25" D
MATERIALS Resonating Body: Baltic Birch (*Betula*)
 Frontplate: Baltic Birch (*Betula*)
FEATURES Internal snare wires
 Includes stencil designs

COLOUR **DG:** Dark Green

SYNTHETIC & ABS DJEMBES

1



3+



2

5+

3

5+

4+



Red/Black
NINO18R/BK

Green/Yellow
NINO18G/Y

Sunshine, 10"
NINO-PDJ1-M-F

Sunshine, 10"
NINO-PDJ1-M-G

Sunshine, 8"
NINO-PDJ1-S-F

Sunshine, 8"
NINO-PDJ1-S-G

1 ELEMENTS MINI DJEMBES

SIZE 6" diameter, 10 1/2" tall
MATERIALS Synthetic shell
 Plastic head
FEATURES 100% plastic head and shell is perfect for outdoor playing
 Ultra light weight makes them easy to carry
 Compact size
COLOURS **BB:** Blueberry
BG: Bubble Gum
CM: Copper Metallic
FB: Flat Black
FE: Fire Engine
GA: Green Apple
GM: Gold Metallic
GP: Grape
KQ: Kenyan Quilt
LE: Lemon
PS: Pharaoh's Script
SF: Sea Foam

SM: Silver Metallic
SN: Snow
SU: Sunshine
T: Tangerine
TA: Twisted Amber

2 ABS DJEMBES

SIZE 8" diameter, 13 3/4" tall
MATERIALS ABS plastic
 Synthetic heads
INCLUDES Nylon strap
COLOURS **G/Y:** Green/Yellow
R/BK: Red/Black

3 ROPE TUNED SYNTHETIC DJEMBES

SIZES **S:** 8" diameter, 16" tall
M: 10" diameter, 21" tall
MATERIALS Synthetic shell
F: Synthetic head
G: Hand selected goatskin head
PP ROPE 4 mm thickness, 30 runners
FEATURES 100% synthetic shell are perfect for outdoor playing
 Ultra light weight makes them easy to carry
 High quality PP nylon ropes
 Produces sharp slaps and deep bass tones
 Non-slip rubber bottom
FINISH Sunshine

WOOD DJEMBES



1 **4+** **3+** **4+** **3+**

EARTH RHYTHM SERIES



8"
NINO-ADJ3-S

7"
NINO-ADJ3-XS

4 1/2"
NINO-ADJ3-XXS

WATER RHYTHM SERIES



8"
NINO-ADJ2-S

7"
NINO-ADJ2-XS

4 1/2"
NINO-ADJ2-XXS

4+ **3+**

MOON RHYTHM SERIES



8"
NINO-ADJ4-S

7"
NINO-ADJ4-XS

4 1/2"
NINO-ADJ4-XXS

2



5+

10"
NINO48NT

DJEMBES

1 ORIGINAL AFRICAN STYLE ROPE TUNED WOOD DJEMBES

- SIZES** **XXS:** 4 1/2" diameter, 8" tall
XS: 7" diameter, 11 3/4" tall
S: 8" diameter, 15 3/4" tall
- MATERIALS** Mahogany Wood
 Hand selected goatskin heads
- PP ROPES** **XXS:** 3 mm thickness, 10 runners
XS: 3 mm thickness, 20 runners
S: 4 mm thickness, 20 runners
- FEATURES** Carved from one solid piece of plantation grown Mahogany Wood
 High quality PP nylon ropes
 Hand carved shells
- COLOURS** **ADJ2:** Brown (Water Rhythm Series)
ADJ3: Brown/Black (Earth Rhythm Series)
ADJ4: Black (Moon Rhythm Series)

2 WOOD DJEMBE

- SIZE** 10" diameter, 21" tall
- MATERIALS** Siam Oak (*Hevea brasiliensis* Muell.-Arg.)
 Hand selected goatskin head
- FEATURES** Rounded rim for playing comfort
 Black powder coated hardware
- INCLUDES** Tuning key
- COLOUR** **N:** Natural



BONGOS

1 4+



Green/Yellow
NINO19G/Y

2 5+



Blue
NINO17B-BK



Yellow
NINO17Y-BK



Red
NINO19R



Red
NINO17R-BK

3 5+



Natural/Black
NINO3NT-BK



4 5+



Natural/Harlekin
NINO3NT-HK



NINO20

1 ABS BONGOS

SIZES 6 1/2" Macho & 7 1/2" Hembra
MATERIALS ABS plastic
Synthetic heads
COLOURS **G/Y:** Green/Yellow
R: Red

2 ABS BONGOS PLUS

SIZES 6 1/2" Macho & 7 1/2" Hembra
MATERIALS ABS plastic
Hand selected buffalo heads
FEATURES Rounded rims for playing comfort
Black powder coated hardware
INCLUDES Tuning key
COLOURS **B-BK:** Blue Shell / Black Hardware
R-BK: Red Shell / Black Hardware
Y-BK: Yellow Shell / Black Hardware

3 WOOD BONGOS

SIZES 6 1/2" Macho & 7 1/2" Hembra
MATERIALS Siam Oak (*Hevea brasiliensis* Muell.-Arg.)
Hand selected buffalo heads
FEATURES Fully rounded rims for playing comfort
INCLUDES Tuning key
COLOURS **NT-BK:** Natural Shell / Black Hardware
NT-HK: Natural Shell / Harlekin Hardware

4 BONGO STAND

MATERIAL Chrome plated steel
FEATURES Fully height adjustable from 31" to 45"
90° angle adjustable
Tripod stand with rubber feet
Suitable for other common bongo models



CONGAS



1 5+



8" & 9"
NINO89NT

2 8+



9" & 10"
NINO910NT

3 5+

NEW



For 8" congas
NISTAND-08

For 9" congas
NISTAND-09

8+



For 9" congas
NISTAND9

For 10" congas
NISTAND10

1 NINO89 WOOD CONGA SET

- SIZES** 8" & 9" head diameter, 22" tall
- MATERIALS** Siam Oak (*Hevea brasiliensis* Muell.-Arg.)
Hand selected buffalo heads
- FEATURES** Rounded rims for playing comfort
Black powder coated hardware
- INCLUDES** Basket stands
Tuning key
- COLOUR** NT: Natural

2 NINO910 WOOD CONGA SET

- SIZES** 9" & 10" head diameter, 28" tall
- MATERIALS** Siam Oak (*Hevea brasiliensis* Muell.-Arg.)
Hand selected buffalo heads
- FEATURES** Rounded rims for playing comfort
Black powder coated hardware
- INCLUDES** Height adjustable basket stands with
quick set up system
Tuning key
- COLOUR** NT: Natural

3 CONGA BASKET STANDS

- SIZES** NISTAND-08: For 8" congas
NISTAND-09: For 9" congas
NISTAND9: For 9" congas
NISTAND10: For 10" congas
- MATERIAL** Black powder coated steel
- FEATURES** Holds your conga in place
Heavy construction
Leaves sound unaffected
NISTAND9, NISTAND10:
Height adjustable



BONGOS & CONGAS

ABS FRAME DRUMS

1



Sky Blue **NINO4SB** Grass Green **NINO4GG** Yellow **NINO4Y** Red **NINO4R** Strawberry Pink **NINO4SP**

3+



Sky Blue **NINO45SB** Grass Green **NINO45GG** Yellow **NINO45Y** Red **NINO45R** Strawberry Pink **NINO45SP**



Sky Blue **NINO5SB** Grass Green **NINO5GG** Yellow **NINO5Y** Red **NINO5R**

5+



Sky Blue **NINO6SB** Grass Green **NINO6GG** Yellow **NINO6Y** Red **NINO6R**

2



Set, 5 pcs.
NINOSET6

3+

3



Yellow **NINO5OW** Red **NINO5FT**

5+

1 ABS HAND DRUMS

SIZES **NINO4**: 6" diameter
NINO45: 8" diameter
NINO5: 10" diameter
NINO6: 12" diameter

MATERIALS ABS plastic frame
Synthetic head

INCLUDES Wooden beater

COLOURS **GG**: Grass Green
R: Red
SB: Sky Blue
SP: Strawberry Pink
Y: Yellow

2 ABS HAND DRUM SET

CONTAINS 1 x ABS Hand Drum 6" (NINO4Y)
1 x ABS Hand Drum 8" (NINO45SB)
1 x ABS Hand Drum 10" (NINO5GG)
1 x ABS Hand Drum 12" (NINO6R)

INCLUDES 4 x Wooden beater
1 x Red nylon bag

3 CUSTOMIZABLE ABS HAND DRUMS

SIZE 10" diameter

MATERIALS ABS plastic frame
Synthetic head

INCLUDES Wooden beater
Pack of safe to use coloured markers

COLOURS **FT**: Red (Fire Truck Graphic)
OW: Yellow (Owl Graphic)



WOOD FRAME DRUMS



14" NINO30 12" NINO35 10" NINO34 8" NINO44



12" NINO28 10" NINO27 8" NINO43 10" NINO32 8" NINO42



12" NINO39 10" NINO38



12" NINO37 10" NINO36

FRAME DRUMS

1 SEA DRUMS

SIZES NINO44: 8" diameter
NINO34: 10" diameter
NINO35: 12" diameter
NINO30: 14" diameter

MATERIALS Siam Oak frame
(*Hevea brasiliensis* Muell.-Arg.)
Two clear synthetic heads

FEATURE Soothing sounds

2 WOOD HAND DRUMS

SIZES NINO43: 8" diameter
NINO27: 10" diameter
NINO28: 12" diameter

MATERIALS Wooden frame
Synthetic head

3 HAND DRUMS WITH HANDLE

SIZES NINO42: 8" diameter
NINO32: 10" diameter

MATERIALS Wooden frame and handle
Synthetic head

FEATURE Ergonomically shaped wooden handle

4 TUNABLE HAND DRUMS WITH TRUE FEEL SYNTHETIC HEAD

SIZES NINO38: 10" diameter
NINO39: 12" diameter

MATERIALS Wooden frame
True Feel synthetic head

FEATURES Countersunk bolt lugs
Chrome plated hardware
Replaceable True Feel synthetic head

INCLUDES Tuning key

5 TUNABLE HAND DRUMS WITH GOATSKIN HEAD

SIZES NINO36: 10" diameter
NINO37: 12" diameter

MATERIALS Wooden frame
Hand selected goatskin head

FEATURES Countersunk bolt lugs
Chrome plated hardware
Replaceable hand selected goatskin head

INCLUDES Tuning key

TAMBOURINES



Sky Blue **NINO51SB** Grass Green **NINO51GG** Yellow **NINO51Y** Red **NINO51R** Strawberry Pink **NINO51SP**



Sky Blue **NINO24SB** Grass Green **NINO24GG** Yellow **NINO24Y** Red **NINO24R**

5+



Sky Blue **NINO49SB** Grass Green **NINO49GG** Yellow **NINO49Y** Red **NINO49R** Strawberry Pink **NINO49SP**

3+



1 row, 10" **NINO25** 2 rows, 10" **NINO26** 1 row, 8" **NINO47**

5+

3+



1 row, 10" **NINO14** 2 rows, 10" **NINO15** 1 row, 8" **NINO46** 2 rows, 8" **NINO50**

5+

3+

1 ABS TAMBOURINES

SIZES **NINO51**: 8" diameter
NINO24: 10" diameter
MATERIALS ABS plastic frame
Synthetic head
Nickel Silver plated steel jingles
INCLUDES Wooden beater
COLOURS **GG**: Grass Green
R: Red
SB: Sky Blue
SP: Strawberry Pink
Y: Yellow

2 COMPACT ABS TAMBOURINES

SIZE 8" diameter
MATERIALS ABS plastic frame
Stainless steel jingles
FEATURES Extra wide grip
Bright, cutting sound
Durable frame
1 row version
Compact size
COLOURS **GG**: Grass Green
R: Red
SB: Sky Blue
SP: Strawberry Pink
Y: Yellow

3 HEADED WOOD TAMBOURINES

SIZES **NINO47**: 8" diameter
NINO25, **NINO26**: 10" diameter
MATERIALS Wooden frame
Synthetic head
Nickel Silver plated steel jingles
FEATURES **NINO25**, **NINO47**: 1 row version
NINO26: 2 row version
INCLUDES Wooden beater

4 WOOD TAMBOURINES

SIZES **NINO46**, **NINO50**: 8" diameter
NINO14, **NINO15**: 10" diameter
MATERIALS Wooden frame
Nickel Silver plated steel jingles
FEATURES **NINO14**, **NINO46**: 1 row version
NINO15, **NINO50**: 2 row version

RHYTHM SETS



1



Set, 4 pcs.
NINOSET2



Set, 5 pcs.
NINOSET3



Set, 5 pcs.
NINOSET1



Set, 8 pcs.
NINOSET4

2



Set, 12 pcs.
NINOSET012

3+



Set, 15 pcs.
NINOSET515

3

3+

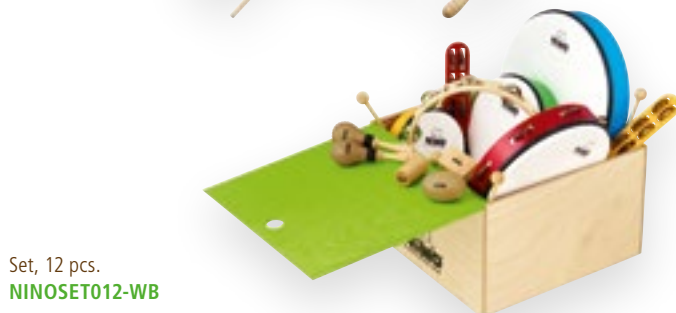

Set, 12 pcs.
NINOSET012-WB

Set, 15 pcs.
NINOSET515-WB



1 RHYTHM SETS

CONTAINS **NINOSET1**

- 1 x ABS Hand Drum, 6" (NINO4R)
- 1 x Wood Shaker, large (NINO2)
- 2 x Skin Maraca, small (pair) (NINO10)
- 1 x Jingle Stick (NINO13R)

NINOSET2

- 1 x Jingle Stick (NINO13R)
- 1 x Wood Claves pair, small (NINO502)
- 1 x Egg Shaker (NINO540LB)
- 1 x Egg Shaker (NINO540LY)

NINOSET3

- 1 x ABS Hand Drum, 6" (NINO4B)
- 1 x Jingle Stick (NINO13R)
- 1 x Wood Claves pair, small (NINO502)
- 1 x Egg Shaker (NINO540LGR)
- 1 x Egg Shaker (NINO540LY)

NINOSET4

- 1 x Wood Güiro (NINO555)
- 1 x Caxixi (NINO501)

- 1 x Wood Claves pair, small (NINO502)
- 1 x Triangle, 4" (NINO550)
- 1 x Egg Shaker (NINO540LB)
- 1 x Egg Shaker (NINO540LBK)
- 1 x "Banana" Shaker (NINO597)
- 1 x "Apple" Shaker (NINO596)

INCLUDES **NINOSET1, NINOSET4:** Harlekin bag

2 RHYTHM ASSORTMENT, 12 PCS.

CONTAINS **NINOSET012, NINOSET012-WB**

- 1 x ABS Hand Drum, 12" (NINO65B)
- 1 x ABS Tambourine, 10" (NINO24R)
- 1 x ABS Hand Drum, 8" (NINO45GG)
- 1 x ABS Hand Drum, 6" (NINO4Y)
- 2 x Skin Maraca, small (pair) (NINO10)
- 1 x Wood Block, large (NINO22)
- 1 x Skin Egg Shaker (NINO11)
- 1 x Jingle Stick, yellow (NINO13Y)
- 1 x Jingle Stick, red (NINO13R)
- 1 x Wood Tambourine, 10" (NINO14)

INCLUDES **NINOSET012-WB:** Wooden Box, big

3 RHYTHM ASSORTMENT, 15 PCS.

CONTAINS **NINOSET515, NINOSET515-WB**

- 1 x Wood Güiro (NINO555)
- 1 x Triangle, 6" (NINO551)
- 2 x Plastic Egg Maraca, red (NINO569R)
- 1 x Mini Güiro (NINO581R)
- 1 x Egg Shaker (NINO540LY)
- 1 x Racket Tambourine (NINO518)
- 1 x Wood Claves pair, small (NINO502)
- 1 x Energy Chimes, medium (NINO579M)
- 1 x Wood A-Go-Go, 2 rows (NINO560)
- 1 x Double Shaker (NINO503)
- 1 x Wood Shaker Assortment 3 pcs., triangular (NINO508)
- 1 x "Banana" Shaker (NINO597)

INCLUDES **NINOSET515:** Basket **NINOSET515-WB:** Wooden Box, small

EGG SHAKERS



NINO11

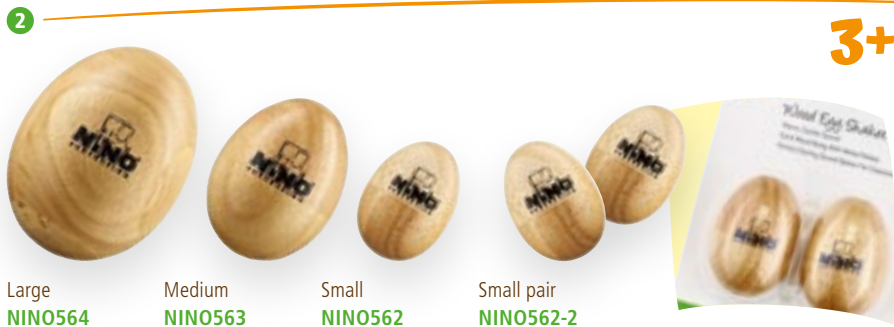

Large
NINO564

Medium
NINO563

Small
NINO562

Small pair
NINO562-2



Aubergine
NINO540AU-2

Sky Blue
NINO540SB-2

Grass Green
NINO540GG-2

Yellow
NINO540Y-2

Orange
NINO540OR-2

Red
NINO540R-2

Strawberry Pink
NINO540SP-2

Black
NINO540BK-2

Transparent
NINO540T-2



Set, 4 pcs.
NINOSET540



Set, 4 pcs.
NINOSET540-2

Set, 80 pcs.
VE80-NINO540

Set, 80 pcs.
VE80-NI540-2

1 RAWHIDE EGG SHAKER

MATERIAL Natural rawhide

2 WOOD EGG SHAKERS

SIZES NINO562: Small
NINO563: Medium
NINO564: Large

MATERIAL Siam Oak (*Hevea brasiliensis* Muell.-Arg.)

FEATURE NINO562-2: Sold in pairs

3 EGG SHAKER PAIRS

MATERIAL Plastic

FEATURE Sold in pairs

COLOURS AU: Aubergine

BK: Black

GG: Grass Green

OR: Orange

R: Red

SB: Sky Blue

SP: Strawberry Pink

T: Transparent

Y: Yellow

4 EGG SHAKER ASSORTMENTS, 4 PCS.

MATERIAL Plastic

CONTAINS NINOSET540

1 x Egg Shaker, Blue (B)

1 x Egg Shaker, Green (GR)

1 x Egg Shaker, Red (R)

1 x Egg Shaker, Yellow (Y)

NINOSET540-2

1 x Egg Shaker, Aubergine (AU)

1 x Egg Shaker, Grass Green (GG)

1 x Egg Shaker, Orange (OR)

1 x Egg Shaker, Sky Blue (SB)

5 EGG SHAKER ASSORTMENTS, 80 PCS.

MATERIAL Plastic

CONTAINS VE80-NINO540

25 x Egg Shaker, Black (BK)

15 x Egg Shaker, Blue (B)

10 x Egg Shaker, Green (GR)

15 x Egg Shaker, Red (R)

15 x Egg Shaker, Yellow (Y)

VE80-NI540-2

10 x Egg Shaker, Aubergine (AU)

10 x Egg Shaker, Black (BK)

10 x Egg Shaker, Grass Green (GG)

10 x Egg Shaker, Orange (OR)

10 x Egg Shaker, Red (R)

10 x Egg Shaker, Sky Blue (SB)

10 x Egg Shaker, Strawberry Pink (SP)

10 x Egg Shaker, Yellow (Y)

INCLUDES 1 x Elephant shaped rattan basket

"FRUIT & VEGETABLE" SHAKERS

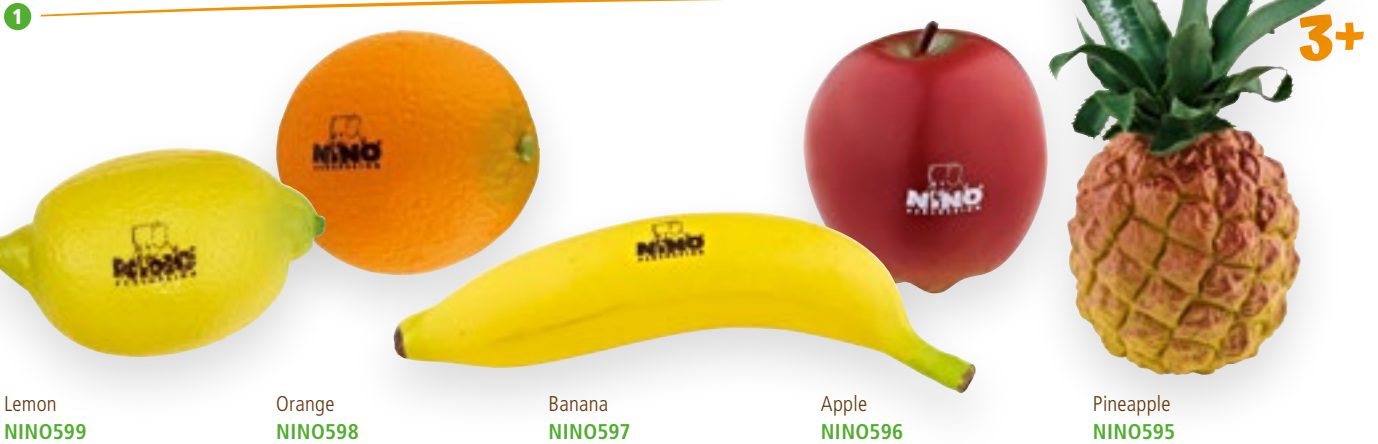

Lemon
NINO599

Orange
NINO598

Banana
NINO597

Apple
NINO596

Pineapple
NINO595



Set, 4 pcs.
NINOSET100



Set, 4 pcs.
NINOSET101



Set, 36 pcs.
VE36-NINO536

1 "FRUIT" SHAKERS

- MATERIAL** Plastic
FRUITS NINO595: Pineapple
 NINO596: Apple
 NINO597: Banana
 NINO598: Orange
 NINO599: Lemon

2 "FRUIT" SHAKER ASSORTMENT, 4 PCS.

- MATERIAL** Plastic
CONTAINS 1 x "Fruit" Shaker, Apple
 1 x "Fruit" Shaker, Banana
 1 x "Fruit" Shaker, Lemon
 1 x "Fruit" Shaker, Orange

3 "VEGETABLE" SHAKER ASSORTMENT, 4 PCS.

- MATERIAL** Plastic
CONTAINS 1 x "Vegetable" Shaker, Carrot
 1 x "Vegetable" Shaker, Cucumber
 1 x "Vegetable" Shaker, Eggplant
 1 x "Vegetable" Shaker, Pepper

4 "FRUIT & VEGETABLE" SHAKER ASSORTMENT, 36 PCS.

- MATERIAL** Plastic
CONTAINS Two sets, each 18 pcs.:
 10 x "Fruit" Shaker, Banana
 4 x "Fruit" Shaker, Apple
 4 x "Fruit" Shaker, Orange
 2 x "Fruit" Shaker, Lemon
 2 x "Fruit" Shaker, Mandarin
 2 x "Fruit" Shaker, Pear
 2 x "Fruit" Shaker, Pineapple
 2 x "Vegetable" Shaker, Cabbage
 2 x "Vegetable" Shaker, Carrot
 2 x "Vegetable" Shaker, Cucumber
 2 x "Vegetable" Shaker, Eggplant
 2 x "Vegetable" Shaker, Pepper
INCLUDES 2 x Rattan basket

SHAKERS

1



NINO526



Shake the pieces and find a pair that sounds the same!
The photos on the bottom show you if they are correct.

3+

2



NINO956

3+

3



Blue
NINO576B

Green
NINO576GR

Orange
NINO576OR

Red
NINO576R

3+

4



NINO501

3+

5



Large
NINO502

Small
NINO501

Set, 3 pcs.
NINO507

Set, 3 pcs.
NINO508

3+

6



Set, 2 pcs.
NINO578

3+

7



Blue
NINO955B

Green
NINO955GR

Red
NINO955R

3+

8



NINO509

3+

9



NINO577

3+

1 SHAKE 'N PLAY

MATERIALS Plastic shakers
Siam Oak baseplate
(*Hevea brasiliensis* Muell.-Arg.)

CONTAINS 16 shakers (8 pairs)
Wooden baseplate
Game guide (in 8 languages)

COLOUR Orange

COLOURS B: Blue
GR: Green
OR: Orange
R: Red

4 CAXIXI

MATERIAL Rattan with natural hide bottom

5 WOOD SHAKERS

SHAPES NINO1: Cylindrical, small
NINO2: Cylindrical, large
NINO507: Square, 3 pcs. set
NINO508: Triangular, 3 pcs. set

MATERIAL Siam Oak (*Hevea brasiliensis* Muell.-Arg.)
FEATURE Different sounding fillings

6 "SALT & PEPPER" SHAKERS

MATERIAL Plastic
FEATURES Different sounding fillings
Durable construction

7 MINI CAJON SHAKERS

MATERIAL Baltic Birch (*Betula pendula*)
FEATURES Compact size
Cutting shaker sound
Miniature size of a NINO® cajon

COLOURS B: Blue
GR: Green
R: Red

8 BALL SHAKER

MATERIAL Plastic
FEATURE Attractive Harlekin design

9 DOUBLE SHAKER

SIZE 6"
MATERIAL Plastic
FEATURE Ergonomically shaped handle
One-handed playable

MARACAS



Sky Blue
NINO569SB

Grass Green
NINO569GG



Orange
NINO569OR



Red
NINO569R



Set, 48 pcs.
VE48-NINO569



NINO565



Green
NINO582GR



Yellow
NINO582Y



Red
NINO582R



Red
NINO8PD-R

Blue
NINO7PD-B



NINO8

NINO7



NINO10

1 PLASTIC EGG MARACAS

SIZE 6"
MATERIAL Plastic
FEATURES Ergonomically shaped handle
Sold in pairs
COLOURS **GG:** Grass Green
OR: Orange
R: Red
SB: Sky Blue

2 PLASTIC EGG MARACAS ASSORTMENT, 48 PCS.

MATERIAL Plastic
CONTAINS 12 x Plastic Egg Maraca, Grass Green (GG)
12 x Plastic Egg Maraca, Orange (OR)
12 x Plastic Egg Maraca, Red (R)
12 x Plastic Egg Maraca, Sky Blue (SB)
INCLUDES 1 x Rattan basket

3 WOOD EGG MARACAS

SIZE Small
MATERIAL Siam Oak (*Hevea brasiliensis* Muell.-Arg.)
FEATURES Ergonomically shaped handle
Sold in pairs

4 PLASTIC MARACAS

MATERIAL Plastic
FEATURES Ergonomically shaped handle
Sold in pairs
COLOURS **GR:** Green
R: Red
Y: Yellow

5 WOOD MARACAS

SIZES **NINO7, NINO7PD-B:** Small
NINO8, NINO8PD-R: Medium
MATERIAL Siam Oak (*Hevea brasiliensis* Muell.-Arg.)
FEATURES Ergonomically shaped handle
Sold in pairs
COLOURS **PD-B:** Blue with white polka dots
PD-R: Red with white polka dots

6 RAWHIDE MARACAS

SIZE Small
MATERIAL Natural rawhide
FEATURES Mellow sound
Ergonomically shaped wood handle
Sold in pairs

HAND PERCUSSION



1 SAND BLOCKS

MATERIAL Pine Wood (*Pinus Radiata*)
FEATURES Sold in pairs
 Unique sounds
COLOURS **B:** Blue
GR: Green
R: Red

2 SYNTHETIC RAINSTICKS

SIZES **NINO-SRS1-M:** 18"
NINO-SRS1-L: 24"
MATERIAL Lightweight synthetic
FINISH Sunshine

3 WOOD RAINMAKER

SIZE 12" long
MATERIAL Baltic Birch (*Betula Pendula*)
FEATURES Birch wood construction with rounded corners
 Authentic rain sounds with a long sustain

4 WOOD HAND CASTANET

MATERIAL Siam Oak (*Hevea brasiliensis* Muell.-Arg.)
FEATURE Attractive shape

5 WOODPECKER

MATERIAL Siam Oak (*Hevea brasiliensis* Muell.-Arg.)

6 WOOD FROG GÜIROS

SIZES **NIN0517:** X-Small 2 1/4"
NIN0513GR: Small 4"
NIN0514GR: Medium 5"
NIN0515GR: Large 5 1/2"
NIN0516GR: X-Large 8 1/2"

MATERIAL Wood
FEATURE Creates original "ribbit" sound
INCLUDES Wooden scraper
COLOUR **GR:** Green

7 MINI GÜIROS

SIZE Mini
INCLUDES Wooden scraper
COLOUR **BK:** Black
R: Red

8 WOOD GÜIRO

MATERIAL Siam Oak (*Hevea brasiliensis* Muell.-Arg.)
INCLUDES Wooden scraper

9 WOOD GÜIRO SHAKER

MATERIAL Siam Oak (*Hevea brasiliensis* Muell.-Arg.)
FEATURE Additional shaker sound
INCLUDES Wooden scraper

10 4+



NINO557

11 3+



NINO556

12 3+

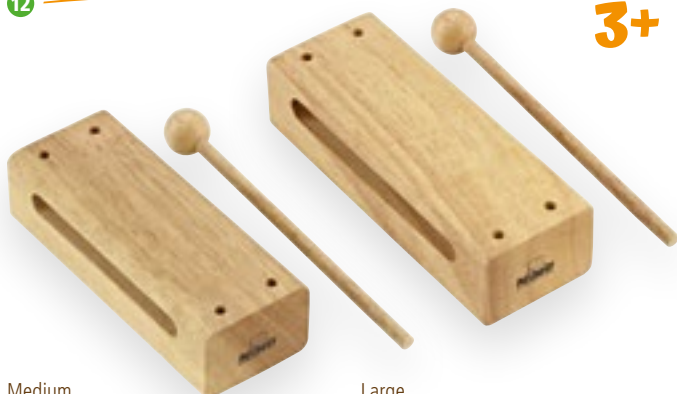

Medium
NINO21

Large
NINO22

13 3+



Large
NINO571

Medium
NINO570

14 3+



2 rows
NINO560

3 rows
NINO561

15 3+



NINO9

16 3+



NINO970

NINO971

10 WOOD BALL STIRRING DRUM

MATERIAL Siam Oak (*Hevea brasiliensis* Muell.-Arg.)
FEATURE Ergonomically shaped handle

11 WOOD STIRRING DRUM

MATERIAL Siam Oak (*Hevea brasiliensis* Muell.-Arg.)
FEATURE Ergonomically shaped handle
INCLUDES Wooden beater

12 WOOD BLOCKS

SIZES NINO21: Medium
NINO22: Large
MATERIAL Siam Oak (*Hevea brasiliensis* Muell.-Arg.)
INCLUDES Wooden beater

13 WOOD TONE BLOCKS

SIZES NINO570: Medium
NINO571: Large
MATERIAL Siam Oak (*Hevea brasiliensis* Muell.-Arg.)
FEATURE Tonally matched resonating bodies
INCLUDES Wooden beater

14 WOOD A-GO-GO'S

SIZES NINO560: 2 rows
NINO561: 3 rows
MATERIAL Siam Oak (*Hevea brasiliensis* Muell.-Arg.)
FEATURES Different playing options
Ergonomically shaped handle
INCLUDES Wooden beater

15 WOOD BEATER

MATERIAL Siam Oak (*Hevea brasiliensis* Muell.-Arg.)
FEATURE Can be used for most percussion instruments

16 PERCUSSION MALLETS

SIZE 10" long
MATERIALS White Beech
NINO970: Natural felt
NINO971: Rubber
FEATURES Great to use with woodblocks, hand drums, and other commonly found percussion instruments
Extremely versatile and durable
Different options for sound and touch
Made of white beech
Made in Germany
NINO970: Big felt head, medium hard
NINO971: Small rubber head, medium hard

HAND PERCUSSION



1 JINGLE STICKS

MATERIALS ABS plastic frame
Nickel Silver plated steel jingles

FEATURES Ergonomically shaped handle
New sound ideas

COLOURS **BK:** Black
R: Red
Y: Yellow

2 SLEIGH BELL

SIZE 4 bells

MATERIALS Wooden handle
Steel bells

FEATURES Ergonomic grip
True sleigh bell sound

3 BELL STICK

SIZE 5" long

MATERIALS Wooden handle
Steel bell

FEATURES Ergonomically shaped handle
Bell mounted on stick

4 DOUBLE BELL STICK

SIZE 6" long

MATERIALS Wooden handle
Steel bells

FEATURES Ergonomically shaped handle
Steel bells mounted on each end

5 WRIST BELLS

SIZE 3 bells
9" strap

MATERIALS Nylon strap
Steel bells

FEATURE Hook and loop fastener

COLOURS **B:** Blue
GR: Green
R: Red

6 WOOD CLAVES

SIZES **NINO502:** Small
NINO574: Regular

MATERIAL Siam Oak (*Hevea brasiliensis* Muell.-Arg.)

FEATURE Sold in pairs

7 MULTI-COLOURLED CLAVE PACK

SIZE Small

MATERIAL Siam Oak (*Hevea brasiliensis* Muell.-Arg.)

FEATURES 6 multi-coloured pairs of small wood claves
Classic clave sounds
Blends well with other instruments

8 CABASAS

SIZES **NINO701:** Small
NINO702: Medium

MATERIALS Beech Wood
Steel chain and cylinder

FEATURE Ergonomically shaped wooden handle



3 rows
NINO580



Large
NINO579L



Medium
NINO579M



Small
NINO579S



NINO901



NINO902



NINO602R



g#, c', f', f'', c'''
NINO963GR

c', c', a', a, f', e', e''
NINO964R

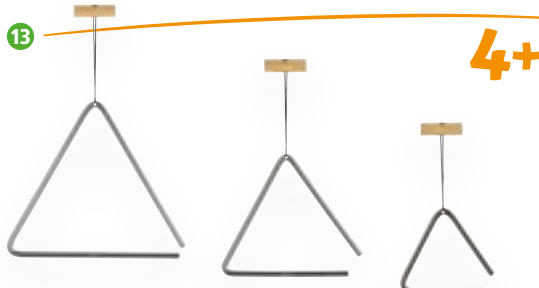

8"
NINO552

6"
NINO551

4"
NINO550



NINO567



NINO505



NINO600

8 ENERGY CHIMES

SIZES NINO579S: Small
NINO579M: Medium
NINO579L: Large
NINO580: 3 rows

MATERIAL Silver anodized aluminum alloy
INCLUDES Wooden beater

9 GLOCKENSPIEL

TONES c, d, e, f, g, a, b, c
MATERIALS Pine Wood body
Removable colour-coded metal keys
INCLUDES Two wooden mallets
Songbook
FINISH Matte

10 C MAJOR SCALE GLOCKENSPIEL

TONES c3, d3, e3, f-sharp3, g3, a3, b-flat3, b3, c4, d4, e4, f4, f3

MATERIALS Wooden body
Removable steel keys
INCLUDES Two wooden mallets
FINISH Matte

11 WAH-WAH TUBE

MATERIAL Anodized aluminum
INCLUDES Wooden stick with rubber beater
COLOUR R: Red

12 WOOD KALIMBAS

TONES NINO963GR: g#, c', f', f'', c'''
NINO964R: c', c', a', a, f', e', e''
MATERIALS Radiata Pine (*Pinups Radiata*)
Chrome plated steel keys
FEATURES Solid wood construction
Light and pleasant sound
COLOURS GR: Green
R: Red

13 TRIANGLES

SIZES NINO550: 4"
NINO551: 6"
NINO552: 8"

MATERIALS Steel
INCLUDES Metal beater with rubber padded grip

14 TRIANGLE BEATER

MATERIAL Steel

15 A-GO-GO BELL

MATERIAL Black powder coated steel
INCLUDES Wooden beater

16 CHIMES

SIZE 12 bars
MATERIAL Silver anodized aluminum alloy

STEEL TONGUE DRUMS & CYMBALS

1



Red
NINO980R

NEW

5+



White
NINO980WH



2



Brass, 8"
NINO-BR20



Bronze, 8"
NINO-BO20



FX9, 8"
NINO-NS20



FX9, 7"
NINO-NS18

5+

3



FX9, 14"
NINO-NS355



FX9, 12"
NINO-NS305



5+

4



For 7", 8"
BR4

For 12", 14"
BR6

1 MINI MELODY STEEL TONGUE DRUMS

SIZE 5.5"
MATERIAL Steel
TUNING C5, D5, E5, G5, A5, C6
FEATURES Miniature size Steel Tongue Drum
Play any melody without wrong notes
Great for classrooms or to play at home for fun
Pre-tuned scale
Creates a soothing and tranquil tone

INCLUDES Bag
Rubber mallet pair

COLOURS **R:** Red
WH: White

2 CYMBAL PAIRS

SIZES **NINO-NS18:** 7"
NINO-BO20, NINO-BR20, NINO-NS20: 8"

MATERIALS **NINO-BO20:** B8 bronze alloy
NINO-BR20: MS63 brass alloy
NINO-NS18, NINO-NS20: FX9 alloy

INCLUDES Leather strap (BR4)

3 CYMBALS

SIZES **NINO-NS305:** 12"
NINO-NS355: 14"

MATERIAL FX9 alloy

INCLUDES Leather strap (BR6)

4 LEATHER STRAPS

SIZES **BR4:** For 7" and 8" cymbals
BR6: For 12" and 14" cymbals

MATERIAL Leather

FEATURES Easily hold the cymbals in the traditional marching grip
BR4: Sold in pairs

NINO® CYMBALS "MADE IN GERMANY"

The NINO® cymbals and cymbal pairs made out of valuable materials provide the best sound at an unbeatable price. The best possible sound and consistency is a result of our state-of-the-art cymbal manufacturing facility located in Germany.



HOW TO PLAY

CAJONS

1. Leaning over and hitting the cajon with your palm toward the middle of the front plate will produce a low end tone.
2. Slapping the cajon on the side or near the top will produce a high pitched tone.
3. Use your foot for a special playing technique.
4. Tilting the cajon makes it more comfortable on your back and wrists.



DJEMBES

1. Place the djembe between your legs, crossing your ankles in front of you for support. Keeping your hands relaxed, strike the head of the drum near the edge for strong open and slap tones. Striking the drum in the middle will produce a powerful bass tone.
2. Alternating between your right and left hands, create your own patterns and rhythms.
3. Tune the djembe by using the provided tuning wrench to create a higher or lower sound.

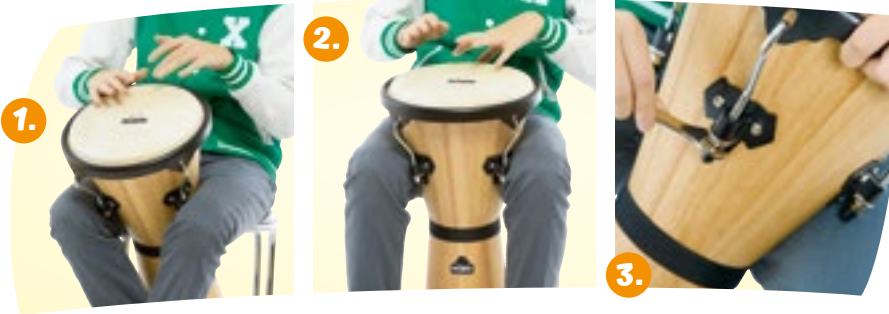

BONGOS

1. Traditionally, you play the bongo between your legs with the smaller drum on your left. A slap tone is produced by cupping your fingers slightly as you strike the head of the bongo.
2. To create an open tone, strike near the edge of the bongo head with the length of your fingers in a loose slapping motion, letting your fingers bounce as you make contact with the drum.

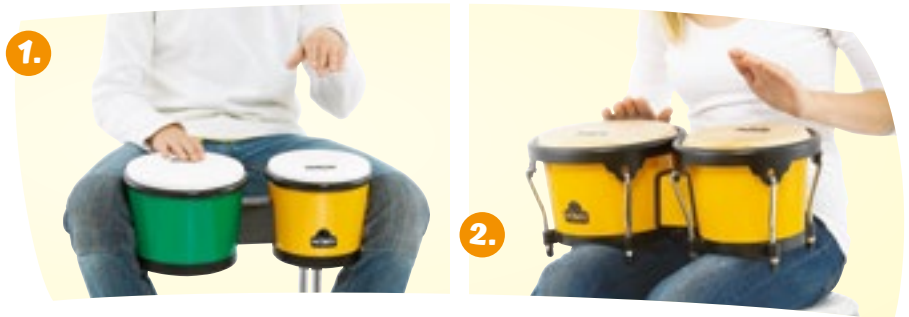

CONGAS

1. Keeping your hands relaxed, strike the head of the conga near the edge for strong open and slap tones. Striking the drum in the middle will produce a powerful bass tone.
2. Use the two congas together to create fun rhythmic and melodic patterns.
3. Tune the conga by using the provided tuning wrench to create a higher or lower sound.

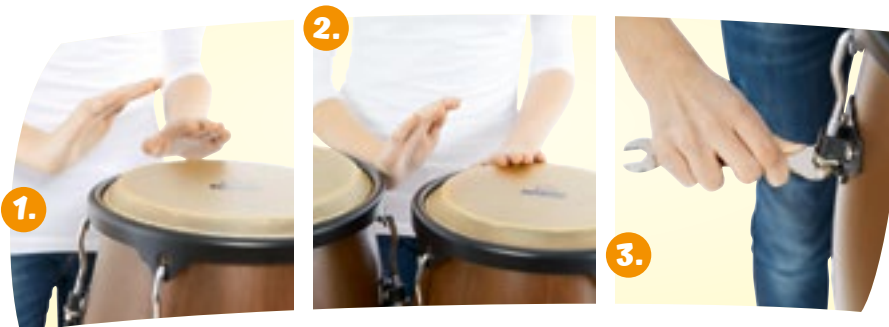

SEA DRUMS

1. Hold the sea drum horizontally and turn the drum slowly to create the sound of waves flowing in the sea.
2. Striking the sea drum in a horizontal position will create a crashing waves sound.
3. Holding the drum vertical and striking the heads will create a more traditional drum sound with some added rattle for a variety of interesting effects.





Meinl Sonic Energy is a collection of instruments that supports our connection to experience the body, mind and energy, as One. Many practitioners and guides within the health and wellness industry use these instruments therapeutically for stress management, anxiety relief, insomnia, depression, addictive recovery, pain management, etc. They are unique expressions of the vibrations we encounter on a daily basis and when listened to closely, seem to have a language all their own. They invite us to appreciate the definition of all things we find harmonious in our life and through this support, our journey begins toward new peace and restoration. Our collection of beautifully crafted creations makes self-discovery through sound a simple, profound practice.

- Kalimbas 02
- Singing Bowls 04
- Singing Bowl Accessories 08
- Crystal Singing Bowls 10
- Crystal Singing Bowl Accessories 12
- Crystal Tuning Forks 13
- Tuning Forks 14
- Tuning Fork Accessories 15
- Therapy Tuning Forks 16
- Therapy Tuning Fork Accessories 17
- Gongs 18
- Flower of Life Collection 20
- Gong Stands 21
- Gong Mallets & Beaters 22
- Gong Accessories 23
- Energy Chimes 24
- Metal Effects 25
- Handpans 26
- Handpan Accessories 28
- Steel Tongue Drums 29
- Sound Effects 30
- Frame Drums 32



KALIMBAS

1 NEW



17 notes, Maple & Acacia
KL1706H



17 notes, Acacia
KL1707H



17 notes, Mahogany
KL1708H

2 NEW



17 notes, Acacia
KL1705H



17 notes, Maple
KL1709H

3 NEW



8 notes, Sapele
KL8MINI



1 SOUND HOLE KALIMBAS

SIZE 5.3" W x 1.3" H x 7.3" D
MATERIALS Chrome plated steel
KL1706H: Maple, Acacia
KL1707H: Acacia
KL1708H: Mahogany
KL1709H: Maple
TUNING C Major
 d¹, b¹, g¹, e¹, c¹, a, f, d, c, e, g, b, d², f², a², c², e² (17 notes)
FEATURES Hollowed resonating body
 Harmonious tone sequence
INCLUDES Case; Cotton bag; Microfiber cloth; Tuning hammer
FINISH **KL1706H, KL1707H, KL1709H:** Gloss
KL1708H: Matte

2 WAH-WAH KALIMBA

SIZE 5.3" W x 1.3" H x 7.3" D
MATERIALS Chrome plated steel
 Acacia
TUNING C Major
 d¹, b¹, g¹, e¹, c¹, a, f, d, c, e, g, b, d², f², a², c², e² (17 notes)
FEATURES Hollowed resonating body
 Harmonious tone sequence
 Wah-wah effect
INCLUDES Case; Cotton bag; Microfiber cloth; Tuning hammer
FINISH Gloss

3 MINI KALIMBA

SIZE 2.0" W x 0.7" H x 2.8" D
MATERIALS Chrome plated steel
 Sapele
TUNING C Major
 c¹, a, f, d, c, e, g, b¹ (8 notes)
FEATURES Solid body
 Harmonious tone sequence
 Excellent gift idea
INCLUDES Ribbon
FINISH Gloss

4 NEW



21 notes, Black Walnut
KL2101S



17 notes, Black Walnut
KL1701S



17 notes, Sapele
KL1702S



17 notes, Acacia
KL1703S



17 notes, Maple
KL1704S



8 notes, Maple
KL801S



4 SOLID KALIMBAS

- SIZES**
- KL2101S:** 5.5" W x 0.9" H x 7.1" D
 - KL1701S:** 5.4" W x 0.8" H x 7.5" D
 - KL1702S:** 5.2" W x 0.8" H x 7.3" D
 - KL1703S:** 5.1" W x 0.8" H x 7.1" D
 - KL1704S:** 5.1" W x 0.8" H x 7.1" D
 - KL801S:** 2.8" W x 0.8" H x 4.3" D
- MATERIALS**
- Chrome plated steel
 - KL2101S, KL1701S:** Black Walnut
 - KL1702S:** Sapele
 - KL1703S:** Acacia
 - KL1704S, KL801S:** Maple

- TUNING**
- C Major
 - KL2101S:** d¹, b¹, g¹, e¹, c¹, a, f, d, B, G, F, A, c, e, g, b, d, f, a¹, c¹, e¹ (21 notes)
 - KL1701S, KL1702S, KL1703S, KL1704S:** d¹, b¹, g¹, e¹, c¹, a, f, d, c, e, g, b, d¹, f¹, a¹, c¹, e¹ (17 notes)
 - KL801S:** a¹, e¹, c¹, g, a, d¹, g¹, c¹ (8 notes)
- FEATURES**
- Solid body
 - Harmonious tone sequence
- INCLUDES**
- Cotton bag; Microfiber cloth; Tuning hammer
 - KL2101S, KL1701S, KL1702S, KL1703S, KL1704S:** Case
- FINISH**
- Gloss

SINGING BOWLS

1



5.1"
SB-O-600



5.7"
SB-O-700



6.7"
SB-O-900

2



Set, 3 pcs.
SB-O-2200

3



4.5"
SB-U-400



4.9"
SB-U-500



5.5"
SB-U-600



5.9"
SB-U-700



6.5"
SB-U-750

SHAPE



4



Set, 2 pcs.
SB-U-900



Set, 3 pcs.
SB-U-1500



Set, 4 pcs.
SB-U-1750



Set, 3 pcs.
SB-U-1950



Set, 5 pcs.
SB-U-2950

1 ORIGIN SERIES SINGING BOWLS

DIMENSIONS **SB-O-600:** ~5.1" diameter; ~600 g
SB-O-700: ~5.7" diameter; ~700 g
SB-O-900: ~6.7" diameter; ~900 g

MATERIAL Special bronze alloy

FEATURES Ideal for yoga and meditation
Handcrafted masterpiece made in India
Engraved logo on the bottom

INCLUDES Corresponding cover and felt ring

2 ORIGIN SERIES SINGING BOWL SET

CONTAINS SB-O-600, SB-O-700, SB-O-900

INCLUDES Corresponding covers and felt rings
Mallet (SB-M-ST-L)

3 UNIVERSAL SERIES SINGING BOWLS

DIMENSIONS **SB-U-400:** ~4.5" diameter; ~400 g
SB-U-500: ~4.9" diameter; ~500 g
SB-U-600: ~5.5" diameter; ~600 g
SB-U-700: ~5.9" diameter; ~700 g
SB-U-750: ~6.5" diameter; ~750 g

MATERIAL Special bronze alloy

FEATURES Ideal for yoga and meditation
Handcrafted masterpiece made in India
Engraved logo

INCLUDES Corresponding cover and felt ring

4 UNIVERSAL SERIES SINGING BOWL SETS

CONTAINS **SB-U-900:** SB-U-400, SB-U-500

SB-U-1500: SB-U-400, SB-U-500, SB-U-600

SB-U-1750: SB-U-400, SB-U-500, SB-U-600, SB-C-250

SB-U-1950: SB-U-500, SB-U-700, SB-U-750

SB-U-2950: SB-U-400, SB-U-500, SB-U-600, SB-U-700, SB-U-750

INCLUDES Corresponding covers and felt rings
Resonant Mallet (SB-RM-LE)

SB-U-2950: Mallet (SB-M-LT-S)

5



6.4"
SB-E-700



7.8"
SB-E-1000



9.0"
SB-E-1400



10.2"
SB-E-1800



11.4"
SB-E-2200



12.2"
SB-E-2500

6



Set, 3 pcs.
SB-E-3100

Therapy
Basis Set



Set, 3 pcs.
SB-E-4600



Set, 3 pcs.
SB-E-5400



5 ENERGY THERAPY SERIES SINGING BOWLS

DIMENSIONS SB-E-700: ~6.4" diameter; ~700 g
SB-E-1000: ~7.8" diameter; ~1000 g
SB-E-1400: ~9.0" diameter; ~1400 g
SB-E-1800: ~10.2" diameter; ~1800 g
SB-E-2200: ~11.4" diameter; ~2200 g
SB-E-2500: ~12.2" diameter; ~2500 g

MATERIAL Special bronze alloy
FEATURES Ideal for upper body sound massage
Reinforcement rim that will produce a high tone at first followed afterwards by a deep tone
Handcrafted masterpiece made in India
Engraved logo

INCLUDES Corresponding cover and felt ring

6 ENERGY THERAPY SERIES SINGING BOWL SETS

CONTAINS SB-E-3100: SB-E-700, SB-E-1000, SB-E-1400
SB-E-4600: SB-E-1000, SB-E-1400, SB-E-2200
SB-E-5400: SB-E-1400, SB-E-1800, SB-E-2200

INCLUDES Corresponding covers and felt rings
SB-E-3100: Resonant Mallet (SB-RM-LE), Mallet (SB-M-ST-L)
SB-E-4600: Professional Mallets (SB-PM-MF-S, SB-PM-MF-L)
SB-E-5400: Resonant Mallet (SB-RM-LE), Mallets (SB-M-LT-L, SB-M-ST-L)

SINGING BOWLS

1



3.7"
SB-C-250

5.8"
SB-C-650

6.6"
SB-C-800

7.6"
SB-C-1000

9.0"
SB-C-1500

2



10.3"
SB-C-2000

11.5"
SB-C-2500



Set, 4 pcs.
SB-C-2700



Set, 3 pcs.
SB-C-3800



Set, 4 pcs.
SB-C-4750

3



Set, 7 pcs.
SB-SET-CHA

1 COSMOS THERAPY SERIES SINGING BOWLS

DIMENSIONS **SB-C-250**: ~3.7" diameter; ~250 g
SB-C-650: ~5.8" diameter; ~650 g
SB-C-800: ~6.6" diameter; ~800 g
SB-C-1000: ~7.6" diameter; ~1000 g
SB-C-1500: ~9.0" diameter; ~1500 g
SB-C-2000: ~10.3" diameter; ~2000 g
SB-C-2500: ~11.5" diameter; ~2500 g

MATERIAL Special bronze alloy

FEATURES Ideal for yoga and meditation
 Generates a sustained deep tone that will fill a room with ambient sounds
 Handcrafted masterpiece made in India
 Engraved logo

INCLUDES Corresponding cover and felt ring

2 COSMOS THERAPY SERIES SINGING BOWL SETS

CONTAINS **SB-C-2700**: SB-C-250, SB-C-650, SB-C-800, SB-C-1000
SB-C-3800: SB-C-800, SB-C-1000, SB-C-2000
SB-C-4750: SB-C-250, SB-C-1000, SB-C-1500, SB-C-2000

INCLUDES Corresponding covers and felt rings
SB-C-2700: Resonant Mallet (SB-RM-LE), Mallet (SB-M-LT-S)
SB-C-3800: Professional Mallets (SB-PM-MF-S, SB-PM-MF-L)
SB-C-4750: Resonant Mallet (SB-RM-LE), Mallets (SB-M-LT-L, SB-M-ST-L)

3 SINGING BOWL CHAKRA SET

CONTAINS SB-C-250, SB-E-700, SB-E-1000, SB-E-1400, SB-C-1500, SB-E-1800, SB-E-2200,

INCLUDES Corresponding covers and felt rings
 Mallets (SB-M-LT-L, SB-M-ST-L, SB-M-ST-S, SB-M-LT-S)
 Professional Mallet (SB-PDM-F-XL)



5.35"
SB-SE-600

6.7"
SB-SE-800

8.0"
SB-SE-1000



Set, 3 pcs.
SB-SE-2400



Flower of Life, 7.6"
SB-S-FOL-1000

Venus Flower, 7.6"
SB-S-VF-1000



15.75"
SB-G-5000



21.26"
SB-G-10000



21.26"
SB-G-12000



22.05"
SB-G-13000



24.0"
SB-G-14000

4 SPECIAL ENGRAVED SERIES SINGING BOWLS

DIMENSIONS **SB-SE-600**: ~5.35" diameter; ~600 g
SB-SE-800: ~6.7" diameter; ~800 g
SB-SE-1000: ~8.0" diameter; ~1000 g

MATERIAL Special bronze alloy
FEATURES Perfect combination of a pleasing sound and look
Handcrafted masterpiece made in India
Brilliant finish
Hand-engraved ornamental design
Engraved logo
INCLUDES Corresponding cover and felt ring

5 SPECIAL ENGRAVED SERIES SINGING BOWL SET

CONTAINS SB-SE-600, SB-SE-800, SB-SE-1000
INCLUDES Corresponding covers and felt rings
Resonant Mallet (SB-RM-LE)
Mallet (SB-M-LT-S)

6 SYNTHESIS SERIES SINGING BOWLS

DIMENSIONS ~7.6" diameter; ~1000 g
MATERIAL Special bronze alloy
FEATURES Ideal for meditation, sound therapy, concerts and yoga
Generates a sustained deep tone that will fill a room with ambient sounds
Handcrafted masterpiece made in India
Engraved logo
INCLUDES Corresponding cover and felt ring
SYMBOLS **FOL**: Flower of Life
VF: Venus Flower

7 GIANT SERIES

DIMENSIONS **SB-G-5000**: ~15.75" diameter; ~5000 g
SB-G-10000: ~21.26" diameter; ~10000 g
SB-G-12000: ~21.26" diameter; ~12000 g
SB-G-13000: ~22.05" diameter; ~13000 g
SB-G-14000: ~24.0" diameter; ~14000 g
MATERIAL Special bronze alloy
FEATURES Ideal for sound therapy and can also be used for a full body experience by standing in these bowls
Handcrafted masterpiece made in India
Engraved logo
INCLUDES Corresponding buckwheat cushion
SB-G-14000: Professional Mallet (SB-PM-XXL)

SINGING BOWLS & ACCESSORIES

1 NEW



Set, 3 pcs.
SBZ1

2 NEW



Set, 3 pcs.
SBZ2

3



3.74"
SB-OR-300-BK



3.74"
SB-OR-300-R

4



4.33"
SB-OM-300



4.13"
SB-OR-400-BK



4.13"
SB-OR-400-R

5



Small
SB-ST-S

Large
SB-ST-L

1 ZEN SINGING BOWL SET

SIZES 2.8"; 3.5"; 3.9" diameter
MATERIAL Special cast alloy
FEATURES High and clear tone
Perfect for ending meditations
INCLUDES Felt coasters; Cloth bags; Mallet

2 ZEN HANGING BELL SET

SIZES 2.8"; 3.5"; 3.9" diameter
MATERIAL Special cast alloy
FEATURES High and clear tone
Perfect for ending meditations
INCLUDES Cloth bags; Mallet

3 ORNAMENTAL SERIES SINGING BOWLS

DIMENSIONS SB-OR-300: ~3.74" diameter; ~300 g
SB-OR-400: ~4.13" diameter; ~400 g
MATERIAL Special cast alloy
FEATURES Hand-painted ornamental design
Great gift idea

SB-OR-300: Consistently warm, high pitched sound

SB-OR-400: Consistently warm, low pitched sound

INCLUDES Corresponding mallet and coaster

BK: Black gift box

R: Red gift box

4 OM SERIES SINGING BOWL

DIMENSIONS ~4.33" diameter; ~300 g
MATERIAL Special cast alloy
FEATURES Consistently warm, low pitched sound
Hand-painted OM design
Great gift idea
INCLUDES Corresponding mallet and ring
Gift box

5 SINGING BOWL STANDS

SIZES S: Small
L: Large

MATERIAL Birch
FEATURES Padded layer for stability
Heat-branded logo

6 MALLETS

DIMENSIONS SB-M-ST-S: Small tip; Small (8.27")
SB-M-LT-S: Large tip; Small (8.27")
SB-M-ST-L: Small tip; Large (12.44")
SB-M-LT-L: Large tip; Large (12.44")

MATERIALS Natural felt tip
Wooden handle
FEATURE Heat-branded logo

7 RESONANT MALLETS

DIMENSIONS SB-RM: Plain; 7.91"
SB-RM-LE: Leather; 7.91"
SB-RM-LE-L: Leather; 10.24"
SB-RM-LE-XL: Leather; 10.63"
MATERIAL Wood
FEATURE Heat-branded logo



8 PROFESSIONAL MALLETS

DIMENSIONS **SB-PM-SR-S:** Soft rubber tip; Small (8.86")
SB-PM-HFS-S: Hard felt, small tip; Small (8.86")
SB-PM-HFM-S: Hard felt, medium tip; Small (8.86")
SB-PM-MF-S: Medium felt tip; Small (12.01")
SB-PM-MF-M: Medium felt tip; Medium (12.99")
SB-PM-MF-L: Medium felt tip; Large (13.78")
SB-PM-XXL: Felt tip, XX-Large (27.56")
SB-PDM-F/R-S: Double Mallet; Felt & rubber tip; Small (9.25")
SB-PDM-F-XL: Double Mallet; Felt tips; X-Large (15.94")

MATERIALS Sapele wood handle except:
SB-PM-XXL: Beech wood handle

FEATURE **SB-PDM-F-XL:** Hard maple handle
 Printed logo

9 FELT RINGS

SIZES **SB-FR-08:** 3.15" diameter
SB-FR-10: 3.94" diameter
SB-FR-13: 5.12" diameter
SB-FR-16: 6.3" diameter

MATERIAL Natural felt
FEATURE Nonslip

10 COVERS

SIZES **SB-CO-08:** 8" x 8"
SB-CO-09: 9.5" x 9.5"
SB-CO-11: 11.5" x 11.5"
SB-CO-14: 14" x 15.5"
SB-CO-17: 17" x 19"

MATERIAL Synthetic
FEATURES Prevents from dust and fingerprints;
 Printed logo

11 BUCKWHEAT CUSHIONS

SIZES **SB-BC-10:** 3.94" diameter
SB-BC-16: 6.3" diameter
SB-BC-21: 8.27" diameter
SB-BC-26: 10.24" diameter

FEATURES Filled with buckwheat
 Transferring vibrations while playing
 Embroidered logo

12 COTTON BAGS

SIZES **SB-CB-20:** 7.87" x 7.87"
SB-CB-25: 9.84" x 9.84"
SB-CB-30: 11.81" x 11.81"
SB-CB-38: 14.96" x 14.96"
SB-CB-50: 19.69" x 19.69"

MATERIALS Natural cotton linen fabric
 Synthetic fleece inlay

FEATURES Safe transport method
 Prevents from scratches
 Embroidered logo

CRYSTAL SINGING BOWLS

1 NEW



Crown Chakra, 8"
CSB8B



Heart Chakra, 8"
CSB8F



Brow Chakra, 9"
CSB9A



Throat Chakra, 10"
CSB10G



Heart Chakra, 10"
CSB10F



Navel Chakra, 10"
CSB10E



Sacral Chakra, 10"
CSB10D



Heart Chakra, 11"
CSB11F



Heart Chakra, 12"
CSB12F



Navel Chakra, 12"
CSB12E



Sacral Chakra, 12"
CSB12D



Root Chakra, 12"
CSB12C



Sacral Chakra, 13"
CSB13D



Root Chakra, 14"
CSB14C

1 CRYSTAL SINGING BOWLS

SIZES **CSB8:** 8" diameter
CSB9: 9" diameter
CSB10: 10" diameter
CSB11: 11" diameter
CSB12: 12" diameter
CSB13: 13" diameter
CSB14: 14" diameter
MATERIAL Gemstone (Quartz)

TUNING **CSB8B:** Crown Chakra, 432 Hz / Bb
CSB8F: Heart Chakra, 432 Hz / F
CSB9A: Brow Chakra, 432 Hz / A
CSB10G: Throat Chakra, 432 Hz / G
CSB10F: Heart Chakra, 432 Hz / F
CSB10E: Navel Chakra, 432 Hz / E
CSB10D: Sacral Chakra, 432 Hz / D
CSB11F: Heart Chakra, 432 Hz / F
CSB12F: Heart Chakra, 432 Hz / F
CSB12E: Navel Chakra, 432 Hz / E
CSB12D: Sacral Chakra, 432 Hz / D
CSB12C: Root Chakra, 432 Hz / C
CSB13D: Sacral Chakra, 432 Hz / D
CSB14C: Root Chakra, 432 Hz / C

FEATURES Made of high-purity quartz
White-frosted
Extremely long-lasting resonance
INCLUDES Silicone ring

2 CRYSTAL SINGING BOWL CHAKRA SET

CONTAINS CSB8B, CSB9A, CSB10G, CSB11F, CSB12E, CSB13D, CSB14C
INCLUDES 7 x Silicone Ring
Crystal Silicone Rods (CSBRM, CSBRHL)
Crystal Singing Bowl Mallet (CSBM)

3 FLOWER OF LIFE CRYSTAL SINGING BOWL & OM CRYSTAL SINGING BOWL

SIZE 8" diameter
MATERIAL Gemstone (Quartz)
TUNING 432 Hz / C#
FEATURES Made of high-purity quartz
White-frosted
Extremely long-lasting resonance
Hand engraved and hand painted
INCLUDES Silicone ring
SYMBOLS **FOL:** Flower of Life
OM: OM

2 NEW



Set, 7 pcs.
CSBSETCHA

3 NEW



Flower of Life, 8"
CSB8FOL



OM, 8"
CSB8OM

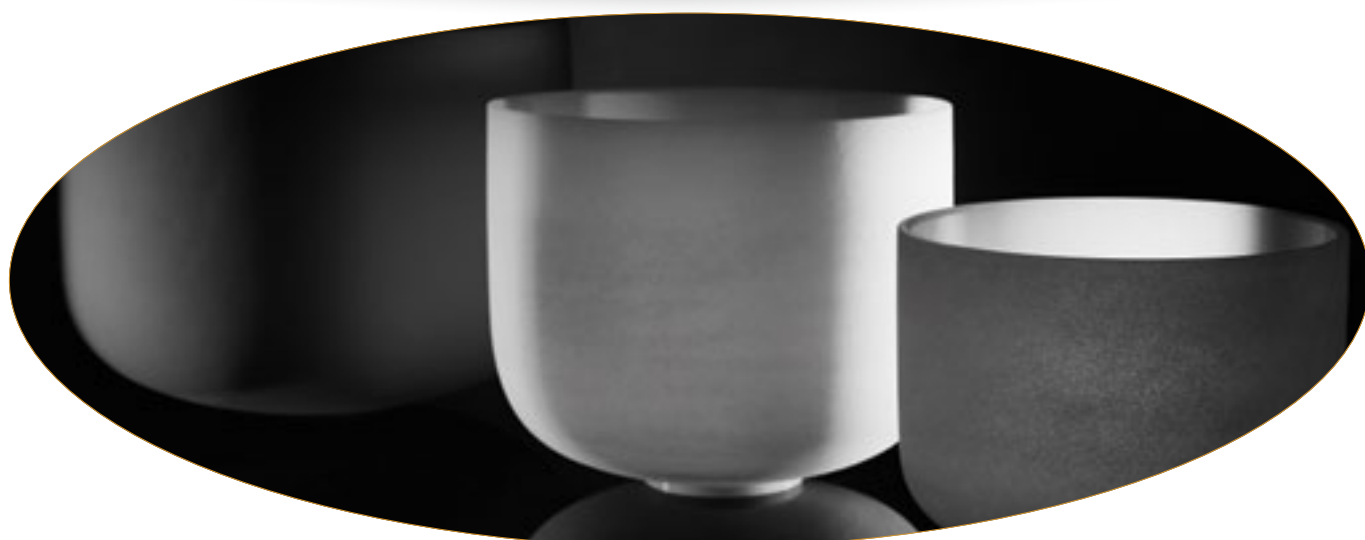

CRYSTAL SINGING BOWLS & ACCESSORIES

1 NEW



Crown Chakra, Amethyst, 8"
CSBA8B

2 NEW



Heart Chakra, Rose Quartz, 10"
CSBR10F

3 NEW



Heart Chakra, Emerald, 10"
CSBE10F

4 NEW



Medium
CSBRM Large
CSBRL



Medium
CSBRHM Large
CSBRHL



5 NEW



Mallet
CSBM

6 NEW



8"
CSBB8



10"
CSBB10



12"
CSBB12



14"
CSBB14

1 AMETHYST CRYSTAL SINGING BOWL

SIZE 8" diameter
MATERIALS Gemstones (Quartz and Amethyst)
TUNING Crown Chakra, 432 Hz / B
FEATURES Partly made of natural Amethyst
Extremely long-lasting resonance
INCLUDES Silicone ring

2 ROSE QUARTZ CRYSTAL SINGING BOWL

SIZE 10" diameter
MATERIALS Gemstones (Quartz and Rose Quartz)
TUNING Heart Chakra, 432 Hz / F
FEATURES Partly made of natural Rose Quartz
Extremely long-lasting resonance
INCLUDES Silicone ring

3 EMERALD CRYSTAL SINGING BOWL

SIZE 10" diameter
MATERIALS Gemstones (Quartz and Rose Quartz)
TUNING Heart Chakra, 432 Hz / F
FEATURES Partly made of natural Emerald
Extremely long-lasting resonance
INCLUDES Silicone ring

4 CRYSTAL SILICONE RODS

SIZES **M:** Medium (7.8")
L: Large (9.0")
MATERIALS Glass; Silicone
FEATURES Perfect for gently tapping or rubbing
crystal singing bowls
Silicone coated glass
Soft silicone facilitates nearly noiseless
rubbing
CSBRHM, CSBRHL
Glass handle for a comfortable grip

5 CRYSTAL SINGING BOWL MALLET

SIZE 7.8"
MATERIALS Wood; Rubber
FEATURES Perfect for playing crystal singing bowls
Comfortable wooden handle with a
rubber head

6 CRYSTAL SINGING BOWL BAGS

SIZES **CSBB8:** 8"
CSBB10: 10"
CSBB12: 12"
CSBB14: 14"
MATERIAL Heavy-duty padded nylon
FEATURES Safe transport method
Carrying grip
Double-slide zipper
External pocket
COLOUR Black

CRYSTAL TUNING FORKS

1 NEW



Note C, 15" length
CTF440C20



Note F, 15" length
CTF440F20



Note C, 17.7" length
CTF440C16



Note F, 17.7" length
CTF440F16

CRYSTAL



1 CRYSTAL TUNING FORKS

SIZES CTF440C20, CTF440F20:
20 mm diameter, 15" length
CTF440C16, CTF440F16:
16 mm diameter, 17.7" length

MATERIAL Gemstone (Quartz)

TUNING CTF440C: 440 Hz / C
CTF440F: 440 Hz / F

FEATURES Perfect for meditation, yoga and relaxation
Pure and attractive crystal material

PLANETARY TUNED TUNING FORKS

1 BASED ON THE CALCULATIONS OF HANS COUSTO (THE COSMIC OCTAVE)



1 PLANETARY TUNED TUNING FORKS

SIZES

- TF-CH: 7.3"
- TF-E: 8.0"
- TF-E-GEO: 7.7"
- TF-E-HY: 7.6"
- TF-E-PL: 7.4"
- TF-E-SI: 7.1"
- TF-E-SY: 7.1"
- TF-FOL: 8.3"
- TF-J: 7.2"
- TF-M-AR: 6.5"
- TF-M-CU: 7.1"
- TF-M-K: 6.6"
- TF-M-MC: 6.6"
- TF-M-SI: 6.7"
- TF-M-SP: 6.5"
- TF-M-SY: 6.9"
- TF-MA: 7.8"
- TF-ME: 7.9"
- TF-N: 6.9"

MATERIAL TUNING

Premium nickel plated steel

- CH: Chiron, 172.86 Hz / F3
- E: Earth Year/Om, 136.10 Hz / C3#
- E-GEO: Geomagnetic Field, 149.74 Hz / D3#
- E-HY: Hydrogen Gamma, 157.04 Hz / D3#
- E-PL: Platonic Year, 172.06 Hz / F3
- E-SI: Sidereal Day, 194.71 Hz / G3
- E-SY: Synodic Day, 194.18 Hz / G3
- FOL: Flower of Life, 128.00 Hz / C3
- J: Jupiter, 183.58 Hz / F3#
- M-AR: Apsidis' Rotation, 246.04 Hz / E3
- M-CU: Culmination Cycle, 187.61 Hz / F3#
- M-K: Moon Knot, 234.16 Hz / A3#
- M-MC: Metonic Cycle, 229.22 Hz / A3#
- M-SI: Sidereal Moon, 227.43 Hz / A3#
- M-SP: Saros' Period, 241.56 Hz / B3
- M-SY: Synodic Moon, 210.42 Hz / G3#
- MA: Mars, 144.72 Hz / D3
- ME: Mercury, 141.27 Hz / C3#
- N: Neptune, 211.44 Hz / G3#
- PL: Pluto, 140.64 Hz / C3#
- S: Sun, 126.22 Hz / B2 (H2)
- SA: Saturn, 147.85 Hz / D3
- SE: Sedna, 181.60 Hz / F3#
- SF: Schumann Resonance, 250.56 Hz / H3
- U: Uranus, 207.36 Hz / G3#
- V: Venus, 221.23 Hz / A3
- 256: Master Fork 2, 256.00 Hz / C3

2 NEW



Set, 2 pcs.
TF-SET-2

3



Set, 7 pcs.
TF-SET-CHA-7 / TF-SET-CHA-7C

4



Set, 16 pcs.
TF-SET-16 / TF-SET-16C

5



Set, 27 pcs.
TF-SET-27

NEW

6



Set, 21 pcs.
TF-DISPLAY

NEW

7



Natural Pitch
TF-432

Standard Pitch
TF-440

8



TFC-M

TFC-L

TFC-8

TFC-16

9



TF-HOLDER-1

TF-HOLDER-2

TF-HOLDER-7

TF-HOLDER-16

TF-HOLDER-27

2 TUNING FORK DAY AND NIGHT SET

CONTAINS TF-E, TF-E-SY
INCLUDES Tuning Fork Holder (TF-HOLDER-2)

3 TUNING FORK CHAKRA SET

CONTAINS TF-E, TF-E-PL, TF-E-SY, TF-M-SY, TF-ME, TF-S, TF-V
INCLUDES **TF-SET-CHA-7:** Tuning Fork Holder (TF-HOLDER-7)
TF-SET-CHA-7C: Tuning Fork Case (TFC-8)

4 TUNING FORK SET, 16 PCS.

CONTAINS TF-CH, TF-E, TF-E-PL, TF-E-SI, TF-E-SY, TF-J, TF-M-SI, TF-M-SY, TF-MA, TF-ME, TF-N, TF-S, TF-SA, TF-SE, TF-U, TF-V
INCLUDES **TF-SET-16:** Tuning Fork Holder (TF-HOLDER-16)
TF-SET-16C: Tuning Fork Case (TFC-16)

5 TUNING FORK SET, 27 PCS.

CONTAINS TF-CH, TF-E, TF-E-GEO, TF-E-HY, TF-E-PL, TF-E-SI, TF-E-SY, TF-FOL, TF-J, TF-M-AR, TF-M-CU, TF-M-K, TF-M-MC, TF-M-SI, TF-M-SP, TF-M-SY, TF-MA, TF-ME, TF-N, TF-PL, TF-S, TF-SA, TF-SE, TF-SF, TF-U, TF-V, TF-256
INCLUDES Tuning Fork Holder (TF-HOLDER-27)

6 TUNING FORK CHAKRA DISPLAY SET

CONTAINS TF-E, TF-E-PL, TF-E-SY, TF-M-SY, TF-ME, TF-S, TF-V (3 pcs. each)
INCLUDES Wood Display

7 NATURAL PITCH TUNING FORK & STANDARD PITCH TUNING FORK

SIZE 5.4"
MATERIAL Premium nickel plated steel
TUNING **TF-432:** 432 Hz (Natural Pitch)
TF-440: 440 Hz (Standard Pitch)

8 TUNING FORK CASES

SIZES **TFC-M:** For max. 7.1" length
TFC-L: For max. 8.3" length
TFC-8: For 8 tuning forks
TFC-16: For 16 tuning forks
MATERIALS Inner material polyester
Outer material leatherette
FEATURE For safe and easy transportation

9 TUNING FORK HOLDERS

SIZES **TF-HOLDER-1:** For 1 tuning fork
TF-HOLDER-2: For 2 tuning forks
TF-HOLDER-7: For 7 tuning forks
TF-HOLDER-16: For 16 tuning forks
TF-HOLDER-27: For 27 tuning forks
MATERIAL Beech wood

PLANETARY TUNED THERAPY TUNING FORKS

1 NEW BASED ON THE CALCULATIONS OF HANS COUSTO (THE COSMIC OCTAVE)



1 PLANETARY TUNED THERAPY TUNING FORKS

SIZES

- TTF-CH:** 8.9"
- TTF-E:** 9.6"
- TTF-E-GEO:** 9.3"
- TTF-E-HY:** 9.1"
- TTF-E-PL:** 8.9"
- TTF-E-SI:** 8.5"
- TTF-E-SY:** 8.5"
- TTF-J:** 8.7"
- TTF-M-AR:** 7.9"
- TTF-M-CU:** 8.6"
- TTF-M-K:** 8.0"
- TTF-M-MC:** 8.1"
- TTF-M-SI:** 8.1"
- TTF-M-SP:** 7.9"
- TTF-M-SY:** 8.3"
- TTF-MA:** 9.4"
- TTF-ME:** 9.4"
- TTF-N:** 8.3"

MATERIAL TUNING

- Premium nickel plated steel**
- CH:** Chiron, 172.86 Hz / F3
- E:** Earth Year/Om, 136.10 Hz / C3#
- E-GEO:** Geomagnetic Field, 149.74 Hz / D3#
- E-HY:** Hydrogen Gamma, 157.04 Hz / D3#
- E-PL:** Platonic Year, 172.06 Hz / F3
- E-SI:** Sidereal Day, 194.71 Hz / G3
- E-SY:** Synodic Day, 194.18 Hz / G3
- J:** Jupiter, 183.58 Hz / F3#
- M-AR:** Apsidis' Rotation, 246.04 Hz / E3
- M-CU:** Culmination Cycle, 187.61 Hz / F3#
- TTF-PL:** 9.4"
- TTF-S:** 9.8"
- TTF-SA:** 9.3"
- TTF-SE:** 8.7"
- TTF-SF:** 7.8"
- TTF-U:** 8.3"
- TTF-V:** 8.1"
- TTF-128:** 9.8"
- TTF-256:** 7.8"

- M-K:** Moon Knot, 234.16 Hz / A3#
- M-MC:** Metonic Cycle, 229.22 Hz / A3#
- M-SI:** Sidereal Moon, 227.43 Hz / A3#
- M-SP:** Saros' Period, 241.56 Hz / B3
- M-SY:** Synodic Moon, 210.42 Hz / G3#
- MA:** Mars, 144.72 Hz / D3
- ME:** Mercury, 141.27 Hz / C3#
- N:** Neptune, 211.44 Hz / G3#
- PL:** Pluto, 140.64 Hz / C3#
- S:** Sun, 126.22 Hz / B2 (H2)
- SA:** Saturn, 147.85 Hz / D3
- SE:** Sedna, 181.60 Hz / F3#
- SF:** Schumann Resonance, 250.56 Hz / H3
- U:** Uranus, 207.36 Hz / G3#
- V:** Venus, 221.23 Hz / A3
- 128:** Master Fork, 128.00 Hz / C3
- 256:** Master Fork 2, 256.00 Hz / C3

FEATURES

- Handcrafted masterpiece made in Germany
- Ergonomic shaped cork handle
- Engraved logo and tuning info



Set, 2 pcs.
TTF-SET-2



Set, 7 pcs.
TTF-SET-CHA-7



Set, 16 pcs.
TTF-SET-16



Set, 27 pcs.
TTF-SET-27

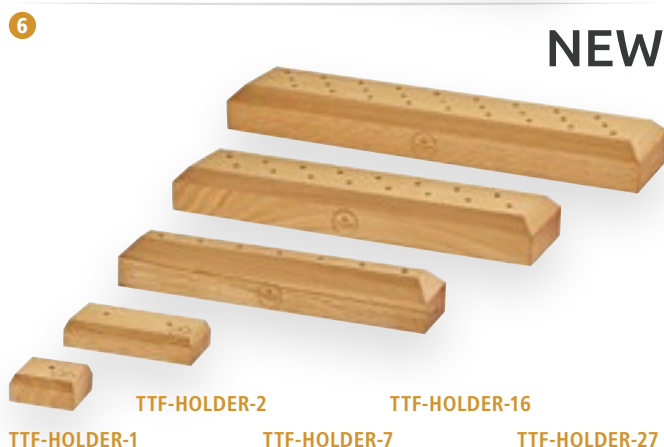

2 THERAPY TUNING FORK DAY AND NIGHT SET

CONTAINS TTF-E, TTF-E-SY
INCLUDES Therapy Tuning Fork Holder (TTF-HOLDER-2)

3 THERAPY TUNING FORK CHAKRA SET

CONTAINS TTF-E, TTF-E-PL, TTF-E-SY, TTF-M-SY, TTF-ME, TTF-S, TTF-V
INCLUDES Therapy Tuning Fork Holder (TTF-HOLDER-7)

4 THERAPY TUNING FORK SET, 16 PCS.

CONTAINS TTF-CH, TTF-E, TTF-E-PL, TTF-E-SI, TTF-E-SY, TTF-J, TTF-M-SI, TTF-M-SY, TTF-MA, TTF-ME, TTF-N, TTF-S, TTF-SA, TTF-SE, TTF-U, TTF-V
INCLUDES Therapy Tuning Fork Holder (TTF-HOLDER-16)

5 THERAPY TUNING FORK SET, 27 PCS.

CONTAINS TTF-CH, TTF-E, TTF-E-GEO, TTF-E-HY, TTF-E-PL, TTF-E-SI, TTF-E-SY, TTF-J, TTF-M-AR, TTF-M-CU, TTF-M-K, TTF-M-MC, TTF-M-SI, TTF-M-SP, TTF-M-SY, TTF-MA, TTF-ME, TTF-N, TTF-PL, TTF-S, TTF-SA, TTF-SE, TTF-SF, TTF-U, TTF-V, TTF-128, TTF-256
INCLUDES Therapy Tuning Fork Holder (TTF-HOLDER-27)

6 THERAPY TUNING FORK HOLDERS

SIZES **TTF-HOLDER-1:** For 1 tuning fork
TTF-HOLDER-2: For 2 tuning forks
TTF-HOLDER-7: For 7 tuning forks
TTF-HOLDER-16: For 16 tuning forks
TTF-HOLDER-27: For 27 tuning forks
MATERIAL Beech wood

GONGS

1 DESIGNED IN COOPERATION WITH DON CONREAUX

BACK



32" / 80 cm
G32-DC-B

2 五 = WU 行 = XING



24" / 60 cm
G24-WX

28" / 70 cm
G28-WX

32" / 80 cm
G32-WX

36" / 90 cm
G36-WX

40" / 100 cm
G40-WX

3 NEW



22" / 55 cm
IG1

4



24" / 60 cm
SY-TT24

28" / 70 cm
SY-TT28

32" / 80 cm
SY-TT32

36" / 90 cm
SY-TT36

5



12" / 30 cm
OG-12

6



12" / 30 cm
WG-12

14.5" / 37 cm
WG-145

7



12.5" / 31.5 cm
TG-125

13" / 33 cm
TG-13

14" / 36 cm
TG-14

1 DON CONREAUX EIGHT CORNERS OF HEAVEN MIRROR GONG

SIZE 32"
MATERIAL Nickelsilver
TUNING D2 - D2#
FEATURES Handcrafted masterpiece made in Germany
Exact fine tuning through hand-hammering
Printed ancient mysterious symbols on front and tuning info on the back
The eight runic glyphs represent the cycle of life
Mirror surface allows player to see himself, listeners or other gong players
INCLUDES Cover and gloves

2 WU XING GONGS

SIZES G24-WX: 24"; G28-WX: 28";
G32-WX: 32"; G36-WX: 36";
G40-WX: 40"
MATERIAL Nickelsilver

TUNING G24-WX: G2 - G2#
G28-WX: E2 - F2
G32-WX: C2# - D2
G36-WX: A1# - B1 (H1)
G40-WX: G1 - G1#

FEATURES Handcrafted masterpiece made in Germany
Gentle frequency range
Printed logo on front and tuning info on the back

INCLUDES Gong handle, cover and gloves

3 INDIAN PREMIUM WIND GONG

SIZE 22"
MATERIAL Special bronze alloy
FEATURES Handcrafted masterpiece made in India
Mainly low pitched sound
Sizzling overtones
Hand engraved mantra
INCLUDES Table Gong Stand (TMTGS-L)

4 SYMPHONIC TAM TAMS

SIZES SY-TT24: 24"; SY-TT28: 28";
SY-TT32: 32"; SY-TT36: 36"

MATERIAL Nickelsilver
TUNING SY-TT24: G2 - G2#
SY-TT28: E2 - F2
SY-TT32: C2# - D2
SY-TT36: A1# - B1 (H1)

FEATURES Handcrafted masterpiece made in Germany
Printed logo on front and tuning info on the back

INCLUDES Cover and gloves



5 OPERA GONG

SIZE 12"
MATERIAL Special bronze alloy
FEATURES Handcrafted masterpiece made in China
Descending pitch
Audible glissando effect with very short sustain
INCLUDES Beater

6 WHITE GONGS

SIZES **WG-12:** 12"; **WG-145:** 14.5"
MATERIAL Special bronze alloy
FEATURES Handcrafted masterpiece made in China
Powerful and splashy clear sound
Flat profile with bended rim
INCLUDES Beater

7 TIGER GONG

SIZE **TG-125:** 12.5"; **TG-13:** 13"; **TG-14:** 14"
MATERIAL Special bronze alloy
FEATURES Handcrafted masterpiece made in China
Splashy sound
Pronounced bent-out shape
INCLUDES Beater

8 CHAU TAM TAMS

SIZES **CH-TT20:** 20"; **CH-TT22:** 22";
CH-TT24: 24"; **CH-TT26:** 26";
CH-TT28: 28"; **CH-TT30:** 30";
CH-TT32: 32"; **CH-TT34:** 34";
CH-TT36: 36"; **CH-TT38:** 38";
CH-TT40: 40"; **CH-TT44:** 44";
CH-TT48: 48"
MATERIAL Special bronze alloy
FEATURES Handcrafted masterpiece made in China
Printed logo and size info on the front
INCLUDES Beater and cover

9 WIND GONGS

SIZES **WG-TT12:** 12"; **WG-TT16:** 16";
WG-TT18: 18"; **WG-TT20:** 20";
WG-TT22: 22"; **WG-TT24:** 24";
WG-TT26: 26"; **WG-TT28:** 28";
WG-TT30: 30"; **WG-TT32:** 32";
WG-TT36: 36"; **WG-TT40:** 40";
WG-TT44: 44"; **WG-TT48:** 48"
MATERIAL Special bronze alloy
FEATURES Handcrafted masterpiece made in China
Mainly low pitched sound
Sizzling overtones
Printed logo and size info on the front
INCLUDES Beater and cover

PLANETARY TUNED GONGS & FLOWER OF LIFE

1 BASED ON THE CALCULATIONS OF HANS COUSTO (THE COSMIC OCTAVE)



Sidereal Moon,
24" / 60 cm
G24-M-SI

Venus,
24" / 60 cm
G24-V

Neptune,
24" / 60 cm
G24-N

Synodic Moon,
24" / 60 cm
G24-M-SY

Uranus,
24" / 60 cm
G24-U

Sidereal Day,
28" / 70 cm
G28-E-SI

Jupiter,
28" / 70 cm
G28-J

Sedna,
28" / 70 cm
G28-SE



Chiron,
28" / 70 cm
G28-CH

Platonic Year,
28" / 70 cm
G28-E-PL

Saturn,
32" / 80 cm
G32-SA

Mars,
32" / 80 cm
G32-MA

Mercury,
32" / 80 cm
G32-ME

Earth Year/Om,
36" / 90 cm
G36-E

Sun,
36" / 90 cm
G36-S

FLOWER OF LIFE TUNING FORK (SEE PAGE 14)

2

FLOWER OF LIFE ENERGY CHIME (SEE PAGE 24)



Tuning Fork
TF-FOL

24" / 60 cm
G24-FOL

36" / 90 cm
G36-FOL

Energy Chime
EC-FOL

1 PLANETARY TUNED GONGS

SIZES **G24:** 24"; **G28:** 28";
G32: 32"; **G36:** 36"

MATERIAL Nickelsilver

TUNING **CH:** Chiron, 172.86 Hz / F2
(A4/a' 440 Hz » 435.58 Hz)
E: Earth Year/Om, 136.10 Hz / C2#
(A4/a' 440 Hz » 432.09 Hz)
E-PL: Platonic Year, 172.06 Hz / F2
(A4/a' 440 Hz » 433.56 Hz)
E-SI: Sidereal Day, 194.71 Hz / G2
(A4/a' 440 Hz » 437.11 Hz)
J: Jupiter, 183.58 Hz / F2#
(A4/a' 440 Hz » 436.63 Hz)
M-SI: Sidereal Moon, 227.43 Hz / A2#
(A4/a' 440 Hz » 429.33 Hz)
M-SY: Synodic Moon, 210.42 Hz / G2#
(A4/a' 440 Hz » 445.86 Hz)
MA: Mars, 144.72 Hz / D2
(A4/a' 440 Hz » 433.67 Hz)

ME: Mercury, 141.27 Hz / C2#
(A4/a' 440 Hz » 448.50 Hz)
N: Neptune, 211.44 Hz / G2#
(A4/a' 440 Hz » 448.03 Hz)
S: Sun, 126.22 Hz / B1 (H1)
(A4/a' 440 Hz » 449.80 Hz)
SA: Saturn, 147.85 Hz / D2
(A4/a' 440 Hz » 443.05 Hz)
SE: Sedna, 181.60 Hz / F2#
(A4/a' 440 Hz » 431.92 Hz)
U: Uranus, 207.36 Hz / G2#
(A4/a' 440 Hz » 439.38 Hz)
V: Venus, 221.23 Hz / A2
(A4/a' 440 Hz » 442.46 Hz)

FEATURES Handcrafted masterpiece made in Germany
Exact fine tuning through hand-hammering
Printed alchemical symbols for each planet
on front and tuning info on the back

INCLUDES Cover and gloves

2 FLOWER OF LIFE GONGS

SIZES **G24-FOL:** 24"; **G36-FOL:** 36"

MATERIAL Nickelsilver

TUNING **G24-FOL:** 128 Hz / C3
(A4/a' 440 Hz » 430.54 Hz)
G36-FOL: 64 Hz / C2
(A4/a' 440 Hz » 430.54 Hz)

FEATURES Handcrafted masterpiece made in Germany
Exact fine tuning through hand-hammering
Printed logo on front and tuning info on
the back

INCLUDES Cover and gloves

GONG STANDS



TMGS



TMGS-2



TMGS-2-G



TMGS-DS



Set
TMGS-W



TMGS-3



TMGS-3-G

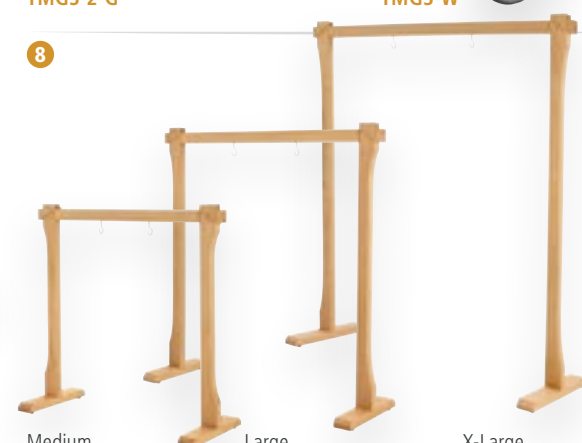

Medium
TMWGS-M

Large
TMWGS-L

X-Large
TMWGS-XL



TMGWM

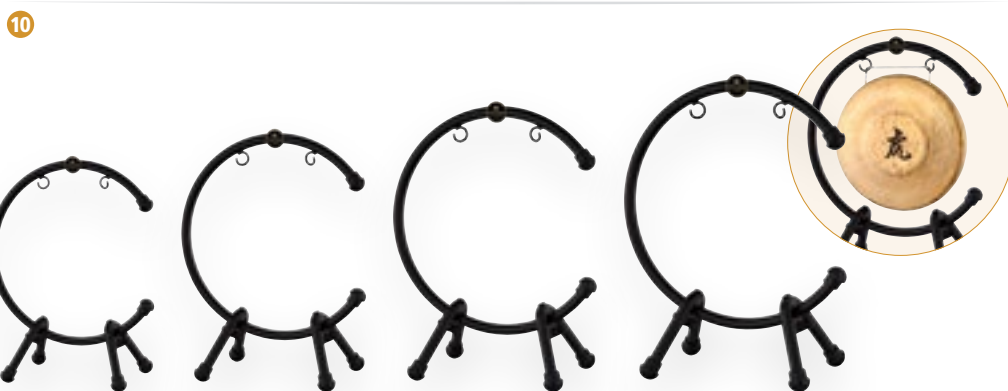

Small
TMTGS-S

Medium
TMTGS-M

Large
TMTGS-L

X-Large
TMTGS-XL

1 GONG STAND

SIZE Up to 32" gong size
MATERIAL Black powder coated steel
FEATURE Height adjustable with locking system
INCLUDES Allen wrench

2 PRO GONG STAND

SIZE Up to 40" gong size
MATERIAL Black powder coated steel
FEATURES Especially for bigger sized gongs; Height adjustable with locking system
INCLUDES Allen wrench

3 GONG HOLDER

SIZE Upper gong size up to 32"
Lower gong size up to 40"
MATERIAL Black powder coated steel
FEATURE For Pro Gong Stand only
INCLUDES Allen wrench

4 GONG DAMPENING SYSTEM

MATERIALS Black powder coated steel; Foam
FEATURES Height adjustable to mute all gong sizes

5 WHEELS FOR GONG STANDS

FEATURES Set of four; For ease of mobility

6 FRAMED GONG STAND

SIZE Up to 40" gong size
MATERIAL Black powder coated steel
FEATURES Especially for bigger sized gongs; Height adjustable with locking system
INCLUDES Allen wrench

7 FRAMED GONG HOLDER

SIZE Upper gong size up to 38"
Lower gong size up to 40"
MATERIAL Black powder coated steel
FEATURE For Framed Gong Stand only
INCLUDES Allen wrench

8 WOOD GONG STANDS

SIZES **M**: Medium; Up to 34" gong size
L: Large; Up to 40" gong size
XL: X-Large; Up to 50" gong size
MATERIAL Beech wood

9 GONG WALL MOUNT

MATERIAL Black powder coated steel
FEATURE Space-saving
INCLUDES Screws and dowels

10 TABLE GONG STANDS

SIZES **S**: Small; Up to 13" gong size
M: Medium; Up to 15" gong size
L: Large; Up to 22" gong size
XL: X-Large; Up to 26" gong size
MATERIAL Black powder coated steel
FEATURE Gong can be played in comfortable position on the floor or table
INCLUDES Hex key

GONG MALLETS & BEATERS

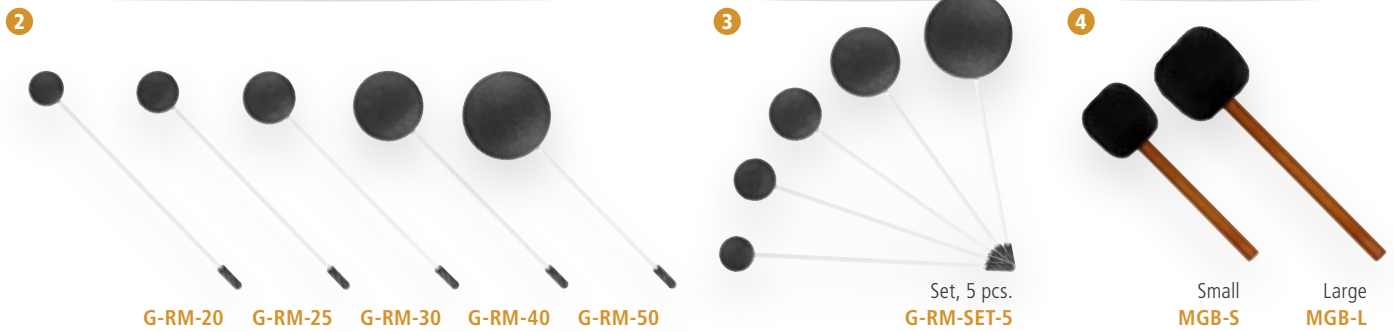

1 GONG MALLETS

DIMENSIONS **MGM-S:** Small (11.81" x 2.76" x 2.76"); 138 g; For gongs from 20" to 80"
MGM-M: Medium (13.58" x 3.15" x 3.15"); 222 g; For gongs from 22" to 80"
MGM-L: Large (15.55" x 3.94" x 3.94"); 374 g; For gongs from 24" to 80"

MATERIALS Beech wood handle; Fleece

FEATURE May be used also as a pair

COLOURS **C:** Chai
L: Lavender
PG: Pure Green
R: Rose
SP: Sea Petrol
ST: Sweet Tangerine

2 GONG RESONANT MALLET

SIZES **G-RM-20:** 0.8"
G-RM-25: 1.0"
G-RM-30: 1.2"
G-RM-40: 1.6"
G-RM-50: 2.0"

MATERIAL Specially treated rubber ball

FEATURES Produces a gentle effect of the high and deepest low tones
 Explore therapeutic and atmospheric sounds with these mallets

3 GONG RESONANT MALLET SET

CONTAINS G-RM-20, G-RM-25, G-RM-30, G-RM-40, G-RM-50

4 GONG BEATERS

DIMENSIONS **MGB-S:** Small; +/- 220 g; For gongs up to 28"
MGB-L: Large; +/- 350 g; For gongs up to 40"

MATERIAL Sapele wood handle

FEATURES To create a wide range of dynamics
 Heat-branded logo

5 TAM TAM BEATERS

DIMENSIONS **MTTB-24:** +/- 250 g; For 24" tam tams
MTTB-28: +/- 500 g; For 28" tam tams
MTTB-32: +/- 600 g; For 32" tam tams
MTTB-36: +/- 700 g; For 36" tam tams
MTTB-40: +/- 800 g; For 40" tam tams

MATERIAL Beech wood handle

6 MALLET BAG

MATERIAL Heavy-duty padded nylon

FEATURE Carrying grip

GONG ACCESSORIES

1

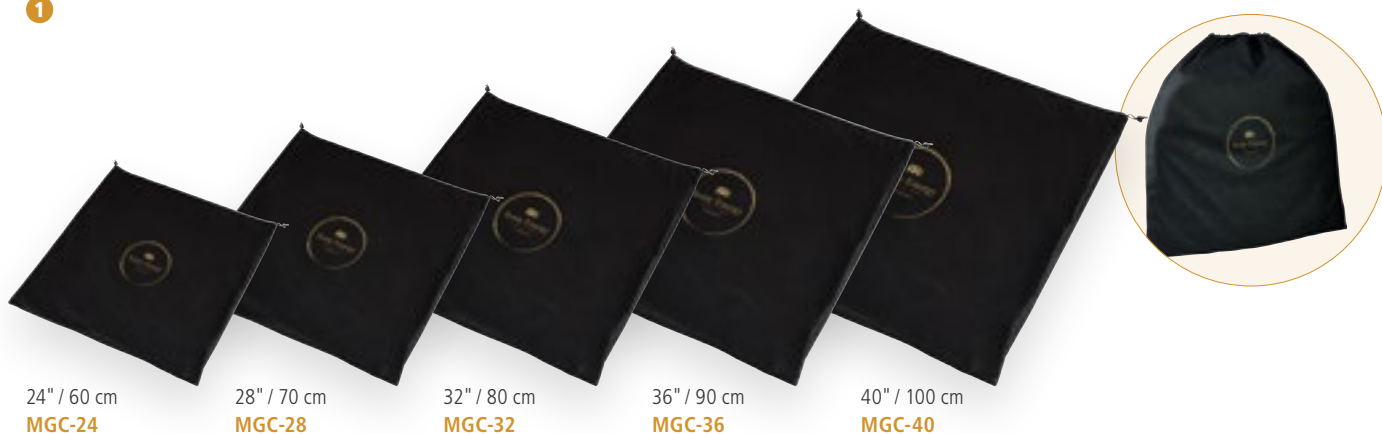

24" / 60 cm
MGC-24

28" / 70 cm
MGC-28

32" / 80 cm
MGC-32

36" / 90 cm
MGC-36

40" / 100 cm
MGC-40

2



24" / 60 cm
MGB-24

28" / 70 cm
MGB-28

32" / 80 cm
MGB-32

36" / 90 cm
MGB-36

38" / 95 cm
MGB-38

40" / 100 cm
MGB-40

3

NEW



Beige
MMC

4



G-HANDLE

6



MGP

7



MCKK-MCCL

5



GC-2428

GC-32

GC-3640

1 GONG COVERS

SIZES **MGC-24:** For 24" gongs
MGC-28: For 28" gongs
MGC-32: For 32" gongs
MGC-36: For 36" gongs
MGC-40: For 40" gongs

MATERIALS Inner material velvet
Outer material polyester

FEATURE Protects against dust and fingerprints

2 GONG BAGS

SIZES **MGB-24:** For 24" gongs
MGB-28: For 28" gongs
MGB-32: For 32" gongs
MGB-36: For 36" gongs
MGB-38: For 38" gongs
MGB-40: For 40" gongs

MATERIALS Inner material velvet
Outer material durable nylon

FEATURE Protects during transportation

3 MEDITATION CUSHION

SIZE 12.2" diameter, 7.87" height
MATERIAL Cotton; Buckwheat bowl filling
FEATURES Ideal for use in yoga studios, therapy centers, for your meditation at home or as a flexible seat; Washable at 30 degrees

4 GONG HANDLE

MATERIAL Beech wood
FEATURE For comfortable holding

5 GONG CORDS

SIZES **GC-2428:** For gongs from 24" to 28"
GC-32: For 32" gongs
GC-3640: For gongs from 36" to 40"

6 GONG POLISH

SIZE 250 ml
FEATURE For polishing the surface of a gong

7 CARE KIT

FEATURES For cleaning and protecting the surface of a gong
Not affecting the sound
Easy-to-use spray
INCLUDES Cymbal handling gloves

PLANETARY TUNED ENERGY CHIMES

1 BASED ON THE CALCULATIONS OF HANS COUSTO (THE COSMIC OCTAVE)



2

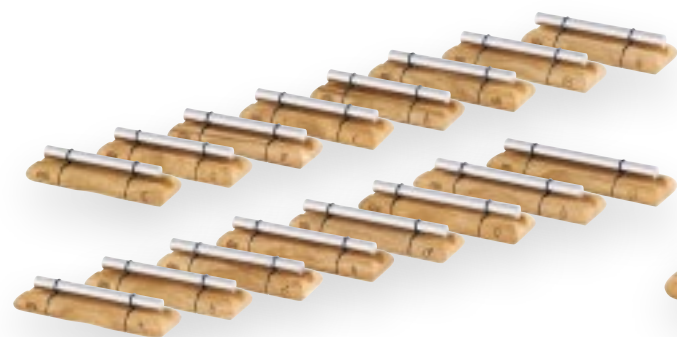

Set, 16 pcs.
EC-SET-16

3



Set, 7 pcs.
EC-SET-CHA-7

4



Flower of Life
EC-FOL

5



ECC-8

1 PLANETARY TUNED ENERGY CHIMES

MATERIAL Silver anodized aluminum alloy
TUNING **CH:** Chiron, 2765.76 Hz / F7
E: Earth Year/Om, 2177.60 Hz / C7#
E-PL: Platonic Year, 2752.96 Hz / F7
E-SI: Sidereal Day, 3115.36 Hz / G7
E-SY: Synodic Day, 3106.88 Hz / G7
J: Jupiter, 2937.28 Hz / F7#
M-SI: Sidereal Moon, 3638.88 Hz / A7#
M-SY: Synodic Moon, 3366.72 Hz / G7#
MA: Mars, 2315.52 Hz / D7
ME: Mercury, 2260.32 Hz / C7#
N: Neptune, 3383.04 Hz / G7#
S: Sun, 2019.52 Hz / B6
SA: Saturn, 2365.60 Hz / D7
SE: Sedna, 2905.60 Hz / F7#
U: Uranus, 3317.76 Hz / G7#
V: Venus, 3539.68 Hz / A7

FEATURES Handcrafted masterpiece made in Thailand
 Exact fine tuning
 Heat-branded logo and tuning info
INCLUDES Wooden beater

2 ENERGY CHIMES COMPLETE SET-UP

CONTAINS EC-CH, EC-E, EC-E-PL, EC-E-SI, EC-E-SY, EC-J, EC-M-SI, EC-M-SY, EC-MA, EC-ME, EC-N, EC-S, EC-SA, EC-SE, EC-U, EC-V
INCLUDES 16 x wooden beater

3 ENERGY CHIMES CHAKRA SET

CONTAINS 1. Root Chakra: EC-E-SY (Synodic Day)
 2. Sacral Chakra: EC-M-SY (Synodic Moon)
 3. Navel Chakra: EC-S (Sun)
 4. Heart Chakra: EC-E (Earth)
 5. Throat Chakra: EC-ME (Mercury)
 6. Brow Chakra: EC-V (Venus)
 7. Crown Chakra: EC-E-PL (Platonic Year)
INCLUDES 7 x wooden beater

4 FLOWER OF LIFE ENERGY CHIME

MATERIAL Silver anodized aluminum alloy
TUNING 2048 Hz / C7
FEATURES Handcrafted masterpiece made in Thailand
 Exact fine tuning
 Heat-branded logo and tuning info
INCLUDES Wooden beater

5 ENERGY CHIME CASE

SIZE For 8 energy chimes
MATERIALS Inner material foam
 Outer material leatherette
FEATURES For safe and easy transportation

METAL EFFECTS

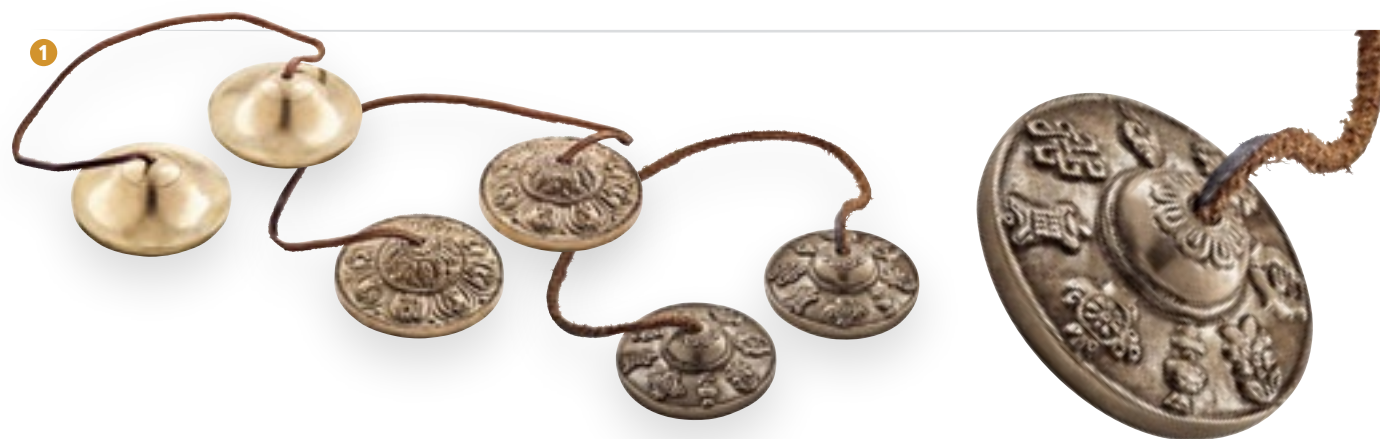

TINGSHA

TINGSHA-OR

TINGSHA-8

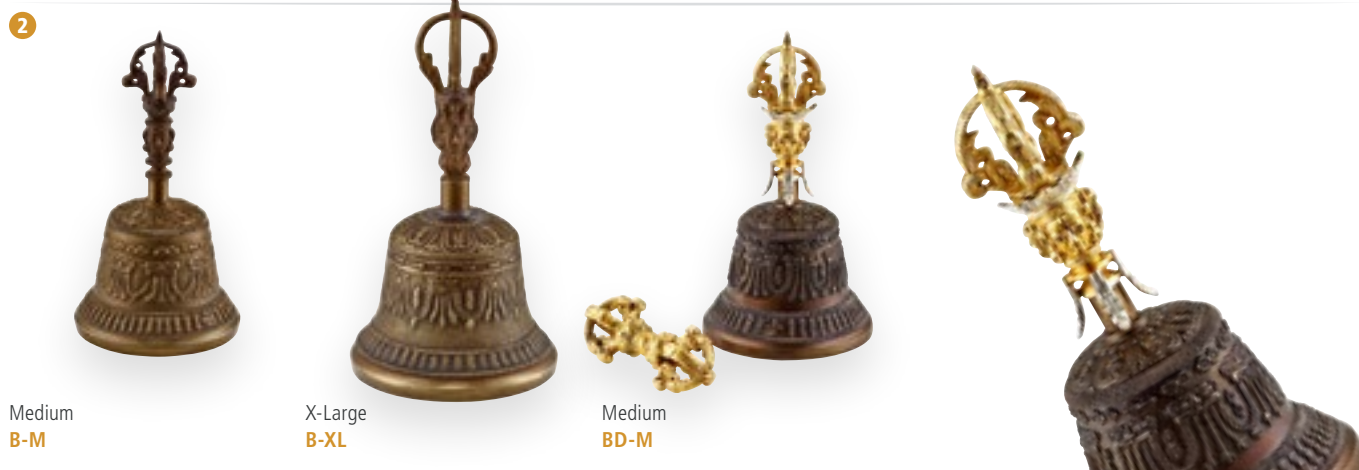

Medium
B-M

X-Large
B-XL

Medium
BD-M



27 bars
CH27WB



MARIMBULA

1 TINGSHAS

SIZES **TINGSHA:** 3.15"
TINGSHA-OR: 3.15"
TINGSHA-8: 2.68"

MATERIAL Special cast alloy

FEATURES Handcrafted masterpiece made in India
Used for meditation

INCLUDES Cotton bag

SYMBOLS **OR:** Ornamental
8: 8 Luck Symbols (Ashtamangala)

2 BELLS

DIMENSIONS **B-M:** Medium (3.5"); 355 g
B-XL: X-Large (4.3"); 700 g
BD-M: Medium (3.5"); 405 g

MATERIAL Special cast alloy

FEATURES Handcrafted masterpiece made in India
Used for meditation

INCLUDES **BD-M:** Dorje

3 CHIMES, 27 BARS

SIZE 27 bars, single row

MATERIALS Jamjuree wood
Gold anodized aluminum alloy

FEATURE Full sound with wide tonal spectrum

COLOUR **WB:** Walnut Brown

4 MARIMBULA

SIZE 23.5" W x 15.75" H x 8.25" D

MATERIALS Siam Oak (*Hevea brasiliensis* Muell.-Arg.)
Steel tongues

TUNING f, c, G, D, F, A, d, g

FEATURE Solid construction
Heavy-duty rubber feet for a solid base

COLOUR Brown

FINISH Matte

MEINL SENSORY & HARMONIC ART HANDPANS

1 NEW MEINL SENSORY HANDPANS

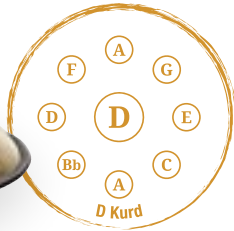

D Kurd, 9 tones
HPSTL90



D Amara, 9 tones
HPSTL91

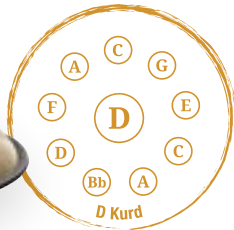

D Kurd, 10 tones
HPSTL100

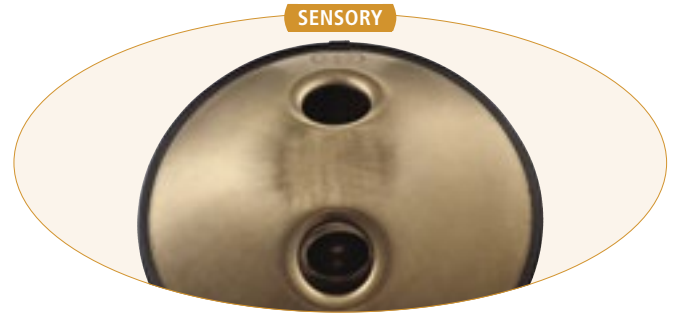

2 MEINL HARMONIC ART HANDPANS



Natural D, Black
HD1



Natural D, White Jade
HD1-WJ



Natural D, Bronzite
HD1-B



Equinox E, Black
HD2



Equinox E, White Jade
HD2-WJ



Equinox E, Bronzite
HD2-B

1 MEINL SENSORY HANDPANS

- SIZE** 22" diameter, 9" height
- MATERIAL** Stainless steel
- TUNING** 440 Hz
- HPSTL90:** D/ A, Bb, C, D, E, F, G, A (9 tones)
- HPSTL91:** D/ A, C, D, E, F, G, A, C (9 tones)
- HPSTL100:** D/ A, Bb, C, D, E, F, G, A, C (10 tones)
- FEATURES** Handcrafted masterpiece
Clear and pure soft sound with long sustain
Resistant stainless steel material
Harmonic and balanced tones
Engraved logo and tuning
- INCLUDES** Protection bag, velvet bag and gloves
- COLOUR** Vintage Gold





Raga Desya Todi D#, Black
HD3



Raga Desya Todi D#, White Jade
HD3-WJ



Raga Desya Todi D#, Bronzite
HD3-B



Natural Prime F, Black
HD1-F



Akebono F, Black
HD4



Akebono F, White Jade
HD4-WJ



Akebono F, Bronzite
HD4-B



432 Hz Equinox E, Black
HD2-432



Integral D, Black
HD5



Integral D, White Jade
HD5-WJ



Integral D, Bronzite
HD5-B



Expert D#, Black
HD6-EXPERT



Dominant D, Black
HD6



Dominant D, White Jade
HD6-WJ



Dominant D, Bronzite
HD6-B



Free Integral C#, Black
HD7

2 MEINL HARMONIC ART HANDPANS

SIZE 21.5" diameter, 10" height

MATERIAL High quality steel

TUNING 8 tones

HD1: Natural D/ A, A#, C, D, F, G, A

HD1-F: Natural Prime F/ A, A#, C, D, F, G, A

HD2: Equinox E/ G, B, C, D, E, F#, G

HD2-432: 432 Hz Equinox E/ G, B, C, D, E, F#, G

HD3: Raga Desya Todi D#/ G, A#, C, D, D#, F, G

HD4: Akebono F/ A#, C, C#, D#, F, F#, A#

HD5: Integral D/ A, A#, C, D, E, F, A

HD6: Dominant D/ A, C, D, E, F, G, A

HD6-EXPERT: Expert D#/ G#, A#, B, C#, D#, F#, G#

HD7: Free Integral C#/ G#, A, B, C#, D#, E, G#

FEATURES

Handcrafted masterpiece

Clear and pure soft sound with long sustain

Harmonic and balanced connection

B, WJ: Sustainable, maintenance-free coating for protection

INCLUDES

Protection cover, bag and gloves

COLOURS

Black

B: Bronzite

WJ: White Jade

HANDPAN ACCESSORIES

1



EV

2



HDB

3

NEW



SEPU

4



HPS-S

4



HPS

5

NEW



HPC

Set, 2 pcs.
HPCS

7



HPR

8



HPWS

9

NEW



HPWS2

1 HANDPAN HARDCASE

SIZE 23.5" diameter, 12" height
MATERIALS Special ABS plastic and EVA material
FEATURES Ergonomic handle; 100 % waterproof; Removable shoulders straps
INCLUDES Pocket Bag; Carabiner

2 HANDPAN BAG

SIZE 25" diameter, 11.5" height
MATERIALS Heavy-duty nylon; Synthetic fur
FEATURES Additional layer of synthetic fur for maximum protection; Backpack straps; Carrying grip

3 MAGNETIC PICKUP

MATERIAL Plastic
FEATURES Magnetic; Piezo pickup; Integrated volume regulator; 6.3 mm input jack; 2.5 m long cable

4 HANDPAN STANDS

SIZES **HPS-S:** Height adjustable (22"-27")
HPS: Height adjustable (28"-39")
MATERIAL Black powder coated steel
FEATURE For Handpans and Steel Tongue Drums

5 HANDPAN CARE

SIZE 150 ml
PRODUCTS **HPC:** Handpan Cleaner
HPP: Handpan Protectant
HPCS: Handpan Care Set
CONTAINS **HPCS:** 1 x HPP, 1 x HPC
FEATURES Cleaning and sealing the handpan; Designed for any unlacquered handpan; Corrosion protection; Made in Germany
HPC: Basis of jojoba oil
HPP: Mixture of jojoba oil and wax
INCLUDES **HPCS:** Two microfiber cloths

6 HARMONIC ART HANDPAN CARE WAX

SIZE 36 ml
FEATURE Designed for any lacquered handpan; Prevents unwanted development of rust

7 HANDPAN REST

MATERIAL Baltic Birch (*Betula pendula*)
FEATURE For easy storage

8 WOOD HANDPAN STAND

MATERIAL Baltic Birch (*Betula pendula*)
FEATURE Fits for handpans with ~21.5" diameter

9 INCLINED WOOD HANDPAN STAND

MATERIAL Baltic Birch (*Betula pendula*)
FEATURE Fits for handpans with ~22" diameter

STEEL TONGUE DRUMS

1 NEW



C Major, Black
MSTD1BK



A Major, Navy Blue
MSTD2NB



B Major, Gold
MSTD3G



2



A Minor, Black
STD1BK



A Akebono, Black
STD2BK



G Major, Black
STD3BK



A Minor, Vintage Brown
STD1VB



A Akebono, Vintage Brown
STD2VB



G Major, Vintage Brown
STD3VB

3



STDB



1 MINI STEEL TONGUE DRUMS

SIZE 5.9" diameter, 2.55" height
MATERIAL Coated steel
TUNING **MSTD1BK:** C Major
C5, D5, E5, G5, A5, C6
MSTD2NB: A Major
A4, B4, C#5, E5, F#5, A5
MSTD3G: B Major
B4, C#5, D#5, F#5, G#5, B5
FEATURES Miniature size Steel Tongue Drum
Great for yoga studios, sound therapy,
classrooms or your coffee table
Pre-tuned scale
Soothing and tranquil tone
INCLUDES Bag
Rubber Mallet Pair
COLOURS **BK:** Black
G: Gold
NB: Navy Blue

2 STEEL TONGUE DRUMS

SIZE 12" diameter, 6.5" height
MATERIAL Black powder coated steel
TUNING **STD1:** A Minor
A3/ C4, D4, E4, G4, A4, C5, D5
STD2: A Akebono
A3/ B3, C4, E4, F4, A4, B4, C5
STD3: G Major
G3/ A3, B3, D4, E4, G4, A4, B4
FEATURE Rich, full-sound
INCLUDES Bag
Steel Tongue Drum Mallet pair (STDB)
COLOURS **BK:** Black
VB: Vintage Brown

3 STEEL TONGUE DRUM MALLETS

SIZE 11.25"
FEATURES Designed to elicit full-bodied, rich tones
Textured grips provide firm control

SOUND EFFECTS



1 NEW
SPRL

Large
SPRL



Small
SPRS



2 NEW
SPH

SPH



3 NEW
SPCH

SPCH



4 NEW
SPB

SPB



5 NEW
SKRL

Large
SKRL



Small
SKRS

SKRS



6 NEW
SKH

SKH



7 NEW
SKCH

SKCH



8 NEW
SKB

SKB



9 NEW
SBRS

Small
SBRS



10 NEW
SPGRS

Small
SPGRS

1 PALA SHAKERS

SIZES SPRL: Large (13.7")
SPRS: Small (11.0")
MATERIAL Pala seed nutshells
FEATURES Comfortable wrist strap
Pleasant, smooth sound

2 PALA ROD SHAKER

SIZE 9.0"
MATERIAL Pala seed nutshells
FEATURES Comfortable rod shaker
Pleasant, smooth sound

3 PALA CHIMES

SIZE 16.7" x 15.7"
MATERIALS Pala seed nutshells
Mahogany wood
FEATURE Pleasant, smooth sound

4 PALA BRACELET

SIZE 3.7" x 2.4"
MATERIAL Pala seed nutshells
FEATURES Bracelet shaker
Pleasant, smooth sound

5 KENARI SHAKERS

SIZES SKRL: Large (12.6")
SKRS: Small (9.0")
MATERIAL Kenari seed nutshells
FEATURES Comfortable wrist strap
Powerful, crisp sound

6 KENARI ROD SHAKER

SIZE 9.0"
MATERIAL Kenari seed nutshells
FEATURES Comfortable rod shaker
Powerful, crisp sound

7 KENARI CHIMES

SIZE 16.7" x 14.6"
MATERIALS Kenari seed nutshells
Mahogany wood
FEATURE Powerful, crisp sound

8 KENARI BRACELET

SIZE 3.7" x 2.4"
MATERIAL Kenari seed nutshells
FEATURES Bracelet shaker
Powerful, crisp sound

9 BENDO SHAKER

SIZE 8.3"
MATERIAL Bendo seed nutshells
FEATURES Comfortable wrist strap
Clear, crisp sound



Small
TD-S

Large
TD-L

15 NEW



Note C, 19.7"
DDPROFSC



Note D, 19.7"
DDPROFSD



12 NEW

23.0"
RS1S

31.5"
RS1M

39.8"
RS1L

16 NEW



Note C, 25.3"
DDPROFZC



Note D, 25.3"
DDPROFZD



13 NEW

47.2"
DD1BK

14 NEW

Note E, 61.2"
DDPROFPE

Note D, 73.2"
DDPROFNTD

10 PANGI SHAKER

SIZE 8.3"
MATERIAL Pangi seed nutshells
FEATURES Comfortable wrist strap
Powerful, deep sound

11 THUNDER DRUMS

SIZES TD-S: Small (7.48")
TD-L: Large (9.84")
MATERIAL Synthetic body
FEATURES Durable construction
Authentic thunder sounds

12 BAMBOO RAINSTICKS

SIZES RS1S: Small (23.0")
RS1M: Medium (31.5")
RS1L: Large (39.8")
MATERIAL Bamboo
FEATURES Lightweight; Dot-painted
COLOUR Black

13 BAMBOO DIDGERIDOO

SIZE 47.2"
MATERIAL Bamboo
FEATURE Dot-painted
COLOUR Black

14 SLICED PRO DIDGERIDOOS

SIZES DDPROFNTD: 73.2"
DDPROFPE: 61.2"
MATERIAL Mahogany
TUNING DDPROFNTD: D
DDPROFPE: E
FEATURES Screw mechanism to separate into
two pieces
DDPROFPE: Dot-painted
INCLUDES Bag
COLOURS DDPROFNTD: Natural
DDPROFPE: Black

15 S-SHAPED PRO DIDGERIDOOS

SIZE 11.0" W x 19.7" H x 2.5" D
MATERIAL Mahogany
TUNING DDPROFSC: C
DDPROFSD: D
FEATURE S-shape offers full tone and volume
at a compact size
COLOUR Natural

16 Z-SHAPED PRO DIDGERIDOOS

SIZE 6.3" W x 25.3" H x 2.2" D
MATERIAL Mahogany
TUNING DDPROFZC: C
DDPROFZD: D
FEATURE Z-shape offers full tone and volume
at a compact size
COLOUR Natural

FRAME DRUMS

1



Endless Knot, 15"
HOD15-EK



Flower of Life, 15"
HOD15-FOL



Triskele, 15"
HOD15-TR



Venus Flower, 15"
HOD15-VF

2



Endless Knot, 16"
HD16WB-EK



Flower of Life, 16"
HD16WB-FOL



Triskele, 16"
HD16WB-TR



Venus Flower, 16"
HD16WB-VF

3 **NEW**



18"
HD18WB



20"
HD20WB



18"
HD18WB-WH

1 NATIVE AMERICAN-STYLE HOOP DRUMS

SIZE 15"
MATERIALS Hand selected buffalo head
Nylon lacing and grip
FEATURES Warm and powerful sound
Adjustable hand grip
INCLUDES Leather padded wooden beater
SYMBOLS **EK:** Endless Knot
FOL: Flower of Life
TR: Triskele
VF: Venus Flower

2 HAND DRUMS

SIZES **HD16:** 16"
HD18: 18"
HD20: 20"
MATERIALS Siam Oak (*Hevea brasiliensis* Muell.-Arg.)
Hand selected goat head
FEATURES Comfortable grip
Warm, rich and resonating tones
SYMBOLS **EK:** Endless Knot
FOL: Flower of Life
TR: Triskele
VF: Venus Flower
COLOUR **WB:** Walnut Brown

3 WOVEN SYNTHETIC HEAD HAND DRUM

SIZE 18"
MATERIALS Siam Oak (*Hevea brasiliensis* Muell.-Arg.)
Woven synthetic head
FEATURES Comfortable grip
Durable, synthetic head
Rich and resonating tones
COLOUR Walnut Brown



4 WAVE DRUMS

- SIZES** **WD16:** 16"
WD18: 18"
WD20: 20"
WD22: 22"
- MATERIALS** Siam Oak (*Hevea brasiliensis* Muell.-Arg.)
Hand selected goat head and synthetic head
- FEATURES** Sealable filling port allows you to control the amount of steel balls inside
Two different drum heads
Soothing sounds
- COLOUR** **WB:** Walnut Brown

MEINL ONLINE



facebook.com/**meinpercussionfanpage**

facebook.com/**meinlvivarhythm**

facebook.com/**ninopercussion**

facebook.com/**meinlsonicenergy**

instagram.com/**meinpercussion**

instagram.com/**meinlvivarhythm**

instagram.com/**ninopercussion**

instagram.com/**meinlsonicenergy**



youtube.com/**meinpercussion**

youtube.com/**meinlvivarhythm**

youtube.com/**ninopercussion**

youtube.com/**meinlsonicenergy**



twitter.com/**meinpercussion**

twitter.com/**meinlvivarhythm**

twitter.com/**ninopercussion**

twitter.com/**meinlsonic**



meinpercussion.com

meinlvivarhythm.com

ninopercussion.com

meinlsonicenergy.com



DISCLAIMER

All features are subject to change without notice. Not responsible for typographic errors. No part of this book may be reprinted, reproduced, or included in any online service in any form in whole or in part, without the prior permission of MEINL.

© 2021 Roland Meinl Musikinstrumente GmbH & Co. KG

ADVERTISING CONCEPT & DESIGN

ercas GmbH & Co. KG [ercasdieagentur.de]

CONTENT & DIRECTION

Hannes Auerochs

COPYWRITING

Ayrton Gauerke, Jim Busch, Hannes Auerochs

PHOTOGRAPHY

Christian Habermeier, Sebastian Jäger, Angelika Jakobs
[studio-waldeck.de]

Miroslav Šmikmátor [smikmatorphoto.com]

Tobias Winklmann, Quentin Brandt, Hannes Auerochs
Adobe Stock / Kitja

LITHOGRAPHY

Sven Mihm [mihm-werbung.de]

GLOBAL HEADQUARTERS

Roland Meinl Musikinstrumente GmbH & Co. KG

Musik-Meinl-Straße 1

91468 Gutenstetten

Germany

US HEADQUARTERS

MEINL USA L.C.

3427 Ambrose Avenue

Nashville, TN 37207

USA

INVENTORS OF SELECTED PRODUCTS

Bill Saragosa

Dany Moreno

Gilson Batista Da Silveira

José J. Cortijo

Juan Carlos Melian

Marcus Ralph De Mowbray

Mark Allen Johnson

Michael Buchner

Reiko Guthschmidt

Taku Hirano

Torsten Franz

REMO®, Fiberskyn®, Nuskyn® and Skyndeeep®
are registered trademarks of REMO® Inc.

Used by permission.

This catalogue has been printed on
climate neutral paper.

Printed in Germany M-CA151220

